

FEATURES

The HV series not only withstands high temperatures (200°C), but also offers high voltage (500-4000 VDC)

To be used in robust applications

- Down Hole
- Industrial
- Harsh Environments

NOTE:

Other tolerances, higher capacitance values, voltages, or special package configurations are available upon request.

CAPACITOR OUTLINE DRAWING

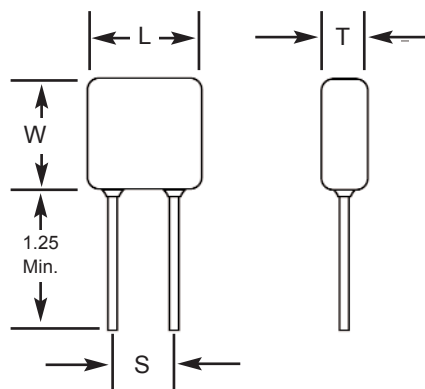

DIMENSIONS

Style	Sizes in Inches (mm) max.			Lead Spacing ±0.030 (S)
	Length (L)	Width (W)	Thickness (T)	
HV10	.250 (6.35)	.220 (5.59)	.150 (3.81)	.170 (4.32)
HV11	.320 (8.13)	.300 (7.62)	.250 (6.35)	.200 (5.08)
HV12	.420 (10.67)	.400 (10.16)	.250 (6.35)	.300 (7.62)
HV13	.520 (13.21)	.500 (12.70)	.300 (7.62)	.400 (10.16)
HV14	.620 (15.75)	.500 (12.70)	.300 (7.62)	.500 (12.70)
HV15	.720 (18.29)	.700 (17.78)	.300 (7.62)	.600 (15.24)
HV16	.820 (20.83)	.700 (17.78)	.350 (8.89)	.700 (17.78)

PART NUMBER AND ORDERING INFORMATION

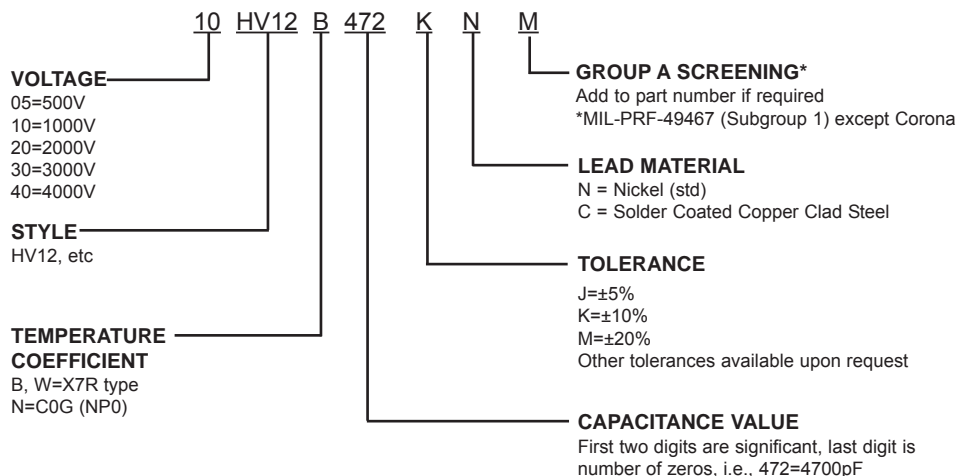

MARKING

(HV10, HV11)
472M
KEC
Date Code

(All other sizes)
HV12B472M
1kV
KEC
Date Code

High Temperature (+200°C), High Voltage Radial Ceramic Capacitors HV Series

COG DIELECTRIC

STYLE		HV10			HV11			HV12			HV13			HV14				HV15				HV16								
Cap	L MAX	.250 (6.35)			.320 (8.13)			.420 (10.67)			.520 (13.21)			.620 (15.75)				.720 (18.29)				.820 (20.83)								
	W MAX	.220 (5.59)			.300 (7.62)			.400 (10.16)			.500 (12.70)			.500 (12.70)				.700 (17.78)				.700 (17.78)								
	T MAX	.150 (3.81)			.250 (6.35)			.250 (6.35)			.300 (7.62)			.300 (7.62)				.300 (7.62)				.350 (8.89)								
	S ± .030	.170 (4.32)			.200 (5.08)			.300 (7.62)			.400 (10.16)			.500 (12.70)				.600 (15.24)				.700 (17.78)								
	Lead Dia. +0.004/-0.002	.025 (.635)			.025 (.635)			.025 (.635)			.025 (.635)			.025 (.635)				.025 (.635)				.025 (.635)								
	Cap Code	WVDC			WVDC			WVDC			WVDC			WVDC				WVDC				WVDC								
	500	1k	2k	500	1k	2k	3k	500	1k	2k	3k	500	1k	2k	3k	500	1k	2k	3k	4k	500	1k	2k	3k	4k	500	1k	2k	3k	4k
12pF	120																													
15	150																													
18	180																													
22	220																													
27	270																													
33	330																													
39	390																													
47	470																													
56	560																													
68	680																													
82	820																													
100	101																													
120	121																													
150	151																													
180	181																													
220	221																													
270	271																													
330	331																													
390	391																													
470	471																													
560	561																													
680	681																													
820	821																													
1000	102																													
1200	122																													
1500	152																													
1800	182																													
2200	222																													
2700	272																													
3300	332																													
3900	392																													
4700	472																													
5600	562																													
6800	682																													
8200	822																													
0.01uF	103																													
0.012	123																													
0.015	153																													

X7R DIELECTRIC

STYLE		HV10			HV11			HV12			HV13				HV14				HV15				HV16					
Cap	L MAX	.250 (6.35)			.320 (8.13)			.420 (10.67)			.520 (13.21)				.620 (15.75)				.720 (18.29)				.820 (20.83)					
	W MAX	.220 (5.59)			.300 (7.62)			.400 (10.16)			.500 (12.70)				.500 (12.70)				.700 (17.78)				.700 (17.78)					
	T MAX	.150 (3.81)			.250 (6.35)			.250 (6.35)			.300 (7.62)				.300 (7.62)				.300 (7.62)				.350 (8.89)					
	S± .030	.170 (4.32)			.200 (5.08)			.300 (7.62)			.400 (10.16)				.500 (12.70)				.600 (15.24)				.700 (17.78)					
	Lead Dia. +0.004/-0.002	.025 (.635)			.025 (.635)			.025 (.635)			.025 (.635)				.025 (.635)				.025 (.635)				.025 (.635)					
	Cap Code	WVDC			WVDC			WVDC			WVDC				WVDC				WVDC				WVDC					
	500	1k	2k	500	1k	2k	500	1k	2k	500	1k	2k	3k	500	1k	2k	3k	4k	500	1k	2k	3k	4k	500	1k	2k	3k	4k
270pF	271																											
330	331																											
390	391																											
470	471																											
560	561																											
680	681																											
820	821																											
1000	102																											
1200	122																											
1500	152																											
1800	182																											
2200	222																											
2700	272																											
3300	332																											
3900	392																											
4700	472																											
5600	562																											
6800	682																											
8200	822																											
0.01uF	103																											
0.012	123																											
0.015	153																											
0.018	183																											
0.022	223																											
0.027	273																											
0.033	333																											
0.039	393																											
0.047	473																											
0.056	563																											
0.068	683																											
0.082	823																											
0.10	104																											
0.12	124																											
0.15	154																											
0.18	184																											
0.22	224																											
0.27	274																											
0.33	334																											
0.39	394																											
0.47	474																											

Данный компонент на территории Российской Федерации

Вы можете приобрести в компании MosChip.

Для оперативного оформления запроса Вам необходимо перейти по данной ссылке:

<http://moschip.ru/get-element>

Вы можете разместить у нас заказ для любого Вашего проекта, будь то серийное производство или разработка единичного прибора.

В нашем ассортименте представлены ведущие мировые производители активных и пассивных электронных компонентов.

Нашей специализацией является поставка электронной компонентной базы двойного назначения, продукции таких производителей как XILINX, Intel (ex.ALTERA), Vicor, Microchip, Texas Instruments, Analog Devices, Mini-Circuits, Amphenol, Glenair.

Сотрудничество с глобальными дистрибьюторами электронных компонентов, предоставляет возможность заказывать и получать с международных складов практически любой перечень компонентов в оптимальные для Вас сроки.

На всех этапах разработки и производства наши партнеры могут получить квалифицированную поддержку опытных инженеров.

Система менеджмента качества компании отвечает требованиям в соответствии с ГОСТ Р ИСО 9001, ГОСТ РВ 0015-002 и ЭС РД 009

Офис по работе с юридическими лицами:

105318, г.Москва, ул.Щербаковская д.3, офис 1107, 1118, ДЦ «Щербаковский»

Телефон: +7 495 668-12-70 (многоканальный)

Факс: +7 495 668-12-70 (доб.304)

E-mail: info@moschip.ru

Skype отдела продаж:

moschip.ru

moschip.ru_4

moschip.ru_6

moschip.ru_9