

DATA SHEET

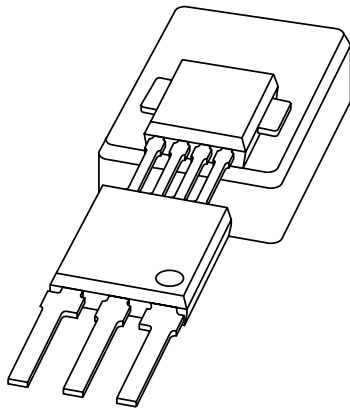

KMI16/1

Integrated rotational speed sensor

Product specification
Supersedes data of 1998 May 15

2000 Sep 05

Integrated rotational speed sensor

KMI16/1

DESCRIPTION

The KMI16/1 sensor detects rotational speed of ferrous gear wheels and reference marks.

The sensor consists of a magnetoresistive sensor element, a signal conditioning integrated circuit in bipolar technology and a ferrite magnet.

The frequency of the digital current output signal is proportional to the rotational speed of the target wheel.

The open collector (OC) output allows for a high degree of flexibility in the design of subsequent conditioning electronics.

CAUTION
Do not press two or more products together against their magnetic forces. Do not expose products to strong magnetic fields of more than 30 kA/m.

PINNING

PIN	SYMBOL	DESCRIPTION
1	V_{CC}	DC supply voltage
2	V_{out}	open collector output
3	GND	ground

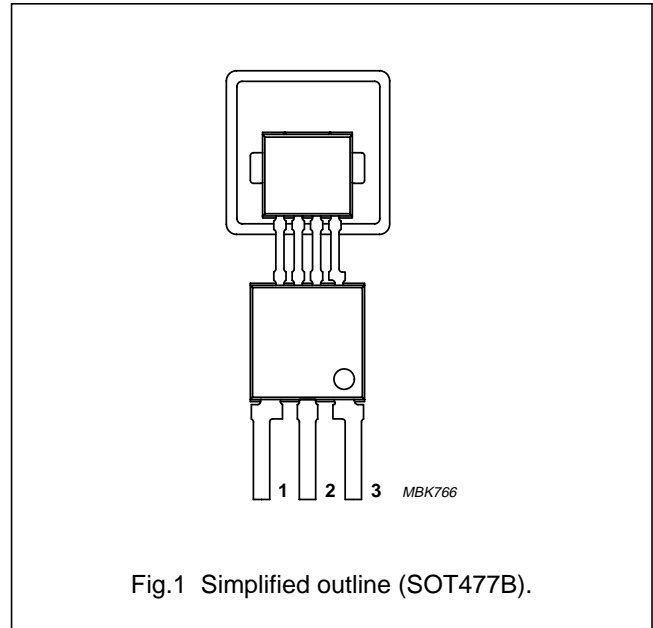

QUICK REFERENCE DATA

SYMBOL	PARAMETER	MIN.	TYP.	MAX.	UNIT
V_{CC}	DC supply voltage	4.5	5	16	V
I_{CC}	DC supply current (pin 1)	4	10	14	mA
V_{CEsat}	OC saturation voltage	–	–	1	V
d_{max}	maximum sensing distance	2.4	2.9	–	mm
f_t	operating tooth frequency	0	–	25000	Hz
T_{amb}	ambient operating temperature	–40	–	+150	°C

Integrated rotational speed sensor

KMI16/1

LIMITING VALUES

In accordance with the Absolute Maximum Rating System (IEC 60134)

SYMBOL	PARAMETER	CONDITIONS	MIN.	MAX.	UNIT
V _{CC}	DC operating supply voltage	T _{amb} = -40 to +150 °C	4.5	16	V
	voltage pin 1	T _{amb} = -40 to +150 °C; no wrong polarity protection	-0.5	+16	V
V _{out}	OC output voltage	T _{amb} = -40 to +150 °C; no wrong polarity protection; see Fig.5	-0.5	+16	V
V _{out(max)}	peak OC output voltage	T _{amb} = -40 to +40 °C; no wrong polarity protection; see Fig.5	-0.5	+26.5	V
I _{out(max)}	OC output current	T _{amb} = -40 to +150 °C	-	20	mA
I _{out(off)}	OC output leakage current	T _{amb} = -40 to +150 °C	-	100	µA
P _{tot}	total power dissipation	T _{amb} = -40 to +150 °C	-	200	mW
T _{sld}	soldering temperature	t ≤ 10 s	-	260	°C
T _{stg}	storage temperature		-65	+150	°C
T _{amb}	ambient operating temperature		-40	+150	°C

CHARACTERISTICS

T_{amb} = 25 °C; V_{CC} = 5 V; d = 1.9 mm; f_t = 2 kHz; test circuit see Fig.5; gear wheel: module 2.08 mm; material 9SMnPb28k; see Fig.6; centred sensor position; see notes 1, 2 and 3; unless otherwise specified.

SYMBOL	PARAMETER	CONDITIONS	MIN.	TYP.	MAX.	UNIT
I _{CC}	supply current (pin 1)	T _{amb} = -40 to +150 °C	4	10	14	mA
V _{out (high)}	OC output voltage high	OC = off state; T _{amb} = -40 to +150 °C	4.7	4.9	-	V
V _{CE sat}	OC saturation voltage	OC = on state; I _{out} = 20 mA	-	0.4	1	V
t _r	output signal rise time	10% to 90%	5	12	20	µs
t _f	output signal fall time	10% to 90%	0.1	0.4	10	µs
δ	duty cycle	T _{amb} = -40 to +150 °C	30	50	70	%
d _{min}	minimum sensing distance	T _{amb} = -40 to +150 °C	-	0.3	0.5	mm
d _{max}	maximum sensing distance	T _{amb} = -40 to +150 °C	2.4	2.9	-	mm

Notes

1. High rotational wheel speeds reduce the maximum sensing distance because of eddy currents, depending on target wheel dimensions and materials used.
2. Output pins are designed for electrostatic sensitivity for more than 2000 V according to Human Body Model (HBM); MIL-STD-883; method 3015.
3. EMC behaviour depends greatly on design of application circuit.

Integrated rotational speed sensor

KMI16/1

FUNCTIONAL DESCRIPTION

The KMI16/1 sensor is sensitive to the motion of ferrous gear wheels or reference marks. The functional principle is shown in Fig.3. Due to the effect of flux bending, the different directions of magnetic field lines in the magnetoresistive sensor element will cause an electrical signal. Because of the chosen sensor orientation and the direction of ferrite magnetization, the KMI16/1 is sensitive to movement in the 'y' direction in front of the sensor only (see Fig.2).

The magnetoresistive sensor element signal is amplified, temperature compensated and passed to a Schmitt trigger in the conditioning integrated circuit (see Fig.4). The digital output signal level is independent of the sensing distance within the measuring range (see Fig.10). A (3-wire) output current enables safe transfer of the sensor signal to the detecting circuit (see Fig.5). The integrated circuit housing is separated from the sensor element housing to optimize the sensor behaviour at high temperatures.

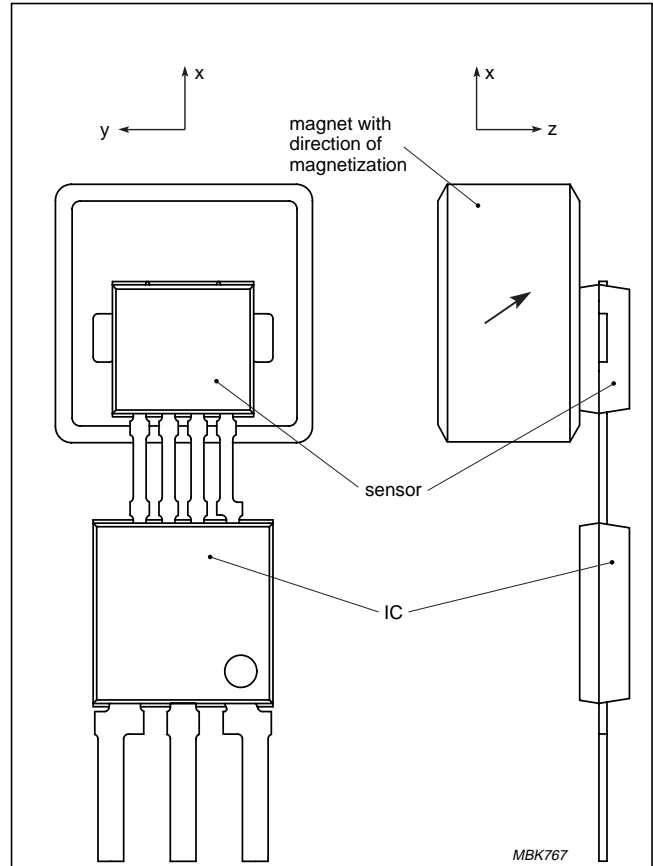

Fig.2 Component detail of the KMI16/1.

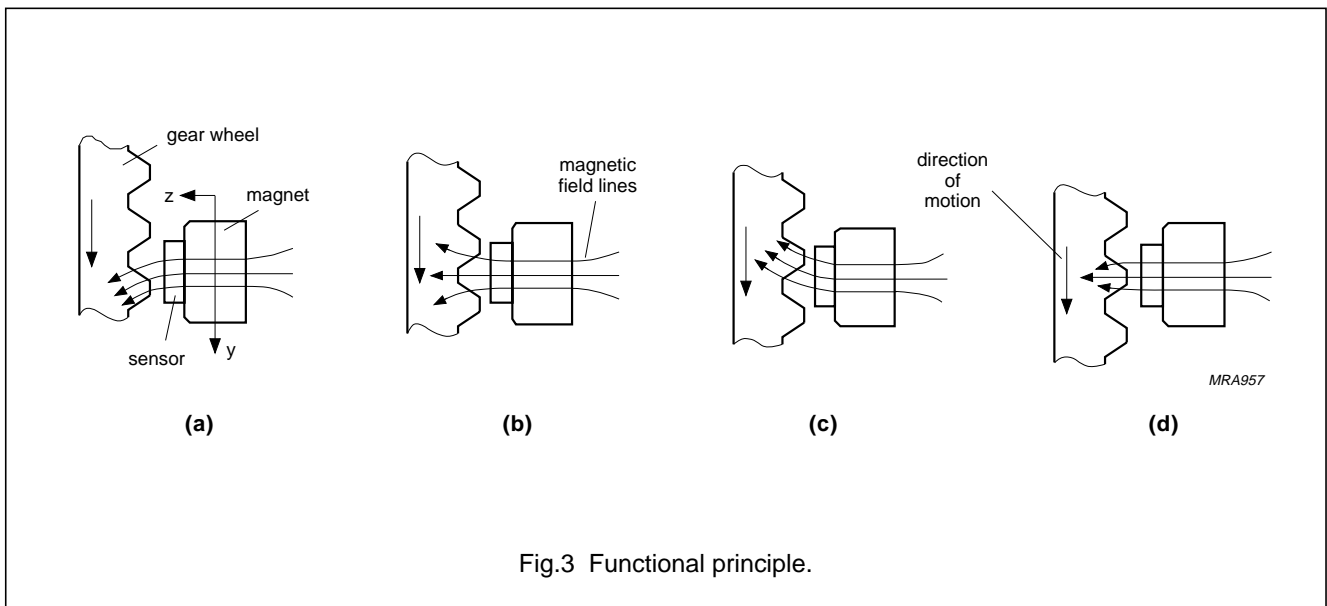
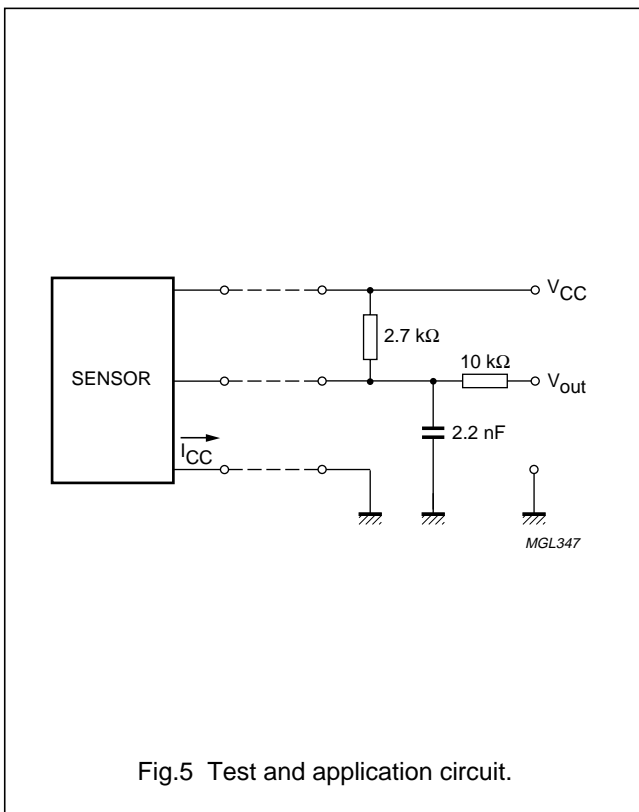
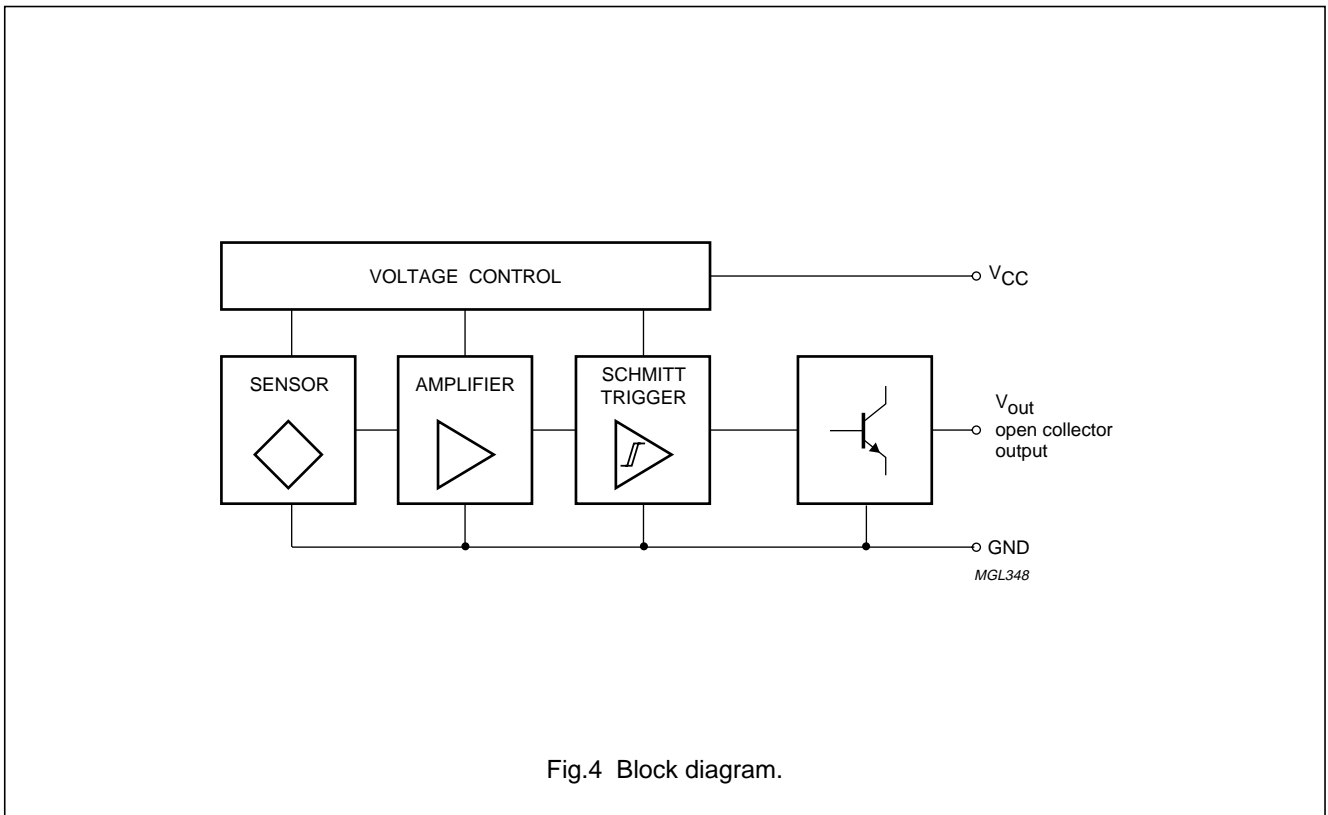

Fig.3 Functional principle.

Integrated rotational speed sensor

KMI16/1



Integrated rotational speed sensor

KMI16/1

APPLICATION INFORMATION

Mounting conditions

The recommended sensor position in front of a gear wheel is shown in Fig.11. The distance 'd' is measured between the sensor front and the tip of a gear wheel tooth. The KMI16/1 senses ferrous indicators like gear wheels in the 'y' direction only (no rotational symmetry of the sensor); see Fig.2. The effect of incorrect mounting positions on sensing distance is shown in Figs 7, 8 and 9. The symmetrical reference axis of the sensor corresponds to the axis of the ferrite magnet.

Environmental conditions

Due to eddy current effects the sensing distance depends on the tooth frequency (see Fig.13). The influence of the gear wheel module on the sensing distance is shown in Fig.12.

Gear Wheel Dimensions

SYMBOL	DESCRIPTION	UNIT
German DIN		
z	number of teeth	–
d	diameter	mm
m	module $m = d/z$	mm
p	pitch $p = \pi \times m$	mm
ASA; note 1		
PD	pitch diameter (d in inch)	inch
DP	diametric pitch $DP = z/PD$	inch ⁻¹
CP	circular pitch $CP = \pi/DP$	inch

Note

- For conversion from ASA to DIN: $m = 25.4 \text{ mm}/DP$; $p = 25.4 \text{ mm} \times CP$.

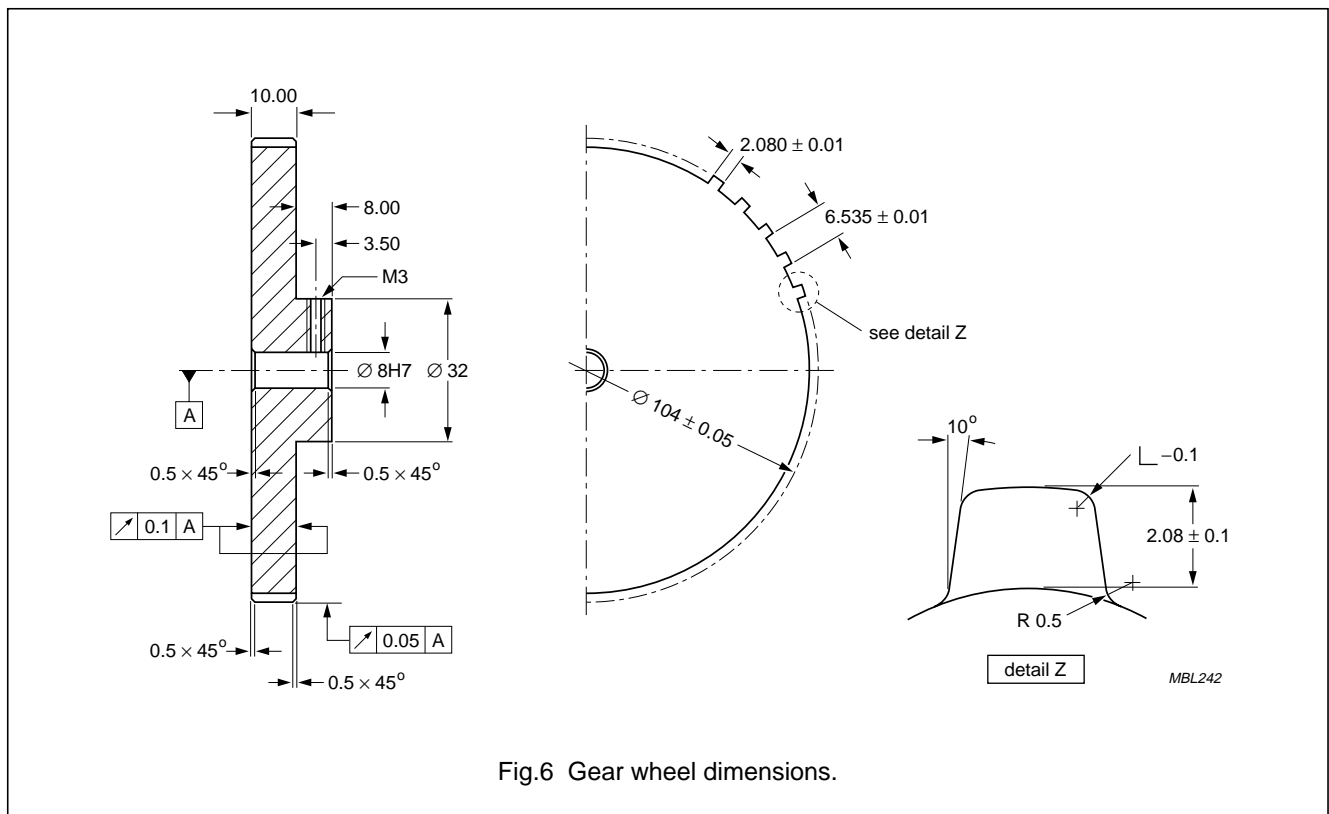
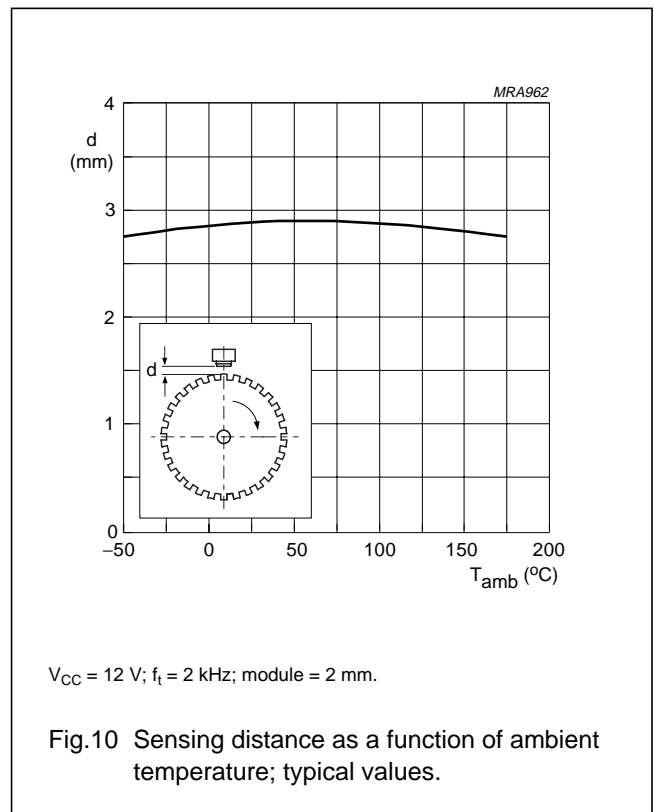
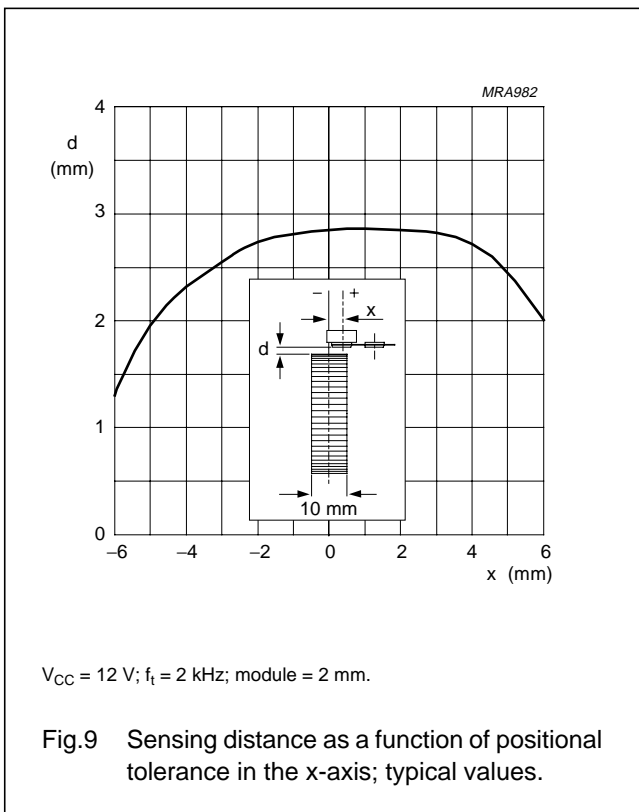
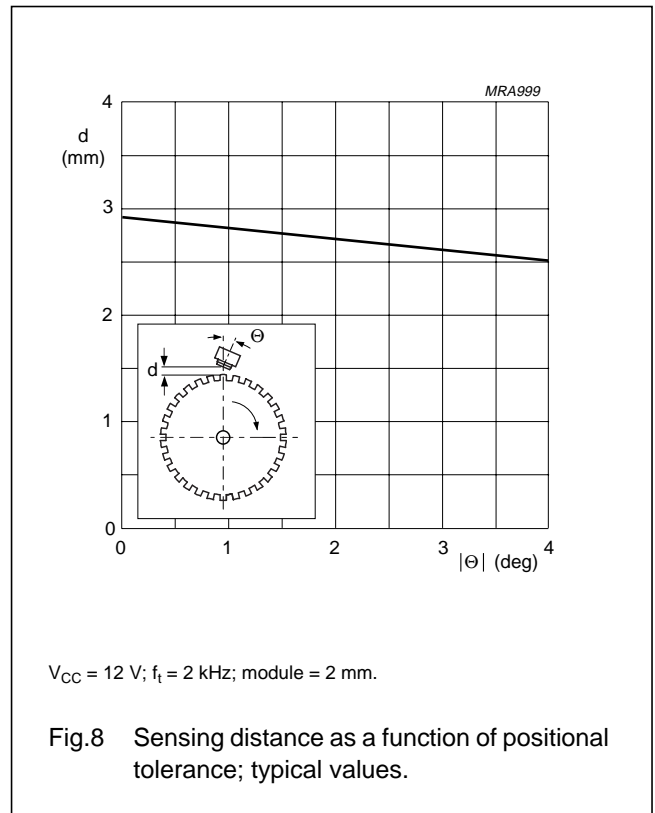
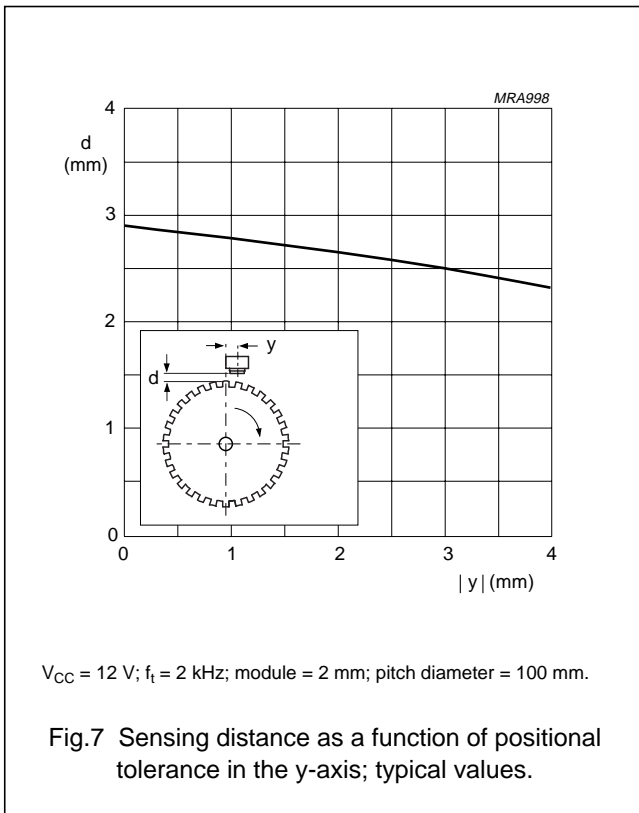

Fig.6 Gear wheel dimensions.

Integrated rotational speed sensor

KMI16/1



Integrated rotational speed sensor

KMI16/1

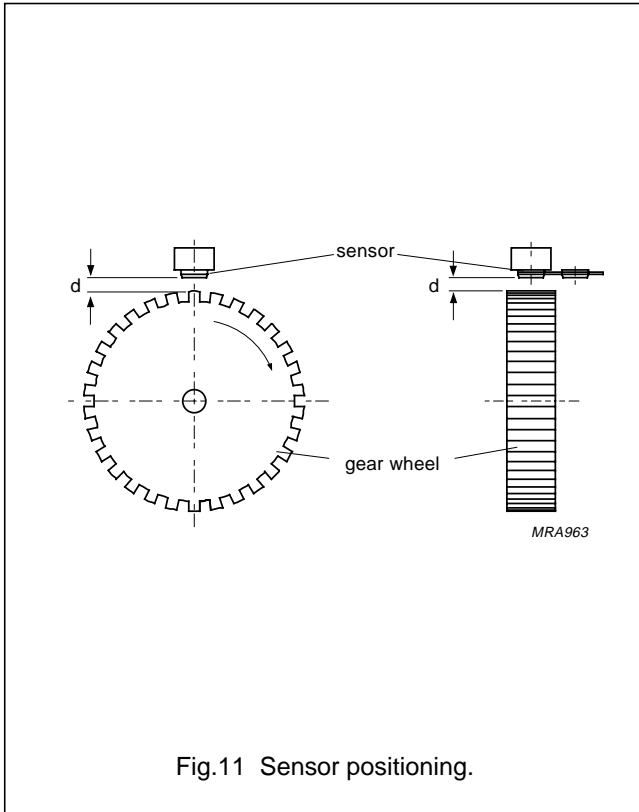
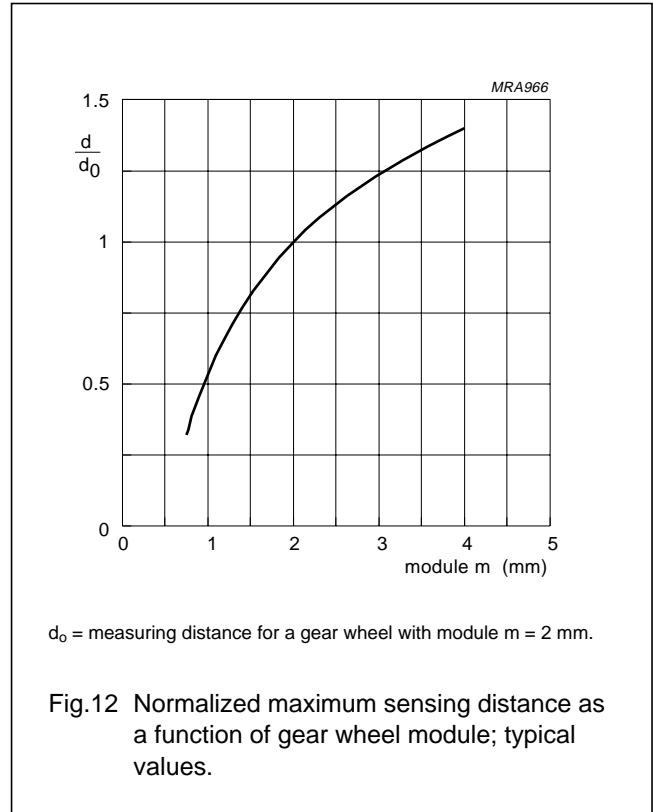
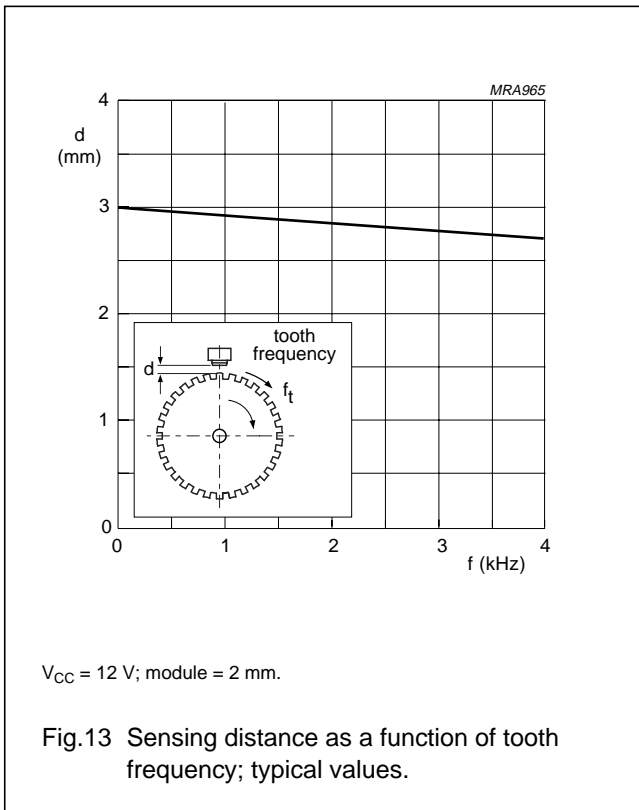

Fig.11 Sensor positioning.



d_0 = measuring distance for a gear wheel with module $m = 2$ mm.

Fig.12 Normalized maximum sensing distance as a function of gear wheel module; typical values.



$V_{CC} = 12$ V; module = 2 mm.

Fig.13 Sensing distance as a function of tooth frequency; typical values.

Integrated rotational speed sensor

KMI16/1

PACKAGE OUTLINE

Plastic single-ended multi-chip package;
magnetized ferrite magnet (8 x 8 x 4.5 mm); 4 interconnections; 3 in-line leads

SOT477B

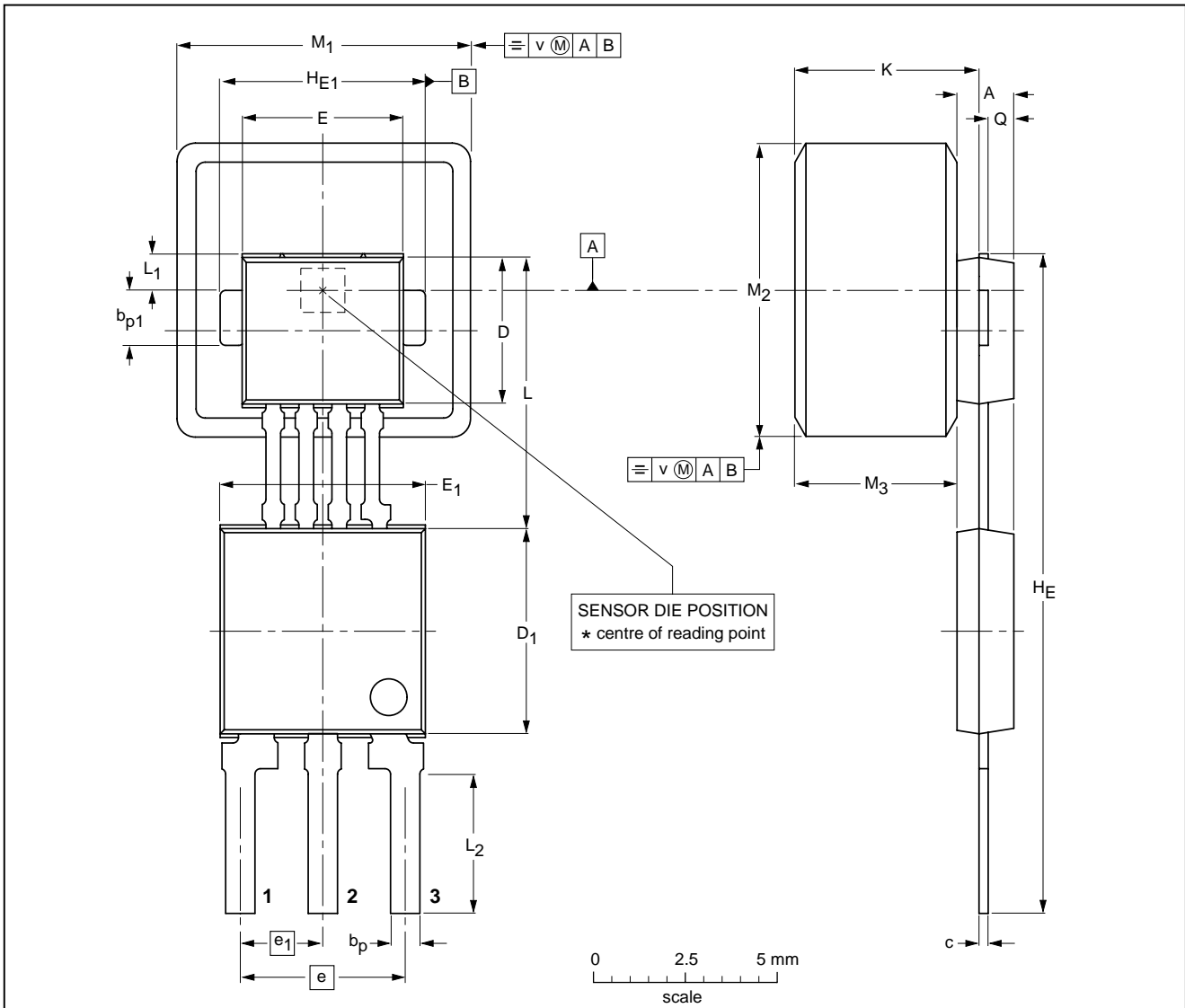

DIMENSIONS (mm are the original dimensions)

UNIT	A ⁽¹⁾	b _p	b _{p1}	c	D ⁽²⁾	D ₁ ⁽²⁾	E ⁽²⁾	E ₁ ⁽²⁾	e	e ₁	H _E	H _{E1}	K _{max.}	L	L ₁	L ₂	M ₁	M ₂	M ₃ ⁽¹⁾	Q	v
mm	1.7 1.4	0.8 0.7	1.57 1.47	0.3 0.24	4.1 3.9	5.7 5.5	4.5 4.3	5.7 5.5	4.6 4.4	2.35 2.15	18.2 17.8	5.6 5.5	5.37	7.55 7.25	1.2 0.9	3.9 3.5	8.15 7.85	8.15 7.85	4.7 4.3	0.75 0.65	0.25

Notes

1. Glue thickness not included.
2. Plastic or metal protrusions of 0.15 mm maximum per side are not included.

OUTLINE VERSION	REFERENCES				EUROPEAN PROJECTION	ISSUE DATE
	IEC	JEDEC	EIAJ			
SOT477B						99-09-23 00-08-31

Integrated rotational speed sensor

KMI16/1

DATA SHEET STATUS

DATA SHEET STATUS	PRODUCT STATUS	DEFINITIONS ⁽¹⁾
Objective specification	Development	This data sheet contains the design target or goal specifications for product development. Specification may change in any manner without notice.
Preliminary specification	Qualification	This data sheet contains preliminary data, and supplementary data will be published at a later date. Philips Semiconductors reserves the right to make changes at any time without notice in order to improve design and supply the best possible product.
Product specification	Production	This data sheet contains final specifications. Philips Semiconductors reserves the right to make changes at any time without notice in order to improve design and supply the best possible product.

Note

1. Please consult the most recently issued data sheet before initiating or completing a design.

DEFINITIONS

Short-form specification — The data in a short-form specification is extracted from a full data sheet with the same type number and title. For detailed information see the relevant data sheet or data handbook.

Limiting values definition — Limiting values given are in accordance with the Absolute Maximum Rating System (IEC 60134). Stress above one or more of the limiting values may cause permanent damage to the device. These are stress ratings only and operation of the device at these or at any other conditions above those given in the Characteristics sections of the specification is not implied. Exposure to limiting values for extended periods may affect device reliability.

Application information — Applications that are described herein for any of these products are for illustrative purposes only. Philips Semiconductors make no representation or warranty that such applications will be suitable for the specified use without further testing or modification.

DISCLAIMERS

Life support applications — These products are not designed for use in life support appliances, devices, or systems where malfunction of these products can reasonably be expected to result in personal injury. Philips Semiconductors customers using or selling these products for use in such applications do so at their own risk and agree to fully indemnify Philips Semiconductors for any damages resulting from such application.

Right to make changes — Philips Semiconductors reserves the right to make changes, without notice, in the products, including circuits, standard cells, and/or software, described or contained herein in order to improve design and/or performance. Philips Semiconductors assumes no responsibility or liability for the use of any of these products, conveys no licence or title under any patent, copyright, or mask work right to these products, and makes no representations or warranties that these products are free from patent, copyright, or mask work right infringement, unless otherwise specified.

Integrated rotational speed sensor

KMI16/1

NOTES

Philips Semiconductors – a worldwide company

Argentina: see South America

Australia: 3 Figtree Drive, HOMEBUSH, NSW 2140,
Tel. +61 2 9704 8141, Fax. +61 2 9704 8139

Austria: Computerstr. 6, A-1101 WIEN, P.O. Box 213,
Tel. +43 1 60 101 1248, Fax. +43 1 60 101 1210

Belarus: Hotel Minsk Business Center, Bld. 3, r. 1211, Volodarski Str. 6,
220050 MINSK, Tel. +375 172 20 0733, Fax. +375 172 20 0773

Belgium: see The Netherlands

Brazil: see South America

Bulgaria: Philips Bulgaria Ltd., Energoproject, 15th floor,
51 James Bourchier Blvd., 1407 SOFIA,
Tel. +359 2 68 9211, Fax. +359 2 68 9102

Canada: PHILIPS SEMICONDUCTORS/COMPONENTS,
Tel. +1 800 234 7381, Fax. +1 800 943 0087

China/Hong Kong: 501 Hong Kong Industrial Technology Centre,
72 Tat Chee Avenue, Kowloon Tong, HONG KONG,
Tel. +852 2319 7888, Fax. +852 2319 7700

Colombia: see South America

Czech Republic: see Austria

Denmark: Sydhavnsgade 23, 1780 COPENHAGEN V,
Tel. +45 33 29 3333, Fax. +45 33 29 3905

Finland: Sinikalliontie 3, FIN-02630 ESPOO,
Tel. +358 9 615 800, Fax. +358 9 6158 0920

France: 51 Rue Carnot, BP317, 92156 SURESNES Cedex,
Tel. +33 1 4099 6161, Fax. +33 1 4099 6427

Germany: Hammerbrookstraße 69, D-20097 HAMBURG,
Tel. +49 40 2353 60, Fax. +49 40 2353 6300

Hungary: see Austria

India: Philips INDIA Ltd, Band Box Building, 2nd floor,
254-D, Dr. Annie Besant Road, Worli, MUMBAI 400 025,
Tel. +91 22 493 8541, Fax. +91 22 493 0966

Indonesia: PT Philips Development Corporation, Semiconductors Division,
Gedung Philips, Jl. Buncit Raya Kav.99-100, JAKARTA 12510,
Tel. +62 21 794 0040 ext. 2501, Fax. +62 21 794 0080

Ireland: Newstead, Clonskeagh, DUBLIN 14,
Tel. +353 1 7640 000, Fax. +353 1 7640 200

Israel: RAPAC Electronics, 7 Kehilat Saloniki St, PO Box 18053,
TEL AVIV 61180, Tel. +972 3 645 0444, Fax. +972 3 649 1007

Italy: PHILIPS SEMICONDUCTORS, Via Casati, 23 - 20052 MONZA (MI),
Tel. +39 039 203 6838, Fax +39 039 203 6800

Japan: Philips Bldg 13-37, Kohnan 2-chome, Minato-ku,
TOKYO 108-8507, Tel. +81 3 3740 5130, Fax. +81 3 3740 5057

Korea: Philips House, 260-199 Itaewon-dong, Yongsan-ku, SEOUL,
Tel. +82 2 709 1412, Fax. +82 2 709 1415

Malaysia: No. 76 Jalan Universiti, 46200 PETALING JAYA, SELANGOR,
Tel. +60 3 750 5214, Fax. +60 3 757 4880

Mexico: 5900 Gateway East, Suite 200, EL PASO, TEXAS 79905,
Tel. +9-5 800 234 7381, Fax +9-5 800 943 0087

Middle East: see Italy

Netherlands: Postbus 90050, 5600 PB EINDHOVEN, Bldg. VB,
Tel. +31 40 27 82785, Fax. +31 40 27 88399

New Zealand: 2 Wagener Place, C.P.O. Box 1041, AUCKLAND,
Tel. +64 9 849 4160, Fax. +64 9 849 7811

Norway: Box 1, Manglerud 0612, OSLO,
Tel. +47 22 74 8000, Fax. +47 22 74 8341

Pakistan: see Singapore

Philippines: Philips Semiconductors Philippines Inc.,
106 Valero St. Salcedo Village, P.O. Box 2108 MCC, MAKATI,
Metro MANILA, Tel. +63 2 816 6380, Fax. +63 2 817 3474

Poland: Al.Jerozolimskie 195 B, 02-222 WARSAW,
Tel. +48 22 5710 000, Fax. +48 22 5710 001

Portugal: see Spain

Romania: see Italy

Russia: Philips Russia, Ul. Usatcheva 35A, 119048 MOSCOW,
Tel. +7 095 755 6918, Fax. +7 095 755 6919

Singapore: Lorong 1, Toa Payoh, SINGAPORE 319762,
Tel. +65 350 2538, Fax. +65 251 6500

Slovakia: see Austria

Slovenia: see Italy

South Africa: S.A. PHILIPS Pty Ltd., 195-215 Main Road Martindale,
2092 JOHANNESBURG, P.O. Box 58088 Newville 2114,
Tel. +27 11 471 5401, Fax. +27 11 471 5398

South America: Al. Vicente Pinzon, 173, 6th floor,
04547-130 SÃO PAULO, SP, Brazil,
Tel. +55 11 821 2333, Fax. +55 11 821 2382

Spain: Balmes 22, 08007 BARCELONA,
Tel. +34 93 301 6312, Fax. +34 93 301 4107

Sweden: Kottbygatan 7, Akalla, S-16485 STOCKHOLM,
Tel. +46 8 5985 2000, Fax. +46 8 5985 2745

Switzerland: Allmendstrasse 140, CH-8027 ZÜRICH,
Tel. +41 1 488 2741 Fax. +41 1 488 3263

Taiwan: Philips Semiconductors, 5F, No. 96, Chien Kuo N. Rd., Sec. 1,
TAIPEI, Taiwan Tel. +886 2 2134 2451, Fax. +886 2 2134 2874

Thailand: PHILIPS ELECTRONICS (THAILAND) Ltd.,
60/14 MOO 11, Bangna Trad Road KM. 3, Bagna, BANGKOK 10260,
Tel. +66 2 361 7910, Fax. +66 2 398 3447

Turkey: Yukari Dudullu, Org. San. Blg., 2.Cad. Nr. 28 81260 Umraniye,
ISTANBUL, Tel. +90 216 522 1500, Fax. +90 216 522 1813

Ukraine: PHILIPS UKRAINE, 4 Patrice Lumumba str., Building B, Floor 7,
252042 KIEV, Tel. +380 44 264 2776, Fax. +380 44 268 0461

United Kingdom: Philips Semiconductors Ltd., 276 Bath Road, Hayes,
MIDDLESEX UB3 5BX, Tel. +44 208 730 5000, Fax. +44 208 754 8421

United States: 811 East Arques Avenue, SUNNYVALE, CA 94088-3409,
Tel. +1 800 234 7381, Fax. +1 800 943 0087

Uruguay: see South America

Vietnam: see Singapore

Yugoslavia: PHILIPS, Trg N. Pasica 5/v, 11000 BEOGRAD,
Tel. +381 11 3341 299, Fax.+381 11 3342 553

For all other countries apply to: Philips Semiconductors,
Marketing Communications, Building BE-p, P.O. Box 218, 5600 MD EINDHOVEN,
The Netherlands, Fax. +31 40 27 24825

Internet: <http://www.semiconductors.philips.com>

© Philips Electronics N.V. 2000

SCA 70

All rights are reserved. Reproduction in whole or in part is prohibited without the prior written consent of the copyright owner.

The information presented in this document does not form part of any quotation or contract, is believed to be accurate and reliable and may be changed without notice. No liability will be accepted by the publisher for any consequence of its use. Publication thereof does not convey nor imply any license under patent- or other industrial or intellectual property rights.

Printed in The Netherlands

613520/02/pp12

Date of release: 2000 Sep 05

Document order number: 9397 750 07248

Let's make things better.

Philips
Semiconductors



PHILIPS

Mouser Electronics

Authorized Distributor

Click to View Pricing, Inventory, Delivery & Lifecycle Information:

NXP:

[KMI16/1,115](#) [KMI16/1/V3PX](#)

Данный компонент на территории Российской Федерации

Вы можете приобрести в компании MosChip.

Для оперативного оформления запроса Вам необходимо перейти по данной ссылке:

<http://moschip.ru/get-element>

Вы можете разместить у нас заказ для любого Вашего проекта, будь то серийное производство или разработка единичного прибора.

В нашем ассортименте представлены ведущие мировые производители активных и пассивных электронных компонентов.

Нашей специализацией является поставка электронной компонентной базы двойного назначения, продукции таких производителей как XILINX, Intel (ex.ALTERA), Vicor, Microchip, Texas Instruments, Analog Devices, Mini-Circuits, Amphenol, Glenair.

Сотрудничество с глобальными дистрибьюторами электронных компонентов, предоставляет возможность заказывать и получать с международных складов практически любой перечень компонентов в оптимальные для Вас сроки.

На всех этапах разработки и производства наши партнеры могут получить квалифицированную поддержку опытных инженеров.

Система менеджмента качества компании отвечает требованиям в соответствии с ГОСТ Р ИСО 9001, ГОСТ РВ 0015-002 и ЭС РД 009

Офис по работе с юридическими лицами:

105318, г.Москва, ул.Щербаковская д.3, офис 1107, 1118, ДЦ «Щербаковский»

Телефон: +7 495 668-12-70 (многоканальный)

Факс: +7 495 668-12-70 (доб.304)

E-mail: info@moschip.ru

Skype отдела продаж:

moschip.ru

moschip.ru_4

moschip.ru_6

moschip.ru_9