

MULTILAYER FERRITE CHIP BEAD

ACML-0402



RoHS
Compliant



1.00 x 0.50 x 0.50mm

FEATURES:

- Magnetic shielded structure designed to minimize crosstalk
- Multilayer monolithic structure yields high reliability
- Substantial EMI suppression from dozens of MHz to hundreds of MHz
- Wide range of impedance values available

APPLICATIONS:

- Noise suppression in digital equipment such as computer and its peripheral devices, DVD player, digital camera, TV and communication equipments.

STANDARD SPECIFICATIONS:

PARAMETERS

ABRACON P/N:	ACML-0402
Operating temperature:	-55°C to +125°C
Storage temperature:	-10°C to +40°C

Part Number ACML-0402- Impedance Code	Impedance	Frequency	DC resistance	Rated Current
Units	$\Omega \pm 25\%$	MHz	Ω max	mA max
Symbol	Z	F	R _{DC}	I _R
ACML-0402-050	5	100	0.05	500
ACML-0402-070	7	100	0.05	500
ACML-0402-110	11	100	0.05	500
ACML-0402-190	19	100	0.05	300
ACML-0402-310	31	100	0.20	300
ACML-0402-600	60	100	0.30	200
ACML-0402-800	80	100	0.35	200
ACML-0402-121	120	100	0.40	150
ACML-0402-181	180	100	0.50	150
ACML-0402-221	220	100	0.45	150
ACML-0402-241	240	100	0.60	125
ACML-0402-301	300	100	0.65	100
ACML-0402-471	470	100	0.80	100
ACML-0402-501	500	100	0.80	100
ACML-0402-601	600	100	1.00	100
ACML-0402-102	1000	100	1.30	100
ACML-0402-152	1500	100	1.60	100

Test Conditions and Equipments

I_R: Rated current applied when the chip surface temperature rise 20°C. Electric power supplier, Electric current meter, Thermometer.

Z: Impedance Analyzer HP4291 or equivalent, 50mV.

DCR: LCR Meter HP4263A or equivalent

OPTIONS AND PART IDENTIFICATION:

ACML-0402 - -

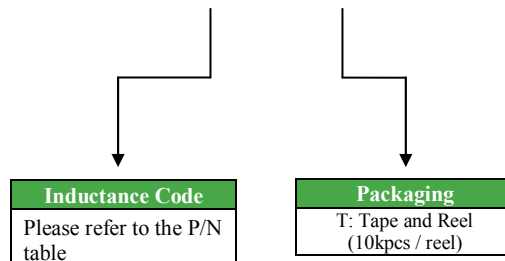

ABRACON IS
ISO 9001:2008
CERTIFIED



Visit www.abracon.com for Terms & Conditions of Sale **Revised: 01.03.13**
30332 Esperanza, Rancho Santa Margarita, California 92688
tel 949-546-8000 | fax 949-546-8001 | www.abracon.com

MULTILAYER FERRITE CHIP BEAD

ACML-0402



RoHS
Compliant

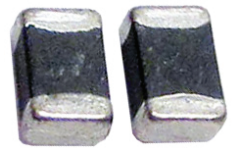

1.00 x 0.50 x 0.50mm

FREQUENCY RESPONSE



OUTLINE DIMENSIONS:

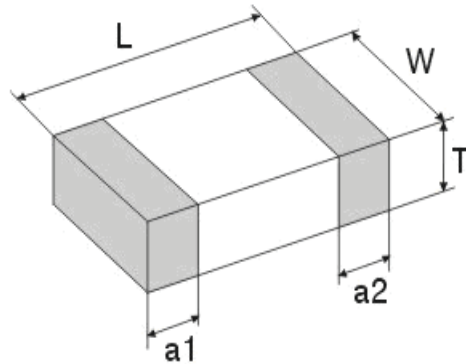

L	W	T	a1, a2
1.00±0.15	0.50±0.15	0.50±0.15	0.25±0.10

Materials



	Part Name	Material
1	Base Material	Ferrite
2	Internal Conductor	Ag
3	Terminal Electrode	Ag
4	Terminal Electrode	Ni-Sn

Dimension: mm

ABRACON IS
ISO 9001:2008
CERTIFIED



ABRACON
CORPORATION

Visit www.abracon.com for Terms & Conditions of Sale **Revised: 01.03.13**
30332 Esperanza, Rancho Santa Margarita, California 92688
tel 949-546-8000 | fax 949-546-8001 | www.abracon.com

MULTILAYER FERRITE CHIP BEAD

ACML-0402



RoHS
Compliant



1.00 x 0.50 x 0.50mm

REFLOW PROFILE:



Profile Feature	Lead-Free Assembly
Time maintained above: - Temperature (TL) - Time (tL)	217 °C 60-150 seconds
Peak/Classification Temperature (Tp) Peak/Classification Time (tp)	260 °C 3-4 seconds
Time within 5 °C of actual Peak Temperature (tp)	20-40 seconds
Ramp-Down Rate	6°C/second max.
Time 25 °C to Peak Temperature	8 minutes max.

TAPE & REEL: Tape and reel 10,000pcs/reel



A	0.65±0.15
B	1.3±0.15
C	8.0±0.3
D	3.5±0.05
E	1.75±0.1
F	2.0±0.05
G	2.0±0.05
H	4.0±0.1
ΦJ	1.5+0.1/-0
t(max)	0.8±0.05



A	178±2
B	60±2
C	13.0±0.5
D	21.0±0.8
E	2.0±0.5
W	10.0±1.15
t	1.2±0.2
R	1.0±0.25

Dimensions: mm

ATTENTION: Abracon Corporation's products are COTS – Commercial-Off-The-Shelf products; suitable for Commercial, Industrial and, where designated, Automotive Applications. Abracon's products are not specifically designed for Military, Aviation, Aerospace, Life-dependant Medical applications or any application requiring high reliability where component failure could result in loss of life and/or property. For applications requiring high reliability and/or presenting an extreme operating environment, written consent and authorization from Abracon Corporation is required. Please contact Abracon Corporation for more information.

ABRACON IS
ISO 9001:2008
CERTIFIED



ABRACON
CORPORATION

Visit www.abracon.com for Terms & Conditions of Sale **Revised: 01.03.13**
30332 Esperanza, Rancho Santa Margarita, California 92688
tel 949-546-8000 | fax 949-546-8001 | www.abracon.com

Данный компонент на территории Российской Федерации

Вы можете приобрести в компании MosChip.

Для оперативного оформления запроса Вам необходимо перейти по данной ссылке:

<http://moschip.ru/get-element>

Вы можете разместить у нас заказ для любого Вашего проекта, будь то серийное производство или разработка единичного прибора.

В нашем ассортименте представлены ведущие мировые производители активных и пассивных электронных компонентов.

Нашей специализацией является поставка электронной компонентной базы двойного назначения, продукции таких производителей как XILINX, Intel (ex.ALTERA), Vicor, Microchip, Texas Instruments, Analog Devices, Mini-Circuits, Amphenol, Glenair.

Сотрудничество с глобальными дистрибьюторами электронных компонентов, предоставляет возможность заказывать и получать с международных складов практически любой перечень компонентов в оптимальные для Вас сроки.

На всех этапах разработки и производства наши партнеры могут получить квалифицированную поддержку опытных инженеров.

Система менеджмента качества компании отвечает требованиям в соответствии с ГОСТ Р ИСО 9001, ГОСТ РВ 0015-002 и ЭС РД 009

Офис по работе с юридическими лицами:

105318, г.Москва, ул.Щербаковская д.3, офис 1107, 1118, ДЦ «Щербаковский»

Телефон: +7 495 668-12-70 (многоканальный)

Факс: +7 495 668-12-70 (доб.304)

E-mail: info@moschip.ru

Skype отдела продаж:

moschip.ru

moschip.ru_4

moschip.ru_6

moschip.ru_9