



LEOPARD IMAGING INC

Rev 1.1

# LI-TX1-KIT-IMX185-LED

## Data Sheet

### Key Features

- Compatible with Nvidia Jetson TX1
- MIPI interface
- Support up to three IMX185 cameras
- Sony Diagonal 8.58mm Type 1/1.9 CMOS Image Sensor IMX185LQJ
- Length of the I-PEX cable: 300mm
- Support CS lens
- Provide customization services
- Weight: 92 g
- Part#: **LI-TX1-KIT-IMX185-LED**



### BOM

#	Items	QTY
1	LI-JTX1-MIPI-ADPT	1
2	LI-IMX185-MIPI-CS	1
3	LI-TX1-LED-BOARD LED Part#: SFH4556	1
4	FAW-1233-03 cable	1
5	DC 12V Power supply	1

### Lens Spec

- Model: ES0522F.IR
- Focal length: 5.0 mm
- Aperture, F/#: 2.2
- Built in 650nm IR cut filter
- FOV (D/H/V): 102° / 90° / 50°
- TV Distortion: < -8%
- Mount Type: CS

### Dimensions (LI-JTX1-MIPI-ADPT)

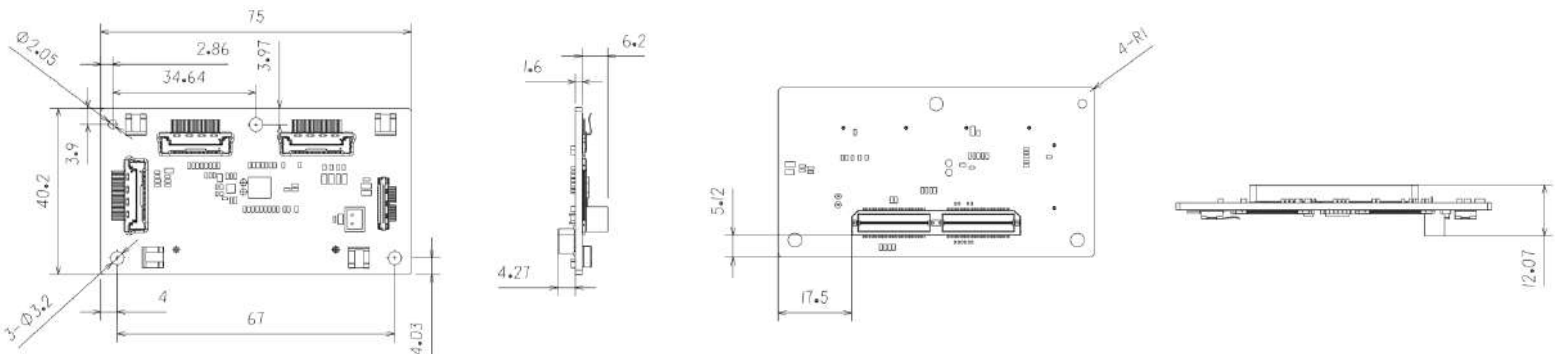

Leopard Imaging Inc.

1130 Cadillac Ct., Milpitas, CA 95035, USA  
 Phone: +1-408-263-0988  
 Fax: +1-408-217-1960  
 Email: sales@leopardimaging.com  
 Website: www.leopardimaging.com  
 www.leopard-security.com

## Dimensions (LI-IMX185-MIPI)

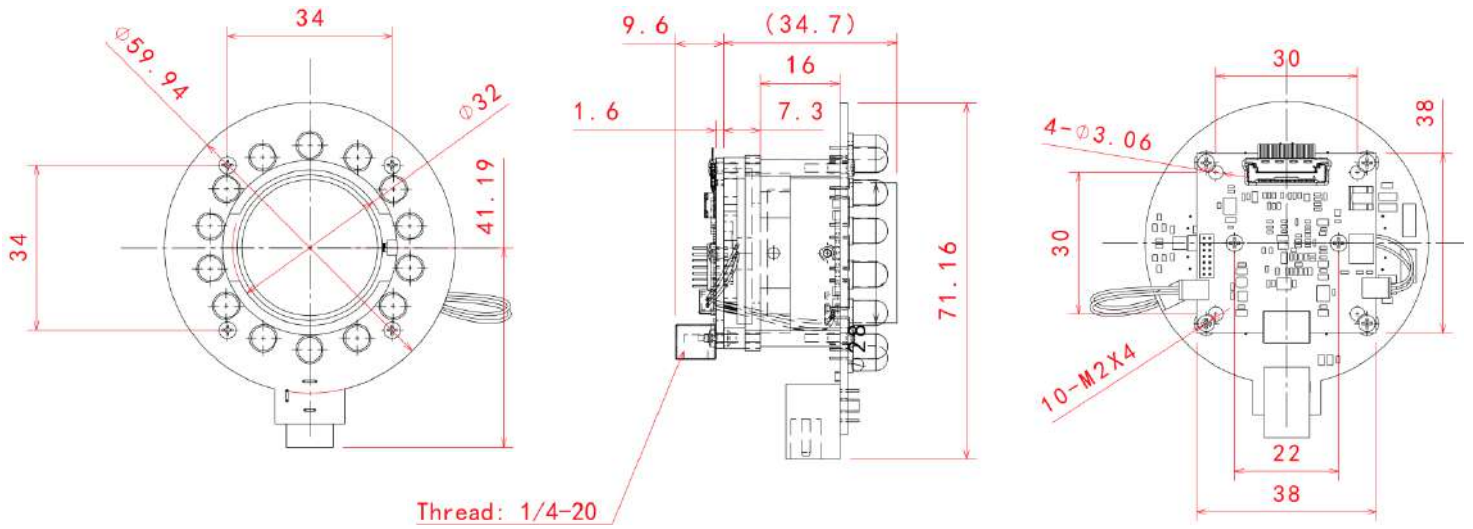

## Dimensions (FAW-1233-03)

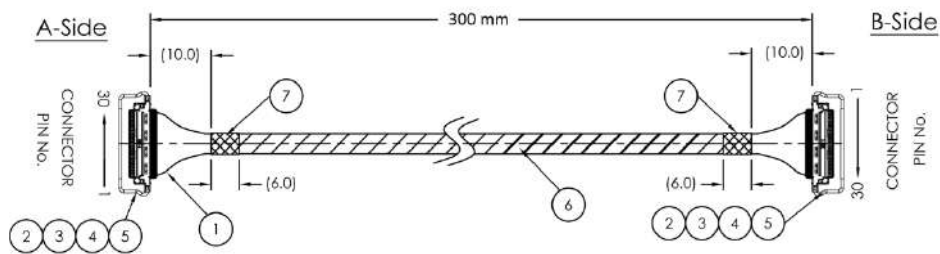

## Work on Nvidia Jetson TX1

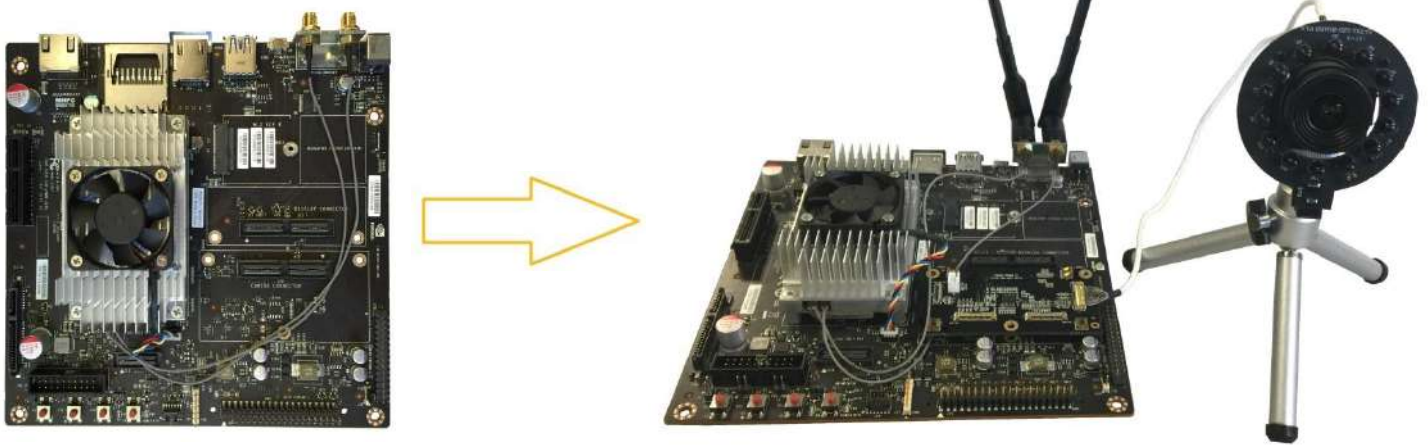

Leopard Imaging Inc.

1130 Cadillac Ct., Milpitas, CA 95035, USA  
 Phone: +1-408-263-0988  
 Fax: +1-408-217-1960  
 Email: sales@leopardimaging.com  
 Website: www.leopardimaging.com  
 www.leopard-security.com

# LI-JTX1-MIPI-ADPT



## Interfaces

### Interface J1

- Part#: 20525-030E-02C
- Number of Positions: 30
- Pitch: 0.4mm
- Mating I-PEX cable: FAW-1233-03 (300mm)

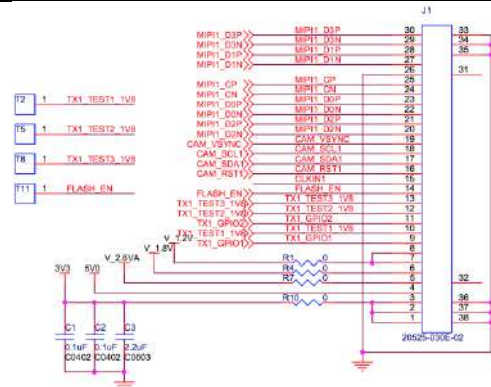

### Interface J2

- Part#: 20525-030E-02C
- Number of Positions: 30
- Pitch: 0.4mm
- Mating I-PEX cable: FAW-1233-03 (300mm)

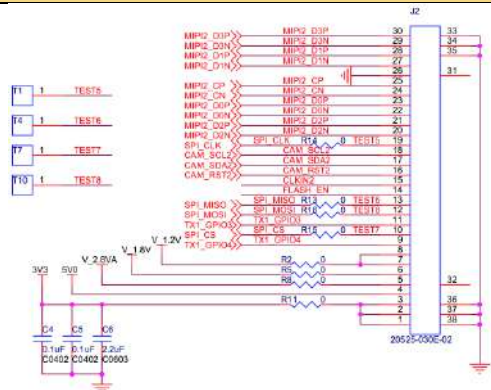

### Interface J3

- Part#: 20525-030E-02C
- Number of Positions: 30
- Pitch: 0.4mm
- Mating I-PEX cable: FAW-1233-03 (300mm)

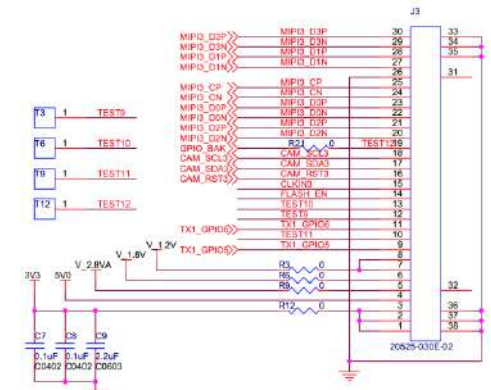

Leopard Imaging Inc.

1130 Cadillac Ct., Milpitas, CA 95035, USA  
Phone: +1-408-263-0988  
Fax: +1-408-217-1960  
Email: sales@leopardimaging.com  
Website: www.leopardimaging.com  
www.leopard-security.com

# Interface J10

- Part#: QTH-060-01-L-D-A
- Number of Positions: 120
- Number of Rows: 2
- Pitch: 0.5 mm

## Vertical Mating Connector of Jetson TX1 J22

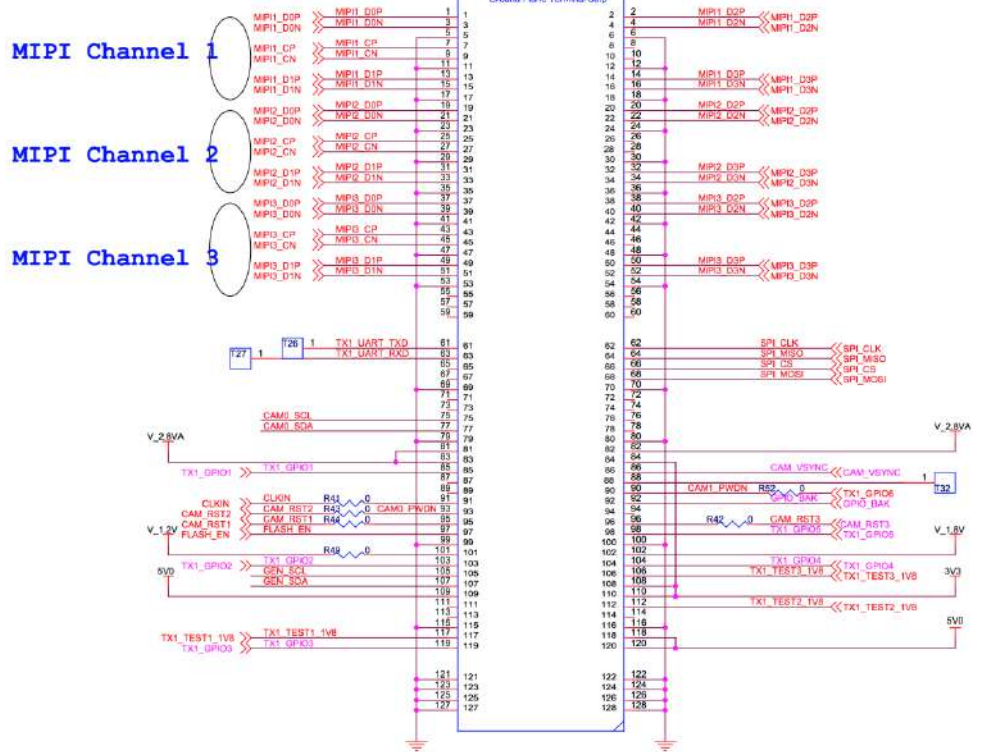

Leopard Imaging Inc.

1130 Cadillac Ct., Milpitas, CA 95035, USA  
 Phone: +1-408-263-0988  
 Fax: +1-408-217-1960  
 Email: sales@leopardimaging.com  
 Website: www.leopardimaging.com  
 www.leopard-security.com

# LI-IMX185-MIPI



Camera Spec	
Image Sensor	Sony Diagonal 8.58 mm (Type 1/1.9) Solid-state Image Sensor IMX185
Optical format	1/1.9"
Number of active pixels	1952 (H) x 1243 (V)
Pixel size	3.75um (H) x 3.75um (V)
Color or Mono	Color
Interface	MIPI interface
Lens mount	CS
IR switcher	Support
Weight	72 g
Interfaces	
Interface J2:	<ul style="list-style-type: none"> <li>Part#: 20525-030E-02C</li> <li>Number of Positions: 30</li> <li>Pitch: 0.4mm</li> <li>Mating I-PEX cable: FAW-1233-03 (300mm)</li> </ul>
Interface J3:	<ul style="list-style-type: none"> <li>Part#: 1734829-2</li> <li>Number of Positions: 2</li> <li>Pitch: 1.25mm</li> </ul>
Interface J5:	<ul style="list-style-type: none"> <li>Part#: 1734829-2</li> <li>Number of Positions: 2</li> <li>Pitch: 1.25mm</li> </ul>



Leopard Imaging Inc.

1130 Cadillac Ct., Milpitas, CA 95035, USA  
 Phone: +1-408-263-0988  
 Fax: +1-408-217-1960  
 Email: sales@leopardimaging.com  
 Website: www.leopardimaging.com  
 www.leopard-security.com

## Absolute Maximum Ratings

Item	Symbol	Min.	Max.	Unit	Remarks
Supply voltage (analog 3.3 V)	AV <sub>DD</sub>	-0.3	4.0	V	
Supply voltage (digital 1.8 V)	OV <sub>DD</sub>	-0.3	3.3	V	
Supply voltage (digital 1.2 V)	DV <sub>DD</sub>	-0.3	2.0	V	
Input voltage	VI	-0.3	OV <sub>DD</sub> + 0.3	V	Not exceed 3.3 V
Output voltage	VO	-0.3	OV <sub>DD</sub> + 0.3	V	Not exceed 3.3 V
Guaranteed operating temperature	Topr	-30	+75	°C	
Storage guarantee temperature	Tstg	-40	+80	°C	
Performance guarantee temperature	Tspec	-10	+60	°C	

## Recommended Operating Conditions

Item	Symbol	Min.	Typ.	Max.	Unit
Supply voltage (analog 3.3 V)	AV <sub>DD</sub>	3.15	3.3	3.45	V
Supply voltage (digital 1.8 V)	OV <sub>DD</sub>	1.7	1.8	1.9	V
Supply voltage (digital 1.2 V)	DV <sub>DD</sub>	1.1	1.2	1.3	V

## Spectral Sensitivity Characteristics

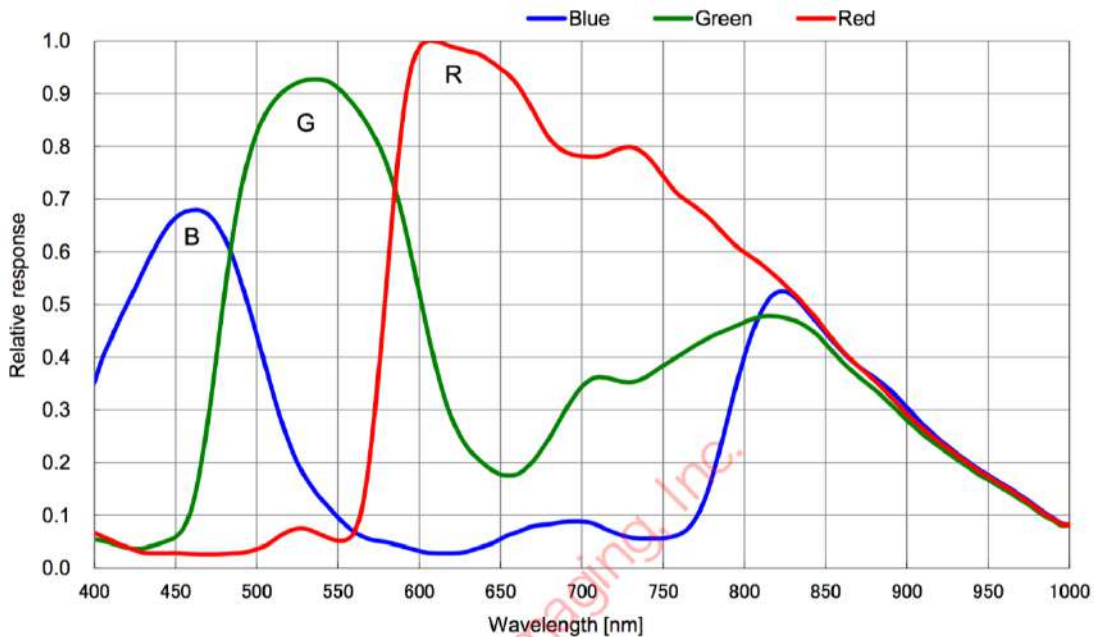

Leopard Imaging Inc.

1130 Cadillac Ct., Milpitas, CA 95035, USA  
 Phone: +1-408-263-0988  
 Fax: +1-408-217-1960  
 Email: sales@leopardimaging.com  
 Website: www.leopardimaging.com  
 www.leopard-security.com

## DC Characteristics

Item	Pins	Symbol	Conditions	Min.	Typ.	Max.	Unit
Supply voltage	Analog	V <sub>DDHx</sub>	AV <sub>DD</sub>	3.15	3.30	3.45	V
	Digital	V <sub>DDMx</sub>	OV <sub>DD</sub>	1.70	1.80	1.90	V
	Digital	V <sub>DDLx</sub>	DV <sub>DD</sub>	1.10	1.20	1.30	V
Digital input voltage	XHS XVS XCLR INCK XMASTER OMODE SCK/SCL SDI/SDA XCE	VIH	XVS/XHS in slave mode	0.8 × OV <sub>DD</sub>	—	—	V
		VIL		—	—	0.2 × OV <sub>DD</sub>	V
Digital output voltage	DOP [11:0] DOM [11:0] DCKP DCKM	VCM	Low voltage LVDS	—	OV <sub>DD</sub> /2	—	V
		VOD	Low voltage LVDS (Termination resistance 100 Ω)	100	150	200	mV
	XHS XVS SDO	VOH	XVS/XHS in master mode	OV <sub>DD</sub> -0.4	—	—	V
		VOL		—	—	0.4	V

## Power Consumption

Item	Pins	Symbol	Typ.		Max.		Unit
			Standard luminous intensity	Saturated luminous intensity	Standard luminous intensity	Saturated luminous intensity	
Operating current CSI-2 serial output 4 Lane 12 bit, 60 frame/s 1080p-HD mode	V <sub>DDH</sub>	IAV <sub>DD</sub>	88	88	113	113	mA
	V <sub>DDM</sub>	IOV <sub>DD</sub>	2	2	4	4	mA
	V <sub>DDL</sub>	IDV <sub>DD</sub>	110	130	150	190	mA
Standby current	V <sub>DDH</sub>	IAV <sub>DD_STB</sub>	—	—	0.2		mA
	V <sub>DDM</sub>	IOV <sub>DD_STB</sub>	—	—	0.1		mA
	V <sub>DDL</sub>	IDV <sub>DD_STB</sub>	—	—	7.0		mA

Operating current:

(Typical value condition) : Supply voltage 3.3 V / 1.8 V / 1.2 V, T<sub>j</sub> = 25 °C

(Maximum value condition) : Supply voltage 3.45 V / 1.9 V / 1.3 V, worst state of internal circuit operating current consumption, T<sub>j</sub> = 60 °C

Standby (Maximum value condition) : Supply voltage 3.45 V / 1.9 V / 1.3 V, T<sub>j</sub> = 60 °C, INCK = 0 V

Standard luminous intensity: luminous intensity at standard imaging condition I

Saturated luminous intensity: luminous intensity when the sensor is saturated.



Leopard Imaging Inc.

1130 Cadillac Ct., Milpitas, CA 95035, USA

Phone: +1-408-263-0988

Fax: +1-408-217-1960

Email: sales@leopardimaging.com

Website: www.leopardimaging.com

www.leopard-security.com

# AC Specification

## INCK

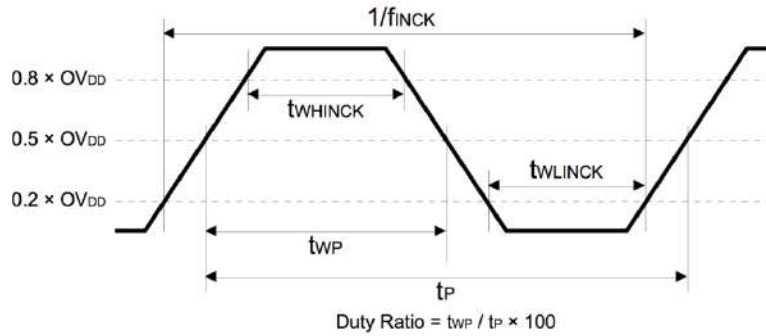

Item	Symbol	Min.	Typ.	Max.	Unit	Remarks
INCK clock frequency	$f_{INCK}$	$f_{INCK} \times 0.96$	$f_{INCK}$	$f_{INCK} \times 1.02$	MHz	$f_{INCK} = 27 \text{ MHz}, 54 \text{ MHz}, 37.125 \text{ MHz}, 74.25 \text{ MHz}$
INCK Low level width	$t_{WLINCK}$	4	—	—	ns	$f_{INCK} = 27 \text{ MHz}, 54 \text{ MHz}, 37.125 \text{ MHz}, 74.25 \text{ MHz}$
INCK High level width	$t_{WHINCK}$	4	—	—	ns	$f_{INCK} = 27 \text{ MHz}, 54 \text{ MHz}, 37.125 \text{ MHz}, 74.25 \text{ MHz}$
INCK clock duty	—	45.0	50.0	55.0	%	Define with $0.5 \times OV_{DD}$

\*The INCK fluctuation affects the frame rate.

## XHS, XVS Input Characteristics In Slave Mode (XMASTER pin = High)

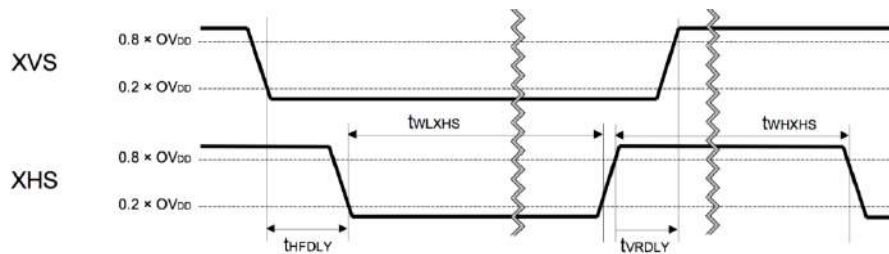

Item	Symbol	Min.	Typ.	Max.	Unit	Remarks
XHS Low level pulse width	$t_{WLXHS}$	$4 / f_{INCK}$	—	—	ns	
XHS High level pulse width	$t_{WHXHS}$	$4 / f_{INCK}$	—	—	ns	
XVS-XHS fall width	$t_{HFDLY}$	$1 / f_{INCK}$	—	—	ns	
XHS-XVS rise width	$t_{VRDLY}$	$1 / f_{INCK}$	—	—	ns	



Leopard Imaging Inc.

1130 Cadillac Ct., Milpitas, CA 95035, USA  
 Phone: +1-408-263-0988  
 Fax: +1-408-217-1960  
 Email: sales@leopardimaging.com  
 Website: www.leopardimaging.com  
 www.leopard-security.com



## I<sup>2</sup>C Communication

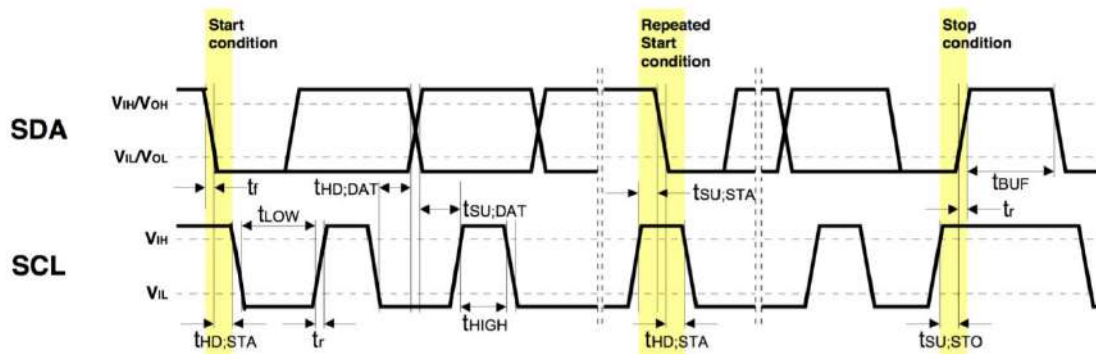

### I<sup>2</sup>C Specification

Item	Symbol	Min.	Typ.	Max.	Unit	Remarks
Low level input voltage	$V_{IL}$	-0.3	—	$0.3 \times OV_{DD}$	V	
High level input voltage	$V_{IH}$	$0.7 \times OV_{DD}$	—	1.9	V	
Low level output voltage	$V_{OL}$	0	—	$0.2 \times OV_{DD}$	V	$OV_{DD} < 2\text{ V}$ , Sink 3 mA
High level output voltage	$V_{OH}$	$0.8 \times OV_{DD}$	—	—	V	
Output fall time	$t_{of}$	—	—	250	ns	Load 10 pF – 400 pF, $0.7 \times OV_{DD} - 0.3 \times OV_{DD}$
Input current	$i_i$	-10	—	10	$\mu\text{A}$	$0.1 \times OV_{DD} - 0.9 \times OV_{DD}$
Capacitance for SCK (/SCL) , SDI (/SDA)	$C_i$	—	—	10	pF	

### I<sup>2</sup>C AC Characteristics

Item	Symbol	Min.	Typ.	Max.	Unit
SCL clock frequency	$f_{SCL}$	0	—	400	kHz
Hold time (Start Condition)	$t_{HDSTA}$	0.6	—	—	$\mu\text{s}$
Low period of the SCL clock	$t_{LOW}$	1.3	—	—	$\mu\text{s}$
High period of the SCL clock	$t_{HIGH}$	0.6	—	—	$\mu\text{s}$
Set-up time (Repeated Start Condition)	$t_{SUSTA}$	0.6	—	—	$\mu\text{s}$
Data hold time	$t_{HDDAT}$	0	—	0.9	$\mu\text{s}$
Data set-up time	$t_{SUDAT}$	100	—	—	ns
Rise time of both SDA and SCL signals	$t_R$	—	—	300	ns
Fall time of both SDA and SCL signals	$t_F$	—	—	300	ns
Set-up time (Stop Condition)	$t_{SUSTO}$	0.6	—	—	$\mu\text{s}$
Bus free time between a Stop and Start Condition	$t_{BUF}$	1.3	—	—	$\mu\text{s}$



Leopard Imaging Inc.

1130 Cadillac Ct., Milpitas, CA 95035, USA  
 Phone: +1-408-263-0988  
 Fax: +1-408-217-1960  
 Email: sales@leopardimaging.com  
 Website: www.leopardimaging.com  
 www.leopard-security.com

# Power-on Sequence

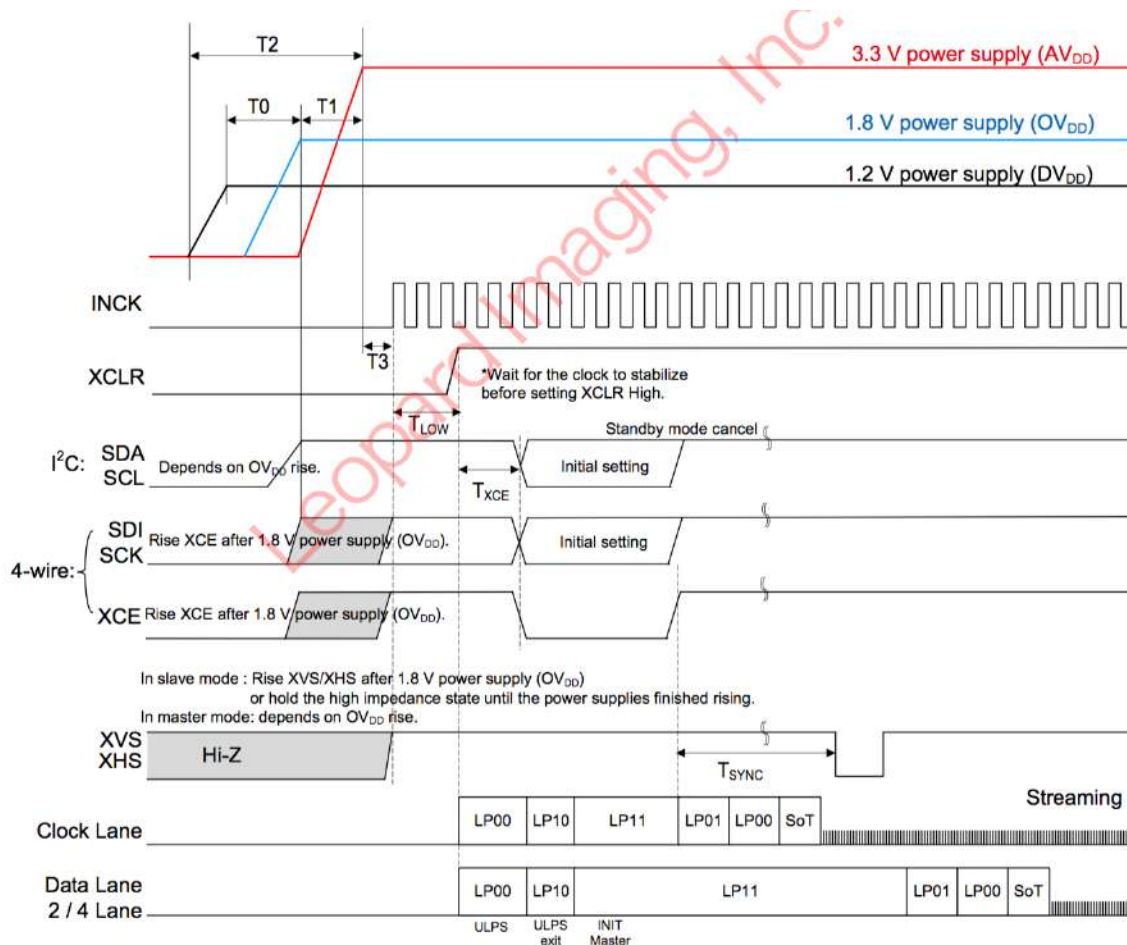

Item	Symbol	Min.	Max.	Unit
1.2 V power supply rising → 1.8 V power supply rising	T <sub>0</sub>	0	—	ns
1.8 V power supply rising → 3.3 V power supply rising	T <sub>1</sub>	0	—	ns
Rising time of all power supply	T <sub>2</sub>	—	200	ms
All power supply rising → External input time of INCK	T <sub>3</sub>	0	—	ns
INCK active → Clear OFF	T <sub>LOW</sub>	500	—	ns
Clear OFF → Communication start	T <sub>XCE</sub>	20	—	μs
Standby OFF (communication) → External input XHS, XVS (slave mode only)	T <sub>SYNC</sub>	20	—	ms



Leopard Imaging Inc.

1130 Cadillac Ct., Milpitas, CA 95035, USA  
 Phone: +1-408-263-0988  
 Fax: +1-408-217-1960  
 Email: sales@leopardimaging.com  
 Website: www.leopardimaging.com  
 www.leopard-security.com

# Power-off Sequence

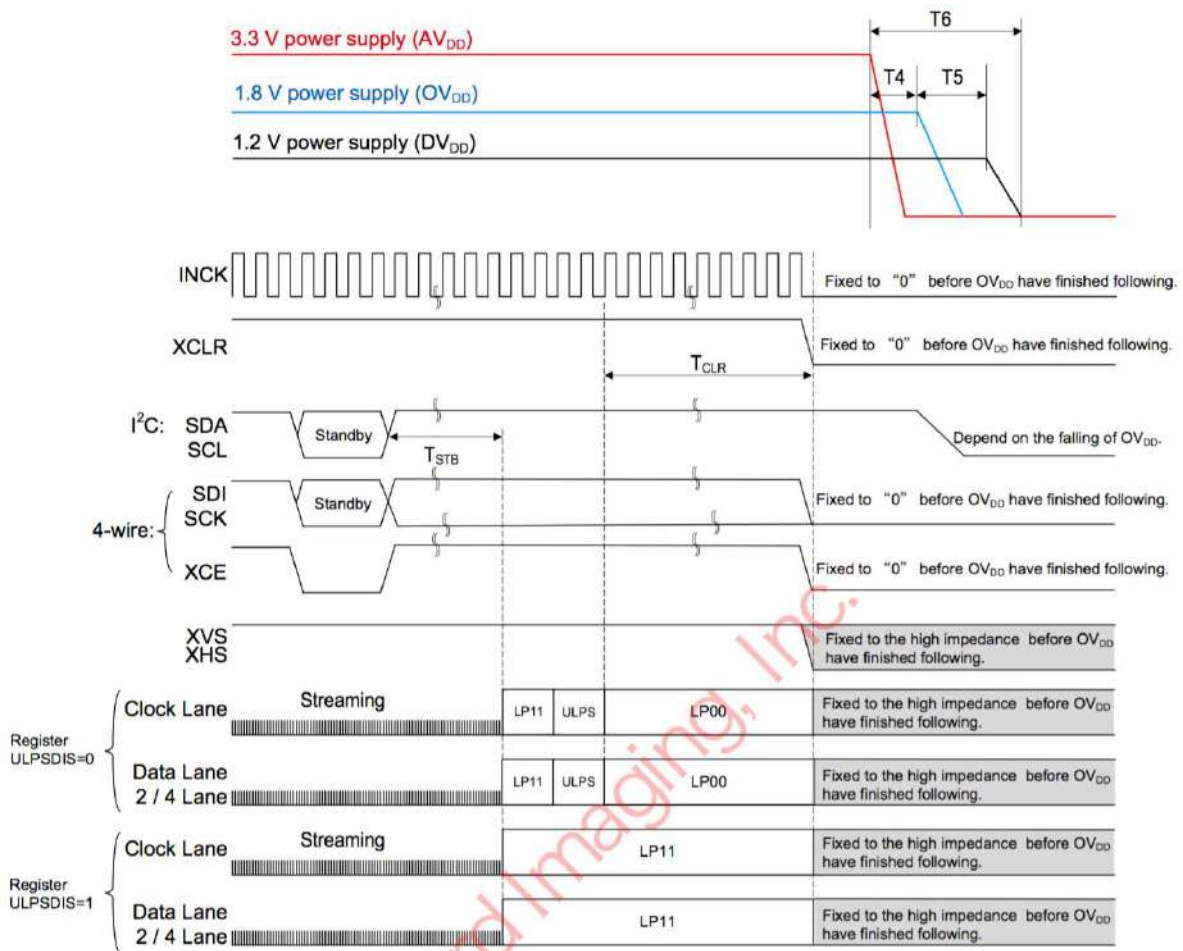

Item	Symbol	Min.	Max.	Unit
Standby ON (communication) → LP11 mode start	T <sub>STB</sub>	Until FE		—
LP00 → XCLR falling (ULPSDIS = 0)	T <sub>CLR</sub>	128	—	cycle
3.3 V power shut down → 1.8 V power shut down	T <sub>4</sub>	0	—	ns
1.8 V power shut down → 1.2 V power shut down	T <sub>5</sub>	0	—	ns
Shut down time of all power supply.	T <sub>6</sub>	—	200	ms



## Optical dimension

◆ Image size (recommended recording pixels)

All-pixel scan : diagonal 8.49mm (type 1/1.9)

1080p-HD : diagonal 8.26mm (type 1/1.9)

◆ Number of recommended recording pixels

All-pixel scan : 1920 (H) × 1200 (V) approx. 2.31 M pixels

1080p-HD : 1920 (H) × 1080 (V) approx. 2.07 M pixels

◆ Unit cell size

3.75 μm (H) × 3.75 μm (V)

◆ Recommended eye relief compensation distance : - 30mm to -∞

Inc



## Данный компонент на территории Российской Федерации

### Вы можете приобрести в компании MosChip.

Для оперативного оформления запроса Вам необходимо перейти по данной ссылке:

<http://moschip.ru/get-element>

Вы можете разместить у нас заказ для любого Вашего проекта, будь то серийное производство или разработка единичного прибора.

В нашем ассортименте представлены ведущие мировые производители активных и пассивных электронных компонентов.

Нашей специализацией является поставка электронной компонентной базы двойного назначения, продукции таких производителей как XILINX, Intel (ex.ALTERA), Vicor, Microchip, Texas Instruments, Analog Devices, Mini-Circuits, Amphenol, Glenair.

Сотрудничество с глобальными дистрибьюторами электронных компонентов, предоставляет возможность заказывать и получать с международных складов практически любой перечень компонентов в оптимальные для Вас сроки.

На всех этапах разработки и производства наши партнеры могут получить квалифицированную поддержку опытных инженеров.

Система менеджмента качества компании отвечает требованиям в соответствии с ГОСТ Р ИСО 9001, ГОСТ РВ 0015-002 и ЭС РД 009

### Офис по работе с юридическими лицами:

105318, г.Москва, ул.Щербаковская д.3, офис 1107, 1118, ДЦ «Щербаковский»

Телефон: +7 495 668-12-70 (многоканальный)

Факс: +7 495 668-12-70 (доб.304)

E-mail: [info@moschip.ru](mailto:info@moschip.ru)

Skype отдела продаж:

moschip.ru

moschip.ru\_4

moschip.ru\_6

moschip.ru\_9