

4

3

2

1

THIS DRAWING IS UNPUBLISHED. RELEASED FOR PUBLICATION
© COPYRIGHT -- By TE CONNECTIVITY ALL RIGHTS RESERVED.

LOC		DIST		REVISIONS			
P	LTR	DESCRIPTION		DATE	DWN	APVD	
	Π	CHANGE THE WIDTH OF THE PIN TERMINAL FROM 0.8MM TO 0.9MM		ECO-14-011875	19-AUG-14	Q.L	B.F

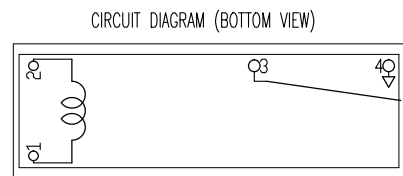
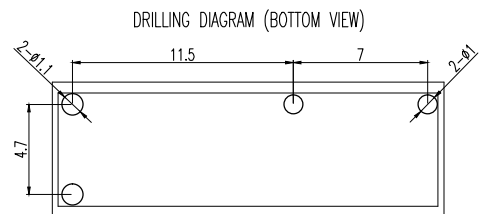
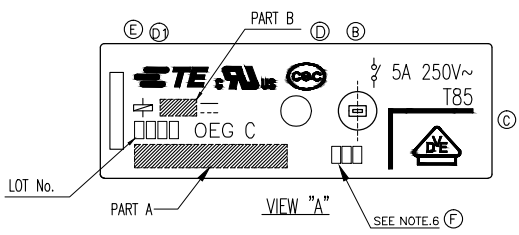
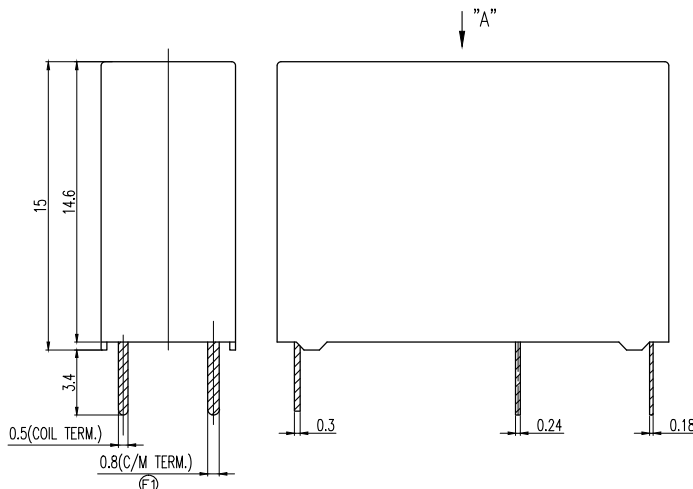

NOTE:
1. LOT NO. SYSTEM AS FOLLOWING;

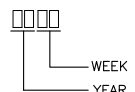

- 2. ONE CHARACTER DISTINGUISH THE LINE IDENTITY, SUCH AS: A, B...
- 3. TERMINAL DIMENSION IS BEFORE SOLDER DIP.
- 4. FOR THE TIN-PLATING OF THE PINS:
+0.1mm FOR WIDTH, THICKNESS AND DIAMETER.
+0.5mm FOR LENGTH.
- 5. MARKING FROM INK CHANGE TO LASER
- 6. ADD LOT NO. SYSTEM AS FOLLOWING;

I II A I. DIGITS FOR DAY OF THE WEEK
I II III 1...MONDAY IN THIS WEEK;
2...TUESDAY IN THIS WEEK;
.....
7...SUNDAY IN THIS WEEK
II. DIGITS FOR SHIFT OF THE DAY
1...DAY SHIFT IN THIS DAY;
2...NIGHT SHIFT IN THIS DAY;
III. ONE CHARACTER DISTINGUISH THE LINE IDENTITY, SUCH AS: A,B.....Z

Diagram dimension	Tolerance
0.99mm max.	±0.1mm
1 - 2.99mm	±0.2mm
3mm min.	±0.3mm

THIS DRAWING IS A CONTROLLED DOCUMENT.

DIMENSIONS:	TOLERANCES UNLESS OTHERWISE SPECIFIED:
mm	0 PLC ± -
	1 PLC ± -
	2 PLC ± -
	3 PLC ± -
	4 PLC ± -
	ANGLES ± -
MATERIAL	FINISH
-	-

DWN	CHK	APVD	NAME
-	-	-	PCJ-WG,000M SPEC
PRODUCT SPEC	APPLICATION SPEC	WEIGHT	RESTRICTED TO
-	-	-	-
SIZE	CAGE CODE	DRAWING NO	REV
A3	00779	C=1721547	F1
CUSTOMER DRAWING		SCALE	SHEET
		5:1	1 OF 2

4

3

2

1

THIS DRAWING IS UNPUBLISHED. RELEASED FOR PUBLICATION
 © COPYRIGHT - By TE CONNECTIVITY ALL RIGHTS RESERVED.

LOC	DIST	REVISIONS			
P	LTR	DESCRIPTION	DATE	DWN	APVD
-	-	SEE SHEET 1	-	-	-

No.	DESCRIPTION	TE PART NO	DESCRIPTION	PART B	PART A
N	PCJ-12403MH-WG, 000M	1-1721547-4	SEAL UP INSPECTION ON EVERY PRODUCT	24V	PCJ-12403MH-WG
M	PCJ-11803MH-WG, 000M	1-1721547-3	SEAL UP INSPECTION ON EVERY PRODUCT	18V	PCJ-11803MH-WG
L	PCJ-11203MH-WG, 000M	1-1721547-2	SEAL UP INSPECTION ON EVERY PRODUCT	12V	PCJ-11203MH-WG
K	PCJ-10803MH-WG, 000M	1-1721547-1	SEAL UP INSPECTION ON EVERY PRODUCT	9V	PCJ-10803MH-WG
J	PCJ-10603MH-WG, 000M	1-1721547-0	SEAL UP INSPECTION ON EVERY PRODUCT	6V	PCJ-10603MH-WG
I	PCJ-10503MH-WG, 000M	1721547-9	SEAL UP INSPECTION ON EVERY PRODUCT	5V	PCJ-10503MH-WG
H	PCJ-10303MH-WG, 000M	1721547-8	SEAL UP INSPECTION ON EVERY PRODUCT	3V	PCJ-10303MH-WG
G	PCJ-12403M-WG, 000M	1721547-7		24V	PCJ-12403M-WG
F	PCJ-11803M-WG, 000M	1721547-6		18V	PCJ-11803M-WG
E	PCJ-11203M-WG, 000M	1721547-5		12V	PCJ-11203M-WG
D	PCJ-10803M-WG, 000M	1721547-4		9V	PCJ-10803M-WG
C	PCJ-10603M-WG, 000M	1721547-3		6V	PCJ-10603M-WG
B	PCJ-10503M-WG, 000M	1721547-2		5V	PCJ-10503M-WG
A	PCJ-10303M-WG, 000M	1721547-1		3V	PCJ-10303M-WG

RELAY TYPE

	Sn-Ag-Cu	SOLDER	18	
94V-0	PA	⊕ CASE	17	
	UV	SEAL(CASE) JUST FOR WASH TIGHT	16	
	EPOXY	SEAL(CASE AND BASE)	15	
	SUEW	MAGNETIC WIRE	14	
94V-0	PBT	CARD	13	
	Ag ALLOY	STATIONARY CONTACT	12	
	Cu ALLOY	STATIONARY TERMINAL	11	
	Ag ALLOY	MOVABLE CONTACT	10	
	Cu ALLOY	MOVABLE SPRING	9	
94V-0	PET	⊕ BASE	8	
	STAINLESS	HINGE SPRING	7	
	NIP	STEEL ARMATURE	6	
	NIP	STEEL CORE	5	
	NIP	STEEL YOKE	4	
	SOLDER DIP	Cu ALLOY COIL TERMINAL B	3	
	SOLDER DIP	Cu ALLOY COIL TERMINAL A	2	
94V-0	PBT	BOBBIN	1	
COMBUSTIBILITY	TREATMENT	MATERIAL	DESCRIPTION	TEM

THIS DRAWING IS A CONTROLLED DOCUMENT.

DIMENSIONS: mm		TOLERANCES UNLESS OTHERWISE SPECIFIED:		DWN	CHK	NAME		RESTRICTED TO
		0 PLC ± - 1 PLC ± - 2 PLC ± - 3 PLC ± - 4 PLC ± - ANGLES ± -		APVD	PRODUCT SPEC	PCJ-WG,000M SPEC		
MATERIAL		FINISH		WEIGHT	APPLICATION SPEC	SIZE	CAGE CODE	DRAWING NO
-		-		-	-	A3	00779	C=1721547
CUSTOMER DRAWING				SCALE	SHEET	REV	F1	
				5:1	2 OF 2			

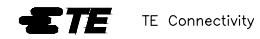

Данный компонент на территории Российской Федерации

Вы можете приобрести в компании MosChip.

Для оперативного оформления запроса Вам необходимо перейти по данной ссылке:

<http://moschip.ru/get-element>

Вы можете разместить у нас заказ для любого Вашего проекта, будь то серийное производство или разработка единичного прибора.

В нашем ассортименте представлены ведущие мировые производители активных и пассивных электронных компонентов.

Нашей специализацией является поставка электронной компонентной базы двойного назначения, продукции таких производителей как XILINX, Intel (ex.ALTERA), Vicor, Microchip, Texas Instruments, Analog Devices, Mini-Circuits, Amphenol, Glenair.

Сотрудничество с глобальными дистрибьюторами электронных компонентов, предоставляет возможность заказывать и получать с международных складов практически любой перечень компонентов в оптимальные для Вас сроки.

На всех этапах разработки и производства наши партнеры могут получить квалифицированную поддержку опытных инженеров.

Система менеджмента качества компании отвечает требованиям в соответствии с ГОСТ Р ИСО 9001, ГОСТ РВ 0015-002 и ЭС РД 009

Офис по работе с юридическими лицами:

105318, г.Москва, ул.Щербаковская д.3, офис 1107, 1118, ДЦ «Щербаковский»

Телефон: +7 495 668-12-70 (многоканальный)

Факс: +7 495 668-12-70 (доб.304)

E-mail: info@moschip.ru

Skype отдела продаж:

moschip.ru

moschip.ru_4

moschip.ru_6

moschip.ru_9