

Common Mode Choke Coil

ACM-0603



RoHS/RoHS II Compliant



1.60 x 0.85 x 1.10mm

FEATURES:

- These low profile design to save PCB space
- Very low DC resistance
- Wide impedance range from 22ohm to 250ohm

APPLICATIONS:

- Elimination of common mode noise in high-speed, differential mode signal transmission applications such as USB 2.0, IEEE1394 and LVDS.

STANDARD SPECIFICATIONS

Abrakon P/N:	ACM-0603
Operating Temperature	-40°C to +85°C
Storage Temperature	-10°C to +40°C, 70% RH max. in tape and reel

Part Number ACM-0603- Impedance Code	Common Mode Impedance @100MHz	DCR	Rated Current	Rated Voltage	Withstanding Voltage	Insulation Resistance
Units	$\Omega \pm 25\%$	Ω (max.)	mA	Vdc	Vdc	M Ω (min.)
ACM-0603-220	22	0.080	500	50	125	10
ACM-0603-450	45	0.110	500	50	125	10
ACM-0603-900	90	0.145	500	50	125	10
ACM-0603-121	120	0.175	500	50	125	10
ACM-0603-181	180	0.210	500	50	125	10
ACM-0603-251	250	0.280	400	50	125	10

Test Conditions

1. Inductance is measured in HP4287A at frequency of 100MHz
2. Rated Current: For 15°C rise in temperature

PART IDENTIFICATION:

ACM-0603- -

Impedance Code
Please refer to the Table

Packaging
T: 2kpcs/reel

ELECTRICAL CHARACTERISTIC CURVES

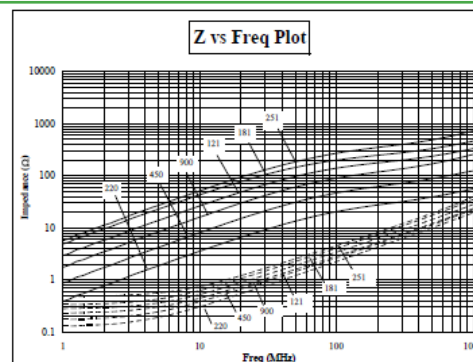

Solid Line: Common Mode
Dotted Line: Differential Mode

ABRACON IS
ISO 9001:2008
CERTIFIED



ABRACON
CORPORATION

Visit www.abracon.com for Terms & Conditions of Sale
30332 Esperanza, Rancho Santa Margarita, California 92688
tel 949-546-8000 | fax 949-546-8001 | www.abracon.com

Revised: 10.14.13

Common Mode Choke Coil

ACM-0603



RoHS/RoHS II Compliant



1.60 x 0.85 x 1.10mm

TEST CIRCUIT:

Parameter	Terminal to be tested
Common Mode Impedance	
Withstanding Voltage	
DC Resistance	
Rated Current	
Insulation Resistance	

OUTLINE DIMENSIONS:

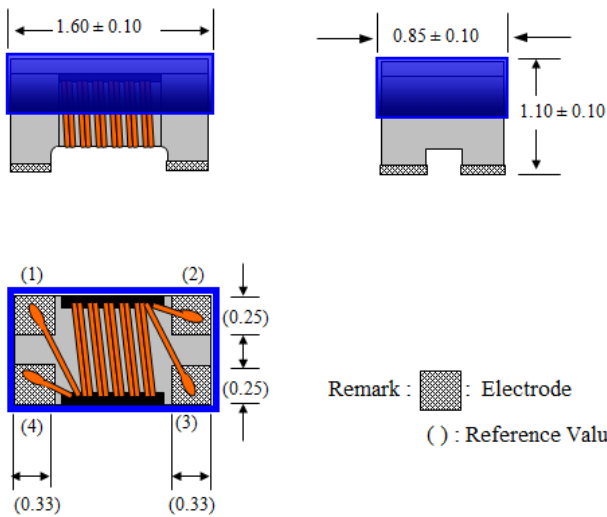

Recommended Land Pattern

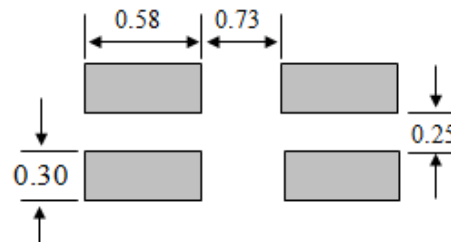

Schematic

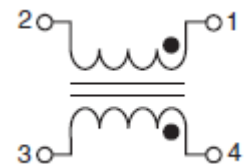

Material Structure

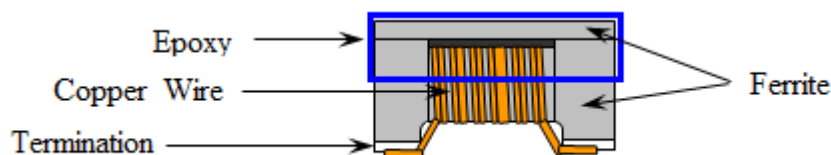

Termination: Ag followed by Nickel, then gold plating.

Common Mode Choke Coil

ACM-0603



RoHS/RoHS II Compliant



1.60 x 0.85 x 1.10mm

REFLOW PROFILE:

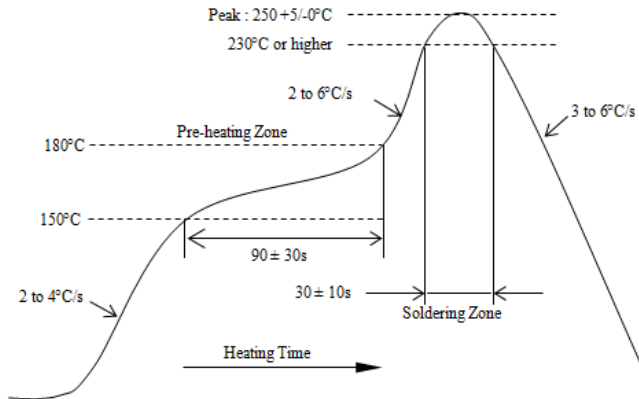

TAPE & REEL:

T= tape and reel (2,000pcs/reel)

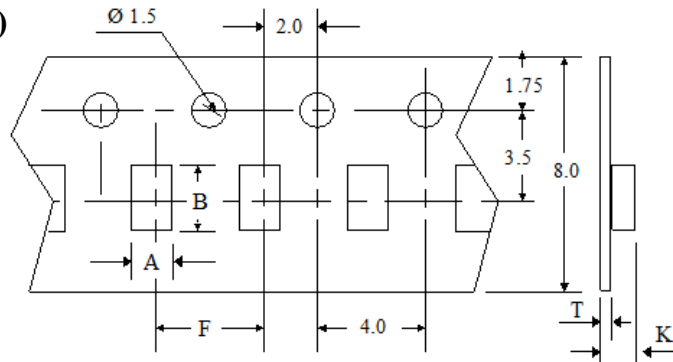

A	B	F	K	T
1.05±0.10	1.85±0.10	4.00±0.10	1.15±0.10	0.23±0.10

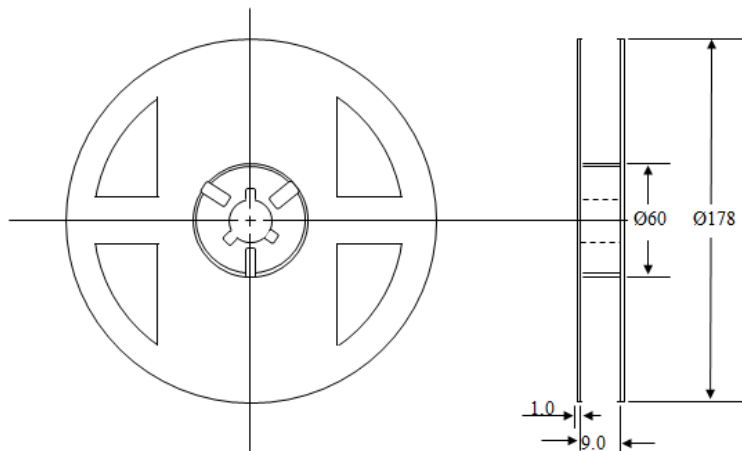

Dimension: mm

ATTENTION: Abracon Corporation's products are COTS – Commercial-Off-The-Shelf products; suitable for Commercial, Industrial and, where designated, Automotive Applications. Abracon's products are not specifically designed for Military, Aviation, Aerospace, Life-dependant Medical applications or any application requiring high reliability where component failure could result in loss of life and/or property. For applications requiring high reliability and/or presenting an extreme operating environment, written consent and authorization from Abracon Corporation is required. Please contact Abracon Corporation for more information.

ABRACON IS
ISO 9001:2008
CERTIFIED



Visit www.abracon.com for Terms & Conditions of Sale **Revised: 10.14.13**
30332 Esperanza, Rancho Santa Margarita, California 92688
tel 949-546-8000 | fax 949-546-8001 | www.abracon.com

Данный компонент на территории Российской Федерации

Вы можете приобрести в компании MosChip.

Для оперативного оформления запроса Вам необходимо перейти по данной ссылке:

<http://moschip.ru/get-element>

Вы можете разместить у нас заказ для любого Вашего проекта, будь то серийное производство или разработка единичного прибора.

В нашем ассортименте представлены ведущие мировые производители активных и пассивных электронных компонентов.

Нашей специализацией является поставка электронной компонентной базы двойного назначения, продукции таких производителей как XILINX, Intel (ex.ALTERA), Vicor, Microchip, Texas Instruments, Analog Devices, Mini-Circuits, Amphenol, Glenair.

Сотрудничество с глобальными дистрибьюторами электронных компонентов, предоставляет возможность заказывать и получать с международных складов практически любой перечень компонентов в оптимальные для Вас сроки.

На всех этапах разработки и производства наши партнеры могут получить квалифицированную поддержку опытных инженеров.

Система менеджмента качества компании отвечает требованиям в соответствии с ГОСТ Р ИСО 9001, ГОСТ РВ 0015-002 и ЭС РД 009

Офис по работе с юридическими лицами:

105318, г.Москва, ул.Щербаковская д.3, офис 1107, 1118, ДЦ «Щербаковский»

Телефон: +7 495 668-12-70 (многоканальный)

Факс: +7 495 668-12-70 (доб.304)

E-mail: info@moschip.ru

Skype отдела продаж:

moschip.ru

moschip.ru_4

moschip.ru_6

moschip.ru_9