

HARDWARE OPTION H
(SOCKET HEAD SCREW)

STANDARD HARDWARE SUPPLIED
(SLOTTED HEAD SCREW)

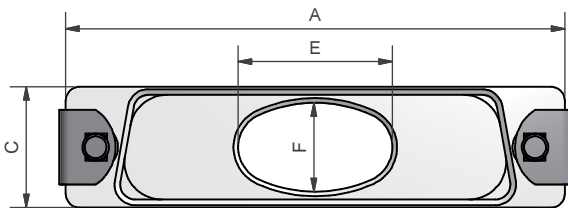

RFI COMB
OPTION

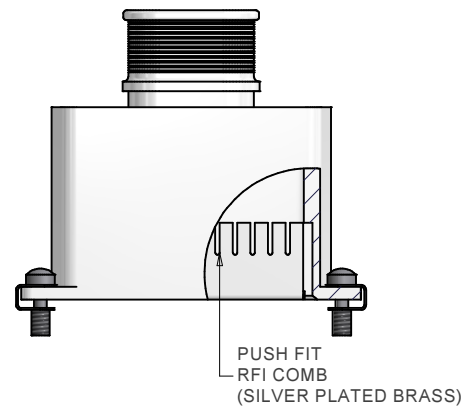

HARDWARE OPTION E
(EXTENDED SCREW)

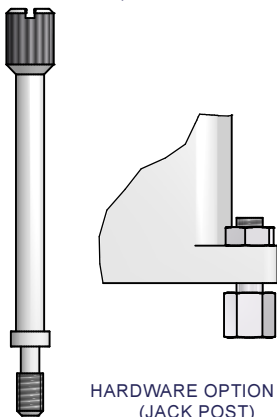

HARDWARE OPTION PF-0
(JACK POST)

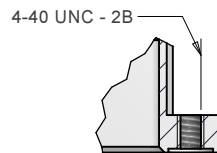

HARDWARE OPTION PF-0
(THREADED HOLES TO
ACCEPT JACK POSTS)

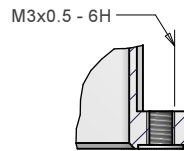

HARDWARE OPTION M3-0
(THREADED HOLES M3)

DRAWN	W.RUST	DATE 21/02/2012	3RD ANGLE PROJECTION NOT TO SCALE	 POLAMCO LTD WESTON LOCK LOWER BRISTOL ROAD BATH BA2 1EP	PAGE 1	UNLESS OTHERWISE SPECIFIED ALL DIMENSIONS IN MILLIMETRES	
SALES APPR					ASSY USED ON: MIL-C-24308	MATERIAL	
DESIGN APPR			THIS DRAWING IS COPYRIGHT AND THE PROPERTY OF POLAMCO LTD IT MUST NOT BE COPIED, USED FOR MANUFACTURE OR OTHERWISE DISCLOSED WITHOUT PRIOR WRITTEN CONSENT OF THE COMPANY.	TITLE:			
QUAL APPR					D-SUB BANDING BACKSHELL		
ISSUE 10	DCR 5821				PART NUMBER:		NCAGE CODE U5792
WEIGHT	GENERAL TOL LINEAR +/-0.1MM ANGULAR +/-1°					DRAWING NO: P10143	
						D**-1-BT**-**-*	

EXAMPLE PART NUMBERING: D25-1-BT-08E-1-C-E-L20	
D =	D-SUBMINIATURE
25 =	SHELL SIZE (SEE TABLE 1)
1 =	ENTRY POSITION (1 - TOP)
BT =	TERMINATION STYLE (BT - BAND TERMINATION STYLE)
08 =	ENTRY SIZE (SEE TABLE 2)
E =	INSERT E FOR ELLIPTICAL ENTRY(ENTRY SIZES 07 AND ABOVE ONLY)(OMIT FOR STANDARD CIRCULAR ENTRY)
1 =	MATERIAL (SEE MATERIAL/PLATING TABLE)
C =	PLATING (SEE MATERIAL/PLATING TABLE)
E =	HARDWARE OPTION (OMIT FOR STANDARD)
L20 =	OPTIONAL LENGTH (1MM INCREMENTS) (OMIT FOR STANDARD LENGTH, STANDARD LENGTH = 30MM)

EXAMPLE PART NUMBERING: D25H-1-BT-08E-1-C-E-L20	
D =	CONNECTOR TYPE
25 =	SHELL SIZE (SEE TABLE 1)
H =	RFI COMB
1 =	ENTRY POSITION (1 - TOP)
BT =	TERMINATION STYLE (BT - BAND TERMINATION STYLE)
08 =	ENTRY SIZE (SEE TABLE 2)
E =	INSERT E FOR ELLIPTICAL ENTRY(ENTRY SIZES 07 AND ABOVE ONLY)(OMIT FOR STANDARD CIRCULAR ENTRY)
1 =	MATERIAL (SEE MATERIAL/PLATING TABLE)
C =	PLATING (SEE MATERIAL/PLATING TABLE)
E =	HARDWARE OPTION (OMIT FOR STANDARD)
L20 =	OPTIONAL LENGTH (1MM INCREMENTS) (OMIT FOR STANDARD LENGTH, STANDARD LENGTH = 30MM)

TABLE 1	SHELL SIZE	MIL SPEC SHELL SIZE REFERENCE	A	B	C	MAX ENTRY (CIRCULAR)	MAX ENTRY (ELLIPTICAL)
	09	1	31,19	25,00	12,93	06	08E
	15	2	39,52	33,33	12,93	06	10E
	25	3	53,42	47,02	12,93	06	12E
	37	4	69,76	63,50	12,93	06	15E
	50	5	67,31	61,12	15,75	08	16E
	104	6	69,70	63,50	17,35	09	18E

TABLE 2A		
ENTRY SIZE (CIRCULAR)	G	H MAX
01	3,18	9,00
02	4,75	9,00
03	6,86	11,30
04	7,37	13,10
05	7,92	13,10
06	10,03	13,63
07	10,67	14,27
08	12,70	16,30
09	14,27	17,90

TABLE 2B	ENTRY SIZE (ELLIPTICAL)	E MIN	F MIN	J	EQUIV. CIRCULAR ENTRY DIAMETER
	07E	13,0	9,5	16,6	(11,1)
	08E	16,5	9,5	20,1	(12,7)
	09E	20,5	9,5	24,1	(14,3)
	10E	24,7	9,5	28,3	(15,9)
	11E	29,4	9,5	33,0	(17,5)
	12E	34,6	9,5	38,2	(19,1)
	13E	40,2	9,5	43,8	(20,6)
	14E	46,2	9,5	49,8	(22,2)
	15E	52,7	9,5	56,3	(23,8)
	16E	50,0	12,0	53,6	(25,4)
	17E	49,2	13,9	52,8	(27,0)
	18E	54,9	13,9	58,5	(28,6)

CODE	MATERIAL / PLATING
1-C	ALUMINIUM / ELECTROLESS NICKEL
1-B	ALUMINIUM / CADMIUM OLIVE DRAB OVER ELECTROLESS NICKEL
1-U	ALUMINIUM / UNPLATED
1-ZB	ALUMINIUM / ZINC COBALT OLIVE DRAB OVER ELECTROLESS NICKEL
1-ZN	ALUMINIUM / ZINC NICKEL BLACK PASSIVATE OVER ELECTROLESS NICKEL
1-Y	ALUMINIUM / YELLOW CHROMATE OVER CADMIUM
4-J	STAINLESS STEEL / PASSIVATE

DRAWN	W.RUST	DATE 21/02/2012	 3RD ANGLE PROJECTION NOT TO SCALE	 POLAMCO LTD WESTON LOCK LOWER BRISTOL ROAD BATH BA2 1EP	PAGE 2	UNLESS OTHERWISE SPECIFIED ALL DIMENSIONS IN MILLIMETRES
SALES APPR						
DESIGN APPR			THIS DRAWING IS COPYRIGHT AND THE PROPERTY OF POLAMCO LTD IT MUST NOT BE COPIED, USED FOR MANUFACTURE OR OTHERWISE DISCLOSED WITHOUT PRIOR WRITTEN CONSENT OF THE COMPANY.	ASSY USED ON: MIL-C-24308		MATERIAL
QUAL APPR				TITLE: D-SUB BANDING BACKSHELL		
ISSUE 10	DCR 5821			PART NUMBER: D**-1-BT-**-**		DRAWING NO: P10143
WEIGHT	GENERAL TOL LINEAR +/-0.1MM ANGULAR +/- 1°					

Данный компонент на территории Российской Федерации

Вы можете приобрести в компании MosChip.

Для оперативного оформления запроса Вам необходимо перейти по данной ссылке:

<http://moschip.ru/get-element>

Вы можете разместить у нас заказ для любого Вашего проекта, будь то серийное производство или разработка единичного прибора.

В нашем ассортименте представлены ведущие мировые производители активных и пассивных электронных компонентов.

Нашей специализацией является поставка электронной компонентной базы двойного назначения, продукции таких производителей как XILINX, Intel (ex.ALTERA), Vicor, Microchip, Texas Instruments, Analog Devices, Mini-Circuits, Amphenol, Glenair.

Сотрудничество с глобальными дистрибьюторами электронных компонентов, предоставляет возможность заказывать и получать с международных складов практически любой перечень компонентов в оптимальные для Вас сроки.

На всех этапах разработки и производства наши партнеры могут получить квалифицированную поддержку опытных инженеров.

Система менеджмента качества компании отвечает требованиям в соответствии с ГОСТ Р ИСО 9001, ГОСТ РВ 0015-002 и ЭС РД 009

Офис по работе с юридическими лицами:

105318, г.Москва, ул.Щербаковская д.3, офис 1107, 1118, ДЦ «Щербаковский»

Телефон: +7 495 668-12-70 (многоканальный)

Факс: +7 495 668-12-70 (доб.304)

E-mail: info@moschip.ru

Skype отдела продаж:

moschip.ru

moschip.ru_4

moschip.ru_6

moschip.ru_9