

## 7/8-Bit Single, +36V ( $\pm 18V$ ) Digital POT with I<sup>2</sup>C™ Serial Interface and Volatile Memory

### Features:

- High-Voltage Analog Support:
  - +36V Terminal Voltage Range (DGND = V-)
  - $\pm 18V$  Terminal Voltage Range (DGND = V- + 18V)
- Wide Operating Voltage:
  - Analog: 10V to 36V (specified performance)
  - Digital: 2.7V to 5.5V  
1.8V to 5.5V ( $V_L \geq V- + 2.7V$ )
- Single-Resistor Network
- Resistor Network Resolution
  - 7-bit: 127 Resistors (128 Taps)
  - 8-bit: 255 Resistors (256 Taps)
- R<sub>AB</sub> Resistance Options:
  - 5 k $\Omega$  – 10 k $\Omega$
  - 50 k $\Omega$  – 100 k $\Omega$
- High Terminal/Wiper Current (I<sub>W</sub>) Support:
  - 25 mA (for 5 k $\Omega$ )
  - 12.5 mA (for 10 k $\Omega$ )
  - 6.5 mA (for 50 k $\Omega$  and 100 k $\Omega$ )
- Zero-Scale to Full-Scale Wiper Operation
- Low Wiper Resistance: 75  $\Omega$  (typical)
- Low Tempco:
  - Absolute (Rheostat): 50 ppm typical (0°C to +70°C)
  - Ratiometric (Potentiometer): 15 ppm typical
- I<sup>2</sup>C Serial Interface:
  - 100 kHz, 400 kHz, 1.7 MHz, and 3.4 MHz support
- Resistor Network Terminal Disconnect Via:
  - Shutdown Pin (SHDN)
  - Terminal Control (TCON) Register
- Write Latch (WLAT) Pin to Control Update of Volatile Wiper Register (such as Zero Crossing)
- Power-On Reset/Brown-Out Reset for Both:
  - Digital supply ( $V_L$ /DGND); 1.5V typical
  - Analog supply (V+/V-); 3.5V typical
- Serial Interface Inactive Current (3  $\mu$ A typical)
- 500 kHz Typical Bandwidth (-4 dB) Operation (5.0 k $\Omega$  Device)
- Extended Temperature Range (-40°C to +125°C)
- Package Types: TSSOP-14 and QFN-20 (5x5)

### Package Types (Top View)



### Description:

The MCP45HVX1 family of devices have dual power rails (analog and digital). The analog power rail allows high voltage on the resistor network terminal pins. The analog voltage range is determined by the V+ and V- voltages. The maximum analog voltage is +36V, while the operating analog output minimum specifications are specified from either 10V or 20V. As the analog supply voltage becomes smaller, the analog switch resistances increase, which affect certain performance specifications. The system can be implemented as dual rail ( $\pm 18V$ ) relative to the digital logic ground (DGND).

The device also has a Write Latch (WLAT) function, which will inhibit the volatile Wiper register from being updated (latched) with the received data, until the WLAT pin is Low. This allows the application to specify a condition where the volatile Wiper register is updated (such as zero crossing).

# MCP45HVX1

## Device Block Diagram



## Device Features

Device	# of POTS	Wiper Configuration	Control Interface	POR Wiper Setting	Resistance (Typical)		Number of:		Specified Operating Range	
					R <sub>AB</sub> Options (k $\Omega$ )	Wiper-R <sub>W</sub> ( $\Omega$ )	R <sub>S</sub>	Taps	V <sub>L</sub> <sup>(2)</sup>	V <sub>+</sub> <sup>(3)</sup>
MCP45HV31	1	Potentiometer <sup>(1)</sup>	I <sup>2</sup> C <sup>TM</sup>	3Fh	5.0, 10.0, 50.0, 100.0	75	127	128	1.8V to 5.5V	10V <sup>(4)</sup> to 36V
MCP45HV51	1	Potentiometer <sup>(1)</sup>	I <sup>2</sup> C	7Fh	5.0, 10.0, 50.0, 100.0	75	255	256	1.8V to 5.5V	10V <sup>(4)</sup> to 36V
MCP41HV31 <sup>(5)</sup>	1	Potentiometer	SPI	3Fh	5.0, 10.0, 50.0, 100.0	75	127	128	1.8V to 5.5V	10V <sup>(4)</sup> to 36V
MCP41HV51 <sup>(5)</sup>	1	Potentiometer <sup>(5)</sup>	SPI	7Fh	5.0, 10.0, 50.0, 100.0	75	255	256	1.8V to 5.5V	10V <sup>(4)</sup> to 36V

- Note 1:** Floating either terminal (A or B) allows the device to be used as a Rheostat (variable resistor).
- Note 2:** This is relative to the DGND signal. There is a separate requirement for the V<sub>+</sub>/V<sub>-</sub> voltages.  
V<sub>L</sub> ≥ V<sub>-</sub> + 2.7V.
- Note 3:** Relative to V<sub>-</sub>, the V<sub>L</sub> and DGND signals must be between (inclusive) V<sub>-</sub> and V<sub>+</sub>.
- Note 4:** Analog operation will continue while the V<sub>+</sub> voltage is above the device's analog Power-On Reset (POR)/Brown-out Reset (BOR) voltage. Operational characteristics may exceed specified limits while the V<sub>+</sub> voltage is below the specified minimum voltage.
- Note 5:** For additional information on these devices, refer to DS20005207.

## 1.0 ELECTRICAL CHARACTERISTICS

### Absolute Maximum Ratings †

Voltage on V- with respect to DGND .....	DGND + 0.6V to -40.0V
Voltage on V+ with respect to DGND .....	DGND - 0.3V to 40.0V
Voltage on V+ with respect to V- .....	DGND - 0.3V to 40.0V
Voltage on V <sub>L</sub> with respect to V+ .....	-0.6V to -40.0V
Voltage on V <sub>L</sub> with respect to V- .....	-0.6V to +40.0V
Voltage on V <sub>L</sub> with respect to DGND .....	-0.6V to +7.0V
Voltage on SCL, SDA, A0, A1, $\overline{\text{WLA}}\overline{\text{T}}$ , and $\overline{\text{SHDN}}$ with respect to DGND .....	-0.6V to V <sub>L</sub> + 0.6V
Voltage on all other pins (PxA, PxW, and PxB) with respect to V- .....	-0.3V to V+ + 0.3V
Input clamp current, I <sub>IK</sub> (V <sub>I</sub> < 0, V <sub>I</sub> > V <sub>L</sub> , V <sub>I</sub> > V <sub>PP</sub> on HV pins) .....	±20 mA
Output clamp current, I <sub>OK</sub> (V <sub>O</sub> < 0 or V <sub>O</sub> > V <sub>L</sub> ) .....	±20 mA
Maximum current out of DGND pin .....	100 mA
Maximum current into V <sub>L</sub> pin .....	100 mA
Maximum current out of V- pin .....	100 mA
Maximum current into V+ pin .....	100 mA
Maximum current into PxA, PxW, and PxB pins (Continuous)	
R <sub>AB</sub> = 5 kΩ .....	±25 mA
R <sub>AB</sub> = 10 kΩ .....	±12.5 mA
R <sub>AB</sub> = 50 kΩ .....	±6.5 mA
R <sub>AB</sub> = 100 kΩ .....	±6.5 mA
Maximum current into PxA, PxW, and PxB pins (Pulsed)	
F <sub>PULSE</sub> > 10 kHz .....	(Max I <sub>Continuous</sub> ) / (Duty Cycle)
F <sub>PULSE</sub> ≤ 10 kHz .....	(Max I <sub>Continuous</sub> ) / √(Duty Cycle)
Maximum output current sunk by any Output pin .....	25 mA
Maximum output current sourced by any Output pin .....	25 mA
Package Power Dissipation (T <sub>A</sub> = + 50°C, T <sub>J</sub> = +150°C)	
TSSOP-14 .....	1000 mW
QFN-20 (5 x 5) .....	2800 mW
Soldering temperature of leads (10 seconds) .....	+300°C
ESD protection on all pins	
Human Body Model (HBM) .....	≥ ±5 kV
Machine Model (MM) .....	≥ ±400V
Maximum Junction Temperature (T <sub>J</sub> ) .....	150°C
Storage temperature .....	-65°C to +150°C
Ambient temperature with power applied .....	-40°C to +125°C

† **Notice:** Stresses above those listed under “Maximum Ratings” may cause permanent damage to the device. This is a stress rating only and functional operation of the device at those or any other conditions above those indicated in the operational listings of this specification is not implied. Exposure to maximum rating conditions for extended periods may affect device reliability.

# MCP45HVX1

## AC/DC CHARACTERISTICS

DC Characteristics		Standard Operating Conditions (unless otherwise specified)				
		Operating Temperature $-40^{\circ}\text{C} \leq T_A \leq +125^{\circ}\text{C}$ (extended)				
		All parameters apply across the specified operating ranges unless noted.				
		$V_+ = 10\text{V to } 36\text{V}$ (referenced to $V_-$ );				
		$V_+ = +5\text{V to } +18\text{V}$ and $V_- = -5.0\text{V to } -18\text{V}$ (referenced to DGND $\rightarrow \pm 5\text{V to } \pm 18\text{V}$ ),				
		$V_L = +2.7\text{V to } 5.5\text{V}$ , 5 k $\Omega$ , 10 k $\Omega$ , 50 k $\Omega$ , 100 k $\Omega$ devices.				
		Typical specifications represent values for $V_L = 5.5\text{V}$ , $T_A = +25^{\circ}\text{C}$ .				
Parameters	Sym.	Min.	Typ.	Max.	Units	Conditions
Digital Positive Supply Voltage ( $V_L$ )	$V_L$	2.7	—	5.5	V	With respect to DGND ( <b>Note 4</b> )
		1.8	—	5.5	V	$V_L \geq V_- + 2.7\text{V}$ ( <b>Note 1</b> , <b>Note 4</b> )
		—	—	0	V	With respect to $V_+$
Analog Positive Supply Voltage ( $V_+$ )	$V_+$	$V_L^{(16)}$	—	36.0	V	With respect to $V_-$ ( <b>Note 4</b> )
Digital Ground Voltage (DGND)	$V_{\text{DGND}}$	$V_-$	—	$V_+ - V_L$	V	With respect to $V_-$ ( <b>Note 4</b> , <b>Note 5</b> )
Analog Negative Supply Voltage ( $V_-$ )	$V_-$	$-36.0 + V_L$	—	0	V	With respect to DGND and with $V_L = 1.8\text{V}$
Resistor Network Supply Voltage	$V_{\text{RN}}$	—	—	36.0	V	Delta voltage between $V_+$ and $V_-$ ( <b>Note 4</b> )
$V_L$ Start Voltage to ensure Wiper Reset	$V_{\text{DPOR}}$	—	—	1.8	V	With respect to DGND, $V_+ > 6.0\text{V}$ RAM retention voltage ( $V_{\text{RAM}} < V_{\text{DBOR}}$ )
$V_+$ Voltage to ensure Wiper Reset	$V_{\text{APOR}}$	—	—	6.0	V	With respect to $V_-$ , $V_L = 0\text{V}$ RAM retention voltage ( $V_{\text{RAM}} < V_{\text{BOR}}$ )
Digital to Analog Level Shifter Operational Voltage	$V_{\text{LS}}$	—	—	2.3	V	$V_L$ to $V_-$ voltage. DGND = $V_-$
Power Rail Voltages during Power-Up ( <b>Note 1</b> )	$V_{\text{LPOR}}$	—	—	5.5	V	Digital Powers ( $V_L/\text{DGND}$ ) up 1st: $V_+$ and $V_-$ floating or as $V_+/V_-$ powers-up ( $V_+$ must be $\geq$ to DGND) ( <b>Note 18</b> )
	$V_{\text{+POR}}$	—	—	36	V	Analog Powers ( $V_+/V_-$ ) up 1st: $V_L$ and DGND floating or as $V_L/\text{DGND}$ powers-up (DGND must be between $V_-$ and $V_+$ ) ( <b>Note 18</b> )
$V_L$ Rise Rate to ensure Power-On Reset	$V_{\text{LRR}}$	<b>(Note 6)</b>			V/ms	With respect to DGND

**Note 1:** This specification by design.

**Note 4:**  $V_+$  voltage is dependent on  $V_-$  voltage. The maximum delta voltage between  $V_+$  and  $V_-$  is 36V. The digital logic DGND potential can be anywhere between  $V_+$  and  $V_-$ , the  $V_L$  potential must be  $\geq$  DGND and  $\leq V_+$ .

**Note 5:** Minimum value determined by maximum  $V_-$  to  $V_+$  potential equals 36V and minimum  $V_L = 1.8\text{V}$  for operation. So  $36\text{V} - 1.8\text{V} = 34.2\text{V}$ .

**Note 6:** POR/BOR is not rate dependent.

**Note 16:** For specified analog performance,  $V_+$  must be 20V or greater (unless otherwise noted).

**Note 18:** During the power-up sequence, to ensure expected analog POR operation, the two power systems (analog and digital) should have a common reference to ensure that the driven DGND voltage is not at a higher potential than the driven  $V_+$  voltage.

## AC/DC CHARACTERISTICS (CONTINUED)

DC Characteristics		Standard Operating Conditions (unless otherwise specified) Operating Temperature $-40^{\circ}\text{C} \leq T_A \leq +125^{\circ}\text{C}$ (extended) All parameters apply across the specified operating ranges unless noted. $V_+ = 10\text{V}$ to $36\text{V}$ (referenced to $V_-$ ); $V_+ = +5\text{V}$ to $+18\text{V}$ and $V_- = -5.0\text{V}$ to $-18\text{V}$ (referenced to DGND $\rightarrow \pm 5\text{V}$ to $\pm 18\text{V}$ ), $V_L = +2.7\text{V}$ to $5.5\text{V}$ , $5\text{ k}\Omega$ , $10\text{ k}\Omega$ , $50\text{ k}\Omega$ , $100\text{ k}\Omega$ devices. Typical specifications represent values for $V_L = 5.5\text{V}$ , $T_A = +25^{\circ}\text{C}$ .					
Parameters	Sym.	Min.	Typ.	Max.	Units	Conditions	
Delay after device exits the Reset state ( $V_L > V_{BOR}$ )	$T_{BORD}$	—	10	20	$\mu\text{s}$		
Supply Current (Note 7)	$I_{DDD}$	—	45	650	$\mu\text{A}$	Serial Interface Active, Write all 0's to Volatile Wiper 0 (address 0h) $V_L = 5.5\text{V}$ , $F_{SCL} = 3.4\text{ MHz}$ , $V_- = \text{DGND}$	
		—	4	7	$\mu\text{A}$	Serial Interface Inactive, $V_L = 5.5\text{V}$ , $SCL = V_{IH}$ , Wiper = 0, $V_- = \text{DGND}$	
	$I_{DDA}$	—	—	5	$\mu\text{A}$	Current $V_+$ to $V_-$ , $PxA = PxB = PxB$ , $\text{DGND} = V_- + (V_+/2)$	
Resistance ( $\pm 20\%$ ) (Note 8)	$R_{AB}$	4.0	5	6.0	$\text{k}\Omega$	-502 devices, $V_+/V_- = 10\text{V}$ to $36\text{V}$	
		8.0	10	12.0	$\text{k}\Omega$	-103 devices, $V_+/V_- = 10\text{V}$ to $36\text{V}$	
		40.0	50	60.0	$\text{k}\Omega$	-503 devices, $V_+/V_- = 10\text{V}$ to $36\text{V}$	
		80.0	100	120.0	$\text{k}\Omega$	-104 devices, $V_+/V_- = 10\text{V}$ to $36\text{V}$	
$R_{AB}$ Current	$I_{AB}$	—	—	9.00	$\text{mA}$	-502 devices	
		—	—	4.50	$\text{mA}$	-103 devices	
		—	—	0.90	$\text{mA}$	-503 devices	
		—	—	0.45	$\text{mA}$	-104 devices	
Resolution	N	256			Taps	8-bit	No Missing Codes
		128			Taps	7-bit	No Missing Codes
Step Resistance (see Appendix B.4)	$R_S$	—	$R_{AB}/(255)$	—	$\Omega$	8-bit	Note 1
		—	$R_{AB}/(127)$	—	$\Omega$	7-bit	Note 1

Note 1: This specification by design.

Note 7: Supply current ( $I_{DDD}$  and  $I_{DDA}$ ) is independent of current through the resistor network.

Note 8: Resistance ( $R_{AB}$ ) is defined as the resistance between Terminal A to Terminal B.

Note 9: Ensured by the  $R_{AB}$  specification and Ohm's Law.

# MCP45HVX1

## AC/DC CHARACTERISTICS (CONTINUED)

DC Characteristics		Standard Operating Conditions (unless otherwise specified) Operating Temperature $-40^{\circ}\text{C} \leq T_A \leq +125^{\circ}\text{C}$ (extended) All parameters apply across the specified operating ranges unless noted. $V_+ = 10\text{V}$ to $36\text{V}$ (referenced to $V_-$ ); $V_+ = +5\text{V}$ to $+18\text{V}$ and $V_- = -5.0\text{V}$ to $-18\text{V}$ (referenced to DGND $\rightarrow \pm 5\text{V}$ to $\pm 18\text{V}$ ), $V_L = +2.7\text{V}$ to $5.5\text{V}$ , $5\text{ k}\Omega$ , $10\text{ k}\Omega$ , $50\text{ k}\Omega$ , $100\text{ k}\Omega$ devices. Typical specifications represent values for $V_L = 5.5\text{V}$ , $T_A = +25^{\circ}\text{C}$ .					
Parameters	Sym.	Min.	Typ.	Max.	Units	Conditions	
Wiper Resistance (see <a href="#">Appendix B.5</a> )	$R_W$	—	75	170	$\Omega$	$I_W = 1\text{ mA}$	$V_+ = +18\text{V}$ , $V_- = -18\text{V}$ , code = 00h, PxA = floating, PxB = $V_-$ .
		—	145	200	$\Omega$	$I_W = 1\text{ mA}$	$V_+ = +5.0\text{V}$ , $V_- = -5.0\text{V}$ , code = 00h, PxA = floating, PxB = $V_-$ . ( <a href="#">Note 2</a> )
Nominal Resistance Tempco (see <a href="#">Appendix B.23</a> )	$\Delta R_{AB}/\Delta T$	—	50	—	ppm/ $^{\circ}\text{C}$	$T_A = -40^{\circ}\text{C}$ to $+85^{\circ}\text{C}$	
		—	100	—	ppm/ $^{\circ}\text{C}$	$T_A = -40^{\circ}\text{C}$ to $+125^{\circ}\text{C}$	
Ratiometric Tempco (see <a href="#">Appendix B.22</a> )	$\Delta V_{BW}/\Delta T$	—	15	—	ppm/ $^{\circ}\text{C}$	Code = Mid scale (7Fh or 3Fh)	
Resistor Terminal Input Voltage Range (Terminals A, B and W)	$V_A, V_W, V_B$	$V_-$	—	$V_+$	V	<a href="#">Note 1</a> , <a href="#">Note 11</a>	
Current through Terminals (A, B, and Wiper) ( <a href="#">Note 1</a> )	$I_T, I_W$	—	—	25	mA	-502 devices	$I_{BW(W \neq ZS)}$ and $I_{AW(W \neq FS)}$
		—	—	12.5	mA	-103 devices	$I_{BW(W \neq ZS)}$ and $I_{AW(W \neq FS)}$
		—	—	6.5	mA	-503 devices	$I_{BW(W \neq ZS)}$ and $I_{AW(W \neq FS)}$
		—	—	6.5	mA	-104 devices	$I_{BW(W \neq ZS)}$ and $I_{AW(W \neq FS)}$
		—	—	36	mA	$I_{BW(W = ZS)}$ , or $I_{AW(W = FS)}$	
Leakage current into A, W or B	$I_{TL}$	—	5	—	nA	A = W = B = $V_-$	

[Note 1](#): This specification by design.

[Note 2](#): This parameter is not tested, but specified by characterization.

[Note 11](#): Resistor terminals A, W and B's polarity with respect to each other is not restricted.

## AC/DC CHARACTERISTICS (CONTINUED)

DC Characteristics		Standard Operating Conditions (unless otherwise specified)							
		Operating Temperature $-40^{\circ}\text{C} \leq T_A \leq +125^{\circ}\text{C}$ (extended)							
		All parameters apply across the specified operating ranges unless noted.							
		$V_+ = 10\text{V to }36\text{V}$ (referenced to $V_-$ );							
		$V_+ = +5\text{V to }+18\text{V}$ and $V_- = -5.0\text{V to }-18\text{V}$ (referenced to DGND $\rightarrow \pm 5\text{V to } \pm 18\text{V}$ ),							
		$V_L = +2.7\text{V to }5.5\text{V}$ , 5 k $\Omega$ , 10 k $\Omega$ , 50 k $\Omega$ , 100 k $\Omega$ devices.							
		Typical specifications represent values for $V_L = 5.5\text{V}$ , $T_A = +25^{\circ}\text{C}$ .							
Parameters	Sym.	Min.	Typ.	Max.	Units	Conditions			
Full Scale Error (Potentiometer) (8-bit code = FFh, 7-bit code = 7Fh) (Note 10, Note 17) ( $V_A = V_+$ , $V_B = V_-$ ) (see Appendix B.10)	$V_{WFSE}$	-10.5	—	—	LSb	5 k $\Omega$	8-bit	$V_{AB} = 20\text{V to }36\text{V}$	
		-8.5	—	—	LSb			$V_{AB} = 20\text{V to }36\text{V}$ $-40^{\circ}\text{C} \leq T_A \leq +85^{\circ}\text{C}$ (Note 2)	
		-14.0	—	—	LSb			$V_{AB} = 10\text{V to }36\text{V}$	
		-5.5	—	—	LSb			$V_{AB} = 20\text{V to }36\text{V}$	
		-4.5	—	—	LSb	10 k $\Omega$	7-bit	$V_{AB} = 20\text{V to }36\text{V}$ $-40^{\circ}\text{C} \leq T_A \leq +85^{\circ}\text{C}$ (Note 2)	
		-7.5	—	—	LSb			$V_{AB} = 10\text{V to }36\text{V}$	
		-4.5	—	—	LSb			$V_{AB} = 20\text{V to }36\text{V}$	
		-6.0	—	—	LSb			$V_{AB} = 10\text{V to }36\text{V}$	
		-2.65	—	—	LSb	50 k $\Omega$	8-bit	$V_{AB} = 20\text{V to }36\text{V}$	
		-2.25	—	—	LSb			$V_{AB} = 10\text{V to }36\text{V}$	
		-3.5	—	—	LSb			$V_{AB} = 20\text{V to }36\text{V}$ $-40^{\circ}\text{C} \leq T_A \leq +85^{\circ}\text{C}$ (Note 2)	
		-1.0	—	—	LSb			$V_{AB} = 10\text{V to }36\text{V}$	
		-1.4	—	—	LSb	100 k $\Omega$	7-bit	$V_{AB} = 20\text{V to }36\text{V}$	
		-1.0	—	—	LSb			$V_{AB} = 10\text{V to }36\text{V}$	
		-1.2	—	—	LSb			$V_{AB} = 20\text{V to }36\text{V}$	
		-0.7	—	—	LSb			$V_{AB} = 10\text{V to }36\text{V}$	
-0.95	—	—	LSb		8-bit	$V_{AB} = 20\text{V to }36\text{V}$			
-0.85	—	—	LSb			$V_{AB} = 10\text{V to }36\text{V}$			
-0.975	—	—	LSb			$V_{AB} = 20\text{V to }36\text{V}$			
-0.975	—	—	LSb			$V_{AB} = 10\text{V to }36\text{V}$			

**Note 2:** This parameter is not tested, but specified by characterization.

**Note 10:** Measured at  $V_W$  with  $V_A = V_+$  and  $V_B = V_-$ .

**Note 17:** Analog switch leakage affects this specification. Higher temperatures increase the switch leakage.

# MCP45HVX1

## AC/DC CHARACTERISTICS (CONTINUED)

DC Characteristics		Standard Operating Conditions (unless otherwise specified)							
		Operating Temperature $-40^{\circ}\text{C} \leq T_A \leq +125^{\circ}\text{C}$ (extended)							
		All parameters apply across the specified operating ranges unless noted.							
		$V_+ = 10\text{V to } 36\text{V}$ (referenced to $V_-$ );							
		$V_+ = +5\text{V to } +18\text{V}$ and $V_- = -5.0\text{V to } -18\text{V}$ (referenced to DGND $\rightarrow \pm 5\text{V to } \pm 18\text{V}$ ),							
		$V_L = +2.7\text{V to } 5.5\text{V}$ , 5 k $\Omega$ , 10 k $\Omega$ , 50 k $\Omega$ , 100 k $\Omega$ devices.							
		Typical specifications represent values for $V_L = 5.5\text{V}$ , $T_A = +25^{\circ}\text{C}$ .							
Parameters	Sym.	Min.	Typ.	Max.	Units	Conditions			
Zero Scale Error (Potentiometer) (8-bit code = 00h, 7-bit code = 00h) (Note 10, Note 17) ( $V_A = V_+$ , $V_B = V_-$ ) (see Appendix B.11)	$V_{WZSE}$	—	—	+9.5	LSb	5 k $\Omega$	8-bit	$V_{AB} = 20\text{V to } 36\text{V}$	
		—	—	+8.5	LSb			$V_{AB} = 20\text{V to } 36\text{V}$ $-40^{\circ}\text{C} \leq T_A \leq +85^{\circ}\text{C}$ (Note 2)	
		—	—	+14.5	LSb			$V_{AB} = 10\text{V to } 36\text{V}$	
		—	—	+4.5	LSb			$V_{AB} = 20\text{V to } 36\text{V}$	
		—	—	+7.0	LSb	10 k $\Omega$	7-bit	$V_{AB} = 10\text{V to } 36\text{V}$	
		—	—	+4.25	LSb			$V_{AB} = 20\text{V to } 36\text{V}$	
		—	—	+6.5	LSb	8-bit	$V_{AB} = 20\text{V to } 36\text{V}$		
		—	—	+2.125	LSb		$V_{AB} = 10\text{V to } 36\text{V}$		
		—	—	+3.25	LSb	7-bit	$V_{AB} = 20\text{V to } 36\text{V}$		
		—	—	+0.9	LSb		$V_{AB} = 10\text{V to } 36\text{V}$		
		—	—	+1.3	LSb	50 k $\Omega$	8-bit	$V_{AB} = 20\text{V to } 36\text{V}$	
		—	—	+0.5	LSb			$V_{AB} = 10\text{V to } 36\text{V}$	
		—	—	+0.7	LSb	7-bit	$V_{AB} = 20\text{V to } 36\text{V}$		
		—	—	+0.6	LSb		$V_{AB} = 10\text{V to } 36\text{V}$		
		—	—	+0.95	LSb	100 k $\Omega$	8-bit	$V_{AB} = 20\text{V to } 36\text{V}$	
		—	—	+0.3	LSb			$V_{AB} = 10\text{V to } 36\text{V}$	
—	—	+0.475	LSb	7-bit	$V_{AB} = 20\text{V to } 36\text{V}$				
—	—				$V_{AB} = 10\text{V to } 36\text{V}$				

Note 2: This parameter is not tested, but specified by characterization.

Note 10: Measured at  $V_W$  with  $V_A = V_+$  and  $V_B = V_-$ .

Note 17: Analog switch leakage affects this specification. Higher temperatures increase the switch leakage.



## AC/DC CHARACTERISTICS (CONTINUED)

DC Characteristics		Standard Operating Conditions (unless otherwise specified)						
		Operating Temperature $-40^{\circ}\text{C} \leq T_A \leq +125^{\circ}\text{C}$ (extended)						
		All parameters apply across the specified operating ranges unless noted.						
		$V_+ = 10\text{V to } 36\text{V}$ (referenced to $V_-$ );						
		$V_+ = +5\text{V to } +18\text{V}$ and $V_- = -5.0\text{V to } -18\text{V}$ (referenced to DGND $\rightarrow \pm 5\text{V to } \pm 18\text{V}$ ),						
		$V_L = +2.7\text{V to } 5.5\text{V}$ , 5 k $\Omega$ , 10 k $\Omega$ , 50 k $\Omega$ , 100 k $\Omega$ devices.						
		Typical specifications represent values for $V_L = 5.5\text{V}$ , $T_A = +25^{\circ}\text{C}$ .						
Parameters	Sym.	Min.	Typ.	Max.	Units	Conditions		
Potentiometer Integral Nonlinearity ( <b>Note 10</b> , <b>Note 17</b> ) (see <b>Appendix B.12</b> )	P-INL	-1	$\pm 0.5$	+1	LSb	5 k $\Omega$	8-bit	$V_{AB} = 10\text{V to } 36\text{V}$
		-0.5	$\pm 0.25$	+0.5	LSb		7-bit	$V_{AB} = 10\text{V to } 36\text{V}$
		-1	$\pm 0.5$	+1	LSb	10 k $\Omega$	8-bit	$V_{AB} = 10\text{V to } 36\text{V}$
		-0.5	$\pm 0.25$	+0.5	LSb		7-bit	$V_{AB} = 10\text{V to } 36\text{V}$
		-1.1	$\pm 0.5$	+1.1	LSb	50 k $\Omega$	8-bit	$V_{AB} = 10\text{V to } 36\text{V}$
		-1	$\pm 0.5$	+1	LSb			$V_{AB} = 20\text{V to } 36\text{V}$ , ( <b>Note 2</b> )
		-1	$\pm 0.5$	+1	LSb			$V_{AB} = 10\text{V to } 36\text{V}$ , $-40^{\circ}\text{C} \leq T_A \leq +85^{\circ}\text{C}$ ( <b>Note 2</b> )
		-0.6	$\pm 0.25$	+0.6	LSb			7-bit
		-1.85	$\pm 0.5$	+1.85	LSb	100 k $\Omega$	8-bit	$V_{AB} = 10\text{V to } 36\text{V}$
		-1.2	$\pm 0.5$	+1.2	LSb			$V_{AB} = 20\text{V to } 36\text{V}$ , ( <b>Note 2</b> )
		-1	$\pm 0.5$	+1	LSb			$V_{AB} = 10\text{V to } 36\text{V}$ , $-40^{\circ}\text{C} \leq T_A \leq +85^{\circ}\text{C}$ ( <b>Note 2</b> )
		-1	$\pm 0.5$	+1	LSb			7-bit
Potentiometer Differential Nonlinearity ( <b>Note 10</b> , <b>Note 17</b> ) (see <b>Appendix B.13</b> )	P-DNL	-0.7	$\pm 0.25$	+0.7	LSb	5 k $\Omega$	8-bit	$V_{AB} = 10\text{V to } 36\text{V}$
		-0.5	$\pm 0.25$	+0.5	LSb			$V_{AB} = 20\text{V to } 36\text{V}$ ( <b>Note 2</b> )
		-0.25	$\pm 0.125$	+0.25	LSb	10 k $\Omega$	7-bit	$V_{AB} = 10\text{V to } 36\text{V}$
		-0.375	$\pm 0.125$	+0.375	LSb		8-bit	$V_{AB} = 10\text{V to } 36\text{V}$
		-0.25	$\pm 0.1$	+0.25	LSb	50 k $\Omega$	7-bit	$V_{AB} = 10\text{V to } 36\text{V}$
		-0.25	$\pm 0.125$	+0.25	LSb		8-bit	$V_{AB} = 10\text{V to } 36\text{V}$
		-0.125	$\pm 0.1$	+0.125	LSb	100 k $\Omega$	7-bit	$V_{AB} = 10\text{V to } 36\text{V}$
		-0.25	$\pm 0.125$	+0.25	LSb		8-bit	$V_{AB} = 10\text{V to } 36\text{V}$
-0.125	$\pm 0.1$	+0.125	LSb		7-bit	$V_{AB} = 10\text{V to } 36\text{V}$		

**Note 2:** This parameter is not tested, but specified by characterization.

**Note 10:** Measured at  $V_W$  with  $V_A = V_+$  and  $V_B = V_-$ .

**Note 17:** Analog switch leakage affects this specification. Higher temperatures increase the switch leakage.

# MCP45HVX1

## AC/DC CHARACTERISTICS (CONTINUED)

DC Characteristics		Standard Operating Conditions (unless otherwise specified) Operating Temperature $-40^{\circ}\text{C} \leq T_A \leq +125^{\circ}\text{C}$ (extended) All parameters apply across the specified operating ranges unless noted. $V_+ = 10\text{V}$ to $36\text{V}$ (referenced to $V_-$ ); $V_+ = +5\text{V}$ to $+18\text{V}$ and $V_- = -5.0\text{V}$ to $-18\text{V}$ (referenced to DGND $\rightarrow \pm 5\text{V}$ to $\pm 18\text{V}$ ), $V_L = +2.7\text{V}$ to $5.5\text{V}$ , $5\text{ k}\Omega$ , $10\text{ k}\Omega$ , $50\text{ k}\Omega$ , $100\text{ k}\Omega$ devices. Typical specifications represent values for $V_L = 5.5\text{V}$ , $T_A = +25^{\circ}\text{C}$ .						
Parameters	Sym.	Min.	Typ.	Max.	Units	Conditions		
Bandwidth -3 dB (load = 30 pF)	BW	—	480	—	kHz	5 k $\Omega$	8-bit	Code = 7Fh
		—	480	—	kHz		7-bit	Code = 3Fh
		—	240	—	kHz	10 k $\Omega$	8-bit	Code = 7Fh
		—	240	—	kHz		7-bit	Code = 3Fh
		—	48	—	kHz	50 k $\Omega$	8-bit	Code = 7Fh
		—	48	—	kHz		7-bit	Code = 3Fh
		—	24	—	kHz	100 k $\Omega$	8-bit	Code = 7Fh
		—	24	—	kHz		7-bit	Code = 3Fh
$V_W$ Settling Time ( $V_A = 10\text{V}$ , $V_B = 0\text{V}$ , $\pm 1\text{LSb}$ error band, $C_L = 50\text{ pF}$ ) (see <a href="#">Appendix B.17</a> )	$t_S$	—	1	—	$\mu\text{s}$	5 k $\Omega$	Code = 00h $\rightarrow$ FFh (7Fh); FFh (7Fh) $\rightarrow$ 00h	
		—	1	—	$\mu\text{s}$	10 k $\Omega$	Code = 00h $\rightarrow$ FFh (7Fh); FFh (7Fh) $\rightarrow$ 00h	
		—	2.5	—	$\mu\text{s}$	50 k $\Omega$	Code = 00h $\rightarrow$ FFh (7Fh); FFh (7Fh) $\rightarrow$ 00h	
		—	5	—	$\mu\text{s}$	100 k $\Omega$	Code = 00h $\rightarrow$ FFh (7Fh); FFh (7Fh) $\rightarrow$ 00h	

## AC/DC CHARACTERISTICS (CONTINUED)

DC Characteristics		Standard Operating Conditions (unless otherwise specified)						
		Operating Temperature $-40^{\circ}\text{C} \leq T_A \leq +125^{\circ}\text{C}$ (extended)						
		All parameters apply across the specified operating ranges unless noted.						
		$V_+ = 10\text{V}$ to $36\text{V}$ (referenced to $V_-$ );						
		$V_+ = +5\text{V}$ to $+18\text{V}$ and $V_- = -5.0\text{V}$ to $-18\text{V}$ (referenced to DGND $\rightarrow \pm 5\text{V}$ to $\pm 18\text{V}$ ),						
		$V_L = +2.7\text{V}$ to $5.5\text{V}$ , $5\text{ k}\Omega$ , $10\text{ k}\Omega$ , $50\text{ k}\Omega$ , $100\text{ k}\Omega$ devices.						
		Typical specifications represent values for $V_L = 5.5\text{V}$ , $T_A = +25^{\circ}\text{C}$ .						
Parameters	Sym.	Min.	Typ.	Max.	Units	Conditions		
Rheostat Integral Nonlinearity (Note 12, Note 13, Note 14, Note 17) (see Appendix B.5)	R-INL	-2.0	—	+2.0	LSb	5 k $\Omega$	8-bit	$I_W = 6.0\text{ mA}$ , $(V_+ - V_-) = 36\text{V}$ (Note 2)
		-2.5	—	+2.5	LSb			$I_W = 3.3\text{ mA}$ , $(V_+ - V_-) = 20\text{V}$ (Note 2)
		-4.5	—	+4.5	LSb			$I_W = 1.7\text{ mA}$ , $(V_+ - V_-) = 10\text{V}$
		-1.0	—	+1.0	LSb		7-bit	$I_W = 6.0\text{ mA}$ , $(V_+ - V_-) = 36\text{V}$ (Note 2)
		-1.5	—	+1.5	LSb			$I_W = 3.3\text{ mA}$ , $(V_+ - V_-) = 20\text{V}$ (Note 2)
		-2.0	—	+2.0	LSb			$I_W = 1.7\text{ mA}$ , $(V_+ - V_-) = 10\text{V}$
		-1.2	—	+1.2	LSb	10 k $\Omega$	8-bit	$I_W = 3.0\text{ mA}$ , $(V_+ - V_-) = 36\text{V}$ (Note 2)
		-1.75	—	+1.75	LSb			$I_W = 1.7\text{ mA}$ , $(V_+ - V_-) = 20\text{V}$ (Note 2)
		-2.0	—	+2.0	LSb			$I_W = 830\text{ }\mu\text{A}$ , $(V_+ - V_-) = 10\text{V}$
		-0.6	—	+0.6	LSb		7-bit	$I_W = 3.0\text{ mA}$ , $(V_+ - V_-) = 36\text{V}$ (Note 2)
		-0.8	—	+0.8	LSb			$I_W = 1.7\text{ mA}$ , $(V_+ - V_-) = 20\text{V}$ (Note 2)
		-1.1	—	+1.1	LSb			$I_W = 830\text{ }\mu\text{A}$ , $(V_+ - V_-) = 10\text{V}$
		-1.0	—	+1.0	LSb	50 k $\Omega$	8-bit	$I_W = 600\text{ }\mu\text{A}$ , $(V_+ - V_-) = 36\text{V}$ (Note 2)
		-1.0	—	+1.0	LSb			$I_W = 330\text{ }\mu\text{A}$ , $(V_+ - V_-) = 20\text{V}$ (Note 2)
		-1.2	—	+1.2	LSb			$I_W = 170\text{ }\mu\text{A}$ , $(V_+ - V_-) = 10\text{V}$
		-0.5	—	+0.5	LSb		7-bit	$I_W = 600\text{ }\mu\text{A}$ , $(V_+ - V_-) = 36\text{V}$ (Note 2)
		-0.5	—	+0.5	LSb			$I_W = 330\text{ }\mu\text{A}$ , $(V_+ - V_-) = 20\text{V}$ (Note 2)
		-0.6	—	+0.6	LSb			$I_W = 170\text{ }\mu\text{A}$ , $(V_+ - V_-) = 10\text{V}$
		-1.0	—	+1.0	LSb	100 k $\Omega$	8-bit	$I_W = 300\text{ }\mu\text{A}$ , $(V_+ - V_-) = 36\text{V}$ (Note 2)
		-1.0	—	+1.0	LSb			$I_W = 170\text{ }\mu\text{A}$ , $(V_+ - V_-) = 20\text{V}$ (Note 2)
		-1.2	—	+1.2	LSb			$I_W = 83\text{ }\mu\text{A}$ , $(V_+ - V_-) = 10\text{V}$
		-0.5	—	+0.5	LSb		7-bit	$I_W = 300\text{ }\mu\text{A}$ , $(V_+ - V_-) = 36\text{V}$ (Note 2)
		-0.5	—	+0.5	LSb			$I_W = 170\text{ }\mu\text{A}$ , $(V_+ - V_-) = 20\text{V}$ (Note 2)
		-0.6	—	+0.6	LSb			$I_W = 83\text{ }\mu\text{A}$ , $(V_+ - V_-) = 10\text{V}$

Note 2: This parameter is not tested, but specified by characterization.

Note 12: Nonlinearity is affected by wiper resistance ( $R_W$ ), which changes significantly over voltage and temperature.

Note 13: Externally connected to a Rheostat configuration (RBW), and then tested.

Note 14: Wiper current ( $I_W$ ) condition determined by  $R_{AB(\text{max})}$  and Voltage Condition, the delta voltage between  $V_+$  and  $V_-$  (voltages are 36V, 20V, and 10V).

Note 17: Analog switch leakage affects this specification. Higher temperatures increase the switch leakage.

# MCP45HVX1

## AC/DC CHARACTERISTICS (CONTINUED)

DC Characteristics		Standard Operating Conditions (unless otherwise specified)							
		Operating Temperature $-40^{\circ}\text{C} \leq T_A \leq +125^{\circ}\text{C}$ (extended)							
		All parameters apply across the specified operating ranges unless noted.							
		$V_+ = 10\text{V}$ to $36\text{V}$ (referenced to $V_-$ );							
		$V_+ = +5\text{V}$ to $+18\text{V}$ and $V_- = -5.0\text{V}$ to $-18\text{V}$ (referenced to DGND $\rightarrow \pm 5\text{V}$ to $\pm 18\text{V}$ ),							
		$V_L = +2.7\text{V}$ to $5.5\text{V}$ , $5\text{ k}\Omega$ , $10\text{ k}\Omega$ , $50\text{ k}\Omega$ , $100\text{ k}\Omega$ devices.							
		Typical specifications represent values for $V_L = 5.5\text{V}$ , $T_A = +25^{\circ}\text{C}$ .							
Parameters	Sym.	Min.	Typ.	Max.	Units	Conditions			
Rheostat Differential Nonlinearity ( <b>Note 12</b> , <b>Note 13</b> , <b>Note 14</b> , <b>Note 17</b> ) (see <b>Appendix B.5</b> )	R-DNL	-0.5	—	+0.5	LSb	5 k $\Omega$	8-bit	$I_W = 6.0\text{ mA}$ , $(V_+ - V_-) = 36\text{V}$ ( <b>Note 2</b> )	
		-0.5	—	+0.5	LSb			$I_W = 3.3\text{ mA}$ , $(V_+ - V_-) = 20\text{V}$ ( <b>Note 2</b> )	
		-0.8	—	+0.8	LSb			$I_W = 1.7\text{ mA}$ , $(V_+ - V_-) = 10\text{V}$	
		-0.25	—	+0.25	LSb		7-bit	$I_W = 6.0\text{ mA}$ , $(V_+ - V_-) = 36\text{V}$ ( <b>Note 2</b> )	
		-0.25	—	+0.25	LSb			$I_W = 3.3\text{ mA}$ , $(V_+ - V_-) = 20\text{V}$ ( <b>Note 2</b> )	
		-0.4	—	+0.4	LSb			$I_W = 1.7\text{ mA}$ , $(V_+ - V_-) = 10\text{V}$	
		-0.5	—	+0.5	LSb	10 k $\Omega$	8-bit	$I_W = 3.0\text{ mA}$ , $(V_+ - V_-) = 36\text{V}$ ( <b>Note 2</b> )	
		-0.5	—	+0.5	LSb			$I_W = 1.7\text{ mA}$ , $(V_+ - V_-) = 20\text{V}$ ( <b>Note 2</b> )	
		-0.5	—	+0.5	LSb			$I_W = 830\text{ }\mu\text{A}$ , $(V_+ - V_-) = 10\text{V}$	
		-0.25	—	+0.25	LSb		7-bit	$I_W = 3.0\text{ mA}$ , $(V_+ - V_-) = 36\text{V}$ ( <b>Note 2</b> )	
		-0.25	—	+0.25	LSb			$I_W = 1.7\text{ mA}$ , $(V_+ - V_-) = 20\text{V}$ ( <b>Note 2</b> )	
		-0.25	—	+0.25	LSb			$I_W = 830\text{ }\mu\text{A}$ , $(V_+ - V_-) = 10\text{V}$	
		-0.5	—	+0.5	LSb	50 k $\Omega$	8-bit	$I_W = 600\text{ }\mu\text{A}$ , $(V_+ - V_-) = 36\text{V}$ ( <b>Note 2</b> )	
		-0.5	—	+0.5	LSb			$I_W = 330\text{ }\mu\text{A}$ , $(V_+ - V_-) = 20\text{V}$ ( <b>Note 2</b> )	
		-0.5	—	+0.5	LSb			$I_W = 170\text{ }\mu\text{A}$ , $(V_+ - V_-) = 10\text{V}$	
		-0.25	—	+0.25	LSb		7-bit	$I_W = 600\text{ }\mu\text{A}$ , $(V_+ - V_-) = 36\text{V}$ ( <b>Note 2</b> )	
		-0.25	—	+0.25	LSb			$I_W = 330\text{ }\mu\text{A}$ , $(V_+ - V_-) = 20\text{V}$ ( <b>Note 2</b> )	
		-0.25	—	+0.25	LSb			$I_W = 170\text{ }\mu\text{A}$ , $(V_+ - V_-) = 10\text{V}$	
		-0.5	—	+0.5	LSb	100 k $\Omega$	8-bit	$I_W = 300\text{ }\mu\text{A}$ , $(V_+ - V_-) = 36\text{V}$ ( <b>Note 2</b> )	
		-0.5	—	+0.5	LSb			$I_W = 170\text{ }\mu\text{A}$ , $(V_+ - V_-) = 20\text{V}$ ( <b>Note 2</b> )	
		-0.5	—	+0.5	LSb			$I_W = 83\text{ }\mu\text{A}$ , $(V_+ - V_-) = 10\text{V}$	
		-0.25	—	+0.25	LSb		7-bit	$I_W = 300\text{ }\mu\text{A}$ , $(V_+ - V_-) = 36\text{V}$ ( <b>Note 2</b> )	
		-0.25	—	+0.25	LSb			$I_W = 170\text{ }\mu\text{A}$ , $(V_+ - V_-) = 20\text{V}$ ( <b>Note 2</b> )	
		-0.25	—	+0.25	LSb			$I_W = 83\text{ }\mu\text{A}$ , $(V_+ - V_-) = 10\text{V}$	

**Note 2:** This parameter is not tested, but specified by characterization.

**Note 12:** Nonlinearity is affected by wiper resistance ( $R_W$ ), which changes significantly over voltage and temperature.

**Note 13:** Externally connected to a Rheostat configuration (RBW), and then tested.

**Note 14:** Wiper current ( $I_W$ ) condition determined by  $R_{AB(max)}$  and Voltage Condition, the delta voltage between  $V_+$  and  $V_-$  (voltages are 36V, 20V, and 10V).

**Note 17:** Analog switch leakage affects this specification. Higher temperatures increase the switch leakage.

## AC/DC CHARACTERISTICS (CONTINUED)

DC Characteristics		Standard Operating Conditions (unless otherwise specified) Operating Temperature $-40^{\circ}\text{C} \leq T_A \leq +125^{\circ}\text{C}$ (extended) All parameters apply across the specified operating ranges unless noted. $V_+ = 10\text{V}$ to $36\text{V}$ (referenced to $V_-$ ); $V_+ = +5\text{V}$ to $+18\text{V}$ and $V_- = -5.0\text{V}$ to $-18\text{V}$ (referenced to DGND $\rightarrow \pm 5\text{V}$ to $\pm 18\text{V}$ ), $V_L = +2.7\text{V}$ to $5.5\text{V}$ , $5\text{ k}\Omega$ , $10\text{ k}\Omega$ , $50\text{ k}\Omega$ , $100\text{ k}\Omega$ devices. Typical specifications represent values for $V_L = 5.5\text{V}$ , $T_A = +25^{\circ}\text{C}$ .				
Parameters	Sym.	Min.	Typ.	Max.	Units	Conditions
Capacitance ( $P_A$ )	$C_A$	—	75	—	pF	Measured to $V_-$ , $f = 1\text{ MHz}$ , Wiper code = Mid Scale
Capacitance ( $P_W$ )	$C_W$	—	120	—	pF	Measured to $V_-$ , $f = 1\text{ MHz}$ , Wiper code = Mid Scale
Capacitance ( $P_B$ )	$C_B$	—	75	—	pF	Measured to $V_-$ , $f = 1\text{ MHz}$ , Wiper code = Mid Scale
Common-Mode Leakage	$I_{CM}$	—	5	—	nA	$V_A = V_B = V_W$
Digital Interface Pin Capacitance	$C_{IN}$ , $C_{OUT}$	—	10	—	pF	$f_C = 400\text{ kHz}$
<b>Digital Inputs/Outputs (SDA, SCL, A0, A1, SHDN, WLAT)</b>						
Schmitt Trigger High-Input Threshold	$V_{IH}$	$0.7 V_L$	—	$V_L + 0.3\text{V}$	V	$1.8\text{V} \leq V_L \leq 5.5\text{V}$
Schmitt Trigger Low-Input Threshold	$V_{IL}$	DGND - $0.5\text{V}$	—	$0.3 V_L$	V	
Hysteresis of Schmitt Trigger Inputs	$V_{HYS}$	—	$0.1 V_L$	—	V	
Output Low Voltage (SDA)	$V_{OL}$	DGND	—	$0.2 V_L$	V	$V_L = 5.5\text{V}$ , $I_{OL} = 5\text{ mA}$
		DGND	—	$0.2 V_L$	V	$V_L = 1.8\text{V}$ , $I_{OL} = 800\text{ }\mu\text{A}$
Input Leakage Current	$I_{IL}$	-1		1	$\mu\text{A}$	$V_{IN} = V_L$ and $V_{IN} = \text{DGND}$

# MCP45HVX1

## AC/DC CHARACTERISTICS (CONTINUED)

DC Characteristics		Standard Operating Conditions (unless otherwise specified)					
		Operating Temperature $-40^{\circ}\text{C} \leq T_A \leq +125^{\circ}\text{C}$ (extended)					
		All parameters apply across the specified operating ranges unless noted.					
		$V_+ = 10\text{V}$ to $36\text{V}$ (referenced to $V_-$ );					
		$V_+ = +5\text{V}$ to $+18\text{V}$ and $V_- = -5.0\text{V}$ to $-18\text{V}$ (referenced to DGND $\rightarrow \pm 5\text{V}$ to $\pm 18\text{V}$ ),					
		$V_L = +2.7\text{V}$ to $5.5\text{V}$ , $5\text{ k}\Omega$ , $10\text{ k}\Omega$ , $50\text{ k}\Omega$ , $100\text{ k}\Omega$ devices.					
		Typical specifications represent values for $V_L = 5.5\text{V}$ , $T_A = +25^{\circ}\text{C}$ .					
Parameters	Sym.	Min.	Typ.	Max.	Units	Conditions	
<b>RAM (Wiper, TCON) Value</b>							
Wiper Value Range	N	0h	—	FFh	hex	8-bit	
		0h	—	7Fh	hex	7-bit	
Wiper POR/BOR Value	$N_{\text{POR/BOR}}$	7Fh			hex	8-bit	
		3Fh			hex	7-bit	
TCON Value Range	N	0h	—	FFh	hex		
TCON POR/BOR Value	$N_{\text{TCON}}$	FF			hex	All Terminals connected	
<b>Power Requirements</b>							
Power Supply Sensitivity (see <a href="#">Appendix B.20</a> )	PSS	—	0.0015	0.0035	%/%	8-bit	$V_L = 2.7\text{V}$ to $5.5\text{V}$ , $V_+ = 18\text{V}$ , $V_- = -18\text{V}$ , Code = 7Fh
		—	0.0015	0.0035	%/%	7-bit	$V_L = 2.7\text{V}$ to $5.5\text{V}$ , $V_+ = 18\text{V}$ , $V_- = -18\text{V}$ , Code = 3Fh
Power Dissipation	$P_{\text{DISS}}$	—	260	—	mW	$5\text{ k}\Omega$	$V_L = 5.5\text{V}$ , $V_+ = 18\text{V}$ , $V_- = -18\text{V}$ ( <a href="#">Note 15</a> )
		—	130	—	mW	$10\text{ k}\Omega$	
		—	26	—	mW	$50\text{ k}\Omega$	
		—	13	—	mW	$100\text{ k}\Omega$	

**Note 15:**  $P_{\text{DISS}} = I * V$ , or  $(I_{\text{DDD}} * 5.5\text{V}) + (I_{\text{DDA}} * 36\text{V}) + (I_{\text{AB}} * 36\text{V})$ .

## DC Notes:

1. This specification by design.
2. This parameter is not tested, but specified by characterization.
3. See Absolute Maximum Ratings.
4. V+ voltage is dependent on V- voltage. The maximum delta voltage between V+ and V- is 36V. The digital logic DGND potential can be anywhere between V+ and V-, the  $V_L$  potential must be  $\geq$  DGND and  $\leq$  V+.
5. Minimum value determined by maximum V- to V+ potential equals 36V and minimum  $V_L = 1.8V$  for operation. So  $36V - 1.8V = 34.2V$ .
6. POR/BOR is not rate dependent.
7. Supply current ( $I_{DDD}$  and  $I_{DDA}$ ) is independent of current through the resistor network.
8. Resistance ( $R_{AB}$ ) is defined as the resistance between Terminal A to Terminal B.
9. Ensured by the  $R_{AB}$  specification and Ohm's Law.
10. Measured at  $V_W$  with  $V_A = V+$  and  $V_B = V-$ .
11. Resistor terminals A, W and B's polarity with respect to each other is not restricted.
12. Nonlinearity is affected by wiper resistance ( $R_W$ ), which changes significantly over voltage and temperature.
13. Externally connected to a Rheostat configuration ( $R_{BW}$ ), and then tested.
14. Wiper current ( $I_W$ ) condition determined by  $R_{AB(max)}$  and Voltage Condition, the delta voltage between V+ and V- (voltages are 36V, 20V, and 10V).
15.  $P_{DISS} = I * V$ , or  $( I_{DDD} * 5.5V ) + ( I_{DDA} * 36V ) + ( I_{AB} * 36V )$ .
16. For specified analog performance, V+ must be 20V or greater (unless otherwise noted).
17. Analog switch leakage affects this specification. Higher temperatures increase the switch leakage.
18. During the power-up sequence, to ensure expected analog POR operation, the two power systems (analog and digital) should have a common reference to ensure that the driven DGND voltage is not at a higher potential than the driven V+ voltage.

# MCP45HVX1

## 1.1 Timing Waveforms and Requirements



FIGURE 1-1: Settling Time Waveforms.

TABLE 1-1: WIPER SETTling TIMING

Timing Characteristics		Standard Operating Conditions (unless otherwise specified)					
		Operating Temperature $-40^{\circ}\text{C} \leq T_A \leq +125^{\circ}\text{C}$ (extended)					
		All parameters apply across the specified operating ranges unless noted.					
		$V_+ = 10\text{V}$ to $36\text{V}$ (referenced to $V_-$ );					
		$V_+ = +5\text{V}$ to $+18\text{V}$ and $V_- = -5.0\text{V}$ to $-18\text{V}$ (referenced to $\text{DGND}$ -> $\pm 5\text{V}$ to $\pm 18\text{V}$ ),					
		$V_L = +2.7\text{V}$ to $5.5\text{V}$ , $5\text{ k}\Omega$ , $10\text{ k}\Omega$ , $50\text{ k}\Omega$ , $100\text{ k}\Omega$ devices.					
		Typical specifications represent values for $V_L = 5.5\text{V}$ , $T_A = +25^{\circ}\text{C}$ .					
Parameters	Sym.	Min.	Typ.	Max.	Units	Conditions	
$V_W$ Settling Time ( $V_A = 10\text{V}$ , $V_B = 0\text{V}$ , $\pm 1\text{LSb}$ error band, $C_L = 50\text{ pF}$ )	$t_S$	—	1	—	$\mu\text{s}$	$5\text{ k}\Omega$	Code = 00h -> FFh (7Fh); FFh (7Fh) -> 00h
		—	1	—	$\mu\text{s}$	$10\text{ k}\Omega$	Code = 00h -> FFh (7Fh); FFh (7Fh) -> 00h
		—	2.5	—	$\mu\text{s}$	$50\text{ k}\Omega$	Code = 00h -> FFh (7Fh); FFh (7Fh) -> 00h
		—	5	—	$\mu\text{s}$	$100\text{ k}\Omega$	Code = 00h -> FFh (7Fh); FFh (7Fh) -> 00h





**FIGURE 1-2:** I<sup>2</sup>C Bus Start/Stop Bits Timing Waveforms.

**TABLE 1-2: I<sup>2</sup>C BUS START/STOP BITS AND WLAT REQUIREMENTS**

I <sup>2</sup> C™ AC Characteristics		Standard Operating Conditions (unless otherwise specified) Operating Temperature -40°C ≤ T <sub>A</sub> ≤ +125°C (Extended) 2.7V ≤ V <sub>L</sub> ≤ 5.5V; DGND = V- (Note 1)					
Param. No.	Symbol	Characteristic	Min.	Max.	Units	Conditions	
	F <sub>SCL</sub>		Standard mode	0	100	kHz	C <sub>b</sub> = 400 pF, 1.8V ≤ V <sub>L</sub> ≤ 5.5V
			Fast mode	0	400	kHz	C <sub>b</sub> = 400 pF, 2.7V ≤ V <sub>L</sub> ≤ 5.5V
			High Speed 1.7	0	1.7	MHz	C <sub>b</sub> = 400 pF, 4.5V ≤ V <sub>L</sub> ≤ 5.5V
			High Speed 3.4	0	3.4	MHz	C <sub>b</sub> = 100 pF, 4.5V ≤ V <sub>L</sub> ≤ 5.5V
D102	C <sub>b</sub>	Bus capacitive loading	100 kHz mode	—	400	pF	
			400 kHz mode	—	400	pF	
			1.7 MHz mode	—	400	pF	
			3.4 MHz mode	—	100	pF	
90	T <sub>SU:STA</sub>	Start condition Setup time	100 kHz mode	4700	—	ns	Only relevant for repeated Start condition
			400 kHz mode	600	—	ns	
			1.7 MHz mode	160	—	ns	
			3.4 MHz mode	160	—	ns	
91	T <sub>HD:STA</sub>	Start condition Hold time	100 kHz mode	4000	—	ns	After this period the first clock pulse is generated
			400 kHz mode	600	—	ns	
			1.7 MHz mode	160	—	ns	
			3.4 MHz mode	160	—	ns	
92	T <sub>SU:STO</sub>	Stop condition Setup time	100 kHz mode	4000	—	ns	
			400 kHz mode	600	—	ns	
			1.7 MHz mode	160	—	ns	
			3.4 MHz mode	160	—	ns	
93	T <sub>HD:STO</sub>	Stop condition Hold time	100 kHz mode	4000	—	ns	
			400 kHz mode	600	—	ns	
			1.7 MHz mode	160	—	ns	
			3.4 MHz mode	160	—	ns	
94	T <sub>WLSU</sub>	WLAT ↑ to SCL ↑ (write data ACK bit) Setup time	10	—	ns	Write Data delayed, Note 9	
95	T <sub>WLHD</sub>	SCL ↑ to WLAT ↑ (write data ACK bit) Hold time	250	—	ns	Write Data delayed, Note 9	
96	T <sub>WLATL</sub>	WLAT High or Low Time	2	—	μs		

**Note 1:** Serial Interface has equal performance when DGND ≥ V- + 0.9V.

**Note 9:** The transition of the WLAT signal between 10 ns before the rising edge (Spec 94) and 200 ns after the rising edge (Spec 95) of the SCL signal is indeterminate if the Write Data is delayed or not.

# MCP45HVX1



**FIGURE 1-3:** I<sup>2</sup>C Bus Timing Waveforms.

**TABLE 1-3: I<sup>2</sup>C BUS REQUIREMENTS (SLAVE MODE)**

I <sup>2</sup> C™ AC Characteristics		Standard Operating Conditions (unless otherwise specified)					
		Operating Temperature $-40^{\circ}\text{C} \leq T_A \leq +125^{\circ}\text{C}$ (Extended)					
		$2.7\text{V} \leq V_L \leq 5.5\text{V}$ ; DGND = V- (Note 1)					
Param. No.	Symbol	Characteristic	Min.	Max.	Units	Conditions	
100	T <sub>HIGH</sub>	Clock high time	100 kHz mode	4000	—	ns	1.8V-5.5V
			400 kHz mode	600	—	ns	2.7V-5.5V
			1.7 MHz mode	120	—	ns	4.5V-5.5V
			3.4 MHz mode	60	—	ns	4.5V-5.5V
101	T <sub>LOW</sub>	Clock low time	100 kHz mode	4700	—	ns	1.8V-5.5V
			400 kHz mode	1300	—	ns	2.7V-5.5V
			1.7 MHz mode	320	—	ns	4.5V-5.5V
			3.4 MHz mode	160	—	ns	4.5V-5.5V
102A (6)	T <sub>RSCL</sub>	SCL rise time	100 kHz mode	—	1000	ns	Cb is specified to be from 10 to 400 pF (100 pF maximum for 3.4 MHz mode)
			400 kHz mode	$20 + 0.1C_b$	300	ns	
			1.7 MHz mode	20	80	ns	
			1.7 MHz mode	20	160	ns	After a Repeated Start condition or an Acknowledge bit
			3.4 MHz mode	10	40	ns	
			3.4 MHz mode	10	80	ns	After a Repeated Start condition or an Acknowledge bit
102B (6)	T <sub>RSDA</sub>	SDA rise time	100 kHz mode	—	1000	ns	Cb is specified to be from 10 to 400 pF (100 pF max for 3.4 MHz mode)
			400 kHz mode	$20 + 0.1C_b$	300	ns	
			1.7 MHz mode	20	160	ns	
			3.4 MHz mode	10	80	ns	

**Note 1:** Serial Interface has equal performance when DGND  $\geq$  V- + 0.9V.

**Note 6:** Not tested.

**TABLE 1-4: I<sup>2</sup>C BUS REQUIREMENTS (SLAVE MODE) (CONTINUED)**

I <sup>2</sup> C™ AC Characteristics		Standard Operating Conditions (unless otherwise specified) Operating Temperature $-40^{\circ}\text{C} \leq T_A \leq +125^{\circ}\text{C}$ (Extended) $2.7\text{V} \leq V_L \leq 5.5\text{V}$ ; DGND = V- (Note 1)					
Param. No.	Sym.	Characteristic		Min.	Max.	Units	Conditions
103A <sup>(5)</sup>	T <sub>FSCL</sub>	SCL fall time	100 kHz mode	—	300	ns	Cb is specified to be from 10 to 400 pF (100 pF max for 3.4 MHz mode)
			400 kHz mode	20 + 0.1Cb	300	ns	
			1.7 MHz mode	20	80	ns	
			3.4 MHz mode	10	40	ns	
103B <sup>(5)</sup>	T <sub>FSDA</sub>	SDA fall time	100 kHz mode	—	300	ns	Cb is specified to be from 10 to 400 pF (100 pF max for 3.4 MHz mode)
			400 kHz mode	20 + 0.1Cb <sup>(4)</sup>	300	ns	
			1.7 MHz mode	20	160	ns	
			3.4 MHz mode	10	80	ns	
106	T <sub>HD:DAT</sub>	Data input hold time	100 kHz mode	0	—	ns	1.8V-5.5V, <b>Note 7</b>
			400 kHz mode	0	—	ns	2.7V-5.5V, <b>Note 7</b>
			1.7 MHz mode	0	—	ns	4.5V-5.5V, <b>Note 7</b>
			3.4 MHz mode	0	—	ns	4.5V-5.5V, <b>Note 7</b>
107	T <sub>SU:DAT</sub>	Data input setup time	100 kHz mode	250	—	ns	<b>Note 3</b>
			400 kHz mode	100	—	ns	
			1.7 MHz mode	10	—	ns	
			3.4 MHz mode	10	—	ns	
109	T <sub>AA</sub>	Output valid from clock	100 kHz mode	—	3450	ns	<b>Note 2</b>
			400 kHz mode	—	900	ns	
			1.7 MHz mode	—	150	ns	Cb = 100 pF, <b>Note 2, Note 8</b>
				—	310	ns	Cb = 400 pF, <b>Note 2, Note 6</b>
			3.4 MHz mode	—	150	ns	Cb = 100 pF, <b>Note 2</b>
110	T <sub>BUF</sub>	Bus free time	100 kHz mode	4700	—	ns	Time the bus must be free before a new transmission can start
			400 kHz mode	1300	—	ns	
			1.7 MHz mode	N.A.	—	ns	
			3.4 MHz mode	N.A.	—	ns	
	T <sub>SP</sub>	Input filter spike suppression (SDA and SCL)	100 kHz mode	—	50	ns	NXP Spec states N.A.
			400 kHz mode	—	50	ns	
			1.7 MHz mode	—	10	ns	Spike suppression
			3.4 MHz mode	—	10	ns	Spike suppression

**Note 1:** Serial Interface has equal performance when DGND  $\geq V- + 0.9\text{V}$ .

**Note 2:** As a transmitter, the device must provide this internal minimum delay time to bridge the undefined region (minimum 300 ns) of the falling edge of SCL to avoid unintended generation of Start or Stop conditions.

**Note 3:** A fast-mode (400 kHz) I<sup>2</sup>C bus device can be used in a standard mode (100 kHz) I<sup>2</sup>C bus system, but the requirement  $t_{\text{SU:DAT}} \geq 250$  ns must then be met. This will automatically be the case if the device does not stretch the Low period of the SCL signal. If such a device does stretch the Low period of the SCL signal, it must output the next data bit to the SDA line  $T_R \text{ max.} + t_{\text{SU:DAT}} = 1000 + 250 = 1250$  ns (according to the standard mode I<sup>2</sup>C bus specification) before the SCL line is released.

**Note 6:** Not tested.

**Note 7:** A master transmitter must provide a delay to ensure that difference between SDA and SCL fall times do not unintentionally create a Start or Stop condition.

**Note 8:** Ensured by the T<sub>AA</sub> 3.4 MHz specification test.

# MCP45HVX1

---

## Timing Table Notes:

1. Serial Interface has equal performance when  $DGND \geq V_{-} + 0.9V$ .
2. As a transmitter, the device must provide this internal minimum delay time to bridge the undefined region (minimum 300 ns) of the falling edge of SCL to avoid unintended generation of Start or Stop conditions.
3. A fast-mode (400 kHz) I<sup>2</sup>C bus device can be used in a standard mode (100 kHz) I<sup>2</sup>C bus system, but the requirement  $t_{SU;DAT} \geq 250$  ns must then be met. This will automatically be the case if the device does not stretch the Low period of the SCL signal. If such a device does stretch the Low period of the SCL signal, it must output the next data bit to the SDA line  
 $T_R \text{ max.} + t_{SU;DAT} = 1000 + 250 = 1250$  ns (according to the standard mode I<sup>2</sup>C bus specification) before the SCL line is released.
4. The MCP45HVX1 device must provide a data hold time to bridge the undefined part between  $V_{IH}$  and  $V_{IL}$  of the falling edge of the SCL signal. This specification is not a part of the I<sup>2</sup>C specification, but must be tested in order to ensure that the output data will meet the setup and hold specifications for the receiving device.
5. Use  $C_b$  in pF for the calculations.
6. Not tested.
7. A master transmitter must provide a delay to ensure that difference between SDA and SCL fall times do not unintentionally create a Start or Stop condition.
8. Ensured by the  $T_{AA}$  3.4 MHz specification test.
9. The transition of the  $\overline{WLAT}$  signal between 10 ns before the rising edge (Spec 94) and 200 ns after the rising edge (Spec 95) of the SCL signal is indeterminant if the Write Data is delayed or not.

## TEMPERATURE CHARACTERISTICS

**Electrical Specifications:** Unless otherwise indicated,  $V_L = +2.7V$  to  $+5.5V$ ,  $V+ = +10V$  to  $+36V$ ,  $V- = DGND = GND$ .

Parameters	Sym.	Min.	Typ.	Max.	Units	Conditions
<b>Temperature Ranges</b>						
Specified Temperature Range	$T_A$	-40	—	+125	°C	
Operating Temperature Range	$T_A$	-40	—	+125	°C	
Storage Temperature Range	$T_A$	-65	—	+150	°C	
<b>Thermal Package Resistances</b>						
Thermal Resistance, 14L-TSSOP (ST)	$\theta_{JA}$	—	100	—	°C/W	
Thermal Resistance, 20L-QFN (MQ)	$\theta_{JA}$	—	36.1	—	°C/W	

# MCP45HVX1

---

## 2.0 TYPICAL PERFORMANCE CURVES

**Note:** The device Performance Curves are available in a separate document. This is done to keep the file size of this PDF document less than the 10MB file attachment limit of many mail servers. The MCP45HVX1 Performance Curves document is literature number DS20005307, and can be found on the Microchip web site. Look at the MCP45HVX1 Product Page under Documentation and Software, in the Data Sheets category.

NOTES:

# MCP45HVX1

## 3.0 PIN DESCRIPTIONS

The descriptions of the pins are listed in [Table 3-1](#). Additional descriptions of the device pins follows.

**TABLE 3-1: PINOUT DESCRIPTION FOR THE MCP45HVX1**

Pin					Function
TSSOP	QFN	Symbol	Type	Buffer Type	
14L	20L				
1	1	$V_L$	P	—	Positive Digital Power Supply Input
2	2	SCL	I	ST	I <sup>2</sup> C™ Serial Clock pin
3	3	A1	I	ST	I <sup>2</sup> C Address 1
4	4	SDA	I/O	ST	I <sup>2</sup> C Serial Data pin
5	5	A0	I	ST	I <sup>2</sup> C Address 0
6	6	$\overline{WLAT}$	I	ST	Wiper Latch Enable 0 = Received I <sup>2</sup> C Shift Register Buffer (SPBUF) value is transferred to Wiper register. 1 = Received I <sup>2</sup> C data value is held in I <sup>2</sup> C Shift Register Buffer (SPBUF).
7	8, 9, 10, 17, 18, 19, 20	NC	—	—	Pin not internally connected to die. To reduce noise coupling, connect pin either to DGND or $V_L$ .
8	7	$\overline{SHDN}$	I	ST	Shutdown
9	11	DGND	P	—	Ground
10	12	V-	P	—	Analog Negative Potential Supply
11	13	P0B	I/O	A	Potentiometer 0 Terminal B
12	14	P0W	I/O	A	Potentiometer 0 Wiper Terminal
13	15	P0A	I/O	A	Potentiometer 0 Terminal A
14	16	V+	P	—	Analog Positive Potential Supply
—	21	EP	P	—	Exposed Pad, connect to V- signal or Not Connected (floating). ( <a href="#">Note 1</a> )

**Legend:** A = Analog                      ST = Schmitt Trigger  
I = Input                                  O = Output                      I/O = Input/Output                      P = Power

**Note 1:** The QFN package has a contact on the bottom of the package. This contact is conductively connected to the die substrate, and therefore should be unconnected or connected to the same ground as the device's V- pin.



### 3.1 Positive Power Supply Input ( $V_L$ )

The  $V_L$  pin is the device's positive power supply input. The input power supply is relative to DGND and can range from 1.8V to 5.5V. A decoupling capacitor on  $V_L$  (to DGND) is recommended to achieve maximum performance.

### 3.2 Digital Ground (DGND)

The DGND pin is the device's digital ground reference.

### 3.3 Analog Positive Voltage ( $V+$ )

Analog circuitry positive supply voltage. Must have a higher potential than the  $V-$  pin.

### 3.4 Analog Negative Voltage ( $V-$ )

Analog circuitry negative supply voltage. The  $V-$  potential must be lower than or equal to the DGND pin potential.

### 3.5 Serial Clock (SCL)

The SCL pin is the serial interface's Serial Clock pin. This pin is connected to the Host Controller's SCL pin. The MCP45HVX1 is an I<sup>2</sup>C slave device, so its SCL pin is an input-only pin.

### 3.6 Serial Data (SDA)

The SDA pin is the serial interface's Serial Data In/Out pin. This pin is connected to the Host Controller's SDA pin. The SDA pin is an open-drain N-Channel driver.

This pin allows the host controller to read and write the digital potentiometer registers (Wiper and TCON).

### 3.7 Address 0 ( $A_0$ )

The  $A_0$  pin is the Address 0 input for the I<sup>2</sup>C interface. At the device's POR/BOR the value of the  $A_0$  address bit is latched. This input along with the  $A_1$  pin completes the device address. This allows up to four MCP45HVXX devices to be on a single I<sup>2</sup>C bus.

### 3.8 Address 1 ( $A_1$ )

The  $A_1$  pin is the I<sup>2</sup>C interface's Address 1 pin. Along with the  $A_0$  pins, up to four MCP45HVXX devices can be on a single I<sup>2</sup>C bus.

### 3.9 Wiper Latch ( $\overline{WLAT}$ )

The  $\overline{WLAT}$  pin is used to hold off the transfer of the received wiper value (in the Shift register) to the Wiper register. This allows this transfer to be synchronized to an external event (such as zero crossing). See [Section 4.3.2](#).

### 3.10 Shutdown ( $\overline{SHDN}$ )

The  $\overline{SHDN}$  pin is used to force the resistor network terminals into the hardware shutdown state. See [Section 4.3.1](#).

### 3.11 Potentiometer Terminal B

The Terminal B pin is connected to the internal potentiometer's Terminal B.

The potentiometer's Terminal B is the fixed connection to the zero-scale wiper value of the digital potentiometer. This corresponds to a wiper value of 0x00 for both 7-bit and 8-bit devices.

The Terminal B pin does not have a polarity relative to the Terminal W or A pins. The Terminal B pin can support both positive and negative current. The voltage on Terminal B must be between  $V+$  and  $V-$ .

### 3.12 Potentiometer Wiper (W) Terminal

The Terminal W pin is connected to the internal potentiometer's Terminal W (the wiper). The wiper terminal is the adjustable terminal of the digital potentiometer. The Terminal W pin does not have a polarity relative to Terminal's A or B pins. The Terminal W pin can support both positive and negative current. The voltage on Terminal W must be between  $V+$  and  $V-$ .

If the  $V+$  voltage powers-up before the  $V_L$  voltage, the wiper is forced to mid scale once the analog POR voltage is crossed.

If the  $V+$  voltage powers-up after the  $V_L$  voltage is greater than the digital POR voltage, the wiper is forced to the value in the Wiper register once the analog POR voltage is crossed.

### 3.13 Potentiometer Terminal A

The Terminal A pin is connected to the internal potentiometer's Terminal A.

The potentiometer's Terminal A is the fixed connection to the full scale wiper value of the digital potentiometer. This corresponds to a wiper value of 0xFF for 8-bit devices or 0x7F for 7-bit devices.

The Terminal A pin does not have a polarity relative to the Terminal W or B pins. The Terminal A pin can support both positive and negative current. The voltage on Terminal A must be between  $V+$  and  $V-$ .

### 3.14 Exposed Pad (EP)

This pad is only on the bottom of the QFN packages. This pad is conductively connected to the device substrate. The EP pin must be connected to the  $V-$  signal or left floating. This pad could be connected to a PCB heat sink to assist as a heat sink for the device.

### 3.15 Not Connected (NC)

This pin is not internally connected to the die. To reduce noise coupling, these pins should be connected to either  $V_L$  or DGND.

# MCP45HVX1

## 4.0 FUNCTIONAL OVERVIEW

This data sheet covers a family of two volatile digital potentiometer devices that will be referred to as MCP45HVX1. These devices are:

- MCP45HV31 (7-bit resolution)
- MCP45HV51 (8-bit resolution)

As the [Device Block Diagram](#) shows, there are six main functional blocks. These are:

- [Operating Voltage Range](#)
- [POR/BOR Operation](#)
- [Memory Map](#)
- [Control Module](#)
- [Resistor Network](#)
- [Serial Interface \(I<sup>2</sup>C\)](#)

The POR/BOR operation and the Memory Map are discussed in this section and the Resistor Network and I<sup>2</sup>C operation are described in their own sections. The [Device Commands](#) are discussed in [Section 7.0](#).

## 4.1 Operating Voltage Range

The MCP45HVX1 devices have four voltage signals. These are:

- V+ – Analog Power
- V<sub>L</sub> – Digital Power
- DGND – Digital Ground
- V- – Analog Ground

[Figure 4-1](#) shows the two possible power-up sequences; analog power rails power-up first, or digital power rails power-up first. The device has been designed so that either power rail may power-up first. The device has a POR circuit for both digital power circuitry and analog power circuitry.

If the V+ voltage powers-up before the V<sub>L</sub> voltage, the wiper is forced to mid scale once the analog POR voltage is crossed.

If the V+ voltage powers-up after the V<sub>L</sub> voltage is greater than the digital POR voltage, the wiper is forced to the value in the Wiper register, once the analog POR voltage is crossed.

[Figure 4-2](#) shows the three cases of the digital power signals (V<sub>L</sub>/DGND) with respect to the analog power signals (V+/V-). The device implements level shifts between the digital and analog power systems, which allows the digital interface voltage to be anywhere in the V+/V- voltage window.



**FIGURE 4-1:** Power-On Sequences.



**FIGURE 4-2:** Voltage Ranges.

# MCP45HVX1

## 4.2 POR/BOR Operation

The resistor network's devices are powered by the analog power signals ( $V+/V-$ ), but the digital logic (including the wiper registers) is powered by the digital power signals ( $V_L/DGND$ ). So, both the digital circuitry and analog circuitry have independent POR/BOR circuits.

The wiper position will be forced to the default state when the  $V+$  voltage (relative to  $V-$ ) is above the analog POR/BOR trip point. The Wiper register will be in the default state when the  $V_L$  voltage (relative to  $DGND$ ) is above the digital POR/BOR trip point.

The digital-signal-to-analog-signal voltage level shifters require a minimum voltage between the  $V_L$  and  $V-$  signals. This voltage requirement is below the operating supply voltage specifications. The wiper output may fluctuate while the  $V_L$  voltage is less than the level shifter operating voltage, since the analog values may not reflect the digital value. Output issues may be reduced by powering-up the digital supply voltages to their operating voltage, before powering the analog supply voltage.

### 4.2.1 POWER-ON RESET

Each power system has its own independent Power-On Reset circuitry. This is done so that regardless of the power-up sequencing of the analog and digital power rails, the wiper output will be forced to a default value after minimum conditions are met for either power supply.

Table 4-1 shows the interaction between the analog and digital PORs for the  $V+$  and  $V_L$  voltages on the wiper pin state.

**TABLE 4-1: WIPER PIN STATE BASED ON POR CONDITIONS**

$V_L$ Voltage	$V+$ Voltage		Comments
	$V+ < V_{APOR}$	$V+ \geq V_{APOR}$	
$V_L < V_{DPOR}$	Unknown	Mid Scale	
$V_L \geq V_{DPOR}$	Unknown	Wiper Register Value <sup>(1)</sup>	Wiper register can be updated

**Note 1:** Default POR state of the Wiper register value is the mid-scale value.

### 4.2.1.1 Digital Circuitry

The Digital Power-On Reset (DPOR) is the case where the device's  $V_L$  signal has power applied (referenced from  $DGND$ ) and the voltage rises above the trip point. The Brown-out Reset (BOR) occurs when a device had power applied to it, and the voltage drops below the trip point.

The device's RAM retention voltage ( $V_{RAM}$ ) is lower than the POR/BOR voltage trip point ( $V_{POR}/V_{BOR}$ ). The maximum  $V_{POR}/V_{BOR}$  voltage is less than 1.8V.

When the device powers-up, the device  $V_L$  will cross the  $V_{POR}/V_{BOR}$  voltage. Once the  $V_L$  voltage crosses the  $V_{POR}/V_{BOR}$  voltage, the following happens:

- Volatile wiper registers are loaded with the POR/BOR value
- The TCON registers are loaded with the default values
- The device is capable of digital operation

Table 4-2 shows the default POR/BOR Wiper Register Setting Selection.

When  $V_{POR}/V_{BOR} < V_L < 2.7V$ , the electrical performance may not meet the data sheet specifications. In this region, the device is capable of incrementing, decrementing, reading and writing to its volatile memory if the proper serial command is executed.

**TABLE 4-2: DEFAULT POR/BOR WIPER REGISTER SETTING (DIGITAL)**

Typical $R_{AB}$ Value	Package Code	Default POR Wiper Register Setting <sup>(1)</sup>	Device Resolution	Wiper Code
5.0 k $\Omega$	-502	Mid scale	8-bit	7Fh
			7-bit	3Fh
10.0 k $\Omega$	-103	Mid scale	8-bit	7Fh
			7-bit	3Fh
50.0 k $\Omega$	-503	Mid scale	8-bit	7Fh
			7-bit	3Fh
100.0 k $\Omega$	-104	Mid scale	8-bit	7Fh
			7-bit	3Fh

**Note 1:** Register setting independent of analog power voltage.

## 4.2.1.2 Analog Circuitry

The Analog Power-On Reset (APOR) is the case where the device's  $V_+$  pin voltage has power applied (referenced from  $V_-$ ) and the  $V_+$  pin voltage rises above the trip point.

Once the  $V_L$  pin voltage exceeds the digital POR trip point voltage, the Wiper register will control the wiper setting.

Table 4-3 shows the default POR/BOR wiper setting for when the  $V_L$  pin is not powered ( $<$  digital POR trip point).

**TABLE 4-3: DEFAULT POR/BOR WIPER SETTING (ANALOG)**

Typical $R_{AB}$ Value	Package Code	Default POR Wiper Setting <sup>(1)</sup>		Device Resolution
		Analog Output Position	Wiper Register Code (hex)	
5.0 k $\Omega$	-502	Mid scale	0x7F	8-bit
			0x3F	7-bit
10.0 k $\Omega$	-103	Mid scale	0x7F	8-bit
			0x3F	7-bit
50.0 k $\Omega$	-503	Mid scale	0x7F	8-bit
			0x3F	7-bit
100.0 k $\Omega$	-104	Mid scale	0x7F	8-bit
			0x3F	7-bit

**Note 1:** Wiper setting is dependent on the Wiper register value if the  $V_L$  voltage is greater than the digital POR voltage.



**FIGURE 4-3:**  $DGND$ ,  $V_L$ ,  $V_+$ , and  $V_-$  Signal Waveform Examples.

# MCP45HVX1

## 4.2.2 BROWN-OUT RESET

Each power system has its own independent Brown-Out Reset circuitry. This is done so that regardless of the power-down sequencing of the analog and digital power rails, the wiper output will be forced to a default value after the low-voltage conditions are met for either power supply.

Table 4-4 shows the interaction between the analog and digital BORs for the  $V+$  and  $V_L$  voltages on the wiper pin state.

**TABLE 4-4: WIPER PIN STATE BASED ON BOR CONDITIONS**

$V_L$ Voltage	V+ Voltage		Comments
	$V+ < V_{ABOR}$	$V+ \geq V_{ABOR}$	
$V_L < V_{DBOR}$	Unknown	Mid Scale	
$V_L \geq V_{DBOR}$	Unknown	Wiper Register Value (1)	Wiper register can be updated

**Note 1:** Default POR state of the Wiper register value is the mid-scale value.

### 4.2.2.1 Digital Circuitry

When the device's digital power supply powers-down, the device  $V_L$  pin voltage will cross the digital  $V_{DPOR}/V_{DBOR}$  voltage.

Once the  $V_L$  voltage decreases below the  $V_{DPOR}/V_{DBOR}$  voltage, the following happens:

- Serial Interface is disabled

If the  $V_L$  voltage decreases below the  $V_{RAM}$  voltage, the following happens:

- Volatile wiper registers may become corrupted
- TCON registers may become corrupted

Section 4.2.1, **Power-on Reset** describes what occurs as the voltage recovers above the  $V_{DPOR}/V_{DBOR}$  voltage.

Serial commands not completed due to a brown-out condition may cause the memory location to become corrupted.

The brown-out circuit establishes a minimum  $V_{DBOR}$  threshold for operation ( $V_{DBOR} < 1.8V$ ). The digital BOR voltage ( $V_{DBOR}$ ) is higher than the RAM retention voltage ( $V_{RAM}$ ) so that as the device voltage crosses the digital BOR threshold, the value that is loaded into the volatile Wiper register is not corrupted due to RAM retention issues.

When  $V_L < V_{DBOR}$ , all communications are ignored and potentiometer terminals are forced to the analog BOR state.

Whenever  $V_L$  transitions from  $V_L < V_{DBOR}$  to  $V_L > V_{DBOR}$ , (a POR event) the wiper's POR/BOR value is latched into the Wiper register and the volatile TCON register is forced to the POR/BOR state.

When  $1.8V \leq V_L$ , the device is capable of digital operation.

Table 4-5 shows the digital potentiometer's level of functionality across the entire  $V_L$  range, while Figure 4-4 illustrates the Power-Up and Brown-Out functionality.

### 4.2.2.2 Analog Circuitry

The Analog Brown-Out-Reset (ABOR) is the case where the device's  $V+$  pin has power applied (referenced from  $V-$ ) and the  $V+$  pin voltage drops below the trip point. In this case, the resistor network terminal's pins can become an unknown state.

**TABLE 4-5: DEVICE FUNCTIONALITY AT EACH  $V_L$  REGION**

$V_L$ Level	V+/V- Level	Serial Interface	Potentiometer Terminals <sup>(2)</sup>	Wiper		Comment
				Register Setting	Output <sup>(2)</sup>	
$V_L < V_{DBOR} < 1.8V$	Valid range	Ignored	"Unknown"	Unknown	Invalid	
	Invalid range	Ignored	"Unknown"	Unknown	Invalid	
$V_{DBOR} \leq V_L < 1.8V$	Valid range	"Unknown"	Connected	Volatile Wiper Register initialized	Valid	The volatile registers are forced to the POR/BOR state when $V_L$ transitions above the $V_{DPOR}$ trip point
	Invalid range	"Unknown"	Connected		Invalid	
$1.8V \leq V_L \leq 5.5V$	Valid range	Accepted	Connected	Volatile Wiper Register determines Wiper Setting	Valid	
	Invalid range	Accepted	Connected		Invalid	

**Note 1:** For system voltages below the minimum operating voltage, it is recommended to use a voltage supervisor to hold the system in Reset. This ensures that MCP45HVX1 commands are not attempted out of the operating range of the device.

**2:** Assumes that  $V+ > V_{APOR}$ .



**FIGURE 4-4:** Power-Up and Brown Out - V+/V- at Normal Operating Voltage.

# MCP45HVX1

## 4.3 Control Module

The control module controls the following functionality:

- **Shutdown**
- **Wiper Latch**

### 4.3.1 SHUTDOWN

The MCP45HVX1 has two methods to disconnect the terminal's pins (P0A, P0W, and P0B) from the resistor network. These are:

- Hardware Shutdown pin ( $\overline{\text{SHDN}}$ )
- Terminal Control Register (TCON)

#### 4.3.1.1 Hardware Shutdown Pin Operation

The  $\overline{\text{SHDN}}$  pin has the same functionality as Microchip's family of standard voltage devices. When the  $\overline{\text{SHDN}}$  pin is Low, the P0A terminal will disconnect (become open) while the P0W terminal simultaneously connects to the P0B terminal (see Figure 4-5).

**Note:** When the  $\overline{\text{SHDN}}$  pin is Active ( $V_{IL}$ ), the state of the TCON register bits is overridden (ignored). When the state of the  $\overline{\text{SHDN}}$  pin returns to the Inactive state ( $V_{IH}$ ), the TCON register bits return to controlling the terminal connection state. That is, the value in the TCON register is not corrupted.

The Hardware Shutdown Pin mode does not corrupt the volatile Wiper register. When Shutdown is exited, the device returns to the wiper setting specified by the volatile wiper value. See Section 5.7 for additional description details.

**Note:** When the  $\overline{\text{SHDN}}$  pin is active, the serial interface is not disabled, and serial interface activity is executed.



**FIGURE 4-5:** Hardware Shutdown Resistor Network Configuration.

#### 4.3.1.2 Terminal Control Register

The Terminal Control (TCON) register allows the device's terminal pins to be independently removed from the application circuit. These terminal control settings do not modify the wiper setting values. Also, this has no effect on the serial interface and the memory/wipers are still under full user control.

The resistor network has four TCON bits associated with it. One bit for each terminal (A, W, and B) and one to have a software configuration that matches the configuration of the  $\overline{\text{SHDN}}$  pin. These bits are named R0A, R0W, R0B, and R0HW. Register 4-1 describes the operation of the R0HW, R0A, R0B, and R0W bits.

**Note:** When the R0HW bit forces the resistor network into the hardware  $\overline{\text{SHDN}}$  state, the state of the TCON register R0A, R0W, and R0B bits is overridden (ignored). When the state of the R0HW bit no longer forces the resistor network into the hardware  $\overline{\text{SHDN}}$  state, the TCON register R0A, R0W, and R0B bits return to controlling the terminal connection state. That is, the R0HW bit does not corrupt the state of the R0A, R0W, and R0B bits.

Figure 4-6 shows how the  $\overline{\text{SHDN}}$  pin signal and the R0HW bit signal interact to control the hardware shutdown of each resistor network (independently).



**FIGURE 4-6:** R0HW bit and  $\overline{\text{SHDN}}$  pin Interaction.



## 4.3.2 WIPER LATCH

The wiper latch pin is used to control when the new wiper value in the Wiper register is transferred to the wiper. This is useful for applications that need to synchronize the wiper updates. This may be for synchronization to an external event, such as zero crossing, or to synchronize the update of multiple digital potentiometers.

When the  $\overline{\text{WLAT}}$  pin is High, transfers from the Wiper register to the wiper are inhibited. When the  $\overline{\text{WLAT}}$  pin is Low, transfers may occur from the Wiper register to the wiper. [Figure 4-7](#) shows the interaction of the  $\overline{\text{WLAT}}$  pin during an I<sup>2</sup>C command and the loading of the wiper.

If the external event crossing time is long, then the wiper could be updated the entire time that the  $\overline{\text{WLAT}}$  signal is Low. Once the  $\overline{\text{WLAT}}$  signal goes High, the transfer from the Wiper register is disabled. The Wiper register can continue to be updated.

If the application does not require synchronized Wiper register updates, then the  $\overline{\text{WLAT}}$  pin should be tied Low.

**Note 1:** This feature only inhibits the data transfer from the Wiper register to the wiper.

**2:** When the  $\overline{\text{WLAT}}$  pin becomes active, data transferred to the wiper will not be corrupted due to the Wiper Register Buffer getting loaded from an active I<sup>2</sup>C command.

## 4.3.3 DEVICE CURRENT MODES

There are two current modes for volatile devices. These are:

- Serial Interface Inactive (static operation)
- Serial Interface Active

For the I<sup>2</sup>C interface, static operation occurs when the SDA and the SCL pins are static (High or Low).

# MCP45HVX1



**FIGURE 4-7:**  $\overline{\text{WLAT}}$  Interaction with I<sup>2</sup>C ACK Pulse

## 4.4 Memory Map

The device memory supports 16 locations that are 8-bits wide (16x8 bits). This memory space contains only volatile locations (see [Table 4-7](#)).

### 4.4.1 VOLATILE MEMORY (RAM)

There are two volatile memory locations. These are:

- Volatile Wiper 0
- Terminal Control (TCON0) Register 0

The volatile memory starts functioning at the RAM retention voltage ( $V_{RAM}$ ). The POR/BOR wiper code is shown in [Table 4-6](#).

[Table 4-7](#) shows this memory map and which serial commands operate (and do not) on each of these locations.

Accessing an “invalid” address (for that device) or an invalid command for that address will cause an error condition on the serial interface. A Start bit is required to clear this error condition.

**TABLE 4-6: WIPER REGISTER POR STANDARD SETTINGS (DIGITAL)**

Resistance Code	Typical $R_{AB}$ Value	Default POR Wiper Setting	Wiper Code	
			8-bit	7-bit
-502	5.0 k $\Omega$	Mid scale	7Fh	3Fh
-103	10.0 k $\Omega$	Mid scale	7Fh	3Fh
-503	50.0 k $\Omega$	Mid scale	7Fh	3Fh
-104	100.0 k $\Omega$	Mid scale	7Fh	3Fh

#### 4.4.1.1 Write to Invalid (Reserved) Addresses

Any write to a reserved address will be ignored and will generate an error condition. A Start bit is required to clear this error condition.

**TABLE 4-7: MEMORY MAP AND THE SUPPORTED COMMANDS**

Address	Function	Allowed Commands	Disallowed Commands <sup>(1)</sup>	Memory Type
00h	Volatile Wiper 0	Read, Write, Increment, Decrement	—	RAM
01h-03h	Reserved	none	Read, Write, Increment, Decrement	—
04h	Volatile TCON Register	Read, Write	Increment, Decrement	RAM
05h-0Fh	Reserved	none	Read, Write, Increment, Decrement	—

**Note 1:** This command on this address will generate an error condition. A Start bit is required to clear this error condition.

# MCP45HVX1

## 4.4.1.2 Terminal Control (TCON) Registers

The Terminal Control (TCON) Register contains four control bits for wiper 0. [Register 4-1](#) describes each bit of the TCON register.

The state of each resistor network terminal connection is individually controlled. That is, each terminal connection (A, B and W) can be individually connected/disconnected from the resistor network. This allows the system to minimize the currents through the digital potentiometer.

The value that is written to this register will appear on the resistor network terminals when the serial command has completed.

On a POR/BOR, the registers are loaded with FFh, for all terminals connected. The host controller needs to detect the POR/BOR event and then update the volatile TCON register values.

### REGISTER 4-1: TCON0 BITS (1, 2)

R-1	R-1	R-1	R-1	R/W-1	R/W-1	R/W-1	R/W-1
D7	D6	D5	D4	R0HW	R0A	R0W	R0B
bit 7							bit 0

#### Legend:

R = Readable bit	W = Writable bit	U = Unimplemented bit, read as '0'
-n = Value at POR	'1' = Bit is set	'0' = Bit is cleared      x = Bit is unknown

bit 7:4      **D7-D4:** Reserved. Forced to "1"

bit 3      **R0HW:** Resistor 0 Hardware Configuration Control bit  
 This bit forces Resistor 0 into the "shutdown" configuration of the Hardware pin  
 1 = Resistor 0 is NOT forced to the hardware pin "shutdown" configuration  
 0 = Resistor 0 is forced to the hardware pin "shutdown" configuration

bit 2      **R0A:** Resistor 0 Terminal A (P0A pin) Connect Control bit  
 This bit connects/disconnects the Resistor 0 Terminal A to the Resistor 0 Network  
 1 = P0A pin is connected to the Resistor 0 Network  
 0 = P0A pin is disconnected from the Resistor 0 Network

bit 1      **R0W:** Resistor 0 Wiper (P0W pin) Connect Control bit  
 This bit connects/disconnects the Resistor 0 Wiper to the Resistor 0 Network  
 1 = P0W pin is connected to the Resistor 0 Network  
 0 = P0W pin is disconnected from the Resistor 0 Network

bit 0      **R0B:** Resistor 0 Terminal B (P0B pin) Connect Control bit  
 This bit connects/disconnects the Resistor 0 Terminal B to the Resistor 0 Network  
 1 = P0B pin is connected to the Resistor 0 Network  
 0 = P0B pin is disconnected from the Resistor 0 Network

- Note 1:** These bits do not affect the Wiper register values.  
**Note 2:** The hardware SHDN pin (when active) overrides the state of these bits. When the SHDN pin returns to the inactive state, the TCON register will control the state of the terminals. The SHDN pin does not modify the state of the TCON bits.

NOTES:

# MCP45HVX1

## 5.0 RESISTOR NETWORK

The resistor network has either 7-bit or 8-bit resolution. Each resistor network allows zero-scale to full-scale connections. Figure 5-1 shows a block diagram for the resistive network of a device. The resistor network has up to three external connections. These are referred to as Terminal A, Terminal B, and the wiper (or Terminal W).

The resistor network is made up of several parts. These include:

- Resistor Ladder Module
- Wiper
- Shutdown Control (terminal connections)

Terminal A and B as well as the wiper W do not have a polarity. These terminals can support both positive and negative current.



**Note 1:** The wiper resistance is dependent on several factors including wiper code, device V+ voltage, terminal voltages (on A, B and W), and temperature. Also for the same conditions, each tap selection resistance has a small variation. This R<sub>W</sub> variation has greater effect on some specifications (such as INL) for the smaller resistance devices (5.0 kΩ) compared to larger resistance devices (100.0 kΩ).

FIGURE 5-1: Resistor Block Diagram.

## 5.1 Resistor Ladder Module

The R<sub>AB</sub> resistor ladder is composed of the series of equal value Step resistors (R<sub>S</sub>) and the Full-Scale (R<sub>FS</sub>) and Zero-Scale (R<sub>ZS</sub>) resistances:

$$R_{AB} = R_{ZS} + n * R_S + R_{FS}$$

Where “n” is determined by the resolution of the device. The R<sub>FS</sub> and R<sub>ZS</sub> resistances are discussed in Section 5.1.3.

There is a connection point (tap) between each R<sub>S</sub> resistor. Each tap point is a connection point for an analog switch. The opposite side of the analog switch is connected to a common signal which is connected to the Terminal W (wiper) pin (see Section 5.2).

Figure 5-1 shows a block diagram of the Resistor Network. The R<sub>AB</sub> (and R<sub>S</sub>) resistance has small variations over voltage and temperature.

The end points of the resistor ladder are connected to analog switches, which are connected to the device Terminal A and Terminal B pins. In the ideal case, these switches would have 0Ω of resistance, that is R<sub>FS</sub> = R<sub>ZS</sub> = 0Ω. This will also be referred to as the Simplified model.

For an 8-bit device, there are 255 resistors in a string between Terminal A and Terminal B. The wiper can be set to tap onto any of these 255 resistors, thus providing 256 possible settings (including Terminal A and Terminal B). A wiper setting of 00h connects Terminal W (wiper) to Terminal B (zero scale). A wiper setting of 7Fh is the mid-scale setting. A wiper setting of FFh connects Terminal W (wiper) to Terminal A (full scale). Table 5-2 illustrates the full wiper setting map.

For a 7-bit device, there are 127 resistors in a string between Terminal A and Terminal B. The wiper can be set to tap onto any of these 127 resistors, thus providing 128 possible settings (including Terminal A and Terminal B). A wiper setting of 00h connects Terminal W (wiper) to Terminal B (zero scale). A wiper setting of 3Fh is the mid-scale setting. A wiper setting of 7Fh connects the wiper to Terminal A (full scale). Table 5-2 illustrates the full wiper setting map.

### 5.1.1 R<sub>AB</sub> CURRENT (I<sub>RAB</sub>)

The current through the R<sub>AB</sub> resistor (A pin to B pin) is dependent on the voltage on the V<sub>A</sub> and V<sub>B</sub> pins and the R<sub>AB</sub> resistance.

#### EQUATION 5-1: R<sub>AB</sub>

$$R_{AB} = R_{ZS} + (n * R_S) + R_{FS} = \frac{|(V_A - V_B)|}{(I_{RAB})}$$

V<sub>A</sub> is the voltage on the V<sub>A</sub> pin.

V<sub>B</sub> is the voltage on the V<sub>B</sub> pin.

I<sub>RAB</sub> is the current from the P0A pin to the P0B pin.

## 5.1.2 STEP RESISTANCE ( $R_S$ )

Step resistance ( $R_S$ ) is the resistance from one tap setting to the next. This value will be dependent on the  $R_{AB}$  value that has been selected (and the full-scale and zero-scale resistances). The  $R_S$  resistors are manufactured so that they should be very consistent with each other, and track each other's values as voltage and/or temperature change.

Equation 5-2 shows the simplified and detailed equations for calculating the  $R_S$  value. The simplified equation assumes  $R_{FS} = R_{ZS} = 0\Omega$ . Table 5-1 shows example step resistance calculations for each device, and the variation of the detailed model ( $R_{FS} \neq 0\Omega$ ;  $R_{ZS} \neq 0\Omega$ ) from the simplified model ( $R_{FS} = R_{ZS} = 0\Omega$ ). As the  $R_{AB}$  resistance option increases, the effects of the  $R_{ZS}$  and  $R_{FS}$  resistance decreases.

The total resistance of the device has minimal variation due to operating voltage (see device characterization graphs).

Equation 5-2 shows calculations for the step resistance.

## EQUATION 5-2: $R_S$ CALCULATION

**Simplified Model (assumes  $R_{FS} = R_{ZS} = 0\Omega$ )**

$$R_{AB} = (n * R_S)$$

$$R_S = \frac{R_{AB}}{n}$$

**8-bit**

$$R_S = \frac{R_{AB}}{255}$$

**7-bit**

$$R_S = \frac{R_{AB}}{127}$$

**Detailed Model**

$$R_{AB} = R_{FS} + (n * R_S) + R_{ZS}$$

$$R_S = \frac{R_{AB} - R_{FS} - R_{ZS}}{n}$$

or

$$R_S = \frac{(V_{FS} - V_{ZS})}{n I_{AB}}$$

Where:

"n" = 255 (8-bit) or 127 (7-bit)

$V_{FS}$  is the wiper voltage at full-scale code

$V_{ZS}$  is the wiper voltage at zero-scale code

$I_{AB}$  is the current between Terminal A and Terminal B

**TABLE 5-1: EXAMPLE STEP RESISTANCES ( $R_S$ ) CALCULATIONS**

Example Resistance ( $\Omega$ )					Variation % (1)	Resolution	Comment
$R_{AB}$	$R_{ZS}$ (3)	$R_{FS}$ (3)	$R_S$				
			Equation	Value			
5,000	0	0	5,000 / 127	39.37	0	7-bit (127 $R_S$ )	Simplified Model (2)
	80	60	4,860 / 127	38.27	-2.80		
	0	0	5,000 / 255	19.61	0	8-bit (255 $R_S$ )	Simplified Model (2)
	80	60	4,860 / 255	19.06	-2.80		
10,000	0	0	10,000 / 127	78.74	0	7-bit (127 $R_S$ )	Simplified Model (2)
	80	60	9,860 / 127	77.64	-1.40		
	0	0	10,000 / 255	39.22	0	8-bit (255 $R_S$ )	Simplified Model (2)
	80	60	9,860 / 255	38.67	-1.40		
50,000	0	0	50,000 / 127	393.70	0	7-bit (127 $R_S$ )	Simplified Model (2)
	80	60	49,860 / 127	392.60	-0.28		
	0	0	50,000 / 255	196.08	0	8-bit (255 $R_S$ )	Simplified Model (2)
	80	60	49,860 / 255	195.53	-0.28		
100,000	0	0	100,000 / 127	787.40	0	7-bit (127 $R_S$ )	Simplified Model (2)
	80	60	99,860 / 127	786.30	-0.14		
	0	0	100,000 / 255	392.16	0	8-bit (255 $R_S$ )	Simplified Model (2)
	80	60	99,860 / 255	391.61	-0.14		

**Note 1:** Delta % from Simplified Model  $R_S$  calculation value:

**2:** Assumes  $R_{FS} = R_{ZS} = 0\Omega$ .

**3:** Zero-Scale ( $R_{ZS}$ ) and Full-Scale ( $R_{FS}$ ) resistances are dependent on many operational characteristics of the device, including the V+/V- voltage, the voltages on the A, B and W terminals, the wiper code selected, the  $R_{AB}$  resistance, and the temperature of the device.

# MCP45HVX1

## 5.1.3 $R_{FS}$ AND $R_{ZS}$ RESISTORS

The  $R_{FS}$  and  $R_{ZS}$  resistances are artifacts of the  $R_{AB}$  resistor network implementation. In the ideal model, the  $R_{FS}$  and  $R_{ZS}$  resistances would be  $0\Omega$ . These resistors are included in the block diagram to help better model the actual device operation. Equation 5-3 shows how to estimate the  $R_S$ ,  $R_{FS}$ , and  $R_{ZS}$  resistances, based on the measured voltages of  $V_{AB}$ ,  $V_{FS}$ , and  $V_{ZS}$  and the measured current  $I_{AB}$ .

### EQUATION 5-3: ESTIMATING $R_S$ , $R_{FS}$ , AND $R_{ZS}$

$$R_{FS} = \frac{|(V_A - V_{FS})|}{(I_{RAB})}$$

$$R_{ZS} = \frac{|(V_{ZS} - V_B)|}{(I_{RAB})}$$

$$R_S = \frac{V_S}{(I_{RAB})}$$

Where:

$$V_S = \frac{(V_{FS} - V_{ZS})}{255} \quad (8\text{-bit device})$$

$$V_S = \frac{(V_{FS} - V_{ZS})}{127} \quad (7\text{-bit device})$$

$V_{FS}$  is the  $V_W$  voltage when the wiper code is at full scale.

$V_{ZS}$  is the  $V_W$  voltage when the wiper code is at zero scale.

## 5.2 Wiper

The Wiper terminal is connected to an analog switch MUX, where one side of all the analog switches are connected together, the W terminal. The other side of each analog switch is connected to one of the taps of the  $R_{AB}$  resistor string (see Figure 5-1).

The value in the volatile Wiper register selects which analog switch to close, connecting the W terminal to the selected node of the resistor ladder. The Wiper register is 8-bits wide, and Table 5-2 shows the wiper value state for both 7-bit and 8-bit devices.

The wiper resistance ( $R_W$ ) is the resistance of the selected analog switch in the analog MUX. This resistance is dependent on many operational characteristics of the device, including the  $V+/V-$  voltage, the voltages on the A, B and W terminals, the wiper code selected, the  $R_{AB}$  resistance, and the temperature of the device.

When the wiper value is at zero scale (00h), the wiper is connected closest to the B terminal. When the wiper value is at full scale (FFh for 8-bit, 7Fh for 7-bit), the wiper is connected closest to the A terminal.

A zero-scale wiper value connects the W terminal (wiper) to the B terminal (wiper = 00h). A full-scale wiper value connects the W terminal (wiper) to the A terminal (wiper = FFh (8-bit), or wiper = 7Fh (7-bit)). In these configurations, the only resistance between the Terminal W and the other terminal (A or B) is that of the analog switches.

**TABLE 5-2: VOLATILE WIPER VALUE VS. WIPER POSITION**

Wiper Setting		Properties
7-bit	8-bit	
7Fh	FFh	Full Scale (W = A), Increment commands ignored
7Eh-40h	FEh-80h	W = N
3Fh	7Fh	W = N (Mid Scale)
3Eh-01h	7Eh-01h	W = N
00h	00h	Zero Scale (W = B) Decrement command ignored



## 5.2.1 WIPER RESISTANCE ( $R_W$ )

Wiper resistance is significantly dependent on:

- The Resistor Network's Supply Voltage ( $V_{RN}$ )
- The Resistor Network's Terminal (A, B, and W) Voltages
- Switch leakage (occurs at higher temperatures)
- $I_W$  current

Figure 5-2 show the wiper resistance characterization data for all four  $R_{AB}$  resistances and temperatures. Each  $R_{AB}$  resistance determined the maximum wiper current based on worst-case conditions  $R_{AB} = R_{AB}$  maximum and at full-scale code,  $V_{BW} \approx V+$  (but not exceeding  $V+$ ). The  $V+$  targets were 10V, 20V, and 36V. What this graph shows is that at higher  $R_{AB}$  resistances (50 k $\Omega$  and 100 k $\Omega$ ) and at the highest temperature (+125°C), the analog switch leakage causes an increase in the measured result of  $R_W$ , where  $R_W$  is measured in a rheostat configuration with  $R_W = (V_{BW} - V_{BA}) / I_W$ .



**FIGURE 5-2:**  $R_W$  Resistance vs  $R_{AB}$ , Wiper Current ( $I_W$ ), Temperature and Wiper Code.

Since there is minimal variation of the total device resistance ( $R_{AB}$ ) over voltage, at a constant temperature (see device characterization graphs), the change in wiper resistance over voltage can have a significant impact on the  $R_{INL}$  and  $R_{DNL}$  errors.

## 5.2.2 POTENTIOMETER CONFIGURATION

In a potentiometer configuration, the wiper resistance variation does not affect the output voltage seen on the W pin and therefore is not a significant source of error.

## 5.2.3 RHEOSTAT CONFIGURATION

In a rheostat configuration, the wiper resistance variation creates nonlinearity in the  $R_{BW}$  (or  $R_{AW}$ ) value. The lower the nominal resistance ( $R_{AB}$ ), the greater the possible relative error. Also, a change in voltage needs to be taken into account. For the 5.0 k $\Omega$  device, the maximum wiper resistance at 5.5V is approximately 6% of the total resistance, while at 2.7V it is approximately 6.5% of the total resistance.

## 5.2.4 LEVEL SHIFTERS (DIGITAL TO ANALOG)

Since the digital logic may operate anywhere within the analog power range, level shifters are present so that the digital signals control the analog circuitry. This level shifter logic is relative to the  $V-$  and  $V_L$  voltages. A delta voltage of 2.7V between  $V_L$  and  $V-$  is required for the serial interface to operate at the maximum specified frequency.

# MCP45HVX1

## 5.3 Terminal Currents

The terminal currents are limited by several factors, including the  $R_{AB}$  resistance ( $R_S$  resistance). The maximum current occurs when the wiper is at either the zero-scale ( $I_{BW}$ ) or full-scale ( $I_{AW}$ ) code. In this case, the current is only going through the analog switches (see  $I_T$  specification in [Electrical Characteristics](#)). When the current passes through at least one  $R_S$  resistive element, then the maximum terminal current ( $I_T$ ) has a different limit. The current through the  $R_{AB}$  resistor is limited by the  $R_{AB}$  resistance. The worst case (max current) occurs when the resistance is at the minimum  $R_{AB}$  value.

Higher current capabilities allow a greater delta voltage between the desired terminals for a given resistance. This also allows a more usable range of wiper code val-

ues, without violating the maximum terminal current specification. [Table 5-3](#) shows resistance and current calculations based on the  $R_{AB}$  resistance ( $R_S$  resistance) for a system that supports  $\pm 18V$  ( $\Delta 36V$ ). In Rheostat configuration, the minimum wiper code value is shown (for  $V_{BW} = 36V$ ). As the  $V_{BW}$  voltage decreases, the minimum wiper code value also decreases. Using a wiper code less than this value will cause the maximum terminal current ( $I_T$ ) specification to be violated.

**Note:** For high terminal-current applications, it is recommended that proper PCB layout techniques be used to address the thermal implications of this high current. The QFN package has better thermal properties than the TSSOP package.

**TABLE 5-3: TERMINAL (WIPER) CURRENT AND WIPER SETTINGS ( $R_W = R_{FS} = R_{ZS} = 0\Omega$ )**

$R_{AB}$ Resistance ( $\Omega$ )			$R_{S(MIN)}$ ( $\Omega$ )		$I_{AB(MAX)}$ (mA) (= $36V / R_{AB(MIN)}$ ) (1)	$I_T$ (A, B, or W ( $I_W$ )) (mA) ( $I_{BW(W=ZS)}, I_{AW(W=FS)}$ ) (1)	$R_{BW}$ ( $\Omega$ ) (= $36V / I_{T(MAX)}$ ) (2)	Rheostat Min 'N' when $V_{BW} = 36V$ $N * R_{S(MIN)} * 36V < I_T$ (mA) (3)		Rheostat $V_{BW(MAX)}$ When Wiper = 01h (V) (= $I_{T(MAX)} * R_{S(MIN)}$ )	
Typical	Min	Max	8-bit	7-bit				8-bit	7-bit	8-bit	7-bit
5,000	4,000	6,000	15.686	31.496	9.00	25.0	1,440	91	45	0.392	0.787
10,000	8,000	12,000	31.373	62.992	4.50	12.5	2,880	91	45	0.392	0.787
50,000	40,000	60,000	156.863	314.961	0.90	6.5	5539	35	17	1.020	2.047
100,000	80,000	120,000	313.725	629.9	0.45	6.5	5539	17	8	2.039	4.094

**Note 1:**  $I_{BW}$  or  $I_{AW}$  currents can be much higher than this depending on voltage differential between Terminal B and Terminal W or Terminal A and Terminal W.

**2:** Any  $R_{BW}$  resistance greater than this limits the current.

**3:** If  $V_{BW} = 36V$ , then the wiper code value must be greater than or equal to Min 'N'. Wiper codes less than Min 'N' will cause the wiper current ( $I_W$ ) to exceed the specification. Wiper codes greater than Min 'N' will cause the wiper current to be less than the maximum. The Min 'N' number has been rounded up from the calculated number to ensure that the wiper current does not exceed the maximum specification.

Figure 5-3 through Figure 5-6 show a graph of the calculated currents (minimum, typical, and maximum) for each resistor option. These graphs are based on 25 mA (5 kΩ), 12.5 mA (10 kΩ), and 6.5 mA (50 kΩ and 100 kΩ) specifications.

To ensure no damage to the resistor network (including long-term reliability) the maximum terminal current must not be exceeded. This means that the application must assume that the  $R_{AB}$  resistance is the minimum  $R_{AB}$  value ( $R_{AB(MIN)}$ ), see blue lines in graphs).

Looking at the 50 kΩ device, the maximum terminal current is 6.5 mA. That means that any wiper code value greater than 36 ensures that the terminal current is less than 6.5 mA. This is ~14% of the full-scale value. If the application could change to the 100 kΩ device, which has the same maximum terminal current specification, any wiper code value greater than 18 ensures that the terminal current is less than 6.5 mA. This is ~7% of the full-scale value. Supporting higher terminal current allows a greater wiper code range for a given  $V_{BW}$  voltage.



**FIGURE 5-3:** Maximum  $I_{BW}$  vs Wiper Code - 5 kΩ .



**FIGURE 5-4:** Maximum  $I_{BW}$  vs Wiper Code - 10 kΩ .



**FIGURE 5-5:** Maximum  $I_{BW}$  vs Wiper Code - 50 kΩ .

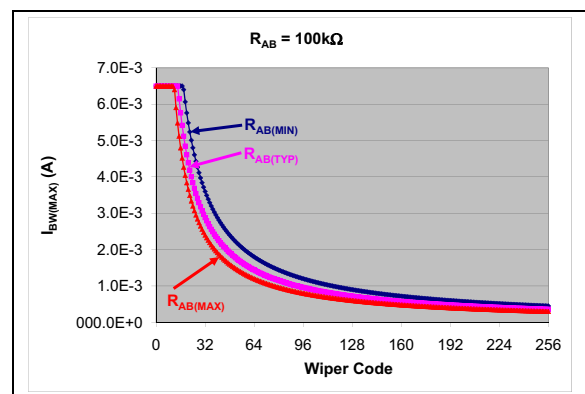

**FIGURE 5-6:** Maximum  $I_{BW}$  vs Wiper Code - 100 kΩ .

Figure 5-7 shows a graph of the maximum  $V_{BW}$  voltage vs wiper code (for 5 kΩ and 10 kΩ devices). To ensure that no damage is done to the resistor network, the  $R_{AB(MIN)}$  resistance (blue line) should be used to determine  $V_{BW}$  voltages for the circuit. Devices where the  $R_{AB}$  resistance is greater than the  $R_{AB(MIN)}$  resistance will naturally support a higher voltage limit.



**FIGURE 5-7:** Maximum  $V_{BW}$  vs Wiper Code (5 kΩ and 10 kΩ devices).

# MCP45HVX1

Table 5-4 shows the maximum  $V_{BW}$  voltage that can be applied across the Terminal B to Terminal W pins for a given wiper code value (for the 5 k $\Omega$  and 10 k $\Omega$  devices). These calculations assume the ideal model ( $R_W = R_{FS} = R_{ZS} = 0\Omega$ ) and show the calculations based on  $R_{S(MIN)}$  and  $R_{S(MAX)}$ . Table 5-5 shows the same calculations for the 50 k $\Omega$  devices, and Table 5-6 shows the calculations for the 100 k $\Omega$  devices. These tables are supplied as a quick reference.

**TABLE 5-4: MAX  $V_{BW}$  AT EACH WIPER CODE ( $R_W = R_{FS} = R_{ZS} = 0\Omega$ ) FOR  $V_+ - V_- = 36V$ , 5 K $\Omega$  AND 10 K $\Omega$  DEVICES**

Code		$V_{BW(MAX)}$		Code		$V_{BW(MAX)}$		Code		$V_{BW(MAX)}$	
Hex	Dec	$R_{S(MIN)}$	$R_{S(MAX)}$	Hex	Dec	$R_{S(MIN)}$	$R_{S(MAX)}$	Hex	Dec	$R_{S(MIN)}$	$R_{S(MAX)}$
00h	0	0.000	0.000	20h	32	12.549	18.824	40h	64	25.098	
01h	1	0.392	0.588	21h	33	12.941	19.412	41h	65	25.490	
02h	2	0.784	1.176	22h	34	13.333	20.000	42h	66	25.882	
03h	3	1.176	1.765	23h	35	13.725	20.588	43h	67	25.275	
04h	4	1.569	2.353	24h	36	14.118	21.176	44h	68	26.667	
05h	5	1.961	2.941	25h	37	14.510	21.765	45h	69	27.059	
06h	6	2.353	3.529	26h	38	14.902	22.353	46h	70	27.451	
07h	7	2.745	4.118	27h	39	15.294	22.941	47h	71	27.843	
08h	8	3.137	4.706	28h	40	15.686	23.529	48h	72	28.235	
09h	9	3.529	5.294	29h	41	16.078	24.118	49h	73	28.627	
0Ah	10	3.922	5.882	2Ah	42	16.471	24.706	4Ah	74	29.020	
0Bh	11	4.314	6.471	2Bh	43	16.863	25.294	4Bh	75	29.412	
0Ch	12	4.706	7.059	2Ch	44	17.255	25.882	4Ch	76	29.804	
0Dh	13	5.098	7.647	2Dh	45	17.647	26.471	4Dh	77	30.196	
0Eh	14	5.490	8.235	2Eh	46	18.039	27.059	4Eh	78	30.588	
0Fh	15	5.882	8.824	2Fh	47	18.431	27.647	4Fh	79	30.980	
10h	16	5.275	9.412	30h	48	18.824	28.235	50h	80	31.373	
11h	17	6.667	10.000	31h	49	19.216	28.824	51h	81	31.765	
12h	18	7.059	10.588	32h	50	19.608	29.412	52h	82	32.157	
13h	19	7.451	11.176	33h	51	20.000	30.000	53h	83	32.549	
14h	20	7.843	11.765	34h	52	20.392	30.588	54h	84	32.941	
15h	21	8.235	12.353	35h	53	20.784	31.176	55h	85	33.333	
16h	22	8.627	12.941	36h	54	21.176	31.765	56h	86	33.725	
17h	23	9.020	13.529	37h	55	21.569	32.353	57h	87	34.118	
18h	24	9.412	14.118	38h	56	21.961	32.941	58h	88	34.510	
19h	25	9.804	14.706	39h	57	22.353	33.529	59h	89	34.902	
1Ah	26	10.196	15.294	3Ah	58	22.745	34.118	5Ah	90	35.294	
1Bh	27	10.588	15.882	3Bh	59	23.137	34.706	5Bh	91	35.686	
1Ch	28	10.980	16.471	3Ch	60	23.529	35.294	5Ch	92 - 255	36.0 (1, 2)	
1Dh	29	11.373	17.059	3Dh	61	23.922	35.882				
1Eh	30	11.765	17.647	3Eh	62	24.314	36.0 (1, 2)				
1Fh	31	12.157	18.235	3Fh	63	24.706					

- Note 1:** Calculated  $R_{BW}$  voltage is greater than 36V (highlighted in color), must be limited to 36V ( $V_+ - V_-$ ).
- Note 2:** This wiper code and greater will limit the  $I_{BW}$  current to less than the maximum supported terminal current ( $I_T$ ).

# MCP45HVX1

**TABLE 5-5: MAX  $V_{BW}$  AT EACH WIPER CODE ( $R_W = R_{FS} = R_{ZS} = 0\Omega$ ) FOR  $V_+ - V_- = 36V$ , 50  $K\Omega$  DEVICES**

Code		$V_{BW(MAX)}$		Code		$V_{BW(MAX)}$		Code		$V_{BW(MAX)}$	
Hex	Dec	$R_{S(MIN)}$	$R_{S(MAX)}$	Hex	Dec	$R_{S(MIN)}$	$R_{S(MAX)}$	Hex	Dec	$R_{S(MIN)}$	$R_{S(MAX)}$
00h	0	0.000	0.000	10h	16	16.314	24.471	20h	32	32.627	
01h	1	1.020	1.529	11h	17	17.333	26.000	21h	33	33.647	
02h	2	2.039	3.059	12h	18	18.353	27.529	22h	34	34.667	
03h	3	3.059	4.588	13h	19	19.373	29.059	23h	35	35.686	
04h	4	4.078	6.118	14h	20	20.392	30.588	24h - FFh	36 - 255	36.0 (1, 2)	
05h	5	5.098	7.647	15h	21	21.412	32.118				
06h	6	6.118	9.176	16h	22	22.431	33.647				
07h	7	7.137	10.706	17h	23	23.451	35.176				
08h	8	8.157	12.235	18h	24	24.471	36.0 (1, 2)				
09h	9	9.176	13.765	19h	25	25.490					
0Ah	10	10.196	15.294	1Ah	26	26.510					
0Bh	11	11.216	16.824	1Bh	27	27.529					
0Ch	12	12.235	18.353	1Ch	28	28.549					
0Dh	13	13.255	19.882	1Dh	29	29.569					
0Eh	14	14.275	21.412	1Eh	30	30.588					
0Fh	15	15.294	22.941	1Fh	31	31.608					

- Note 1:** Calculated  $R_{BW}$  voltage is greater than 36V (highlighted in color), must be limited to 36V ( $V_+ - V_-$ ).  
**Note 2:** This wiper code and greater will limit the  $I_{BW}$  current to less than the maximum supported terminal current ( $I_T$ ).

**TABLE 5-6: MAX  $V_{BW}$  AT EACH WIPER CODE ( $R_W = R_{FS} = R_{ZS} = 0\Omega$ ) FOR  $V_+ - V_- = 36V$ , 100  $K\Omega$  DEVICES**

Code		$V_{BW(MAX)}$		Code		$V_{BW(MAX)}$	
Hex	Dec	$R_{S(MIN)}$	$R_{S(MAX)}$	Hex	Dec	$R_{S(MIN)}$	$R_{S(MAX)}$
00h	0	0.000	0.000	10h	16	32.627	
01h	1	2.039	3.059	11h	17	34.667	
02h	2	4.078	6.118	12h - FFh	18 - 255	36.0 (1, 2)	
03h	3	6.118	9.176				
04h	4	8.157	12.235				
05h	5	10.196	15.294				
06h	6	12.235	18.353				
07h	7	14.275	21.412				
08h	8	16.314	24.471				
09h	9	18.353	27.529				
0Ah	10	20.392	30.588				
0Bh	11	22.431	33.647				
0Ch	12	24.471	36.0 (1, 2)				
0Dh	13	26.510					
0Eh	14	28.549					
0Fh	15	30.588					

- Note 1:** Calculated  $R_{BW}$  voltage is greater than 36V (highlighted in color), must be limited to 36V ( $V_+ - V_-$ ).  
**Note 2:** This wiper code and greater will limit the  $I_{BW}$  current to less than the maximum supported terminal current ( $I_T$ ).

# MCP45HVX1

## 5.4 Variable Resistor (Rheostat)

A variable resistor is created using Terminal W and either Terminal A or Terminal B. Since the wiper code value of 0 connects the wiper to the Terminal B, the  $R_{BW}$  resistance increases with increasing wiper code value. Conversely, the  $R_{AW}$  resistance will decrease with increasing wiper code value. Figure 5-8 shows the connections from a potentiometer to create a rheostat configuration.



**FIGURE 5-8:** Rheostat Configuration.

Equation 5-4 shows the  $R_{BW}$  and  $R_{AW}$  calculations. The  $R_{BW}$  calculation is for the resistance between the wiper and Terminal B. The  $R_{AW}$  calculation is for the resistance between the wiper and Terminal A.

### EQUATION 5-4: $R_{BW}$ AND $R_{AW}$ CALCULATION

**Simplified Model (assumes  $R_{FS} = R_{ZS} = 0\Omega$ )**

$$R_{BW} = (n * R_S)$$

$$R_{AW} = ((FSV - n) * R_S)$$

Where:

$$R_S = \frac{R_{AB}}{\text{Resolution}}$$

$R_S = \frac{R_{AB}}{255}$	$R_S = \frac{R_{AB}}{127}$
8-bit	7-bit

$n$  = wiper code  
 FSV = The full-scale value  
 (255 for 8-bit or 127 for 7-bit)

**Detailed Model**

$$R_{BW} = R_{ZS} + (n * R_S)$$

$$R_{AW} = R_{FS} + ((FSV - n) * R_S)$$

Where:

$n$  = wiper code  
 FSV = The full-scale value  
 (255 for 8-bit or 127 for 7-bit)

## 5.5 Analog Circuitry Power Requirements

This device has two power supplies. One is for the digital interface ( $V_L$  and DGND) and the other is for the high-voltage analog circuitry ( $V+$  and  $V-$ ). The maximum delta voltage between  $V+$  and  $V-$  is 36V. The digital power signals must be between  $V+$  and  $V-$ .

If the digital ground (DGND) pin is at half the potential of  $V+$  (relative to  $V-$ ), then the terminal pins potentials can be  $\pm(V+/2)$  relative to DGND.

Figure 5-9 shows the relationship of the four power signals. This shows that the  $V+/V-$  signals do not need to be symmetric around the DGND signal.

To ensure that the Wiper register has been properly loaded with the POR/BOR value, the  $V_L$  voltage must be at the minimum specified operating voltage (referenced to DGND).



**FIGURE 5-9:** Analog Circuitry Voltage Ranges.

## 5.6 Resistor Characteristics

### 5.6.1 $V+/V-$ LOW VOLTAGE OPERATION

The resistor network is specified from 20V to 36V. At voltages below 20V, the resistor network will function, but the operational characteristics may be outside the specified limits. Please refer to Section 2.0 “Typical Performance Curves” for additional information.

### 5.6.2 RESISTOR TEMP CO

Biasing the ends (Terminal A and Terminal B) near mid-supply  $((V+ - |V-|) / 2)$  will give the worst switch resistance temperature coefficient (tempco).

## 5.7 Shutdown Control

Shutdown is used to minimize the device's current consumption. The MCP45HVX1 has two methods to achieve this:

- **Hardware Shutdown Pin (SHDN)**
- **Terminal Control Register (TCON)**

The Hardware Shutdown pin is backwards compatible with the MCP42X1 devices.

### 5.7.1 HARDWARE SHUTDOWN PIN (SHDN)

The  $\overline{\text{SHDN}}$  pin is available on the potentiometer devices. When the  $\overline{\text{SHDN}}$  pin is forced active ( $V_{IL}$ ):

- The P0A terminal is disconnected
- The P0W terminal is connected to the P0B terminal (see [Figure 4-5](#))
- The Serial Interface is NOT disabled, and all Serial Interface activity is executed

The Hardware Shutdown Pin mode does NOT corrupt the values in the volatile wiper registers nor the TCON register. When the Shutdown mode is exited ( $\overline{\text{SHDN}}$  pin is inactive ( $V_{IH}$ ):

- The device returns to the wiper setting specified by the volatile wiper value
- The TCON register bits return to controlling the terminal connection state



**FIGURE 5-10:** Hardware Shutdown Resistor Network Configuration.

### 5.7.2 TERMINAL CONTROL REGISTER (TCON)

The Terminal Control (TCON) register is a volatile register used to configure the connection of each resistor network terminal pin (A, B and W) to the Resistor Network. This register is shown in [Register 4-1](#).

The R0HW bit forces the selected resistor network into the same state as the  $\overline{\text{SHDN}}$  pin. Alternate low-power configurations may be achieved with the R0A, R0W and R0B bits.

When the R0HW bit is "0":

- The P0A terminal is disconnected
- The P0W terminal is simultaneously connected to the P0B terminal (see [Figure 5-11](#))

**Note:** When the R0HW bit forces the resistor network into the hardware  $\overline{\text{SHDN}}$  state, the state of the TCON0 register's R0A, R0W and R0B bits is overridden (ignored). When the state of the R0HW bit no longer forces the resistor network into the hardware  $\overline{\text{SHDN}}$  state, the TCON0 register's R0A, R0W and R0B bits return to controlling the terminal connection state. In other words, the R0HW bit does not corrupt the state of the R0A, R0W and R0B bits.

The R0HW bit does NOT corrupt the values in the volatile wiper registers nor the TCON register. When the Shutdown mode is exited (R0HW bit = 1):

- The device returns to the wiper setting specified by the volatile wiper value
- The TCON register bits return to controlling the terminal connection state

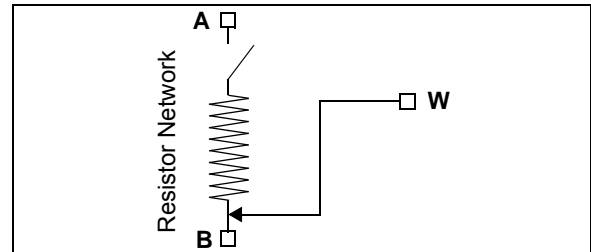

**FIGURE 5-11:** Resistor Network Shutdown State (R0HW = 0).

### 5.7.3 INTERACTION OF $\overline{\text{SHDN}}$ PIN AND TCON REGISTER

[Figure 5-12](#) shows how the  $\overline{\text{SHDN}}$  pin signal and the R0HW bit signal interact to control the hardware shutdown of the resistor network.



**FIGURE 5-12:** R0HW bit and  $\overline{\text{SHDN}}$  pin Interaction.



# MCP45HVX1

## 6.0 SERIAL INTERFACE (I<sup>2</sup>C)

The MCP45HVX1 devices support the I<sup>2</sup>C serial protocol. The MCP45HVX1 I<sup>2</sup>C module operates in Slave mode (does not generate the serial clock). [Figure 6-1](#) shows a typical I<sup>2</sup>C interface connection.

The MCP45HVX1 devices use the two-wire I<sup>2</sup>C serial interface. This interface can operate in Standard, Fast or High-Speed mode. A device that sends data onto the bus is defined as transmitter, and a device receiving data as receiver. The bus has to be controlled by a master device which generates the serial clock (SCL), controls the bus access and generates the Start and Stop conditions. The MCP45HVX1 device works as slave. Both master and slave can operate as transmitter or receiver, but the master device determines which mode is activated. Communication is initiated by the master (microcontroller) which sends the Start bit, followed by the slave address byte. The first byte transmitted is always the slave address byte, which contains the device code, the address bits, and the R/W bit.

Refer to the NXP I<sup>2</sup>C document for more details of the I<sup>2</sup>C specifications (UM10204, Ver. 05 Oct 2012).



**FIGURE 6-1:** Typical I<sup>2</sup>C Interface Block Diagram.

## 6.1 Signal Descriptions

The I<sup>2</sup>C interface uses up to four pins (signals). These are:

- SDA (Serial Data)
- SCL (Serial Clock)
- A0 (Address 0 bit)
- A1 (Address 1 bit)

### 6.1.1 SERIAL DATA (SDA)

The Serial Data (SDA) signal is the data signal of the device. The value on this pin is latched on the rising edge of the SCL signal when the signal is an input.

With the exception of the Start and Stop conditions, the High or Low state of the SDA pin can only change when the clock signal on the SCL pin is Low. During the High period of the clock, the SDA pin's value (High or Low) must be stable. Changes in the SDA pin's value while the SCL pin is High will be interpreted as a Start or a Stop condition.

### 6.1.2 SERIAL CLOCK (SCL)

The Serial Clock (SCL) signal is the clock signal of the device. The rising edge of the SCL signal latches the value on the SDA pin. The MCP45HVX1 supports three I<sup>2</sup>C interface clock modes:

- Standard mode: clock rates up to 100 kHz
- Fast mode: clock rates up to 400 kHz
- High-Speed mode (HS mode): clock rates up to 3.4 MHz

The MCP45HVX1 will not stretch the clock signal (SCL) since memory read access occurs fast enough.

Depending on the clock rate mode, the interface will display different characteristics.

### 6.1.3 THE ADDRESS BITS (A1:A0)

There are up to two hardware pins used to specify the device address. The number of address pins is determined by the part number.

The state of the A0 and A1 pins should be static, that is they should be tied High or tied Low.



## 6.2 I<sup>2</sup>C Operation

The MCP45HVX1 I<sup>2</sup>C module is compatible with the NXP I<sup>2</sup>C specification. The following lists some of the module's features:

- 7-bit slave addressing
- Supports three clock rate modes:
  - Standard mode, clock rates up to 100 kHz
  - Fast mode, clock rates up to 400 kHz
  - High-Speed mode (HS mode), clock rates up to 3.4 MHz
- Support Multi-Master Applications
- General call addressing

The I<sup>2</sup>C 10-bit addressing mode is not supported.

The NXP I<sup>2</sup>C specification only defines the field types, field lengths, timings, etc. of a frame. The frame content defines the behavior of the device. The frame content for the MCP45HVX1 is defined in **Section 7.0**.

### 6.2.1 I<sup>2</sup>C BIT STATES AND SEQUENCE

Figure 6-8 shows the I<sup>2</sup>C transfer sequence. The serial clock is generated by the master. The following definitions are used for the bit states:

- Start bit (S)
- Data bit
- Acknowledge (A) bit (driven Low)  
No Acknowledge ( $\bar{A}$ ) bit (not driven Low)
- Repeated Start bit (Sr)
- Stop bit (P)

#### 6.2.1.1 Start Bit

The Start bit (see Figure 6-2) indicates the beginning of a data transfer sequence. The Start bit is defined as the SDA signal falling when the SCL signal is "High".



FIGURE 6-2: Start Bit.

#### 6.2.1.2 Data Bit

The SDA signal may change state while the SCL signal is Low. While the SCL signal is High, the SDA signal MUST be stable (see Figure 6-3).



FIGURE 6-3: Data Bit.

#### 6.2.1.3 Acknowledge (A) Bit

The A bit (see Figure 6-4) is typically a response from the receiving device to the transmitting device. Depending on the context of the transfer sequence, the A bit may indicate different things. Typically, the slave device will supply an A response after the Start bit and 8 "data" bits have been received. An A bit has the SDA signal Low.

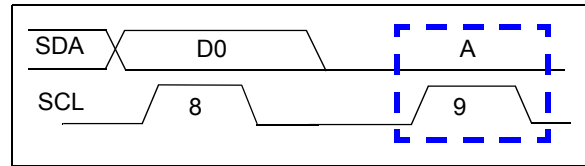

FIGURE 6-4: Acknowledge Waveform.

#### Not A ( $\bar{A}$ ) Response

The  $\bar{A}$  bit has the SDA signal High. Table 6-1 shows some of the conditions where the slave device will issue a Not A ( $\bar{A}$ ).

If an error condition occurs (such as an  $\bar{A}$  instead of A), then a Start bit must be issued to reset the command state machine.

TABLE 6-1: MCP45HVX1  $\bar{A}$ /A RESPONSES

Event	Acknowledge Bit Response	Comment
General Call	A	Only if GCEN bit is set
Slave Address valid	A	
Slave Address not valid	$\bar{A}$	
Device Memory Address and specified command (AD3:AD0 and C1:C0) are an invalid combination	$\bar{A}$	After device has received address and command
Bus Collision	N.A.	I <sup>2</sup> C™ module resets, or a "don't care" if the collision occurs on the master's "Start bit"

# MCP45HVX1

## 6.2.1.4 Repeated Start Bit

The Repeated Start bit (see [Figure 6-5](#)) indicates the current master device will attempt to continue communicating with the current slave device without releasing the I<sup>2</sup>C bus. The Repeated Start condition is the same as the Start condition, except that the Repeated Start bit follows a Start bit (with the Data bits + A bit) and not a Stop bit.

The Start bit is the beginning of a data transfer sequence and is defined as the SDA signal falling when the SCL signal is “High”.

**Note 1:** A bus collision during the Repeated Start condition occurs if:

- SDA is sampled Low when SCL goes from low-to-high.
- SCL goes Low before SDA is asserted Low. This may indicate that another master is attempting to transmit a data ‘1’.



**FIGURE 6-5:** Repeat Start Condition Waveform.

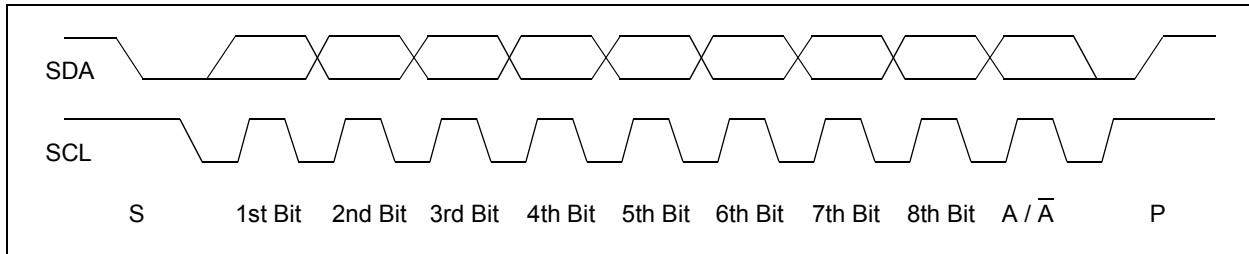

**FIGURE 6-7:** Typical 8-Bit I<sup>2</sup>C Waveform Format.

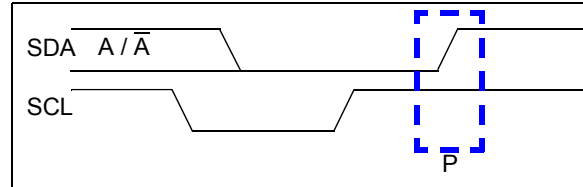

**FIGURE 6-8:** I<sup>2</sup>C Data States and Bit Sequence.

## 6.2.1.5 Stop Bit

The Stop bit (see [Figure 6-6](#)) indicates the end of the I<sup>2</sup>C Data Transfer Sequence. The Stop bit is defined as the SDA signal rising when the SCL signal is “High”.

A Stop bit resets the I<sup>2</sup>C interface of all MCP45HVX1 devices.



**FIGURE 6-6:** Stop Condition Receive or Transmit Mode.

## 6.2.2 CLOCK STRETCHING

“Clock Stretching” is something that the receiving device can do, to allow additional time to “respond” to the “data” that has been received.

The MCP45HVX1 will not stretch the clock signal (SCL) since memory read access occurs fast enough.

## 6.2.3 ABORTING A TRANSMISSION

If any part of the I<sup>2</sup>C transmission does not meet the command format, it is aborted. This can be intentionally accomplished with a Start or Stop condition. This is done so that noisy transmissions (usually an extra Start or Stop condition) are aborted before they corrupt the device.

## 6.2.4 ADDRESSING

The address byte is the first byte received following the Start condition from the master device. The address contains four (or more) fixed bits and (up to) three user-defined hardware address bits (pins A1 and A0). These 7-bits address the desired I<sup>2</sup>C device. The A6:A2 address bits are fixed to '01111' and the device appends the value of following two address pins (A1 and A0).

Since there are address bits controlled by hardware pins, there may be up to four MCP45HVX1 devices on the same I<sup>2</sup>C bus.

Figure 6-9 shows the slave address byte format, which contains the seven address bits. There is also a read/write (R/W) bit. Table 6-2 shows the fixed address for device.

### Hardware Address Pins

The hardware address bits (A1, and A0) correspond to the logic level on the associated address pins. This allows up to four devices on the bus.



**FIGURE 6-9:** Slave Address Bits in the I<sup>2</sup>C Control Byte.

**TABLE 6-2:** DEVICE SLAVE ADDRESSES

Device	Address	Comment
MCP45HVX1	'0111 1'b + A1:A0	Supports up to 4 devices. (Note 1)

**Note 1:** The fixed portion of the I<sup>2</sup>C address is different than the MCP44XX/MCP45XX/MCP46XX family ('0101 11', '0101 1', or '0101'). This allows the maximum number of both standard and high-voltage devices on the single I<sup>2</sup>C bus.

## 6.2.5 SLOPE CONTROL

The MCP45HVX1 implements slope control on the SDA output.

As the device transitions from HS mode to FS mode, the slope control parameter will change from the HS specification to the FS specification.

For Fast (FS) and High-Speed (HS) modes, the device has a spike suppression and a Schmitt trigger at SDA and SCL inputs.

# MCP45HVX1

## 6.2.6 HS MODE

The I<sup>2</sup>C specification requires that a High-Speed mode device must be 'activated' to operate in High-Speed (3.4 Mbit/s) mode. This is done by the master sending a special address byte following the Start bit. This byte is referred to as the High-Speed Master Mode Code (HSMMC).

The MCP45HVX1 device does not acknowledge this byte. However, upon receiving this command, the device switches to HS mode. The device can now communicate at up to 3.4 Mbit/s on SDA and SCL lines. The device will switch out of the HS mode on the next Stop condition.

The master code is sent as follows:

1. Start condition (S)
2. High-Speed Master Mode Code (0000 1xxx), The xxx bits are unique to the High-Speed (HS) mode master.
3. No Acknowledge ( $\bar{A}$ )

After switching to the High-Speed mode, the next transferred byte is the I<sup>2</sup>C control byte, which specifies the device to communicate with, and any number of data bytes plus acknowledgments. The master device can then issue either a Repeated Start bit to address a different device (at high speed) or a Stop bit to return to Fast/Standard bus speed. After the Stop bit, any other master device (in a multi-master system) can arbitrate for the I<sup>2</sup>C bus.

See Figure 6-10 for illustration of HS mode command sequence.

For more information on the HS mode, or other I<sup>2</sup>C modes, please refer to the Phillips I<sup>2</sup>C specification.

### 6.2.6.1 Slope Control

The slope control on the SDA output is different between the Fast/Standard Speed and the High-Speed Clock modes of the interface.

### 6.2.6.2 Pulse Gobbler

The pulse gobbler on the SCL pin is automatically adjusted to suppress spikes < 10 ns during HS mode.



FIGURE 6-10: HS Mode Sequence.

## 6.2.7 GENERAL CALL

The General Call is a method that the “master” device can communicate with all other “slave” devices. In a multi-master application, the other master devices are operating in Slave mode. The General Call address has two documented formats. These are shown in [Figure 6-11](#). We have added an MCP45HVX1 format in this figure as well.

This will allow customers to have multiple I<sup>2</sup>C digital potentiometers on the bus and have them operate in a synchronous fashion (analogous to the DAC Sync pin functionality). If these MCP45HVX1 7-bit commands conflict with other I<sup>2</sup>C devices on the bus, then the customer will need two I<sup>2</sup>C buses and ensure that the devices are on the correct bus for their desired application functionality.

Dual Pot devices can not update both Pot0 and Pot1 from a single command. To address this, there are General Call commands for the Wiper 0, Wiper 1, and the TCON registers.

[Table 6-3](#) shows the General Call commands. Three commands are specified by the I<sup>2</sup>C specification and are not applicable to the MCP45HVX1 (so command is Not Acknowledged) The MCP45HVX1 General Call commands are Acknowledged. Any other command is Not Acknowledged.

**Note:** Only one General Call command per issue of the General Call control byte. Any additional General Call commands are ignored and Not Acknowledged.

**TABLE 6-3: GENERAL CALL COMMANDS**

7-bit Command (1, 2, 3)	Comment
'1000 000'b or '1000 001'b	Write next byte (third byte) to volatile Wiper 0 register
'1100 000'b or '1100 001'b	Write Next Byte (Third Byte) to TCON Register
'1000 010'b or '1000 011'b	Increment Wiper 0 Register
'1000 100'b or '1000 101'b	Decrement Wiper 0 Register

- Note 1:** Any other code is Not Acknowledged. These codes may be used by other devices on the I<sup>2</sup>C bus.
- 2:** The 7-bit command always appends a “0” to form 8-bits.

# MCP45HVX1



**FIGURE 6-11:** General Call Formats.

NOTES:

# MCP45HVX1

## 7.0 DEVICE COMMANDS

The MCP45HVX1's I<sup>2</sup>C command formats are specified in this section. The I<sup>2</sup>C protocol does not specify how commands are formatted.

The MCP45HVX1 supports four basic commands. The location accessed determines the commands that are supported.

For the volatile wiper registers, these commands are:

- Write Data
- Read Data
- Increment Data
- Decrement Data

These commands have formats for both a single command or continuous commands. These commands are shown in [Table 7-1](#).

**TABLE 7-1: I<sup>2</sup>C COMMANDS**

Command		# of Bit Clocks <sup>(1,2)</sup>	Operates on Volatile/ Nonvolatile memory
Operation	Mode		
Write Data	Single	29	Both
	Continuous	18n + 11	Volatile Only
Read Data	Single	29	Both
	Random	48	Both
Increment	Single	20	Volatile Only
	Continuous	9n + 11	Volatile Only
Decrement	Single	20	Volatile Only
	Continuous	9n + 11	Volatile Only

- Note 1:** "n" indicates the number of times the command operation is to be repeated.
- 2:** These clock counts are for "standard" and "fast" I<sup>2</sup>C communication.

[Table 7-2](#) shows the supported commands for each memory location.

[Table 7-3](#) shows an overview of all the device commands and their interaction with other device features.

## 7.1 Command Byte

The MCP45HVX1 command byte has three fields: the address, the command operation, and two data bits (see [Figure 7-1](#)). Currently only one of the data bits is defined (D8).

The device memory is accessed when the master sends a proper command byte to select the desired operation. The memory location getting accessed is contained in the command byte's AD3:AD0 bits. The action desired is contained in the command byte's C1:C0 bits, see [Figure 7-1](#). C1:C0 determines if the desired memory location will be read, written, incremented (wiper setting +1) or decremented (wiper setting -1). The Increment and Decrement commands are only valid on the volatile Wiper register.

If the address bits and command bits are not a valid combination, then the MCP45HVX1 will generate a Not Acknowledge pulse to indicate the invalid combination. The I<sup>2</sup>C master device must then force a Start condition to reset the MCP45HVX1 I<sup>2</sup>C module.

D9 and D8 are unused data bits. These bits maintain code compatibility with the MCP44XX, MCP45XX, and MCP46XX devices.



**FIGURE 7-1: Command Byte Format.**



**TABLE 7-2: MEMORY MAP AND THE SUPPORTED COMMANDS**

Address		Command	Data (10-bits) <sup>(1)</sup>	Comment
Value	Function			
00h	Volatile Wiper 0	Write Data	nn nnnn nnnn	
		Read Data <sup>(3)</sup>	nn nnnn nnnn	
		Increment Wiper	—	
		Decrement Wiper	—	
01h-03h	Reserved	—	—	
04h <sup>(2)</sup>	Volatile TCON 0 Register	Write Data	nn nnnn nnnn	
		Read Data <sup>(3)</sup>	nn nnnn nnnn	
05h-FFh	Reserved	—	—	

- Note 1:** The data memory is 8-bits wide, so the two MSBs are ignored by the device. This is for compatibility with the MCP44XX, MCP45XX, and MCP46XX command formats.
- 2:** Increment or Decrement commands are invalid for these addresses.
- 3:** I<sup>2</sup>C read operation will read two bytes, of which the 8 bits of data are contained within the Least Significant Byte (LSB). This is for compatibility with the MCP44XX, MCP45XX, and MCP46XX command formats.

# MCP45HVX1

## 7.2 Data Byte

Only the Read command and the Write command have data byte(s). Even though only one byte of data is required for the commands, the supported commands will be formatted for compatibility with the MCP44XX, MCP45XX, and MCP46XX command formats with support of 10 bits of data.

## 7.3 Error Condition

If the four address bits received (AD3:AD0) and the two command bits received (C1:C0) are a valid combination, the MCP45HVX1 will Acknowledge the I<sup>2</sup>C bus.

If the address bits and command bits are an invalid combination, then the MCP45HVX1 will Not Acknowledge the I<sup>2</sup>C bus.

Once an error condition has occurred, any following commands are ignored until the I<sup>2</sup>C bus is reset with a Start condition.

### 7.3.1 ABORTING A TRANSMISSION

A Restart or Stop condition in the expected data bit position will abort the current command sequence and data will not be written to the MCP45HVX1.

TABLE 7-3: COMMANDS

Command Name	# of Bit Clocks	
	Single	Continuous <sup>(1)</sup>
Write Data	29	18n + 11
Read Data	29 <sup>(2)</sup>	18n + 11
Increment Wiper	20	9n + 11
Decrement Wiper	20	9n + 11

**Note 1:** "n" indicates the number of times the command operation is to be repeated.

**Note 2:** For a random read (read from any memory location), 40 bit clocks are required.

## 7.4 Write Data

The Write command format, see [Figure 7-2](#), includes the I<sup>2</sup>C control byte, an A bit, the MCP45HVX1 command byte, an A bit, the MCP45HVX1 data byte, an A bit, and a Stop (or Restart) condition. The MCP45HVX1 generates the A /  $\bar{A}$  bits.

A Write command to a volatile memory location changes that location after a properly formatted Write command and the A/ $\bar{A}$  clock have been received.

### 7.4.1 SINGLE WRITE TO VOLATILE MEMORY

Data is written to the MCP45HVX1 after every byte transfer (during the Acknowledge). If a Stop or Restart condition is generated during a data transfer (before the A), the data will not be written to the MCP45HVX1. After the A bit, the master can initiate the next sequence with a Stop or Restart condition.

Refer to [Figure 7-2](#) for the byte write sequence.

### 7.4.2 CONTINUOUS WRITES TO VOLATILE MEMORY

A Continuous Write mode of operation is possible when writing to the volatile memory registers (address 00h and 04h). This Continuous Write mode allows writes without a Stop or Restart condition or repeated transmissions of the I<sup>2</sup>C Control Byte. [Figure 7-3](#) shows the sequence for three continuous writes. The writes do not need to be to the same volatile memory address. The sequence ends with the master sending a Stop or Restart condition.



**FIGURE 7-2:** I<sup>2</sup>C Write Sequence.

# MCP45HVX1



**FIGURE 7-3:** I<sup>2</sup>C Continuous Volatile Wiper Write.

## 7.5 Read Data

The Read command format, see [Figure 7-4](#), includes the Start condition, I<sup>2</sup>C control byte (with R/W bit set to “0”), A bit, MCP45HVX1 command byte, A bit, followed by a Repeated Start bit, I<sup>2</sup>C control byte (with R/W bit set to “1”), and the MCP45HVX1 transmitting the requested data high byte, and A bit, the data low byte, the master generating the  $\bar{A}$ , and Stop condition.

The I<sup>2</sup>C control byte requires the R/W bit equal to a logic one (R/W = 1) to generate a read sequence. The memory location read will be the last address contained in a valid write MCP45HVX1 command byte or address 00h if no write operations have occurred since the device was reset (Power-On Reset or Brown-Out Reset).

**Note:** The MSB (Most Significant Byte) of the 16 read bits is all 0’s to maintain read command format compatibility with the MCP44XX/MCP45XX/MCP46XX families of devices.

### 7.5.1 SINGLE READ

[Figure 7-4](#) shows the waveforms for a single read.

For **single reads** the master sends a Stop or Restart condition after the data byte is sent from the slave.

#### 7.5.1.1 Random Read

[Figure 7-5](#) shows the sequence for a Random Read.

### 7.5.2 CONTINUOUS READS

Continuous reads allows the devices’ memory to be read quickly. Continuous reads are possible to all memory locations.

[Figure 7-6](#) shows the sequence for three continuous reads.

For **continuous reads**, instead of transmitting a Stop or Restart condition after the data transfer, the master reads the next data byte. The sequence ends with the master Not Acknowledging and then sending a Stop or Restart.

### 7.5.3 IGNORING AN I<sup>2</sup>C TRANSMISSION AND “FALLING OFF” THE BUS

The MCP45HVX1 expects to receive complete, valid I<sup>2</sup>C commands, and will assume any command not defined as valid is due to a bus corruption, and will enter a passive High condition on the SDA signal. All signals will be ignored until the next valid Start condition and control byte are received.



**FIGURE 7-4:** I<sup>2</sup>C Read (Last Memory Address Accessed).

# MCP45HVX1



**FIGURE 7-5:** I<sup>2</sup>C Random Read.



**FIGURE 7-6:** I<sup>2</sup>C Continuous Reads.

## 7.6 Increment Wiper

The Increment command provides a quick and easy method to modify the potentiometer's wiper by +1 with minimal overhead. The Increment command will only function on the volatile wiper setting memory locations 00h and 01h. The Increment command to nonvolatile addresses will be ignored and will generate an A.

**Note:** Table 7-4 shows the valid addresses for the Increment Wiper command. Other addresses are invalid.

When executing an Increment command, the volatile wiper setting will be altered from n to n+1 for each Increment command received. The value will increment up to 100h max on 8-bit devices and 80h on 7-bit devices. If multiple Increment commands are received after the value has reached 100h (or 80h), the value will not be incremented further. Table 7-4 shows the Increment command versus the current volatile wiper value.

The Increment command will most commonly be performed on the volatile wiper locations until a desired condition is met. The MCP45HVX1 is responsible for generating the A bits.

Refer to Figure 7-7 for the Increment command sequence. The sequence is terminated by the Stop condition. So when executing a continuous command string, the Increment command can be followed by any other valid command. This means that writes do not need to be to the same volatile memory address.

**Note:** The command sequence can go from an increment to any other valid command for the specified address. Issuing an increment or decrement to a reserved location will cause an error condition (A will be generated).

The advantage of using an Increment command instead of a read-modify-write series of commands is speed and simplicity. The wiper will transition after each command acknowledge when accessing the volatile wiper registers.

**TABLE 7-4: INCREMENT OPERATION VS. VOLATILE WIPER VALUE**

Current Wiper Setting		Wiper (W) Properties	Increment Command Operates?
7-bit Pot	8-bit Pot		
7Fh	FFh	Full Scale (W = A)	No
07Eh 40h	FEh 80	W = N	Yes
3Fh	7Fh	W = N (Mid Scale)	
3Eh 01h	7Eh 01	W = N	Yes
00h	00h	Zero Scale (W = B)	



**FIGURE 7-7:** I<sup>2</sup>C Increment Command Sequence.

# MCP45HVX1

## 7.7 Decrement Wiper

The Decrement command provides a quick and easy method to modify the potentiometer's wiper by -1 with minimal overhead. The Decrement command will only function on the volatile wiper setting memory locations 00h and 01h.

**Note:** Table 7-5 shows the valid addresses for the Decrement Wiper command. Other addresses are invalid.

When executing a Decrement command, the volatile wiper setting will be altered from n to n-1 for each Decrement command received. The value will decrement down to 000h min. If multiple Decrement commands are received after the value has reached 000h, the value will not be decremented further. Table 7-5 shows the Decrement command versus the current volatile wiper value.

The Decrement command will most commonly be performed on the volatile wiper locations until a desired condition is met.

Refer to Figure 7-8 for the Decrement command sequence. The sequence is terminated by the Stop condition. So when executing a continuous command string, the Decrement command can be followed by any other valid command. This means that writes do not need to be to the same volatile memory address.

**Note:** The command sequence can go from a decrement to any other valid command for the specified address.

The advantage of using a Decrement command instead of a read-modify-write series of commands is speed and simplicity. The wiper will transition after each command acknowledge when accessing the volatile wiper registers.

**TABLE 7-5: DECREMENT OPERATION VS. VOLATILE WIPER VALUE**

Current Wiper Setting		Wiper (W) Properties	Decrement Command Operates?
7-bit Pot	8-bit Pot		
7Fh	FFh	Full Scale (W = A)	Yes
7Eh 40h	FEh 80	W = N	Yes
3Fh	7Fh	W = N (Mid Scale)	
3Eh 01h	7Eh 01	W = N	
00h	00h	Zero Scale (W = B)	No



**FIGURE 7-8:** I<sup>2</sup>C Decrement Command Sequence.



NOTES:

# MCP45HVX1

## 8.0 APPLICATIONS EXAMPLES

Digital potentiometers have a multitude of practical uses in modern electronic circuits. The most popular uses include precision calibration of set point thresholds, sensor trimming, LCD bias trimming, audio attenuation, adjustable power supplies, motor control overcurrent trip setting, adjustable gain amplifiers and offset trimming.

### 8.1 Using Shutdown Modes

Figure 8-1 shows a possible application circuit where the independent terminals could be used. Disconnecting the wiper allows the transistor input to be taken to the bias voltage level (disconnecting A and or B may be desired to reduce system current). Disconnecting Terminal A modifies the transistor input by the  $R_{BW}$  rheostat value to the Common B. Disconnecting Terminal B modifies the transistor input by the  $R_{AW}$  rheostat value to the Common A. The Common A and Common B connections could be connected to  $V+$  and  $V-$ .

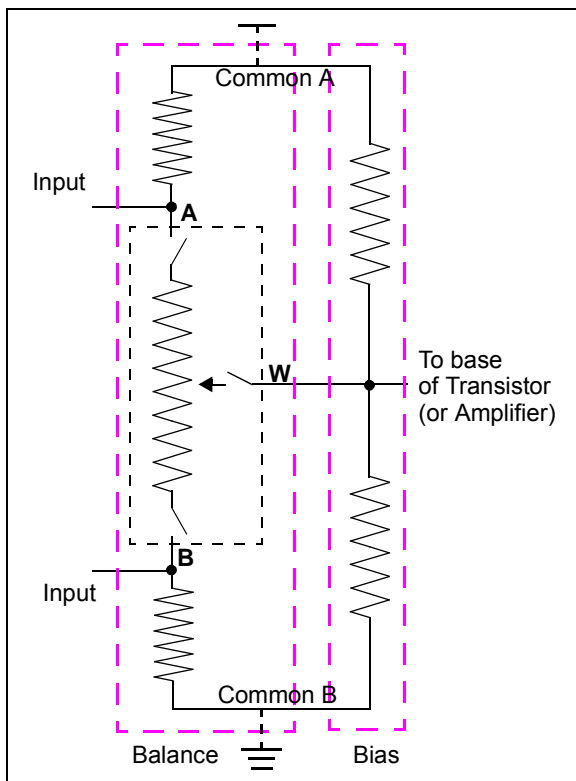

**FIGURE 8-1:** Example Application Circuit using Terminal Disconnects.

## 8.2 Software Reset Sequence

**Note:** This technique is documented in AN1028.

At times, it may become necessary to perform a Software Reset Sequence to ensure the MCP45HVX1 device is in a correct and known I<sup>2</sup>C Interface state. This technique only resets the I<sup>2</sup>C state machine.

This is useful if the MCP45HVX1 device powers-up in an incorrect state (due to excessive bus noise, etc), or if the master device is reset during communication. Figure 8-2 shows the communication sequence to software reset the device.



**FIGURE 8-2:** Software Reset Sequence Format.

The first Start bit will cause the device to reset from a state in which it is expecting to receive data from the master device. In this mode, the device is monitoring the data bus in Receive mode and can detect the Start bit forces an internal Reset.

The nine bits of '1' are used to force a Reset of those devices that could not be reset by the previous Start bit. This occurs only if the MCP45HVX1 is driving an A bit on the I<sup>2</sup>C bus, or is in Output mode (from a Read command) and is driving a data bit of '0' onto the I<sup>2</sup>C bus. In both of these cases, the previous Start bit could not be generated due to the MCP45HVX1 holding the bus Low. By sending out nine '1' bits, it is ensured that the device will see an  $\bar{A}$  bit (the master device does not drive the I<sup>2</sup>C bus Low to acknowledge the data sent by the MCP45HVX1), which also forces the MCP45HVX1 to reset.

The second Start bit is sent to address the rare possibility of an erroneous write. This could occur if the master device was reset while sending a Write command to the MCP45HVX1, and then as the master device returns to normal operation and issues a Start condition while the MCP45HVX1 is issuing an Acknowledge. In this case, if the 2nd Start bit is not sent (and the Stop bit was sent) the MCP45HVX1 could initiate a write cycle.

**Note:** The potential for this erroneous write *only* occurs if the master device is reset while sending a Write command to the MCP45HVX1.

The Stop bit terminates the current I<sup>2</sup>C bus activity. The MCP45HVX1 waits to detect the next Start condition.

This sequence does not effect any other I<sup>2</sup>C devices which may be on the bus, as they should disregard this as an invalid command.

## 8.3 High-Voltage DAC

A high-voltage DAC can be implemented using the MCP45HVX1, with voltages as high as 36V. The circuit is shown in Figure 8-3. The equation to calculate the voltage output is shown in Equation 8-1.



FIGURE 8-3: High-Voltage DAC.

### EQUATION 8-1: DAC OUTPUT VOLTAGE CALCULATION

#### 8-bit

$$V_{OUT}(N) = \frac{N}{255} \times \left( V_D \times \left( 1 + \frac{R1}{R2} \right) \right)$$

N = 0 to 255 (decimal)

#### 7-bit

$$V_{OUT}(N) = \frac{N}{127} \times \left( V_D \times \left( 1 + \frac{R1}{R2} \right) \right)$$

N = 0 to 127 (decimal)

## 8.4 Variable Gain Instrumentation Amplifier

A variable gain instrumentation amplifier can be implemented using the MCP45HVX1 along with a high-voltage dual analog switch and a high-voltage instrumentation amplifier.

Figure 8-3. The equation to calculate the voltage output is shown in Equation 8-2.



FIGURE 8-4: Variable Gain Instrumentation Amplifier for Data Acquisition System.

### EQUATION 8-2: DAC OUTPUT VOLTAGE CALCULATION

#### 8-bit

$$\text{Gain}(N) = 1 + \frac{49.4 \text{ k}\Omega}{(N / 255) \times R_{AB}}$$

N = 0 to 255 (decimal)

#### 7-bit

$$\text{Gain}(N) = 1 + \frac{49.4 \text{ k}\Omega}{(N / 127) \times R_{AB}}$$

N = 0 to 127 (decimal)

# MCP45HVX1

## 8.5 Audio Volume Control

A digital volume control can be implemented with the MCP45HVX1. [Figure 8-5](#) shows a simple audio volume control implementation.

[Figure 8-6](#) shows a circuit-referenced voltage detect circuit. The output of this circuit could be used to control the Wiper Latch of the MCP45HVX1 device in the Audio Volume control circuit to reduce zipper noise or to update the different channels at the same time.

The op amp (U1) could be an MCP6001, while the general purpose comparators (U2 and U3) could be an MCP6541. U4 is a simple AND gate.

U1 establishes the signal zero reference. The upper limit of the comparator is set above its offset. The WLAT pin is forced High whenever the voltage falls between 2.502V and 2.497V (a 0.005V window).

The capacitor C1 AC couples the  $V_{IN}$  signal into the circuit, before feeding into the windowed comparator (and MCP45HVX1 Terminal A pin).



**FIGURE 8-5:** Audio Volume Control.



**FIGURE 8-6:** Referenced Voltage Crossing Detect.

## 8.6 Programmable Power Supply

The ADP1611 is a step-up DC-to-DC switching converter. Using the MCP45HVX1 device allows the power supply to be programmable up to 20V. [Figure 8-7](#) shows a programmable power supply implementation.

[Equation 8-3](#) shows the equation to calculate the output voltage of the programmable power supply. This output is derived from the  $R_{BW}$  resistance of the MCP45HVX1 device and the  $R_2$  resistor. The ADP1611 will adjust its output voltage to maintain 1.23V on the FB pin.

When power is connected, L1 acts as a short, and  $V_{OUT}$  is a diode drop below the +5V voltage. The  $V_{OUT}$  voltage will ramp to the programmed value.



**FIGURE 8-7:** Programmable Power Supply.

### EQUATION 8-3: POWER SUPPLY OUTPUT VOLTAGE CALCULATION

**8-bit**

$$V_{OUT(N)} = 1.23V \times \left( 1 + \left( \frac{N * R_{AB}}{255} \right) \frac{1}{R_2} \right)$$

N = 0 to 255 (decimal)

**7-bit**

$$V_{OUT(N)} = 1.23V \times \left( 1 + \left( \frac{N * R_{AB}}{127} \right) \frac{1}{R_2} \right)$$

N = 0 to 127 (decimal)

## 8.7 Programmable Bidirectional Current Source

A programmable bidirectional current source can be implemented with the MCP45HVX1. Figure 8-8 shows an implementation where U1 and U2 work together to deliver the desired current (dependent on selected device) in both directions. The circuit is symmetrical ( $R_{1A} = R_{1B}$ ,  $R_{2A} = R_{2B}$ ,  $R_{3A} = R_{3B}$ ) in order to improve stability. If the resistors are matched, the load current ( $I_L$ ) calculation is shown below:

### EQUATION 8-4: LOAD CURRENT ( $I_L$ )

$$I_L = \frac{(R_{2A} + R_{3A})}{R_{1A} * R_{3A}} \times V_W$$

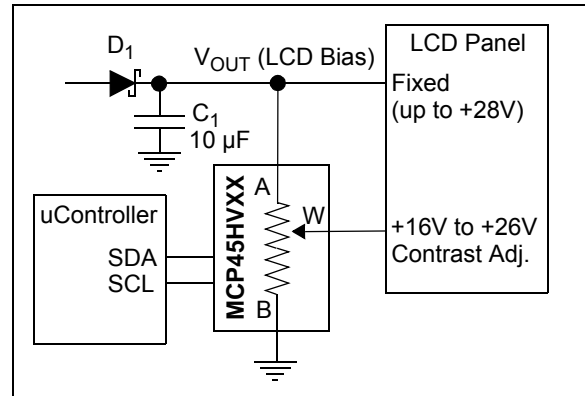

**FIGURE 8-8:** Programmable Bidirectional Current Source.

## 8.8 LCD Contrast Control

The MCP45HVX1 can be used for LCD contrast control. Figure 8-9 shows a simple programmable LCD contrast control implementation.

Some LCD panels support a fixed power supply of up to 28V. The high-voltage digital potentiometer's wiper can support contrast adjustments through the entire voltage range.



**FIGURE 8-9:** Programmable Contrast Control.

# MCP45HVX1

## 8.9 Implementing Log Steps with a Linear Digital Potentiometer

In audio volume control applications, the use of logarithmic steps is desirable since the human ear hears in a logarithmic manner. The use of a linear potentiometer can approximate a log potentiometer, but with fewer steps. An 8-bit potentiometer can achieve fourteen 3 dB log steps plus a 100% (0 dB) and a mute setting.

Figure 8-10 shows a block diagram of one of the MCP45HVX1 resistor networks being used to attenuate an input signal. In this case, the attenuation will be ground referenced. Terminal B can be connected to a Common mode voltage, but the voltages on the A, B and wiper terminals must not exceed the MCP45HVX1's V+/V- voltage limits.



**FIGURE 8-10:** Signal Attenuation Block Diagram – Ground Referenced.

Equation 8-5 shows the equation to calculate voltage dB gain ratios for the digital potentiometer, while Equation 8-6 shows the equation to calculate resistance dB gain ratios. These two equations assume that the B terminal is connected to ground.

If Terminal B is not directly resistively connected to ground, then this Terminal B to ground resistance ( $R_{B2GND}$ ) must be included into the calculation. Equation 8-7 shows this equation.

### EQUATION 8-5: dB CALCULATIONS (VOLTAGE)

$$L = 20 * \log_{10} (V_{OUT} / V_{IN})$$

dB	$V_{OUT} / V_{IN}$ Ratio
-3	0.70795
-2	0.79433
-1	0.89125

### EQUATION 8-6: dB CALCULATIONS (RESISTANCE) – CASE 1

Terminal B connected to Ground (see Figure 8-10)

$$L = 20 * \log_{10} (R_{BW} / R_{AB})$$

### EQUATION 8-7: dB CALCULATIONS (RESISTANCE) – CASE 2

Terminal B through  $R_{B2GND}$  to Ground

$$L = 20 * \log_{10} ( (R_{BW} + R_{B2GND}) / (R_{AB} + R_{B2GND}) )$$

Table 8-1 shows the codes that can be used for 8-bit digital potentiometers to implement the log attenuation. The table shows the wiper codes for -3 dB, -2 dB, and -1 dB attenuation steps. This table also shows the calculated attenuation based on the wiper code's linear step. Calculated attenuation values less than the desired attenuation are shown with red text. At lower wiper code values, the attenuation may skip a step. If this occurs, the next attenuation value is colored magenta to highlight that a skip occurred. For example, in the -3 dB column the -48 dB value is highlighted since the -45 dB step could not be implemented (there are no wiper codes between 2 and 1).

**TABLE 8-1: LINEAR TO LOG ATTENUATION FOR 8-BIT DIGITAL POTENTIOMETERS**

# of Steps	-3 dB Steps			-2 dB Steps			-1 dB Steps		
	Desired Attenuation	Wiper Code	Calculated Attenuation (1)	Desired Attenuation	Wiper Code	Calculated Attenuation (1)	Desired Attenuation	Wiper Code	Calculated Attenuation (1)
0	0 dB	255	0 dB	0 dB	255	0 dB	0 dB	255	0 dB
1	-3 dB	180	-3.025 dB	-2 dB	203	-1.981 dB	-1 dB	227	-1.010 dB
2	-6 dB	128	-5.987 dB	-4 dB	161	-3.994 dB	-2 dB	203	-1.981 dB
3	-9dB	90	-9.046 dB	-6 dB	128	-5.987 dB	-3 dB	180	-3.025 dB
4	-12 dB	64	-12.007 dB	-8 dB	101	-8.044 dB	-4 dB	161	-3.994 dB
5	-15 dB	45	-15.067 dB	-10 dB	81	-9.961 dB	-5 dB	143	-5.024 dB
6	-18 dB	32	-18.028 dB	-12 dB	64	-12.007 dB	-6 dB	128	-5.987 dB
7	-21 dB	23	-20.896 dB	-14 dB	51	-13.979 dB	-7 dB	114	-6.993 dB
8	-24 dB	16	-24.048 dB	-16 dB	40	-16.090 dB	-8 dB	101	-8.044 dB
9	-27 dB	11	-27.303 dB	-18 dB	32	-18.028 dB	-9 dB	90	-9.046 dB
10	-30 dB	8	-30.069 dB	-20 dB	25	-20.172 dB	-10 dB	81	-9.961 dB
11	-33 dB	6	-32.568 dB	-22 dB	20	-22.110 dB	-11 dB	72	-10.984 dB
12	-36 dB	4	-36.090 dB	-24 dB	16	-24.048 dB	-12 dB	64	-12.007 dB
13	-39 dB	3	-38.588 dB	-26 dB	13	-25.852 dB	-13 dB	57	-13.013 dB
14	-42 dB	2	-42.110 dB	-28 dB	10	-28.131 dB	-14 dB	51	-13.979 dB
15	-48 dB	1	-48.131 dB	-30 dB	8	-30.069 dB	-15 dB	45	-15.067 dB
16	Mute	0	Mute	-32 dB	6	-32.602 dB	-16 dB	40	-16.090 dB
17				-34 dB	5	-34.151 dB	-17 dB	36	-17.005 dB
18				-36 dB	4	-36.090 dB	-18 dB	32	-18.028 dB
19				-38 dB	3	-38.588 dB	-19 dB	29	-18.883 dB
20				-42 dB	2	-42.110 dB	-20 dB	25	-20.172 dB
21				-48 dB	1	-48.131 dB	-21 dB	23	-20.896 dB
22				Mute	0	Mute	-22 dB	20	-22.110 dB
23							-23 dB	18	-23.025 dB
24							-24 dB	16	-24.048 dB
25							-25 dB	14	-25.208 dB
26							-26 dB	13	-25.852 dB
27							-27dB	11	-27.303 dB
28							-28 dB	10	-28.131 dB
29							-29 dB	9	-29.046 dB
30							-30 dB	8	-30.069 dB
31							-31 dB	7	-31.229 dB
32							-33 dB	6	-32.568 dB
33							-34 dB	5	-34.151 dB
34							-36 dB	4	-36.090 dB
35							-39 dB	3	-38.588 dB
36							-42 dB	2	-42.110 dB
37							-48 dB	1	-48.131 dB
38							Mute	0	Mute

**Legend:** Calculated Attenuation Value Color Code: **Black** -> Above Target Value; **Red** -> Below Target Value  
 Desired Attenuation Value Color Code: **Magenta** -> Skipped Desired Attenuation Value(s).

**Note 1:** Attenuation values do not include errors from digital potentiometer errors, such as Full-Scale Error or Zero-Scale Error.

# MCP45HVX1

## 8.10 Using the General Call Command

The use of the General Call Address Increment, Decrement, or Write commands is analogous to the “Load” feature (LDAC pin) on some DACs (such as the MCP4921). This allows all the devices to “Update” the output level “at the same time”.

For some applications, the ability to update the wiper values “at the same time” may be a requirement, since the delay from writing to one wiper value and then the next may cause application issues. A possible example would be a “tuned” circuit that uses several MCP45HVX1 in rheostat configuration. As the system condition changes (temperature, load, etc.) these devices need to be changed (incremented/decremented) to adjust for the system change. These changes will either be in the same direction or in opposite directions. With the Potentiometer device, the customer can either select the PxB terminals (same direction) or the PxA terminal(s) (opposite direction).

Figure 8-12 shows that the update of six devices takes  $6 \cdot T_{I2CDLY}$  time in “normal” operation, but only  $1 \cdot T_{I2CDLY}$  time in “General Call” operation.

**Note:** The application system may need to partition the I<sup>2</sup>C bus into multiple buses to ensure that the MCP45HVX1 General Call commands do not conflict with the General Call commands that the other I<sup>2</sup>C devices may have defined. Also, if only a portion of the MCP45HVX1 devices are to require this synchronous operation, then the devices that should not receive these commands should be on the second I<sup>2</sup>C bus.

Figure 8-11 shows two I<sup>2</sup>C bus configurations. In many cases, the single I<sup>2</sup>C bus configuration will be adequate. For applications that do not want all the MCP45HVX1 devices to do General Call support or have a conflict with General Call commands, the multiple I<sup>2</sup>C bus configuration would be used.

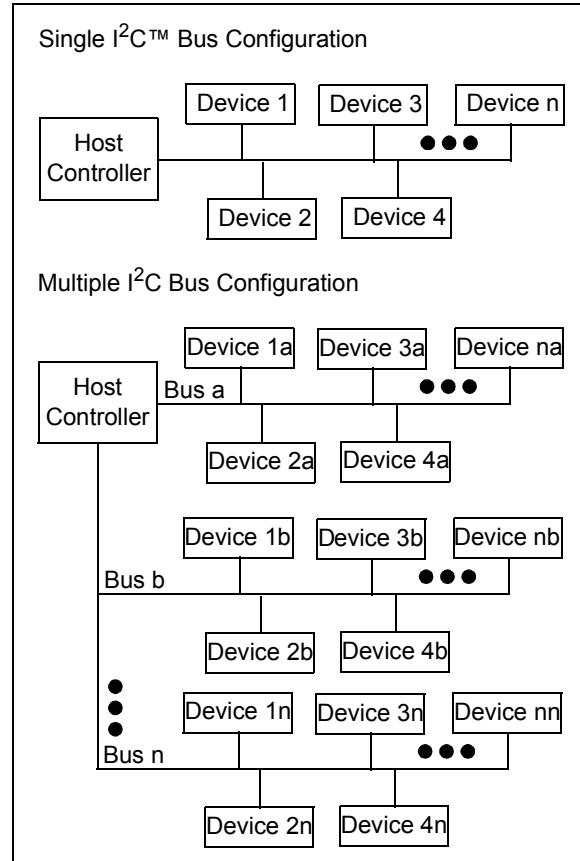

**FIGURE 8-11:** Typical Application I<sup>2</sup>C Bus Configurations.

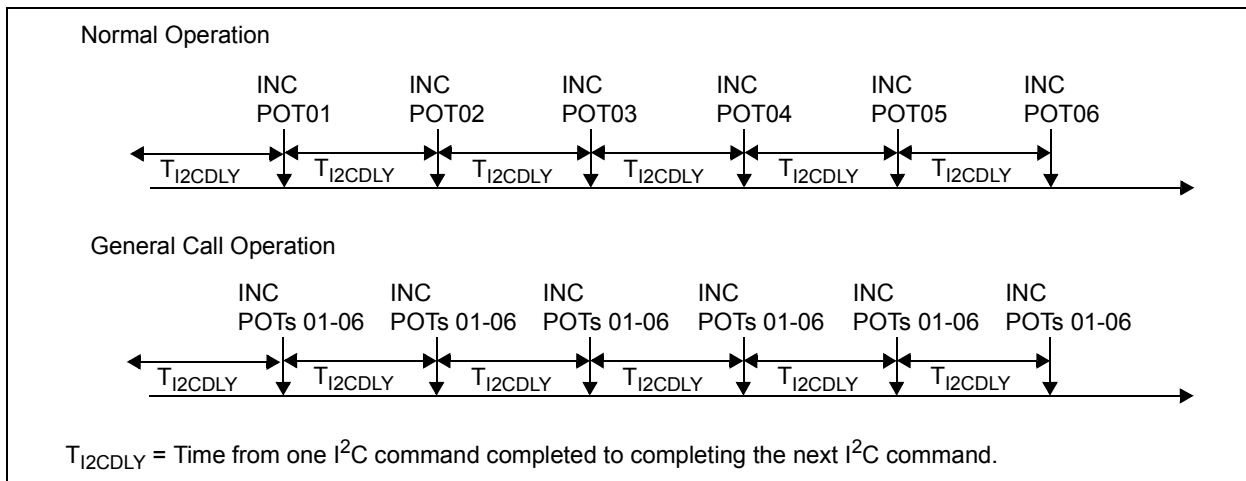

**FIGURE 8-12:** Example Comparison of “Normal Operation” vs. “General Call Operation” Wiper Updates.



## 8.11 Design Considerations

In the design of a system with the MCP45HVX1 devices, the following considerations should be taken into account:

- **Power Supply Considerations**
- **Layout Considerations**

### 8.11.1 POWER SUPPLY CONSIDERATIONS

The typical application will require a bypass capacitor in order to filter high-frequency noise, which can be induced onto the power supply's traces. The bypass capacitor helps to minimize the effect of these noise sources on signal integrity. [Figure 8-13](#) illustrates an appropriate bypass strategy.

In this example, the recommended bypass capacitor value is 0.1  $\mu\text{F}$ . This capacitor should be placed as close (within 4 mm) to the device power pin ( $V_L$ ) as possible.

The power source supplying these devices should be as clean as possible. If the application circuit has separate digital and analog power supplies,  $V_+$  and  $V_-$  should reside on the analog plane.



**FIGURE 8-13:** Typical Microcontroller Connections.

### 8.11.2 LAYOUT CONSIDERATIONS

In the design of a system with the MCP45HVX1 devices, the following layout considerations should be taken into account:

- **Noise**
- **PCB Area Requirements**
- **Power Dissipation**

#### 8.11.2.1 Noise

Inductively-coupled AC transients and digital switching noise can degrade the input and output signal integrity, potentially masking the MCP45HVX1's performance. Careful board layout minimizes these effects and increases the Signal-to-Noise Ratio (SNR). Multi-layer boards utilizing a low-inductance ground plane, isolated inputs, isolated outputs and proper decoupling are critical to achieving the performance that the silicon is capable of providing. Particularly harsh environments may require shielding of critical signals.

If low noise is desired, breadboards and wire-wrapped boards are not recommended.

#### 8.11.2.2 PCB Area Requirements

In some applications, PCB area is a criteria for device selection. [Table 8-2](#) shows the package dimensions and area for the different package options. The table also shows the relative area factor compared to the smallest area. For space critical applications, the QFN package would be the suggested package.

**TABLE 8-2: PACKAGE FOOTPRINT <sup>(1)</sup>**

Package			Package Footprint			
Pins	Type	Code	Dimensions (mm)		Area (mm <sup>2</sup> )	Relative Area
			X	Y		
14	TSSOP	ST	5.10	6.40	32.64	1.31
20	QFN	MQ	5.00	5.00	25.00	1

**Note 1:** Does not include recommended land pattern dimensions.

# MCP45HVX1

## 8.11.3 RESISTOR TEMPCO

Characterization curves of the resistor temperature coefficient (tempco) are shown in the device characterization graphs.

These curves show that the resistor network is designed to correct for the change in resistance as temperature increases. This technique reduces the end-to-end change in  $R_{AB}$  resistance.

### 8.11.3.1 Power Dissipation

The power dissipation of the high-voltage digital potentiometer will most likely be determined by the power dissipation through the resistor networks.

Table 8-3 shows the power dissipation through the resistor ladder ( $R_{AB}$ ) when Terminal A = +18V and Terminal B = -18V. This is not the worst-case power dissipation based on the 25 mA terminal current specification. Table 8-3 shows the worst-case current (per resistor network), which is independent of the  $R_{AB}$  value).

**TABLE 8-3:  $R_{AB}$  POWER DISSIPATION**

$R_{AB}$ Resistance ( $\Omega$ )			$ V_A  +  V_B $ = (V)	Power (mW) <sup>(1)</sup>
Typical	Min	Max		
5,000	4,000	6,000	36	324
10,000	8,000	12,000	36	162
50,000	40,000	60,000	36	32.4
100,000	80,000	120,000	36	16.2

**Note 1:** Power =  $V * I = V^2/R_{AB(MIN)}$ .

**TABLE 8-4:  $R_{BW}$  POWER DISSIPATION**

$R_{AB}$ ( $\Omega$ ) (Typical)	$ V_W  +  V_B $ = (V)	$I_{BW}$ (2) (mA)	Power (mW) <sup>(1)</sup>
5,000	36	25	900
10,000	36	12.5	450
50,000	36	6.5	234
100,000	36	6.5	234

**Note 1:** Power =  $V * I$ .

**2:** See Electrical Specifications (max  $I_W$ ).

NOTES:

# MCP45HVX1

## 9.0 DEVICE OPTIONS

### 9.1 Standard Options

#### 9.1.1 POR/BOR WIPER SETTING

The default wiper setting (mid scale) is indicated by the customer in three digit suffix: -202, -502, -103 and -503. [Table 9-1](#) indicates the device's default settings.

**TABLE 9-1: DEFAULT POR/BOR WIPER SETTING SELECTION**

Typical $R_{AB}$ Value	Package Code	Default POR Wiper Setting	Device Resolution	Wiper Code
5.0 k $\Omega$	-502	Mid scale	8-bit	7Fh
			7-bit	3Fh
10.0 k $\Omega$	-103	Mid scale	8-bit	7Fh
			7-bit	3Fh
50.0 k $\Omega$	-503	Mid scale	8-bit	7Fh
			7-bit	3Fh
100.0 k $\Omega$	-104	Mid scale	8-bit	7Fh
			7-bit	3Fh

## 9.2 Custom Options

Custom options can be made available.

### 9.2.1 CUSTOM WIPER VALUE ON POR/BOR EVENT

Customers can specify a custom wiper setting via the Non-Standard Customer Authorization Request (NSCAR) process.

**Note 1:** Non-Recurring Engineering (NRE) charges and minimum ordering requirements for custom orders. Please contact Microchip sales for additional information.

**2:** A custom device will be assigned custom device marking.

NOTES:

# MCP45HVX1

## 10.0 DEVELOPMENT SUPPORT

### 10.1 Development Tools

Several development tools are available to assist in your design and evaluation of the MCP45HVX1 devices. The currently available tools are shown in [Table 10-1](#).

[Figure 10-1](#) shows how the TSSOP20EV bond-out PCB can be populated to easily evaluate the MCP45HVX1 devices. Evaluation can use the PICKit™ Serial Analyzer to control the position of the volatile wiper and state of the TCON register.

[Figure 10-2](#) shows how the SOIC14EV bond-out PCB can be populated to evaluate the MCP45HVX1 devices. The use of the PICKit Serial Analyzer would require blue wire since the header H1 is not compatibly connected.

These boards may be purchased directly from the Microchip web site at [www.microchip.com](http://www.microchip.com).

## 10.2 Technical Documentation

Several additional technical documents are available to assist you in your design and development. These technical documents include Application Notes, Technical Briefs and Design Guides. [Table 10-2](#) shows some of these documents.

**TABLE 10-1: DEVELOPMENT TOOLS**

Board Name	Part #	Comment
20-pin TSSOP and SSOP Evaluation Board	TSSOP20EV	Can easily interface to PICKit™ Serial Analyzer (Order #: DV164122)
14-pin SOIC/TSSOP/DIP Evaluation Board	SOIC14EV	

**TABLE 10-2: TECHNICAL DOCUMENTATION**

Application Note Number	Title	Literature #
TB3073	Implementing a 10-bit Digital Potentiometer with an 8-bit Digital Potentiometer	DS93073
AN1316	Using Digital Potentiometers for Programmable Amplifier Gain	DS01316
AN1080	Understanding Digital Potentiometers Resistor Variations	DS01080
AN737	Using Digital Potentiometers to Design Low-Pass Adjustable Filters	DS00737
AN692	Using a Digital Potentiometer to Optimize a Precision Single Supply Photo Detect	DS00692
AN691	Optimizing the Digital Potentiometer in Precision Circuits	DS00691
AN219	Comparing Digital Potentiometers to Mechanical Potentiometers	DS00219
—	Digital Potentiometer Design Guide	DS22017
—	Signal Chain Design Guide	DS21825
—	Analog Solutions for Automotive Applications Design Guide	DS01005



**FIGURE 10-1:** Digital Potentiometer Evaluation Board Circuit Using TSSOP20EV.

# MCP45HVX1



FIGURE 10-2: Digital Potentiometer Evaluation Board Circuit Using SOIC14EV.



NOTES:

# MCP45HVX1

## 11.0 PACKAGING INFORMATION

### 11.1 Package Marking Information

14-Lead TSSOP (4.4 mm)



Example

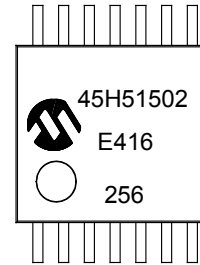

Part Number	Code	Part Number	Code
MCP45HV51-502E/ST	45H51502	MCP45HV31-502E/ST	45H31502
MCP45HV51-103E/ST	45H51103	MCP45HV31-103E/ST	45H31103
MCP45HV51-503E/ST	45H51503	MCP45HV31-503E/ST	45H31503
MCP45HV51-104E/ST	45H51104	MCP45HV31-104E/ST	45H31104

20-Lead QFN (5x5x0.9 mm)

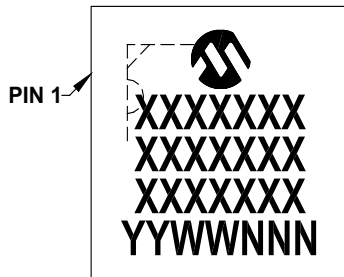

Example

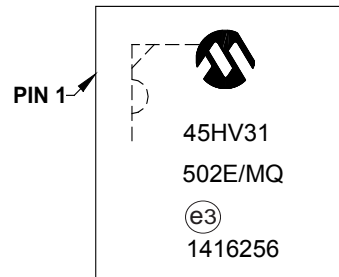

Part Number	Code	Part Number	Code
MCP45HV51-502E/MQ	502E/MQ	MCP45HV31-502E/MQ	502E/MQ
MCP45HV51-103E/MQ	103E/MQ	MCP45HV31-103E/MQ	103E/MQ
MCP45HV51-503E/MQ	503E/MQ	MCP45HV31-503E/MQ	503E/MQ
MCP45HV51-104E/MQ	104E/MQ	MCP45HV31-104E/MQ	104E/MQ

<b>Legend:</b>	XX...X	Customer-specific information
	Y	Year code (last digit of calendar year)
	YY	Year code (last 2 digits of calendar year)
	WW	Week code (week of January 1 is week '01')
	NNN	Alphanumeric traceability code
	(e3)	RoHS Compliant JEDEC® designator for Matte Tin (Sn)
	*	This package is RoHS Compliant. The RoHS Compliant JEDEC designator (e3) can be found on the outer packaging for this package.

**Note:** In the event the full Microchip part number cannot be marked on one line, it will be carried over to the next line, thus limiting the number of available characters for customer-specific information.

## 14-Lead Plastic Thin Shrink Small Outline (ST) - 4.4 mm Body [TSSOP]

**Note:** For the most current package drawings, please see the Microchip Packaging Specification located at <http://www.microchip.com/packaging>



Microchip Technology Drawing C04-087C Sheet 1 of 2

# MCP45HVX1

## 14-Lead Plastic Thin Shrink Small Outline (ST) - 4.4 mm Body [TSSOP]

**Note:** For the most current package drawings, please see the Microchip Packaging Specification located at <http://www.microchip.com/packaging>



Dimension Limits	Units	MILLIMETERS		
		MIN	NOM	MAX
Number of Pins	N	14		
Pitch	e	0.65 BSC		
Overall Height	A	-	-	1.20
Molded Package Thickness	A2	0.80	1.00	1.05
Standoff	A1	0.05	-	0.15
Overall Width	E	6.40 BSC		
Molded Package Width	E1	4.30	4.40	4.50
Molded Package Length	D	4.90	5.00	5.10
Foot Length	L	0.45	0.60	0.75
Footprint	(L1)	1.00 REF		
Foot Angle	$\varphi$	0°	-	8°
Lead Thickness	c	0.09	-	0.20
Lead Width	b	0.19	-	0.30

**Notes:**

1. Pin 1 visual index feature may vary, but must be located within the hatched area.
2. Dimensions D and E1 do not include mold flash or protrusions. Mold flash or protrusions shall not exceed 0.15mm per side.
3. Dimensioning and tolerancing per ASME Y14.5M

BSC: Basic Dimension. Theoretically exact value shown without tolerances.

REF: Reference Dimension, usually without tolerance, for information purposes only.

Microchip Technology Drawing No. C04-087C Sheet 2 of 2

## 14-Lead Plastic Thin Shrink Small Outline (ST) - 4.4 mm Body [TSSOP]

**Note:** For the most current package drawings, please see the Microchip Packaging Specification located at <http://www.microchip.com/packaging>



RECOMMENDED LAND PATTERN

Dimension Limits	Units	MILLIMETERS		
		MIN	NOM	MAX
Contact Pitch	E	0.65 BSC		
Contact Pad Spacing	C1		5.90	
Contact Pad Width (X14)	X1			0.45
Contact Pad Length (X14)	Y1			1.45
Distance Between Pads	G	0.20		

Notes:

1. Dimensioning and tolerancing per ASME Y14.5M

BSC: Basic Dimension. Theoretically exact value shown without tolerances.

Microchip Technology Drawing No. C04-2087A

# MCP45HVX1

## 20-Lead Plastic Quad Flat, No Lead Package (MQ) – 5x5x0.9 mm Body [QFN]

**Note:** For the most current package drawings, please see the Microchip Packaging Specification located at <http://www.microchip.com/packaging>



Dimension Limits	Units	MILLIMETERS		
		MIN	NOM	MAX
Number of Pins	N	20		
Pitch	e	0.65 BSC		
Overall Height	A	0.80	0.90	1.00
Standoff	A1	0.00	0.02	0.05
Contact Thickness	A3	0.20 REF		
Overall Width	E	5.00 BSC		
Exposed Pad Width	E2	3.15	3.25	3.35
Overall Length	D	5.00 BSC		
Exposed Pad Length	D2	3.15	3.25	3.35
Contact Width	b	0.25	0.30	0.35
Contact Length	L	0.35	0.40	0.45
Contact-to-Exposed Pad	K	0.20	-	-

**Notes:**

1. Pin 1 visual index feature may vary, but must be located within the hatched area.
2. Package is saw singulated.
3. Dimensioning and tolerancing per ASME Y14.5M.

BSC: Basic Dimension. Theoretically exact value shown without tolerances.

REF: Reference Dimension, usually without tolerance, for information purposes only.

Microchip Technology Drawing C04-139B

# MCP45HVX1

20-Lead Plastic Quad Flat, No Lead Package (MQ) - 5x5 mm Body [QFN]  
With 0.40mm Contact Length

**Note:** For the most current package drawings, please see the Microchip Packaging Specification located at <http://www.microchip.com/packaging>



RECOMMENDED LAND PATTERN

Dimension Limits	Units	MILLIMETERS		
		MIN	NOM	MAX
Contact Pitch	E	0.65 BSC		
Optional Center Pad Width	W2			3.35
Optional Center Pad Length	T2			3.35
Contact Pad Spacing	C1		4.50	
Contact Pad Spacing	C2		4.50	
Contact Pad Width (X20)	X1			0.40
Contact Pad Length (X20)	Y1			0.55
Distance Between Pads	G	0.20		

Notes:

1. Dimensioning and tolerancing per ASME Y14.5M

BSC: Basic Dimension. Theoretically exact value shown without tolerances.

Microchip Technology Drawing No. C04-2139A

# MCP45HVX1

---



## APPENDIX A: REVISION HISTORY

### Revision A (June 2014)

- Original Release of this Document.

## APPENDIX B: TERMINOLOGY

This appendix discusses the terminology used in this document and it also describes how a parameter is measured.

### B.1 Potentiometer (Voltage Divider)

The potentiometer configuration is when all three terminals of the device are tied to different nodes in the circuit. This allows the potentiometer to output a voltage proportional to the input voltage. This configuration is sometimes called Voltage Divider mode. The potentiometer is used to provide a variable voltage by adjusting the wiper position between the two endpoints as shown in Figure B-1. Reversing the polarity of the A and B terminals will not affect operation.



**FIGURE B-1: POTENTIOMETER CONFIGURATION.**

The temperature coefficient of the  $R_{AB}$  resistors is minimal by design. In this configuration, the resistors all change uniformly, so minimal variation should be seen.

### B.2 Rheostat (Variable Resistor)

The rheostat configuration is when two of the three digital potentiometer's terminals are used as a resistive element in the circuit. With Terminal W (wiper) and either Terminal A or Terminal B, a variable resistor is created. The resistance will depend on the tap setting of the wiper (and the wiper's resistance). The resistance is controlled by changing the wiper setting. Figure B-2 shows the two possible resistors that can be used. Reversing the polarity of the A and B terminals will not affect operation.



**FIGURE B-2: RHEOSTAT CONFIGURATION.**

# MCP45HVX1

## B.3 Resolution

The resolution is the number of wiper output states that divide the full-scale range. For the 8-bit digital potentiometer, the resolution is  $2^8$ , meaning the digital potentiometer wiper code ranges from 0 to 255.

## B.4 Step Resistance ( $R_S$ )

The resistance Step size ( $R_S$ ) equates to one LSB of the resistor ladder. Equation B-1 shows the calculation for the step resistance ( $R_S$ ).

### EQUATION B-1: $R_S$ CALCULATION

$$R_{S(Ideal)} = \frac{R_{AB}}{2^N - 1} \quad \text{or} \quad \frac{(V_A - V_B) / I_{AB}}{2^N - 1}$$

#### Measured

$$R_{S(Measured)} = \frac{(V_{W(@FS)} - V_{W(@ZS)}) / I_{AB}}{2^N - 1}$$

where:

$$2^N - 1 = 255 \text{ (MCP45HV51/61)} \\ = 127 \text{ (MCP45HV31/41)}$$

$V_A$  = Voltage on Terminal A pin

$V_B$  = Voltage on Terminal B pin

$I_{AB}$  = Measured Current through A and B pins

$V_{W(@FS)}$  = Measured Voltage on W pin at Full-Scale code (FFh or 7Fh)

$V_{W(@ZS)}$  = Measured Voltage on W pin at Zero-Scale code (00h)

## B.5 Wiper Resistance

Wiper resistance is the series resistance of the analog switch that connects the selected resistor ladder node to the Wiper terminal common signal (see Figure 5-1).

A value in the volatile Wiper register selects which analog switch to close, connecting the W terminal to the selected node of the resistor ladder.

The resistance is dependent on the voltages on the analog switch source, gate, and drain nodes, as well as the device's wiper code, temperature, and the current through the switch. As the device voltage decreases, the wiper resistance increases.

The wiper resistance is measured by forcing a current through the W and B terminals ( $I_{WB}$ ) and measuring the voltage on the W and A terminals ( $V_W$  and  $V_A$ ). Terminal A is not biased. Equation B-2 shows how to calculate this resistance.

### EQUATION B-2: $R_W$ CALCULATION

$$R_{W(Measured)} = \frac{(V_W - V_A)}{I_{WB}}$$

where:

$V_A$  = Voltage on Terminal A pin

$V_W$  = Voltage on Terminal W pin

$I_{WB}$  = Measured current through W and B pins

The wiper resistance in potentiometer-generated voltage divider applications is not a significant source of error (it does not affect the output voltage seen on the W pin).

The wiper resistance in rheostat applications can create significant nonlinearity as the wiper is moved toward zero scale (00h). The lower the nominal resistance, the greater the possible error.

## B.6 $R_{ZS}$ Resistance

The analog switch between the resistor ladder and the Terminal B pin introduces a resistance, which we call the Zero-Scale resistance ( $R_{ZS}$ ). Equation B-3 shows how to calculate this resistance.

### EQUATION B-3: $R_{ZS}$ CALCULATION

$$R_{ZS(Measured)} = \frac{(V_{W(@ZS)} - V_B)}{I_{AB}}$$

where:

$V_{W(@ZS)}$  = Voltage on Terminal W pin at Zero-Scale wiper code

$V_B$  = Voltage on Terminal B pin

$I_{WB}$  = Measured Current through A and B pins

## B.7 $R_{FS}$ Resistance

The analog switch between the resistor ladder and the Terminal A pin introduces a resistance, which we call the Full-Scale resistance ( $R_{FS}$ ). Equation B-4 shows how to calculate this resistance.

### EQUATION B-4: $R_{FS}$ CALCULATION

$$R_{FS(Measured)} = \frac{(V_A - V_{W(@FS)})}{I_{AB}}$$

where:

$V_A$  = Voltage on Terminal A pin

$V_{W(@FS)}$  = Voltage on Terminal W pin at Full-Scale wiper code

$I_{WB}$  = Measured Current through A and B pins

## B.8 Least Significant Bit (LSb)

This is the difference between two successive codes (either in resistance or voltage). For a given output range it is divided by the resolution of the device (Equation B-5).

### EQUATION B-5: LSb CALCULATION

<b>Ideal</b>	<i>In Resistance</i>	<i>In Voltage</i>
$LSb(Ideal) =$	$\frac{R_{AB}}{2^N - 1}$	$\frac{V_A - V_B}{2^N - 1}$
<b>Measured</b>		
$LSb(Measured) =$	$\frac{(V_{W(@FS)} - V_{W(@ZS)}) / I_{AB}}{2^N - 1}$	
	$\frac{V_{W(@FS)} - V_{W(@ZS)}}{2^N - 1}$	

where:

- $2^N - 1 = 255$  (MCP45HV51)
- $= 127$  (MCP45HV31)
- $V_A$  = Voltage on Terminal A pin
- $V_B$  = Voltage on Terminal B pin
- $V_{AB}$  = Measured Voltage between A and B pins
- $I_{AB}$  = Measured Current through A and B pins
- $V_{W(@FS)}$  = Measured Voltage on W pin at Full-Scale code (FFh or 7Fh)
- $V_{W(@ZS)}$  = Measured Voltage on W pin at Zero-Scale code (00h)

## B.9 Monotonic Operation

Monotonic operation means that the device's output (resistance ( $R_{BW}$ ) or voltage ( $V_W$ )) increases with every one code step (LSb) increment of the Wiper register.



**FIGURE B-3: THEORETICAL  $V_W$  OUTPUT VS CODE (MONOTONIC OPERATION).**



**FIGURE B-4: THEORETICAL  $R_{BW}$  OUTPUT VS CODE (MONOTONIC OPERATION).**

# MCP45HVX1

## B.10 Full-Scale Error ( $E_{FS}$ )

The Full-Scale Error (see [Figure B-5](#)) is the error of the  $V_W$  pin relative to the expected  $V_W$  voltage (theoretical) for the maximum device wiper register code (code FFh for 8-bit and code 7Fh for 7-bit), see [Equation B-6](#). The error is defined with no resistive load on the P0W pin.

The error in bits is determined by the theoretical voltage step size to give an error in LSb.

**Note:** Analog switch leakage increases with temperature. This leakage increases substantially at higher temperatures (> ~100°C). As analog switch leakage increases, the full-scale output value decreases, which increases the Full-Scale Error.

### EQUATION B-6: FULL-SCALE ERROR

$$E_{FS} = \frac{V_{W(@FS)} - V_A}{V_{LSb(IDEAL)}}$$

Where:  
 $E_{FS}$  is expressed in LSb  
 $V_{W(@FS)}$  is the  $V_W$  voltage when the Wiper register code is at Full-scale.  
 $V_{IDEAL(@FS)}$  is the ideal output voltage when the Wiper register code is at Full-scale.  
 $V_{LSb(IDEAL)}$  is the theoretical voltage step size.



**FIGURE B-5: FULL-SCALE ERROR EXAMPLE.**

## B.11 Zero-Scale Error ( $E_{ZS}$ )

The Zero-Scale Error (see [Figure B-6](#)) is the difference between the ideal and measured  $V_{OUT}$  voltage with the Wiper register code equal to 00h ([Equation B-7](#)). The error is defined with no resistive load on the P0W pin.

The error in bits is determined by the theoretical voltage step size to give an error in LSb.

**Note:** Analog switch leakage increases with temperature. This leakage increases substantially at higher temperatures (> ~100°C). As analog switch leakage increases the zero-scale output value decreases, which decreases the Zero-Scale Error.

### EQUATION B-7: ZERO SCALE ERROR

$$E_{ZS} = \frac{V_{W@ZS}}{V_{LSb(IDEAL)}}$$

Where:  
 $E_{ZS}$  is expressed in LSb  
 $V_{W@ZS}$  is the  $V_W$  voltage when the Wiper register code is at Zero-scale.  
 $V_{LSb(IDEAL)}$  is the theoretical voltage step size.



**FIGURE B-6: ZERO-SCALE ERROR EXAMPLE.**

## B.12 Integral Nonlinearity (P-INL) Potentiometer Configuration

The Potentiometer Integral nonlinearity (P-INL) error is the maximum deviation of an actual  $V_W$  transfer function from an ideal transfer function (straight line).

In the MCP45HVX1, P-INL is calculated using the zero-scale and full-scale wiper code end points. P-INL is expressed in LSb. P-INL is also called relative accuracy. Equation B-8 shows how to calculate the P-INL error in LSb and Figure B-7 shows an example of P-INL accuracy.

Positive P-INL means higher  $V_W$  voltage than ideal. Negative P-INL means lower  $V_W$  voltage than ideal.

**Note:** Analog switch leakage increases with temperature. This leakage increases substantially at higher temperatures (> ~100°C). As analog switch leakage increases, the Wiper output voltage ( $V_W$ ) decreases, which affects the INL Error.

### EQUATION B-8: P-INL ERROR

$$E_{INL} = \frac{(V_{W(@Code)} - (V_{LSb(Measured)} * Code))}{V_{LSb(Measured)}}$$

Where:

INL is expressed in LSb.

Code = Wiper Register Value

$V_{W(@Code)}$  = The measured  $V_W$  output voltage with a given Wiper register code

$V_{LSb}$  = For Ideal:  
 $V_{AB} / \text{Resolution}$   
 For Measured:  
 $(V_{W(@FS)} - V_{W(@ZS)}) / 255$



**FIGURE B-7: P-INL ACCURACY.**

## B.13 Differential Nonlinearity (P-DNL) Potentiometer Configuration

The Potentiometer Differential nonlinearity (P-DNL) error (see Figure B-8) is the measure of  $V_W$  step size between codes. The ideal step size between codes is 1 LSb. A P-DNL error of zero would imply that every code is exactly 1 LSb wide. If the P-DNL error is less than 1 LSb, the digital potentiometer guarantees monotonic output and no missing codes. The P-DNL error between any two adjacent codes is calculated in Equation B-9.

P-DNL error is the measure of variations in code widths from the ideal code width.

**Note:** Analog switch leakage increases with temperature. This leakage increases substantially at higher temperatures (> ~100°C). As analog switch leakage increases, the Wiper output voltage ( $V_W$ ) decreases, which affects the DNL Error.

### EQUATION B-9: P-DNL ERROR

$$E_{DNL} = \frac{(V_{W(code = n+1)} - V_{W(code = n)}) - V_{LSb(Measured)}}{V_{LSb(Measured)}}$$

Where:

DNL is expressed in LSb.

$V_{W(Code = n)}$  = The measured  $V_W$  output voltage with a given Wiper register code.

$V_{LSb}$  = For Ideal:  
 $V_{AB} / \text{Resolution}$   
 For Measured:  
 $(V_{W(@FS)} - V_{W(@ZS)}) / \# \text{ of } R_S$



**FIGURE B-8: P-DNL ACCURACY.**

# MCP45HVX1

## B.14 Integral Nonlinearity (R-INL) Rheostat Configuration

The Rheostat Integral nonlinearity (R-INL) error is the maximum deviation of an actual  $R_{BW}$  transfer function from an ideal transfer function (straight line).

In the MCP45HVX1, INL is calculated using the Zero-Scale and Full-Scale wiper code end points. R-INL is expressed in LSB. R-INL is also called relative accuracy. Equation B-10 shows how to calculate the R-INL error in LSB and Figure B-9 shows an example of R-INL accuracy.

Positive R-INL means higher  $V_{OUT}$  voltage than ideal. Negative R-INL means lower  $V_{OUT}$  voltage than ideal.

### EQUATION B-10: R-INL ERROR

$$E_{INL} = \frac{(R_{BW(@code)} - R_{BW(Ideal)})}{R_{LSb(Ideal)}}$$

Where:  
 INL is expressed in LSB.  
 $R_{BW(Code = n)}$  = The measured  $R_{BW}$  resistance with a given wiper register code  
 $R_{LSb}$  = For Ideal:  
                    $R_{AB} / \text{Resolution}$   
                   For Measured:  
                    $R_{BW(@FS)} / \# \text{ of } R_S$



FIGURE B-9: R-INL ACCURACY.

## B.15 Differential Nonlinearity (R-DNL) Rheostat Configuration

The Rheostat Differential nonlinearity (R-DNL) error (see Figure B-10) is the measure of  $R_{BW}$  step size between codes in actual transfer function. The ideal step size between codes is 1 LSB. A R-DNL error of zero would imply that every code is exactly 1 LSB wide. If the R-DNL error is less than 1 LSB, the  $R_{BW}$  Resistance guarantees monotonic output and no missing codes. The R-DNL error between any two adjacent codes is calculated in Equation B-11.

R-DNL error is the measure of variations in code widths from the ideal code width. A R-DNL error of zero would imply that every code is exactly 1 LSB wide.

### EQUATION B-11: R-DNL ERROR

$$E_{DNL} = \frac{(R_{BW(code = n+1)} - R_{BW(code = n)}) - R_{LSb(Measured)}}{R_{LSb(Measured)}}$$

Where:  
 DNL is expressed in LSB.  
 $R_{BW(Code = n)}$  = The measured  $R_{BW}$  resistance with a given wiper register code  
 $R_{LSb}$  = For Ideal:  
                    $R_{AB} / \text{Resolution}$   
                   For Measured:  
                    $R_{BW(@FS)} / \# \text{ of } R_S$



FIGURE B-10: R-DNL ACCURACY.

## B.16 Total Unadjusted Error ( $E_T$ )

The Total Unadjusted Error ( $E_T$ ) is the difference between the ideal and measured  $V_W$  voltage. Typically, calibration of the output voltage is implemented to improve system performance.

The error in bits is determined by the theoretical voltage step size to give an error in LSb.

Equation B-12 shows the Total Unadjusted Error calculation.

**Note:** Analog switch leakage increases with temperature. This leakage increases substantially at higher temperatures (> ~100°C). As analog switch leakage increases, the Wiper output voltage ( $V_W$ ) decreases, which affects the Total Unadjusted Error.

### EQUATION B-12: TOTAL UNADJUSTED ERROR CALCULATION

$$E_T = \frac{(V_{W\_Actual}(@code) - V_{W\_Ideal}(@Code))}{V_{LSb(Ideal)}}$$

Where:

$E_T$  is expressed in LSb.

$V_{W\_Actual}(@code)$  = The measured W pin output voltage at the specified code

$V_{W\_Ideal}(@code)$  = The calculated W pin output voltage at the specified code (code \*  $V_{LSb(Ideal)}$ )

$$V_{LSb(Ideal)} = \frac{V_{AB}}{\# R_S}$$

$$8-bit = \frac{V_{AB}}{255}$$

$$7-bit = \frac{V_{AB}}{127}$$

## B.17 Settling Time

The settling time is the time delay required for the  $V_W$  voltage to settle into its new output value. This time is measured from the start of code transition, to when the  $V_W$  voltage is within the specified accuracy. It is related to the RC characteristics of the resistor ladder and wiper switches.

In the MCP45HVX1, the settling time is a measure of the time delay until the  $V_W$  voltage reaches within 0.5 LSb of its final value, when the volatile Wiper register changes from zero scale to full scale (or full scale to zero scale).

## B.18 Major-Code Transition Glitch

Major-code transition glitch is the impulse energy injected into the wiper pin when the code in the Wiper register changes state. It is normally specified as the area of the glitch in nV-Sec, and is measured when the digital code is changed by 1 LSb at the major carry transition (Example: 01111111 to 10000000, or 10000000 to 01111111).

## B.19 Digital Feedthrough

The digital feedthrough is the glitch that appears at the analog output caused by coupling from the digital input pins of the device. The area of the glitch is expressed in nV-Sec, and is measured with a full-scale change (Example: all 0s to all 1s and vice versa) on the digital input pins. The digital feedthrough is measured when the digital potentiometer is not being written to the output register.

## B.20 Power-Supply Sensitivity (PSS)

PSS indicates how the output ( $V_W$  or  $R_{BW}$ ) of the digital potentiometer is affected by changes in the supply voltage. PSS is the ratio of the change in  $V_W$  to a change in  $V_L$  for mid-scale output of the digital potentiometer. The  $V_W$  is measured while the  $V_L$  is varied from 5.5V to 2.7V as a step, and expressed in %/%, which is the % change of the  $V_W$  output voltage with respect to the % change of the  $V_L$  voltage.

### EQUATION B-13: PSS CALCULATION

$$PSS = \frac{(V_{W(@5.5V)} - V_{W(@2.7V)}) / V_{W(@5.5V)}}{(5.5V - 2.7V) / 5.5V}$$

Where:

PSS is expressed in %/ %.

$V_{W(@5.5V)}$  = The measured  $V_W$  output voltage with  $V_L = 5.5V$

$V_{W(@2.7V)}$  = The measured  $V_W$  output voltage with  $V_L = 2.7V$

## B.21 Power-Supply Rejection Ratio (PSRR)

PSRR indicates how the output of the digital potentiometer is affected by changes in the supply voltage. PSRR is the ratio of the change in  $V_W$  to a change in  $V_L$  for full-scale output of the digital potentiometer. The  $V_W$  is measured while the  $V_L$  is varied +/- 10% ( $V_A$  and  $V_B$  voltages held constant), and expressed in dB or  $\mu V/V$ .

# MCP45HVX1

---

## B.22 Ratiometric Temperature Coefficient

The ratiometric temperature coefficient quantifies the error in the ratio  $R_{AW}/R_{WB}$  due to temperature drift. This is typically the critical error when using a digital potentiometer in a voltage divider configuration.

## B.23 Absolute Temperature Coefficient

The absolute temperature coefficient quantifies the error in the end-to-end resistance (Nominal resistance  $R_{AB}$ ) due to temperature drift. This is typically the critical error when using the device in an adjustable resistor configuration.

Characterization curves of the resistor temperature coefficient (tempco) are shown in [Section 2.0 “Typical Performance Curves”](#).

## B.24 -3dB Bandwidth

This is the frequency of the signal at the A terminal, that causes the voltage at the W pin to be -3dB from its expected value, based on its wiper code. The expected value is determined by the static voltage value on the A terminal and the wiper code value.

## B.25 Resistor Noise Density ( $e_{N\_WB}$ )

This is the random noise generated by the device's internal resistances. It is specified as a spectral density (voltage per square root Hertz).



## PRODUCT IDENTIFICATION SYSTEM

To order or obtain information, e.g., on pricing or delivery, refer to the factory or the listed sales office.

<u>PART NO.</u>	<u>X1<sup>(1)</sup></u>	<u>XXX</u>	<u>X</u>	<u>XX</u>	
Device	Tape and Reel Option	Resistance Version	Temperature Range	Package	
<b>Device:</b>	MCP45HV31:	Single Potentiometer (7-bit) with I <sup>2</sup> C™ Interface			
	MCP45HV51:	Single Potentiometer (8-bit) with I <sup>2</sup> C Interface			
<b>Tape and Reel Option:</b>	T = Tape and Reel <sup>(1)</sup> "blank" = Tube				
<b>Resistance Version:</b>	502 = 5 kΩ 103 = 10 kΩ 503 = 50 kΩ 104 = 100 kΩ				
<b>Temperature Range:</b>	E = -40°C to +125°C				
<b>Package:</b>	ST = Plastic TSSOP-14, 14-lead MQ = Plastic QFN-20 (5x5), 20-lead				

<b>Examples:</b>	
a)	MCP45HV51T-502E/ST 5 kΩ, 8-bit, 14-LD TSSOP
b)	MCP45HV51T-103E/ST 10 kΩ, 8-bit, 14-LD TSSOP
c)	MCP45HV31T-503E/ST 50 kΩ, 7-bit, 14-LD TSSOP
d)	MCP45HV31T-104E/MQ 100 kΩ, 7-bit, 20-LD QFN (5x5)
a)	MCP45HV51T-502E/MQ 5 kΩ, 8-bit, 20-LD QFN (5x5)
b)	MCP45HV51T-103E/MQ 10 kΩ, 8-bit, 20-LD QFN (5x5)
c)	MCP45HV31T-503E/MQ 50 kΩ, 7-bit, 20-LD QFN (5x5)
d)	MCP45HV31T-104E/MQ 100 kΩ, 7-bit, 20-LD QFN (5x5)

**Note 1:** Tape and Reel identifier only appears in the catalog part number description. This identifier is used for ordering purposes and is not printed on the device package. Check with your Microchip Sales Office for package availability with the Tape and Reel option.

# MCP45HVX1

---

NOTES:

---

**Note the following details of the code protection feature on Microchip devices:**

- Microchip products meet the specification contained in their particular Microchip Data Sheet.
- Microchip believes that its family of products is one of the most secure families of its kind on the market today, when used in the intended manner and under normal conditions.
- There are dishonest and possibly illegal methods used to breach the code protection feature. All of these methods, to our knowledge, require using the Microchip products in a manner outside the operating specifications contained in Microchip's Data Sheets. Most likely, the person doing so is engaged in theft of intellectual property.
- Microchip is willing to work with the customer who is concerned about the integrity of their code.
- Neither Microchip nor any other semiconductor manufacturer can guarantee the security of their code. Code protection does not mean that we are guaranteeing the product as “unbreakable.”

Code protection is constantly evolving. We at Microchip are committed to continuously improving the code protection features of our products. Attempts to break Microchip's code protection feature may be a violation of the Digital Millennium Copyright Act. If such acts allow unauthorized access to your software or other copyrighted work, you may have a right to sue for relief under that Act.

---

Information contained in this publication regarding device applications and the like is provided only for your convenience and may be superseded by updates. It is your responsibility to ensure that your application meets with your specifications. MICROCHIP MAKES NO REPRESENTATIONS OR WARRANTIES OF ANY KIND WHETHER EXPRESS OR IMPLIED, WRITTEN OR ORAL, STATUTORY OR OTHERWISE, RELATED TO THE INFORMATION, INCLUDING BUT NOT LIMITED TO ITS CONDITION, QUALITY, PERFORMANCE, MERCHANTABILITY OR FITNESS FOR PURPOSE. Microchip disclaims all liability arising from this information and its use. Use of Microchip devices in life support and/or safety applications is entirely at the buyer's risk, and the buyer agrees to defend, indemnify and hold harmless Microchip from any and all damages, claims, suits, or expenses resulting from such use. No licenses are conveyed, implicitly or otherwise, under any Microchip intellectual property rights.

#### **Trademarks**

The Microchip name and logo, the Microchip logo, dsPIC, FlashFlex, KEELOQ, KEELOQ logo, MPLAB, PIC, PICmicro, PICSTART, PIC<sup>32</sup> logo, rPIC, SST, SST Logo, SuperFlash and UNI/O are registered trademarks of Microchip Technology Incorporated in the U.S.A. and other countries.

FilterLab, Hampshire, HI-TECH C, Linear Active Thermistor, MTP, SEEVAL and The Embedded Control Solutions Company are registered trademarks of Microchip Technology Incorporated in the U.S.A.

Silicon Storage Technology is a registered trademark of Microchip Technology Inc. in other countries.

Analog-for-the-Digital Age, Application Maestro, BodyCom, chipKIT, chipKIT logo, CodeGuard, dsPICDEM, dsPICDEM.net, dsPICworks, dsSPEAK, ECAN, ECONOMONITOR, FanSense, HI-TIDE, In-Circuit Serial Programming, ICSP, Mindi, MiWi, MPASM, MPF, MPLAB Certified logo, MPLIB, MPLINK, mTouch, Omniclient Code Generation, PICC, PICC-18, PICDEM, PICDEM.net, PICkit, PICTail, REAL ICE, rFLAB, Select Mode, SQI, Serial Quad I/O, Total Endurance, TSHARC, UniWinDriver, WiperLock, ZENA and Z-Scale are trademarks of Microchip Technology Incorporated in the U.S.A. and other countries.

SQTP is a service mark of Microchip Technology Incorporated in the U.S.A.

GestIC and ULPP are registered trademarks of Microchip Technology Germany II GmbH & Co. KG, a subsidiary of Microchip Technology Inc., in other countries.

All other trademarks mentioned herein are property of their respective companies.

© 2014, Microchip Technology Incorporated, Printed in the U.S.A., All Rights Reserved.

 Printed on recycled paper.

ISBN:978-1-63276-299-3

**QUALITY MANAGEMENT SYSTEM**  
**CERTIFIED BY DNV**  
**== ISO/TS 16949 ==**

*Microchip received ISO/TS-16949:2009 certification for its worldwide headquarters, design and wafer fabrication facilities in Chandler and Tempe, Arizona; Gresham, Oregon and design centers in California and India. The Company's quality system processes and procedures are for its PIC<sup>®</sup> MCUs and dsPIC<sup>®</sup> DSCs, KEELOQ<sup>®</sup> code hopping devices, Serial EEPROMs, microperipherals, nonvolatile memory and analog products. In addition, Microchip's quality system for the design and manufacture of development systems is ISO 9001:2000 certified.*



# MICROCHIP

## Worldwide Sales and Service

### AMERICAS

**Corporate Office**  
2355 West Chandler Blvd.  
Chandler, AZ 85224-6199  
Tel: 480-792-7200  
Fax: 480-792-7277  
Technical Support:  
<http://www.microchip.com/support>  
Web Address:  
[www.microchip.com](http://www.microchip.com)

**Atlanta**  
Duluth, GA  
Tel: 678-957-9614  
Fax: 678-957-1455

**Austin, TX**  
Tel: 512-257-3370

**Boston**  
Westborough, MA  
Tel: 774-760-0087  
Fax: 774-760-0088

**Chicago**  
Itasca, IL  
Tel: 630-285-0071  
Fax: 630-285-0075

**Cleveland**  
Independence, OH  
Tel: 216-447-0464  
Fax: 216-447-0643

**Dallas**  
Addison, TX  
Tel: 972-818-7423  
Fax: 972-818-2924

**Detroit**  
Novi, MI  
Tel: 248-848-4000

**Houston, TX**  
Tel: 281-894-5983

**Indianapolis**  
Noblesville, IN  
Tel: 317-773-8323  
Fax: 317-773-5453

**Los Angeles**  
Mission Viejo, CA  
Tel: 949-462-9523  
Fax: 949-462-9608

**New York, NY**  
Tel: 631-435-6000

**San Jose, CA**  
Tel: 408-735-9110

**Canada - Toronto**  
Tel: 905-673-0699  
Fax: 905-673-6509

### ASIA/PACIFIC

**Asia Pacific Office**  
Suites 3707-14, 37th Floor  
Tower 6, The Gateway  
Harbour City, Kowloon  
Hong Kong  
Tel: 852-2943-5100  
Fax: 852-2401-3431

**Australia - Sydney**  
Tel: 61-2-9868-6733  
Fax: 61-2-9868-6755

**China - Beijing**  
Tel: 86-10-8569-7000  
Fax: 86-10-8528-2104

**China - Chengdu**  
Tel: 86-28-8665-5511  
Fax: 86-28-8665-7889

**China - Chongqing**  
Tel: 86-23-8980-9588  
Fax: 86-23-8980-9500

**China - Hangzhou**  
Tel: 86-571-8792-8115  
Fax: 86-571-8792-8116

**China - Hong Kong SAR**  
Tel: 852-2943-5100  
Fax: 852-2401-3431

**China - Nanjing**  
Tel: 86-25-8473-2460  
Fax: 86-25-8473-2470

**China - Qingdao**  
Tel: 86-532-8502-7355  
Fax: 86-532-8502-7205

**China - Shanghai**  
Tel: 86-21-5407-5533  
Fax: 86-21-5407-5066

**China - Shenyang**  
Tel: 86-24-2334-2829  
Fax: 86-24-2334-2393

**China - Shenzhen**  
Tel: 86-755-8864-2200  
Fax: 86-755-8203-1760

**China - Wuhan**  
Tel: 86-27-5980-5300  
Fax: 86-27-5980-5118

**China - Xian**  
Tel: 86-29-8833-7252  
Fax: 86-29-8833-7256

**China - Xiamen**  
Tel: 86-592-2388138  
Fax: 86-592-2388130

**China - Zhuhai**  
Tel: 86-756-3210040  
Fax: 86-756-3210049

### ASIA/PACIFIC

**India - Bangalore**  
Tel: 91-80-3090-4444  
Fax: 91-80-3090-4123

**India - New Delhi**  
Tel: 91-11-4160-8631  
Fax: 91-11-4160-8632

**India - Pune**  
Tel: 91-20-3019-1500

**Japan - Osaka**  
Tel: 81-6-6152-7160  
Fax: 81-6-6152-9310

**Japan - Tokyo**  
Tel: 81-3-6880-3770  
Fax: 81-3-6880-3771

**Korea - Daegu**  
Tel: 82-53-744-4301  
Fax: 82-53-744-4302

**Korea - Seoul**  
Tel: 82-2-554-7200  
Fax: 82-2-558-5932 or  
82-2-558-5934

**Malaysia - Kuala Lumpur**  
Tel: 60-3-6201-9857  
Fax: 60-3-6201-9859

**Malaysia - Penang**  
Tel: 60-4-227-8870  
Fax: 60-4-227-4068

**Philippines - Manila**  
Tel: 63-2-634-9065  
Fax: 63-2-634-9069

**Singapore**  
Tel: 65-6334-8870  
Fax: 65-6334-8850

**Taiwan - Hsin Chu**  
Tel: 886-3-5778-366  
Fax: 886-3-5770-955

**Taiwan - Kaohsiung**  
Tel: 886-7-213-7830

**Taiwan - Taipei**  
Tel: 886-2-2508-8600  
Fax: 886-2-2508-0102

**Thailand - Bangkok**  
Tel: 66-2-694-1351  
Fax: 66-2-694-1350

### EUROPE

**Austria - Wels**  
Tel: 43-7242-2244-39  
Fax: 43-7242-2244-393

**Denmark - Copenhagen**  
Tel: 45-4450-2828  
Fax: 45-4485-2829

**France - Paris**  
Tel: 33-1-69-53-63-20  
Fax: 33-1-69-30-90-79

**Germany - Dusseldorf**  
Tel: 49-2129-3766400

**Germany - Munich**  
Tel: 49-89-627-144-0  
Fax: 49-89-627-144-44

**Germany - Pforzheim**  
Tel: 49-7231-424750

**Italy - Milan**  
Tel: 39-0331-742611  
Fax: 39-0331-466781

**Italy - Venice**  
Tel: 39-049-7625286

**Netherlands - Drunen**  
Tel: 31-416-690399  
Fax: 31-416-690340

**Poland - Warsaw**  
Tel: 48-22-3325737

**Spain - Madrid**  
Tel: 34-91-708-08-90  
Fax: 34-91-708-08-91

**Sweden - Stockholm**  
Tel: 46-8-5090-4654

**UK - Wokingham**  
Tel: 44-118-921-5800  
Fax: 44-118-921-5820

03/25/14

## Данный компонент на территории Российской Федерации

### Вы можете приобрести в компании MosChip.

Для оперативного оформления запроса Вам необходимо перейти по данной ссылке:

<http://moschip.ru/get-element>

Вы можете разместить у нас заказ для любого Вашего проекта, будь то серийное производство или разработка единичного прибора.

В нашем ассортименте представлены ведущие мировые производители активных и пассивных электронных компонентов.

Нашей специализацией является поставка электронной компонентной базы двойного назначения, продукции таких производителей как XILINX, Intel (ex.ALTERA), Vicor, Microchip, Texas Instruments, Analog Devices, Mini-Circuits, Amphenol, Glenair.

Сотрудничество с глобальными дистрибьюторами электронных компонентов, предоставляет возможность заказывать и получать с международных складов практически любой перечень компонентов в оптимальные для Вас сроки.

На всех этапах разработки и производства наши партнеры могут получить квалифицированную поддержку опытных инженеров.

Система менеджмента качества компании отвечает требованиям в соответствии с ГОСТ Р ИСО 9001, ГОСТ РВ 0015-002 и ЭС РД 009

### Офис по работе с юридическими лицами:

105318, г.Москва, ул.Щербаковская д.3, офис 1107, 1118, ДЦ «Щербаковский»

Телефон: +7 495 668-12-70 (многоканальный)

Факс: +7 495 668-12-70 (доб.304)

E-mail: [info@moschip.ru](mailto:info@moschip.ru)

Skype отдела продаж:

moschip.ru

moschip.ru\_4

moschip.ru\_6

moschip.ru\_9