

LOW VOLTAGE OPERATION DUAL H BRIDGE DRIVER

■ GENERAL DESCRIPTION

The NJU7382A is a dual H-bridge driver IC that features low voltage operation and low quiescent current.

The control method is Phase & Enable inputs type.

The independent comparator circuit can be used for position sensing signal processing and the others.

Small package makes the NJU7382A suitable for small stepper motor, such as portable applications.

■ PACKAGE OUTLINE

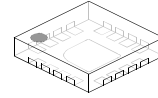

NJU7382AMJE
(EQFN16-JE)

■ FEATURES

- Supply Voltage : $V_{DD}=1.8V$ to $5.5V$
- Output Current : $I_O=200mA$ (Continuous)
 $I_O=400mA$ (Peak)
- Output ON Resistance : $R_{O(H+L)}=1.25\Omega$ typ. at $V_{DD}=3.3V$
 $R_{O(H+L)}=1.95\Omega$ typ. at $V_{DD}=1.8V$
- Low Quiescent Current : $60\mu A$ typ. at $V_{DD}=3.3V$
- Phase & Enable Inputs Control
- Built-in Comparator Circuit
- Protection Circuit : Thermal Shutdown Circuit (TSD)
- Package Outline : EQFN16-JE

■ BLOCK DIAGRAM

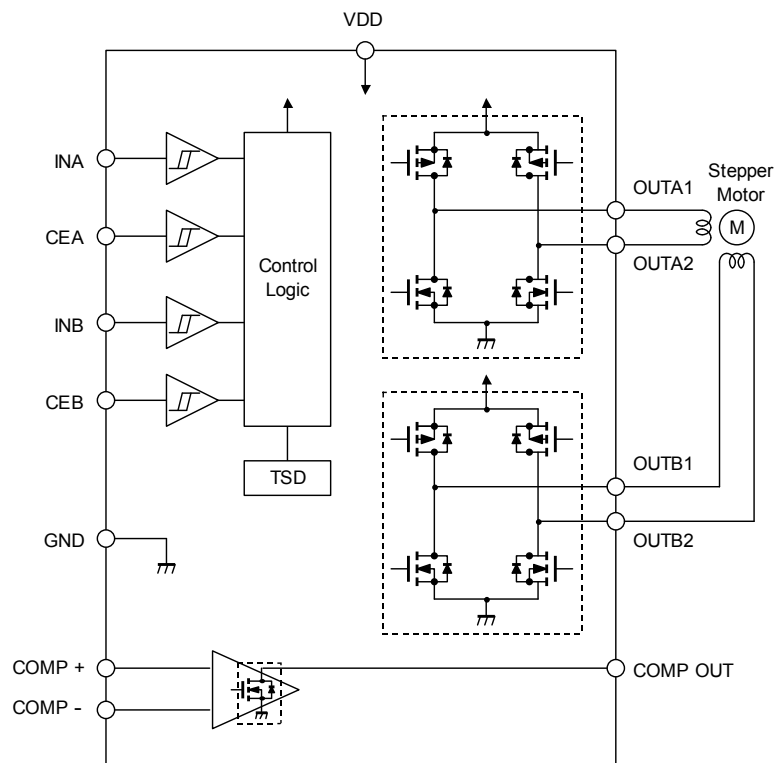

NJU7382A

■ PIN CONFIGURATION

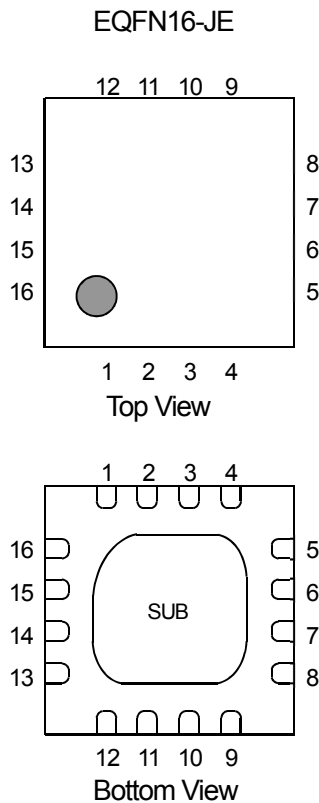

■ PIN DESCRIPTION

PIN No. EQFN16	PIN NAME	FUNCTION	NOTES
1	INB	Bch Phase Input Pin 1	-
2	CEB	Bch Enable Input Pin 2	-
3,11	VDD	Power Supply Pin	Both pins must be connected together externally.
4	CEA	Ach Enable Input Pin 2	-
5	INA	Ach Phase Input Pin 1	-
6	OUTA2	Ach Output Pin 2	-
7,15	GND	Ground Pin	Both pins must be connected together externally.
8	OUTA1	Ach Output Pin 1	-
9	COMP OUT	Comparator Output Pin	When not using, it should be set to open.
10	NC	No Connection	Not Internally Connected
12	COMP+	Comparator Non-inverted Input Pin	When not using, it should be connected to VDD.
13	COMP-	Comparator Inverted Input Pin	When not using, it should be connected to GND.
14	OUTB1	Bch Output Pin 1	-
16	OUTB2	Bch Output Pin 2	-
SUB	SUB	Back Side Thermal PAD (SUB)	The PAD is connected with the internal VDD. It must be set to open or connected to VDD.

■ ABSOLUTE MAXIMUM RATINGS

(Ta=25°C)

PARAMETER	SYMBOL	RATINGS	UNIT	NOTES
Supply Voltage	V _{DD}	7	V	-
Logic Input Voltage	V _{ID}	-0.3 to V _{DD} +0.3	V	-
Motor Output Current (Peak)	I _{OPEAK}	400	mA	Per channel
Comparator Output Current	I _{CO}	10	mA	-
Comparator Output Voltage	V _{CO}	7	V	-
Operating Ambient Temperature	T _{opr}	-40 to +85	°C	-
Junction Temperature	T _j	-40 to +150	°C	-
Storage Temperature	T _{stg}	-50 to +150	°C	-
Power Dissipation (EQFN16-JE)	P _D	720	mW	2 Layers on PCB (*1)
		1800		4 Layers on PCB (*2)

*1: Mounted on glass epoxy board based on EIA/JEDEC. (101.5×114.5×1.6mm, FR-4, 2Layers, connected exposed PAD)

*2: Mounted on glass epoxy board on EIA/JEDEC. (101.5×114.5×1.6mm, FR-4, 4Layers, Inner Cu area : 99.5×99.5mm,
In addition thermal via holes, connected exposed PAD)

■ RECOMMENDED OPERATING CONDITIONS

(V_{DD}=3.3V, Ta=25°C)

PARAMETER	SYMBOL	TEST CONDITIONS	MIN.	TYP.	MAX.	UNIT
Supply Voltage 1	V _{DD1}	Not using comparator block (*3)	1.8	-	5.5	V
Supply Voltage 2	V _{DD1}	Using comparator block (*3)	2.0	-	5.5	V
Motor Output Current (Continuous)	I _O	Per channel	-	-	200	mA

*3: Output voltage may not be provided enough depending on output current level, please review output ON resistance spec.

NJU7382A

■ ELECTRICAL CHARACTERISTICS

($V_{DD}=3.3V$, $T_a=25^{\circ}C$)

PARAMETER	SYMBOL	TEST CONDITIONS	MIN.	TYP.	MAX.	UNIT
■ GENERAL						
Quiescent Current 1	I_{DD1}		-	60	120	μA
Quiescent Current 2	I_{DD2}	$V_{DD}=1.8V$	-	50	100	μA
Thermal Shutdown Temperature	T_{TSD}		-	190	-	$^{\circ}C$
Thermal Shutdown Hysteresis	T_{HYS}		-	40	-	$^{\circ}C$
■ LOGIC BLOCK						
H Level Input Voltage 1	V_{IH1}		2.4	-	V_{DD}	V
H Level Input Voltage 2	V_{IH2}	$V_{DD}=1.8V$	1.4	-	V_{DD}	V
L Level Input Voltage 1	V_{IL1}		0	-	0.8	V
L Level Input Voltage 2	V_{IL2}	$V_{DD}=1.8V$	0	-	0.4	V
Input Hysteresis Width	V_{IHYS}		-	0.2	-	V
Input Current	I_i	Per 1 Input	-200	-	200	nA
Input Pulse Width	t_p		2	-	-	μs
■ DRIVER BLOCK						
High Side Output ON Resistance 1	R_{ONH1}	$I_o=200mA$	-	0.75	1.0	Ω
High Side Output ON Resistance 2	R_{ONH2}	$V_{DD}=2.1V, I_o=200mA$	-	1.0	1.35	Ω
High Side Output ON Resistance 3	R_{ONH3}	$V_{DD}=1.8V, I_o=200mA$	-	1.2	1.6	Ω
Low Side Output ON Resistance 1	R_{ONL1}	$I_o=200mA$	-	0.5	0.7	Ω
Low Side Output ON Resistance 2	R_{ONL2}	$V_{DD}=2.1V, I_o=200mA$	-	0.65	0.9	Ω
Low Side Output ON Resistance 3	R_{ONL3}	$V_{DD}=1.8V, I_o=200mA$	-	0.75	1.05	Ω
R_{ONH} Temperature Coefficient	$\Delta R_{ONH}/\Delta T_j$	$T_j=40\sim 125^{\circ}C, I_o=200mA$	-	4.0	-	$m\Omega/^{\circ}C$
R_{ONL} Temperature Coefficient	$\Delta R_{ONL}/\Delta T_j$	$T_j=40\sim 125^{\circ}C, I_o=200mA$	-	3.0	-	$m\Omega/^{\circ}C$
High Side Reverse Voltage	V_{ORH}	$I_o=-200mA$	-	0.85	1.0	V
Low Side Reverse Voltage	V_{ORL}	$I_o=-200mA$	-	0.75	0.9	V
High Side Leak Current	I_{OLEAKH}	$V_{DD}=7.0V$	-	-	1	μA
Low Side Leak Current	I_{OLEAKL}	$V_{DD}=7.0V$	-	-	1	μA
Output Turn On Time	t_{ON}		-	400	-	ns
Output Turn Off Time	t_{OFF}		-	30	-	ns
Dead Time	t_d		-	370	-	ns
■ COMPARATOR BLOCK						
Input Offset Voltage	V_{IO}		-12	-	+12	mV
Input Bias Current	I_{IB}		-	1	-	pA
Common Mode Input Voltage Range	V_{ICM}		0	-	$V_{DD}-0.5$	V
Output Voltage	V_{sat}	$R_L=10k\Omega$	-	0.1	-	V
Output Leak Current	I_{COLEAK}	$V_{CO}=5.5V$	-	-	1	μA

■ THERMAL RESISTANCE

PARAMETER	SYMBOL	TEST CONDITIONS	MIN.	TYP.	MAX.	UNIT
Junction - Ambient Thermal Resistance 1	θ_{ja_1}	Mounted on glass epoxy board based on EIA/JEDEC. (101.5×114.5×1.6mm, FR-4, 2Layers, connected exposed PAD)	-	-	173	°C/W
Junction - Case Surface Thermal Resistance 1	ψ_{jc_1}		-	21	-	°C/W
Junction - Ambient Thermal Resistance 2	θ_{ja_2}	Mounted on glass epoxy board based on EIA/JEDEC. (101.5×114.5×1.6mm, FR-4, 4Layers, Inner Cu area : 99.5×99.5mm, In addition thermal via holes, connected exposed PAD)	-	-	69	°C/W
Junction - Case Surface Thermal Resistance 2	ψ_{jc_2}		-	11	-	°C/W

■ POWER DISSIPATION vs. AMBIENT TEMPERATURE

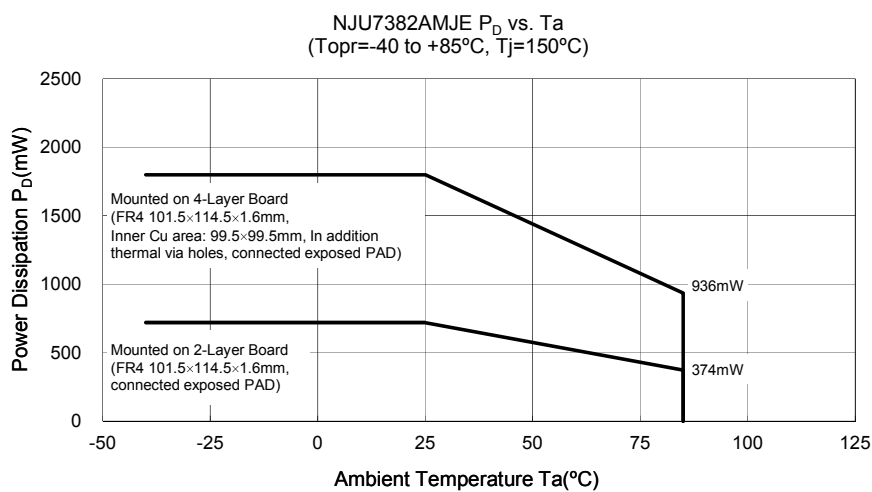

NJU7382A

INPUT - OUTPUT TRUTH TABLE

INPUT				OUTPUT				Comparator Circuit	NOTES	
INA	CEA	INB	CEB	OUTA1	OUTA2	OUTB1	OUTB2			
L	L	-	-	OFF	OFF	-	-	Normal Operation	Ach	OFF(Fast Decay)
H				L	L					H
L	H			L	H					CW
H	H			L	L					OFF(Fast Decay)
-	-	L	L	-	-	OFF	OFF		Bch	OFF(Fast Decay)
		H	L			L	H			CCW
		L	H			H	L			CW
Don't Care				OFF	OFF	OFF	OFF			TSD

*OFF=Hi-Z

COMPARATOR TRUTH TABLE (Normal Operation)

INPUT		OUTPUT	NOTES
COMP+	COMP-	COMPOUT	
H	L	OFF	FET: OFF Operation
L	H	L	FET: ON Operation

*OFF=Hi-Z

BASIC OPERATION TIMING CHART

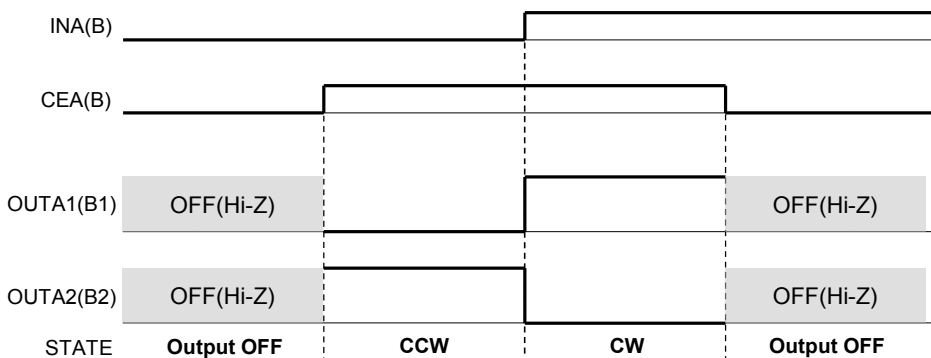

BASIC OUTPUT OPERATION PATTERN

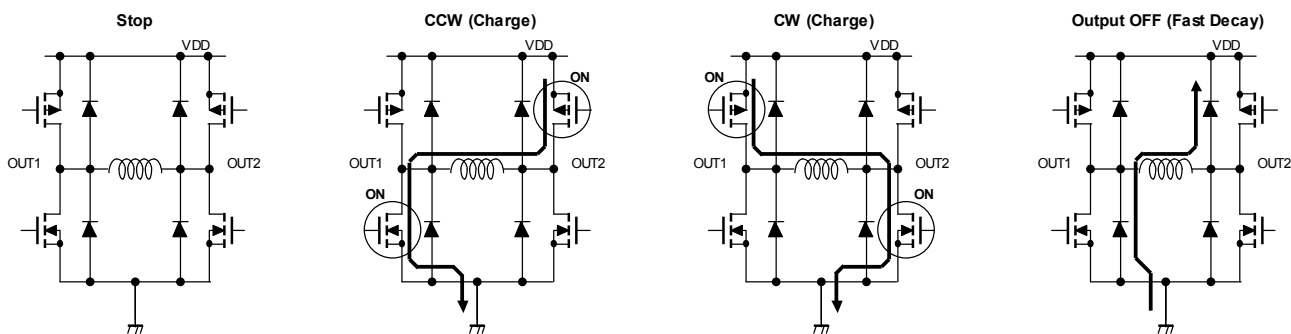

■ TYPICAL APPLICATION

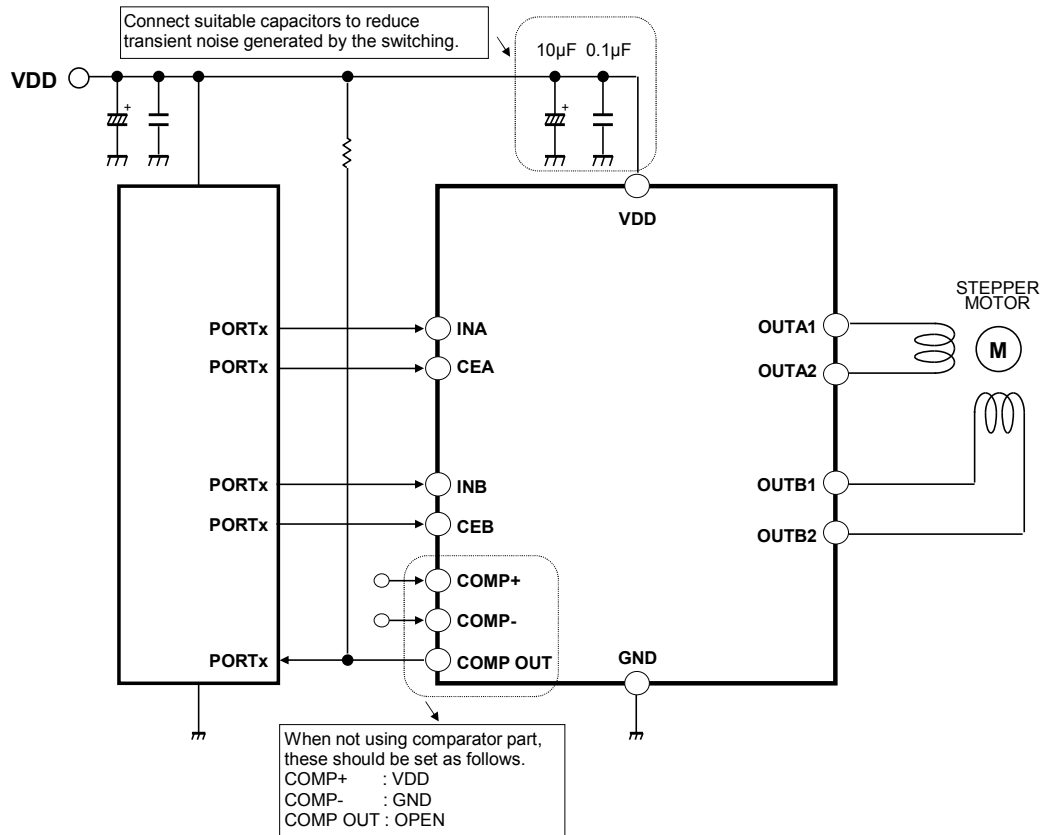

NJU7382A

■ STEPPER MOTOR DRIVE APPLICATION

• TIMING CHART

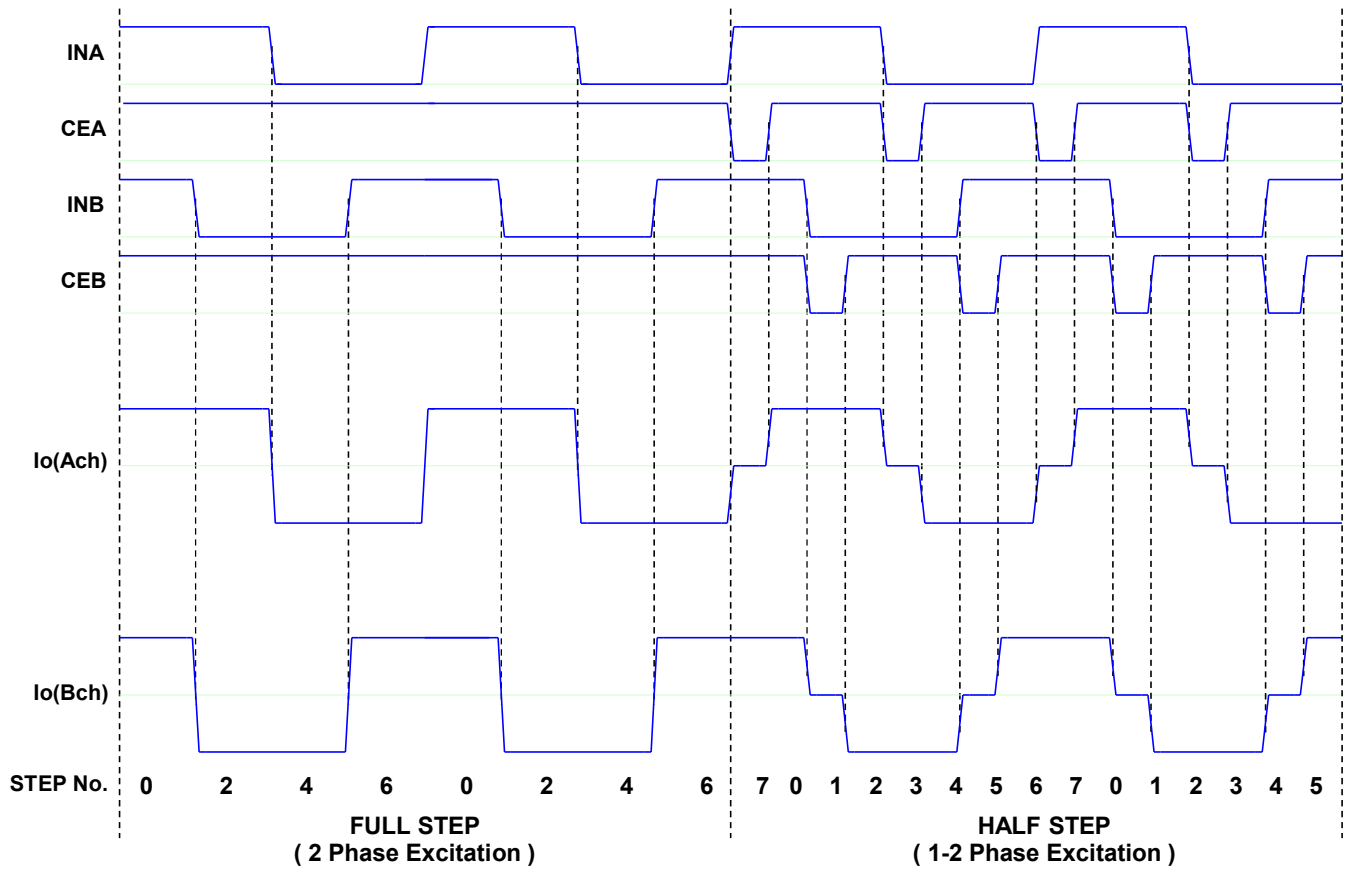

• ROTER POSITION (STEP No.)

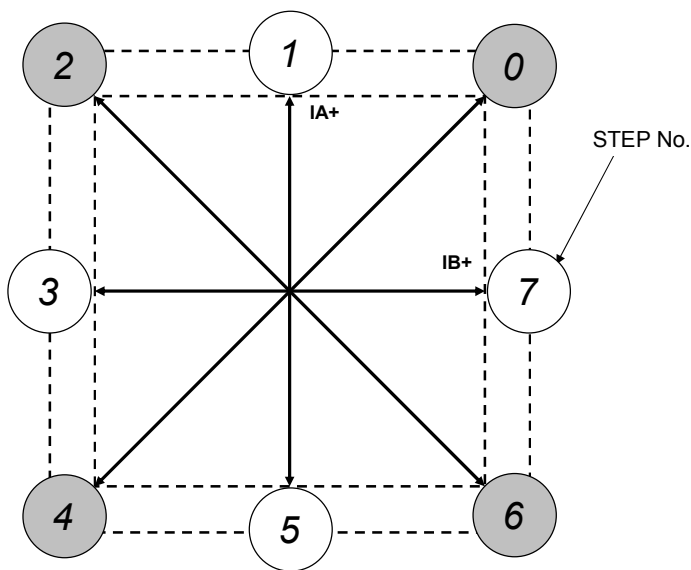

■ TYPICAL CHARACTERISTICS

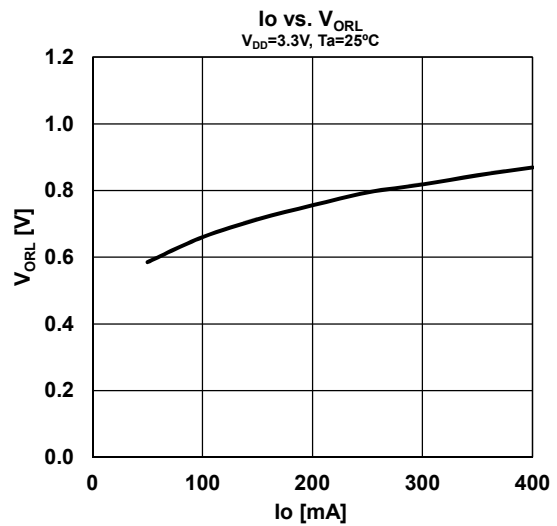
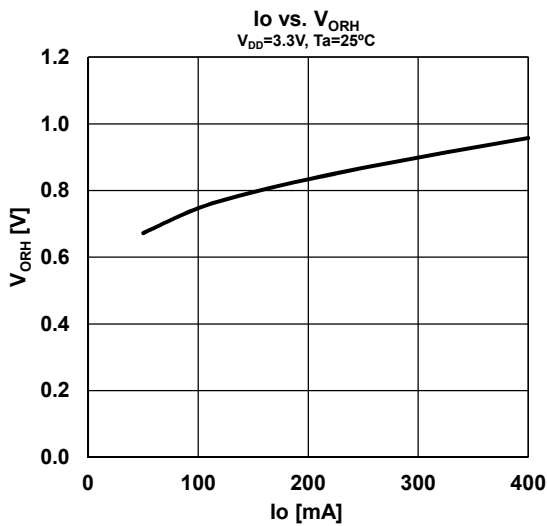
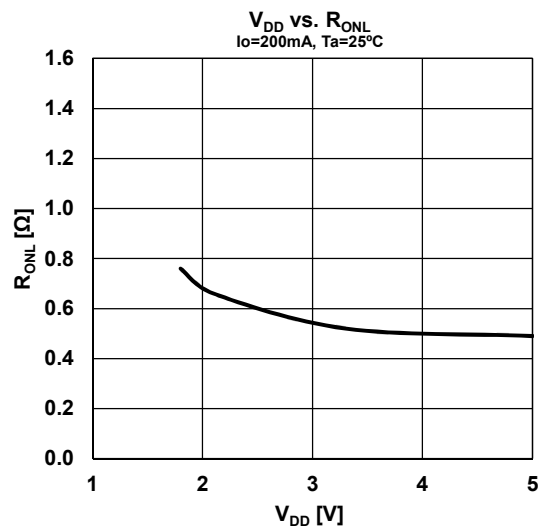
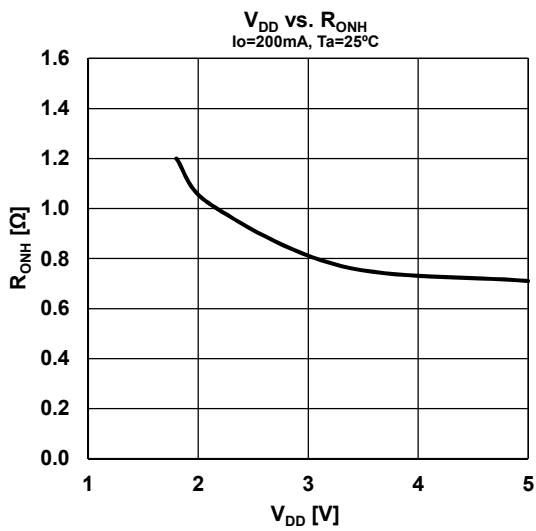
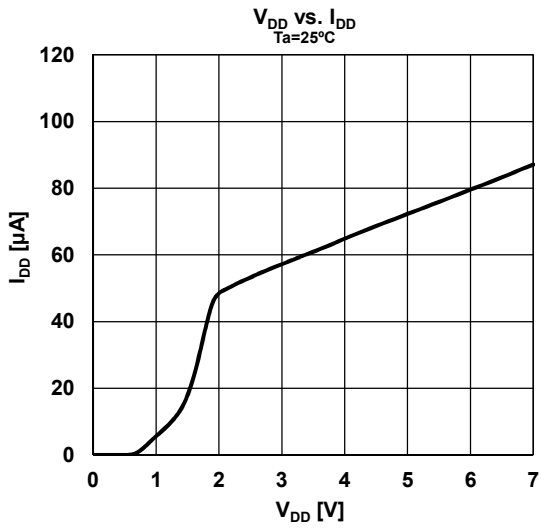

■ TYPICAL CHARACTERISTICS

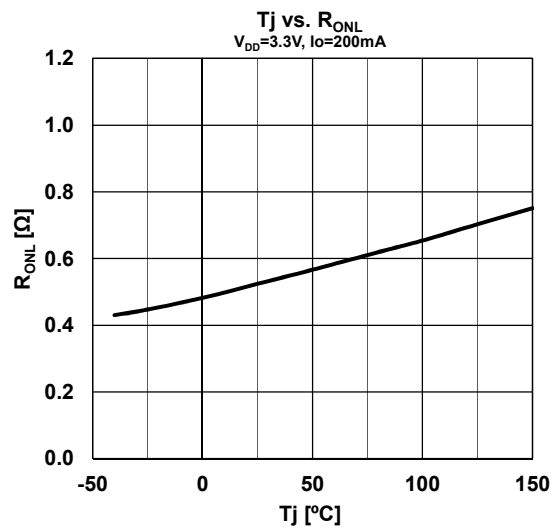
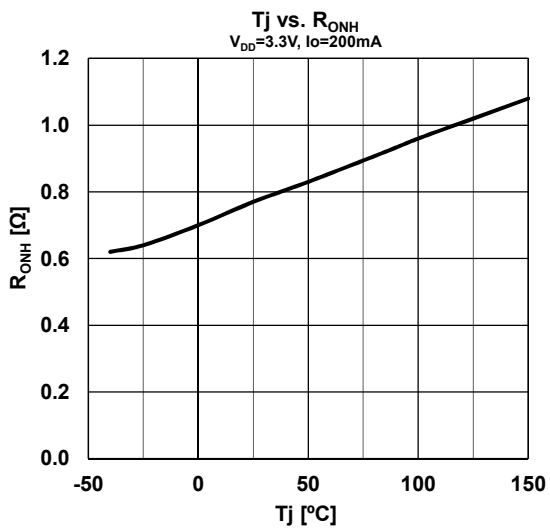
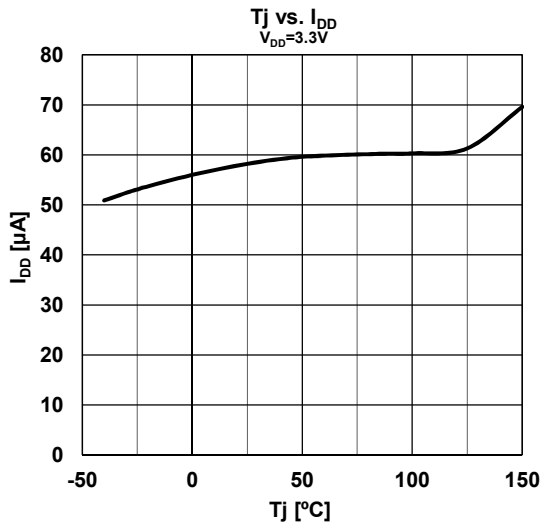

[CAUTION]

The specifications on this databook are only given for information, without any guarantee as regards either mistakes or omissions. The application circuits in this databook are described only to show representative usages of the product and not intended for the guarantee or permission of any right including the industrial rights.

Mouser Electronics

Authorized Distributor

Click to View Pricing, Inventory, Delivery & Lifecycle Information:

[NJR:](#)

[NJU7382AMJE-TE3](#)

Данный компонент на территории Российской Федерации

Вы можете приобрести в компании MosChip.

Для оперативного оформления запроса Вам необходимо перейти по данной ссылке:

<http://moschip.ru/get-element>

Вы можете разместить у нас заказ для любого Вашего проекта, будь то серийное производство или разработка единичного прибора.

В нашем ассортименте представлены ведущие мировые производители активных и пассивных электронных компонентов.

Нашей специализацией является поставка электронной компонентной базы двойного назначения, продукции таких производителей как XILINX, Intel (ex.ALTERA), Vicor, Microchip, Texas Instruments, Analog Devices, Mini-Circuits, Amphenol, Glenair.

Сотрудничество с глобальными дистрибьюторами электронных компонентов, предоставляет возможность заказывать и получать с международных складов практически любой перечень компонентов в оптимальные для Вас сроки.

На всех этапах разработки и производства наши партнеры могут получить квалифицированную поддержку опытных инженеров.

Система менеджмента качества компании отвечает требованиям в соответствии с ГОСТ Р ИСО 9001, ГОСТ РВ 0015-002 и ЭС РД 009

Офис по работе с юридическими лицами:

105318, г.Москва, ул.Щербаковская д.3, офис 1107, 1118, ДЦ «Щербаковский»

Телефон: +7 495 668-12-70 (многоканальный)

Факс: +7 495 668-12-70 (доб.304)

E-mail: info@moschip.ru

Skype отдела продаж:

moschip.ru

moschip.ru_4

moschip.ru_6

moschip.ru_9