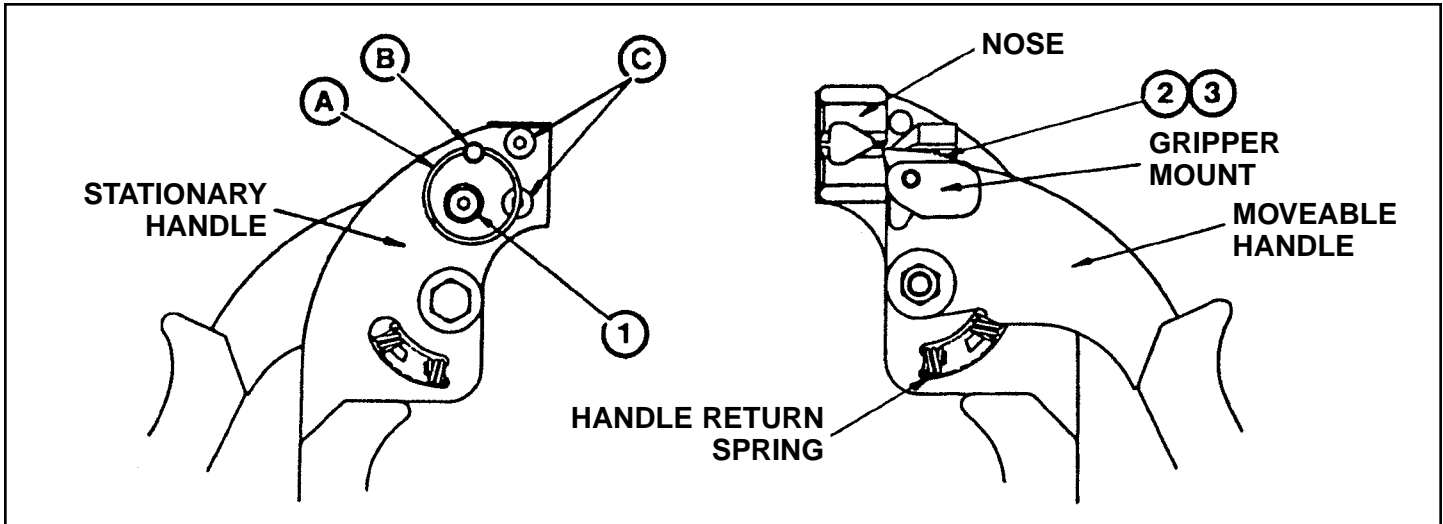

**BT2MS75 AND ST2MT GRIPPER REPLACEMENT KIT  
INSTALLATION INSTRUCTIONS**

© Panduit Corp. 2004

The KT2MG Gripper Replacement Kit replaces the current gripper in the event of reduced performance or excessive wear caused by extended usage. Follow the step-by-step instructions below:

**CONTENTS:**

<u>ITEM</u>	<u>QUANTITY</u>	<u>DESCRIPTION</u>
1	1	GRIPPER PIN
2	1	GRIPPER
3	1	GRIPPER COMPRESSION SPRING
4	1	1/8" HEX WRENCH (NOT SHOWN)

**REMOVAL AND INSTALLATION OF THE GRIPPER****WARNING: SAFETY GLASSES MUST BE WORN DURING THE INSTALLATION OF THIS KIT.**

1. Remove the support ring (A) and the support ring pin (B) from the stationary handle.
2. Remove the gripper pin (1) through the hole in the stationary handle, using the included 1/8" hex wrench. Remove the gripper (2) and the gripper compression spring (3) from the gripper mount. Discard the old gripper pin, gripper and gripper compression spring.
3. While performing this step, hold the tool handles together in one hand. With the other hand, remove the tool nose by removing the two nose screws (C), using the 1/8" hex wrench from the back of the stationary handle. Do not release handles until reading further.

**CAUTION: Opening handles too quickly may cause handle return spring to be ejected from the tool.** Carefully hold on to the existing handle return spring while slowly opening the handles to remove the spring from tool.

For Regional Technical Support:  
[www.panduit.com/location/index.asp](http://www.panduit.com/location/index.asp)

[www.panduit.com](http://www.panduit.com)

E-mail: [cs@panduit.com](mailto:cs@panduit.com)  
Fax: 630-759-7532

---

## KT2MG INSTALLATION INSTRUCTIONS

---

4. Apply a small amount of general-purpose lubricant to the new gripper pin (1). Apply a small amount of grease to both ends of the new gripper compression spring (3) and insert one end of spring into the recess in the back of the new gripper (2). Carefully insert the gripper and spring into the gripper mount so that the spring is inserted into the recess in the gripper mount. Press the gripper into the gripper mount until the gripper hole lines up with the gripper mount holes. While holding the gripper in alignment, insert the gripper pin through the hole in the stationary handle, moveable handle, gripper mount and gripper; and thread into the gripper mount 2-3 turns only. Do not tighten.
5. Position the handle return spring between the spring tab on the stationary handle and the spring tab on the moveable handle. While holding spring in position, slowly close and hold tool handles closed with one hand. With the other hand, fasten the tool nose to the tool using the two existing nose screws (C), and tighten using the 1/8" hex wrench.
6. Release handles and check for free movement of gripper. Verify that the gripper is in the open position when the handles are opened. While the handles are opened, tighten the gripper pin at the location on the back of the stationary handle using the 1/8" hex wrench. Verify that the gripper still moves freely. If the gripper does not move freely, check the assembly and reassemble.
7. Insert the support ring pin (B) into the stationary handle and re-install the support ring (A).

# Mouser Electronics

Authorized Distributor

Click to View Pricing, Inventory, Delivery & Lifecycle Information:

[Panduit:](#)

[KT2MG](#)

## Данный компонент на территории Российской Федерации

### Вы можете приобрести в компании MosChip.

Для оперативного оформления запроса Вам необходимо перейти по данной ссылке:

<http://moschip.ru/get-element>

Вы можете разместить у нас заказ для любого Вашего проекта, будь то серийное производство или разработка единичного прибора.

В нашем ассортименте представлены ведущие мировые производители активных и пассивных электронных компонентов.

Нашей специализацией является поставка электронной компонентной базы двойного назначения, продукции таких производителей как XILINX, Intel (ex.ALTERA), Vicor, Microchip, Texas Instruments, Analog Devices, Mini-Circuits, Amphenol, Glenair.

Сотрудничество с глобальными дистрибьюторами электронных компонентов, предоставляет возможность заказывать и получать с международных складов практически любой перечень компонентов в оптимальные для Вас сроки.

На всех этапах разработки и производства наши партнеры могут получить квалифицированную поддержку опытных инженеров.

Система менеджмента качества компании отвечает требованиям в соответствии с ГОСТ Р ИСО 9001, ГОСТ РВ 0015-002 и ЭС РД 009

### Офис по работе с юридическими лицами:

105318, г.Москва, ул.Щербаковская д.3, офис 1107, 1118, ДЦ «Щербаковский»

Телефон: +7 495 668-12-70 (многоканальный)

Факс: +7 495 668-12-70 (доб.304)

E-mail: [info@moschip.ru](mailto:info@moschip.ru)

Skype отдела продаж:

moschip.ru

moschip.ru\_4

moschip.ru\_6

moschip.ru\_9