

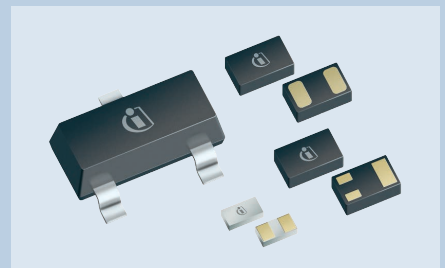

RF & Protection Devices

Selection Guide

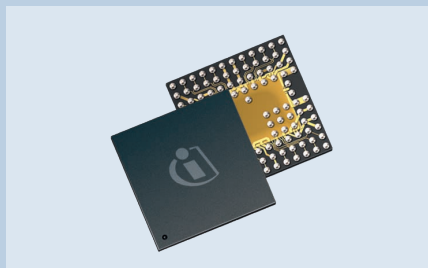
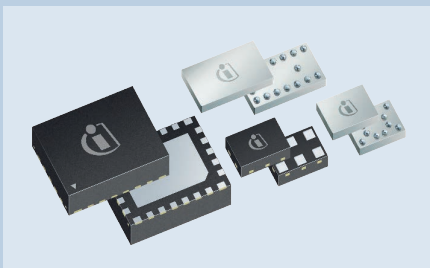

Content

RF MMIC LNAs	4	RF Pin Diode	10
LTE LNAs	4	Band Switching and RF Attenuation	10
GNSS LNAs	5	Antenna Switch	11
General Purpose LNAs	5		
		RF Varactor Diode	13
RF Modules	5	VCO and Low Voltage Tuner	13
Navigation Rx Front-End	5	FM Tuner	13
		SAT Tuner	13
		UHF and VHF Tuner	13
RF Switches	6		
Antenna Switch Module	6	RF Mixer + Detector Schottky Diode	14
Diversity Switches	6		
General Purpose Switches	6	RF mmW-MMIC	15
		24GHz Industrial	15
Antenna Tuning	6	Backhaul	15
Antenna Aperture Tuning RF Switches	6		
		ESD & EMI Protection and Filters	16
RF Transistors	7	Multi-Purpose ESD Devices	16
Low Noise Si Transistors up to 2.5GHz	7	Low Capacitance ESD Devices	18
Low Noise Si Transistors up to 5GHz	7	Surge Protection Devices	18
Ultra Low Noise SiGe:C Transistors for use up to 12GHz	7		
High Linearity Si- and SiGe:C-Transistors for use up to 6GHz	8	Alphanumerical List of the Symbols used	20
Biased Low Noise RF Transistor	8		
		Package Information	22
RF MOSFET	9		
Single Full Biased	9		
Single Non Biased	9		
Single Semi Biased	9		
Dual Semi Biased	9		



RF MMIC LNAs

LTE LNAs

Product Type	f [MHz]	Gain (typ) [dB]	F (typ)	P _{1dB} (in) [dBm]	I (typ) [mA]	Package	
BGA622L7	2100	16.00	1.10	-16	5.8	TSLP-7-1	
BGA711N7	2100	17.00	1.10	-8	3.6	TSNP-7-1	
BGA713N7	700	15.50	1.10	-7	4.8	TSNP-7-1	
BGA728L7	170–1675	15.75	1.30	-10	0.5	5.8	TSLP-7-1
BGA734L16	800 1900 2100	15.20 16.50	1.20 1.00 1.10	-12 -10 -11	3.5 3.4	–	TSLP-16-1
BGA735N16	900/1900/2100	16.00	1.10	-5	3.4	–	TSNP-16-1
BGA748L16	2140 1960 940 880	17.40 16.50 16.20	1.10 1.20	-10 -8 -7 -6	4.4 4.0 3.8	–	TSLP-16-1
BGA751N7	800	15.80	1.05	-5	3.3	–	TSNP-7-1
BGA777N7	2300–2700	15.70	1.20	-10	4.2	–	TSNP-7-1
BGA7H1N6	2300–2690	12.50	–	-1	4.7	–	TSNP-6-2
BGA 7L1N6	728–960	13.30	–	-2	4.4	–	TSNP-6-2
BGA7M1N6	1805–2200	13.00	–	0	4.4	–	TSNP-6-2
BGM7MLLM4L12	700–2100	13.00	0.70	0	4.5	–	TSLP-12-4
BGM7LLHM4L12	700–2700	13.00	0.70	0	4.5	–	TSLP-12-4
BGM7LMHM4L12	700–2700	13.00	0.70	0	4.5	–	TSLP-12-4



www.infineon.com/rfmmics

GNSS LNAs

Product Type	Gain (typ) [dB]	F (typ) [dB]	P _{1dB} (in) [dBm]	I (typ) [mA]	f [MHz]	Package
BGA231L7	16.0	0.75	-5.0	4.4	1550-1615	TSLP-7-1
BGA231N7	16.0	0.75	-5.0	4.4	1550-1615	TSNP-7-1
BGA524N6	19.6	0.55	-12.0	2.5	-	TSNP-6-2
BGA715N7	20.0	0.75	-15.5	3.3	1550-1615	TSNP-7-1
BGA725L6	20.0	0.65	-16.0	3.6	1550-1615	TSLP-6-2
BGA824N6	17.0	0.55	-6.0	3.9	-	TSNP-6-2
BGA825L6S	17.0	0.60	-7.0	4.8	1550-1615	TSLP-6-3
BGA915N7	15.5	0.70	-5.0	4.4	1550-1615	TSNP-7-6
BGA924N6	16.2	0.55	-5.0	4.9	-	TSNP-6-2
BGA925L6	15.8	0.65	-5.0	4.9	1550-1615	TSLP-6-2

General Purpose LNAs

Product Type	Gain (typ) [dB]	F (typ) [dB]	P _{1dB} (out) [dBm]	I (typ) [mA]		f [MHz]	Package
BGA728L7	15.75	1.3	-	0.5	5.8	170-1675	TSLP-7-1
BGB707L7ESD	-	0.4	10	2.1	25.0	50-10000	TSLP-7-1
BGB717L7ESD	12.00	1.0	4	3.0	-	50-1000	TSLP-7-1
BGB741L7ESD	19.00	1.0	10	5.5	30.0	30-5000	TSLP-7-1
BGB719N7ESD	13.50	1.2	6	2.8	-	10-1000	TSNP-7-6

Application notes, Data sheets, Simulation data: www.infineon.com/rfmmic.documents

RF Modules

Navigation Rx Front-End

Product Type	I (typ) [mA]	Gain (typ) [dB]	NF _{min} (typ) [dB]	P _{1dB} (in) [dBm]	f [MHz]	V _{cc} (typ) [V]		Package
BGM1143N9	3.9	15.5	1.45	-6	1550-1615	1.5	3.3	TSNP-9-1
BGM1032N7	4.0	14.8	1.65	-6	1570-1615	2.7	-	TSNP-7-10
BGM1033N7	4.0	14.8	1.65	-6	1570-1615	2.7	-	TSNP-7-10
BGM1034N7	3.9	17.0	1.70	-15	1570-1615	1.8	-	TSNP-7-10
BGM1043N7	3.9	17.0	1.50	-6	1570-1615	-	-	TSNP-7-10

Product information: www.infineon.com/rfmodule



RF Switches

Antenna Switch Module

Product Type	Switch Type	Control Interface	f [GHz]	P _{max} [dBm]	Insertion Loss @ 1GHz [dB]	Isolation @ 1GHz [dB]	Supply Voltage [V]	Package
BGSF110GN26	SP10T	GPIO	0.1–3.8	36	0.5	37	2.4–3.3	TSNP-26-2
BGSF1717MN26	DP14T	MIPI RFFE	0.1–2.7	36	0.5	47	2.4–5.5	TSNP-26-3

Diversity Switches

Product Type	Switch Type	Control Interface	f [GHz]	P _{max} [dBm]	Insertion Loss @ 1GHz [dB]	Isolation @ 1GHz [dB]	Supply Voltage [V]	Package
BGS14AN16	SP4T	GPIO	0.1–3.0	30	0.34	40	2.85–4.7	TSNP-16-6
BGS15AN16	SP5T	GPIO	0.1–3.0	32	0.34	35	2.85–4.7	TSNP-16-6
BGS16MN14	SP6T	MIPI RFFE	0.1–2.7	32	0.30	–	2.50–5.5	TSNP-14-3
BGS18MN14	SP8T	MIPI RFFE	0.1–2.7	32	0.35	–	2.50–5.5	TSNP-14-3

General Purpose Switches

Product Type	Switch Type	Control Interface	f [GHz]	P _{max} [dBm]	Insertion Loss @ 1GHz [dB]	Isolation @ 1GHz [dB]	Supply Voltage [V]	Package
BGS12AL7-4	SPDT	GPIO	0.1–3	24.0	0.40	32	2.4–3.6	TSLP-7-4
BGS12AL7-6	SPDT	GPIO	0.1–3	24.0	0.40	32	2.4–3.6	TSLP-7-6
BGS12PL6	SPDT	GPIO	0.1–4	35.0	0.40	37	2.4–3.6	TSLP-6-4
BGS12SL6	SPDT	GPIO	0.1–6	27.5	0.25	36	2.4–3.6	TSLP-6-4
BGS12SN6	SPDT	GPIO	0.1–6	30.0	0.25	40	1.8–3.3	TSNP-6-2
BGS13SL9	SP3T	GPIO	0.1–3	30.0	0.35	37	2.4–3.6	TSLP-9-3
BGS22WL10	DPDT	GPIO	0.1–3	30.0	0.33	38	2.4–3.6	TSLP-10-1
BGS22W2L10	DPDT	GPIO	0.1–3	30.0	0.33	35	2.4–3.6	TSLP-10-1

Application notes, Data sheets, Simulation data: www.infineon.com/rfswitches.documents

Antenna Tuning

Antenna Aperture Tuning RF Switches

Product Type	V _{RF} (max) 1000h [V]	V _{RF} (max) [V]	ESD @ ANT kV	R _{ON} [Ω]	C _{OFF} [fF]	R _{ON} × C _{OFF} [fs]	H2 @ 25dBm [dBc]	H3 @ 25dBm [dBc]	Package
BGSA12GN10	40	36	8	1.6	120	< 200	-105	-115	TSNP-10-1
BGSA13GN10	40	36	8	0.8 = RF1 1.3 = RF2 1.6 = RF2	240 = RF1 145 = RF2 120 = RF3	< 200	-105	-115	TSNP-10-1
BGSA14GN10	40	36	8	1.6	120	< 200	-105	-115	TSNP-10-1

Product information: www.infineon.com/rfswitches



www.infineon.com/rfswitches

RF Transistors

Low Noise Si Transistors up to 2.5GHz

Product Type	V _{CEO} (max) [V]	I _C (max) [mA]	NF _{min} (typ) [dB]	G _{max} (typ) [dB]	OIP3 [dBm]	OP1dB [dBm]	f _T (typ) [GHz]	P _{tot} (max) [mW]	Package
For Low Frequencies e.g. VHF/UHF									
BFP181	12	20	0.9	21.0	16.5	-2.0	8.0	175	SOT143
BFR181	12	20	0.9	18.5	18.0	-1.0	8.0	175	SOT23
BFR181W	12	20	0.9	19.0	18.0	-1.0	8.0	175	SOT323
BFP182R	12	35	0.9	22.0	24.0	5.0	8.0	250	SOT143
BFP182W	12	35	0.9	22.0	24.0	5.0	8.0	250	SOT343
BFR182	12	35	0.9	18.0	24.5	5.0	8.0	250	SOT23
BFR182W	12	35	0.9	19.0	25.0	5.0	8.0	250	SOT323
BFP183W	12	65	0.9	22.0	26.5	8.5	8.0	450	SOT343
BFR183	12	65	0.9	17.5	27.0	9.0	8.0	450	SOT23
BFR183W ¹⁾	12	65	0.9	18.5	27.0	9.0	8.0	450	SOT323
BFR35AP ¹⁾	15	45	1.4	16.0	24.0	9.0	5.0	280	SOT23
BFR92P	15	45	1.4	16.0	24.0	9.0	5.0	280	SOT23
BFR92W ¹⁾	15	45	1.4	17.0	24.0	9.0	5.0	280	SOT323
BFS17P	15	25	3.5	-	21.5	10.0	1.4	280	SOT23
BFS17S	15	25	3.0	12.7	22.5	11.0	1.4	280	SOT363
BFS17W	15	25	3.5	12.7	22.5	11.0	1.4	280	SOT323
BFS481	12	20	0.9	20.0	18.0	-1.0	8.0	175	SOT363
BFS483 ¹⁾	12	65	0.9	19.0	26.5	9.0	8.0	450	SOT363
High Gain up to 2.5GHz, Flatlead TSFP Package Respectively TSLP Package for Modules									
BFR340F	6	10	1.15	16.5	13.0	-1.0	14.0	60	TSFP-3-1
BFR340L3	6	10	1.15	17.5	12.5	-1.0	14.0	60	TSLP-3-7
BFR360F	6	35	1.00	15.5	24.0	9.0	14.0	210	TSFP-3-1
BFR360L3	6	35	1.00	16.0	24.0	9.0	14.0	210	TSLP-3-1

1) Not for new design

Low Noise Si Transistors up to 5GHz

Product Type	V _{CEO} (max) [V]	I _C (max) [mA]	NF _{min} (typ) [dB]	G _{max} (typ) [dB]	OIP3 [dBm]	OP1dB [dBm]	f _T (typ) [GHz]	P _{tot} (max) [mW]	Package
BFP405	4.5	12	1.25	23.0	15.0	5.0	25	55	SOT343
BFP405F	4.5	12	1.25	22.5	14.0	0.0	25	55	TSFP-4-1
BFP410	4.5	40	1.20	21.5	23.5	10.5	25	150	SOT343
BFP420	4.5	35	1.10	21.0	22.0	12.0	25	160	SOT343
BFP420F	4.5	35	1.10	19.5	24.0	10.5	25	160	TSFP-4-1
BFP460	4.5	50	1.10	17.5	27.5	11.5	22	200	SOT343
BFP520	2.5	40	0.95	23.5	25.0	12.0	45	100	SOT343
BFP520F	2.5	40	0.95	22.5	23.5	10.5	45	100	TSFP-4-1
BFP540	4.5	80	0.90	21.5	24.5	11.0	30	250	SOT343
BFP540ESD	4.5	80	0.90	21.5	24.5	11.0	30	250	SOT343
BFP540FESD	4.5	80	0.90	20.0	24.5	11.0	30	250	TSFP-4-1
For Modules in TSLP Package									
BFR460L3	4.5	50	1.10	16.0	27.0	11.5	22	200	TSLP-3-1

Ultra Low Noise SiGe:C Transistors for use up to 12GHz

Product Type	V _{CEO} (max) [V]	I _C (max) [mA]	NF _{min} (typ) [dB]	G _{max} (typ) [dB]	OIP3 [dBm]	Package
Robust Low Noise Broadband Pre-Matched SiGe:C Transistors						
BFP843F	2.25	55	0.90	23.5	23.5	TSFP-4-1
BFR843EL3	2.25	55	0.95	24.0	21.0	TSLP-3-9



RF Transistors

Ultra Low Noise SiGe:C Transistors for use up to 12GHz

Product Type	V _{CEO} (max) [V]	I _C (max) [mA]	NF _{min} (typ) [dB]	G _{max} (typ) [dB]	OIP3 [dBm]	OP1dB [dBm]	f _T (typ) [GHz]	P _{tot} (max) [mW]	Package
Robust Ultra Low Noise SiGe:C Transistors									
BFP640ESD	4.10	50	0.65	25.0	27.0	12.0	46	200	SOT343
BFP640FESD	4.10	50	0.55	26.5	26.0	11.5	46	200	TSFP-4-1
BFP720ESD	4.20	25	0.60	27.0	22.0	6.5	45	100	SOT343
BFP720FESD ¹⁾	4.20	25	0.60	27.0	22.0	7.0	45	100	TSFP-4-1
BFP740ESD	4.20	35	0.60	27.0	25.0	10.0	47	160	SOT343
BFP740FESD	4.20	35	0.60	27.0	24.5	10.0	47	160	TSFP-4-1
BFP840ESD	2.25	35	0.60	27.0	21.0	4.5	80	75	SOT343
BFP840FESD	2.25	35	0.55	27.5	21.0	4.5	85	75	TSFP-4-1
BFP842ESD	3.25	40	0.40	23.5	24.5	8.0	57	120	SOT343
BFR840L3RHESD	2.25	35	0.50	26.5	17.0	4.0	75	75	TSPL-3-9
Ultra Low Noise SiGe:C Transistors									
BFP620	2.30	80	0.70	21.5	25.5	14.5	65	185	SOT343
BFP620F	2.30	80	0.70	21.0	25.0	14.0	65	185	TSFP-4-1
BFP640	4.00	50	0.65	24.0	26.5	13.0	40	200	SOT343
BFP640F	4.00	50	0.65	23.0	27.5	13.5	40	200	TSFP-4-1
BFP720	4.00	20	0.50	26.0	20.5	6.0	45	80	SOT343
BFP720F	4.00	20	0.50	26.0	20.5	6.0	45	80	TSFP-4-1
BFP740	4.00	45	0.50	27.0	25.0	11.0	42	160	SOT343
BFP740F	4.00	45	0.50	27.5	25.0	11.0	42	160	TSFP-4-1
BFR720L3RH ¹⁾	4.00	20	0.50	24.0	20.5	6.0	45	80	TSPL-3-9
BFR740L3RH	4.00	30	0.50	24.5	25.0	11.0	42	160	TSPL-3-9

1) Not for new design

High Linearity Si- and SiGe:C-Transistors for use up to 6GHz

Product Type	V _{CEO} (max) [V]	I _C (max) [mA]	NF _{min} (typ) [dB]	G _{max} (typ) [dB]	OIP3 [dBm]	OP1dB [dBm]	f _T (typ) [GHz]	P _{tot} (max) [mW]	Package
For Low Frequencies, e.g. VHF/UHF									
BF799	20.0	35	3.00	–	–	–	0.8	280	SOT23
BF799W	20.0	35	3.00	–	–	–	0.8	280	SOT323
BFQ19S	15.0	210	1.80	11.5	32.0	22.0	5.5	1000	SOT89
BFR93A	12.0	90	1.50	14.5	30.0	15.0	6.0	300	SOT23
BFR93AW	12.0	90	1.50	15.5	30.0	15.0	6.0	300	SOT323
BFR106	15.0	210	1.80	13.0	32.0	22.0	5.0	700	SOT23
BFP193	12.0	80	1.00	18.0	29.5	15.0	8.0	580	SOT143
BFP193W	12.0	80	1.00	20.5	29.5	15.0	8.0	580	SOT343
BFR193	12.0	80	1.00	15.0	30.0	15.0	8.0	580	SOT23
BFR193F	12.0	80	1.00	19.0	29.0	14.8	8.0	580	TSFP-3-1
BFR193W	12.0	80	1.30	16.0	30.0	15.0	8.0	580	SOT323
BFR193L3	12.0	80	1.00	19.0	29.0	15.0	8.0	580	TSPL-3-1
BFP196(R)	12.0	150	1.30	16.5	32.0	19.0	7.5	700	SOT143
BFP196W	12.0	150	1.30	19.0	32.0	19.0	7.5	700	SOT343
Si Transistors with High Gain up to 2.5GHz									
BFR380F	6.0	80	1.10	13.5	29.0	17.0	14.0	380	TSFP-3-1
BFR380L3	6.0	80	1.10	13.5	29.5	16.0	14.0	380	TSPL-3-1
BFP450	4.5	100	1.25	15.5	29.0	19.0	24.0	450	SOT343
SiGe:C Transistors with High Gain up to 6GHz									
BFP650	4.0	150	0.80	21.5	29.5	18.0	37.0	500	SOT343
BFP650F	4.0	150	0.80	21.5	31.0	17.5	42.0	500	TSFP-4-1
BFP750 ¹⁾	4.0	90	0.90	22.5	30.0	16.0	41.0	360	SOT343
BFR750L3RH ¹⁾	4.0	90	0.60	21.0	29.5	16.5	37.0	360	TSPL-3-9
BFP760	4.0	70	0.50	25.0	31.5	14.5	45.0	240	SOT343

1) Not for new design

Biased Low Noise RF Transistor

Product Type	V _{CEO} (max) [V]	I _C (max) [mA]	NF _{min} (typ) [dB]	G _{max} (typ) [dB]	OIP3 [dBm]	OP1dB [dBm]	f _T (typ) [GHz]	P _{tot} (max) [mW]	Package
BGR405	4.5	12	1.6	7.0	14.5	-0.5	25	50	SOT343
BGR420	4.5	25	1.7	15.5	23.0	7.4	25	120	SOT343

Application notes, Data sheets, Simulation data: www.infineon.com/rftransistors.documents

RF MOSFET

Single Full Biased

Product Type	I_D (max) [mA]	P_{tot} (max) [mW]	g_{fs} (typ) [ms]	G_p (typ) [dB]	F (typ) [dB]	C_{g1ss} (typ) [pF]	C_{dss} (typ) [pF]	Package
BF1005SR	25	200	30	22	1.6	2.4	1.3	SOT143
BF1005R	25	200	24	19	1.6	2.1	1.3	SOT143

Single Non Biased

Product Type	I_D (max) [mA]	P_{tot} (max) [mW]	g_{fs} (typ) [ms]	G_p (typ) [dB]	F (typ) [dB]	C_{g1ss} (typ) [pF]	C_{dss} (typ) [pF]	Package
BF998	30	200	24	20	1.8	2.1	1.1	SOT143

Single Semi Biased

Product Type	I_D (max) [mA]	P_{tot} (max) [mW]	g_{fs} (typ) [mS]	G_p (typ) [dB]	F (typ) [dB]	C_{g1ss} (typ) [pF]	C_{dss} (typ) [pF]	Package
BF2030R	40	200	31	23	1.5	2.4	1.3	SOT143
BF2040	40	200	42	23	1.6	2.9	1.6	SOT143
BF2040W	40	200	42	23	1.6	2.9	1.6	SOT343
BF5020	25	200	34	26	1.2	2.4	1.0	SOT143
BF5020R	25	200	34	26	1.2	2.4	1.0	SOT143
BF5030	25	200	41	24	1.3	2.7	1.6	SOT143
BF5030R	25	200	41	24	1.3	2.7	1.6	SOT143

Dual Semi Biased

Product Type	I_D (max) [mA]	P_{tot} (max) [mW]	g_{fs} (typ) [mS]	G_p (typ) [dB]	F (typ) [dB]	C_{g1ss} (typ) [pF]	C_{dss} (typ) [pF]	Package
BG3130	25	200	33	24	1.3	1.9	1.1	SOT363
BG3130R	25	200	33	24	1.3	1.9	1.1	SOT363

Application notes, Data sheets, Simulation data: www.infineon.com/rfmosfet.documents





RF Pin Diode

Band Switching and RF Attenuation

Product Type	I_F (max) [mA]	C_T (max) [pF]	r_F (typ) [Ω]	τ_{rr} (typ) [ns]	Configuration	Mounting	Package
BA592	100	1.4	0.36	120	Single	SMT	SOD323
BA595	50	0.6	4.50	1600	Single	SMT	SOD323
BA885	50	0.6	4.50	1600	Single	SMT	SOT23
BA892-02V	100	1.4	0.36	120	Single	SMT	SC79
BA895-02V	50	0.6	4.50	1600	Single	SMT	SC79
BAT18-04	100	1.0	0.40	120	Dual	SMT	SOT23
BAT18-05 ¹⁾	100	1.0	0.40	120	Dual	SMT	SOT23
BAR14-1	140	0.5	7.00	1000	Dual	SMT	SOT23
BAR15-1	140	0.5	7.00	1000	Dual	SMT	SOT23
BAR16-1 ¹⁾	140	0.5	7.00	1000	Dual	SMT	SOT23
BAR61 ¹⁾	140	0.5	7.00	1000	Single	SMT	SOT143

1) Not for new design



www.infineon.com/pindiodes

Antenna Switch

Product Type	I_F (max) [mA]	C_T (max) [pF]	r_f (typ) [Ω]	τ_{rr} (typ) [ns]	Configuration	Mounting	Package
BAR50-02L ¹⁾	100	0.50	3.00	1100	Single	SMT	TSLP-2-1
BAR50-02V	100	0.50	3.00	1100	Single	SMT	SC79
BAR50-03W ²⁾	100	0.50	3.00	1100	single	-	SOD323
BAR63-02L ¹⁾	100	0.30	1.00	75	Single	SMT	TSLP-2-1
BAR63-02V	100	0.30	1.00	75	Single	SMT	SC79
BAR63-03W	100	0.30	1.00	75	Single	SMT	SOD323
BAR63-04	100	0.30	1.00	75	Dual	SMT	SOT23
BAR63-04W	100	0.30	1.00	75	Dual	SMT	SOT323
BAR63-05	100	0.30	1.00	75	Dual	SMT	SOT23
BAR63-05W	100	0.30	1.00	75	Dual	SMT	SOT323
BAR63-06	100	0.30	1.00	75	Dual	SMT	SOT23
BAR63-06W	100	0.30	1.00	75	Dual	SMT	SOT323
BAR64-02EL	100	0.35	2.10	1550	Single	SMT	TSLP-2-19
BAR64-02V	100	0.35	2.10	1550	Single	SMT	SC79
BAR64-04W	100	0.35	2.10	1550	Dual	SMT	SOT323
BAR64-05W	100	0.35	2.10	1550	Dual	SMT	SOT323
BAR64-03W	100	0.35	2.10	1550	Single	SMT	SOD323
BAR64-04	100	0.35	2.10	1550	Dual	SMT	SOT23
BAR64-05	100	0.35	2.10	1550	Dual	SMT	SOT23
BAR64-06	100	0.35	2.10	1550	Dual	SMT	SOT23
BAR64-06W	100	0.35	2.10	1550	Dual	SMT	SOT323
BAR65-02V	100	0.90	0.56	80	Single	SMT	SC79
BAR65-03W	100	0.90	0.56	80	Single	SMT	SOD323
BAR67-02V	200	0.55	1.00	700	Single	SMT	SC79
BAR67-04	200	0.90	1.50	700	Dual	-	SOT23
BAR81W	100	1.00	0.70	80	Single	SMT	SOT343
BAR86-02EL	100	0.15 ²⁾	3.70 ²⁾	3 ²⁾	Single	SMT	TSLP-2
BAR86-02ELS	100	0.15 ²⁾	3.70 ²⁾	3 ²⁾	Single	SMT	TSSLP-2
BAR88-02LRH ¹⁾	100	0.40	0.60	500	Single	SMT	TSLP-2-7, -17, -21
BAR88-02V	100	0.40	0.60	500	Single	SMT	SC79
BAR89-02LRH ¹⁾	100	0.35	0.80	800	Single	SMT	TSLP-2-7, -17, -21
BAR90-02EL	100	0.35	0.80	750	Single	SMT	TSLP-2-19
BAR90-02ELS	100	0.35	0.80	750	Single	SMT	TSSLP-2-3, -4
BAR90-098LRH ³⁾	100	0.35	0.80	750	Dual	SMT	TSLP-4-7

1) Not for new design

2) Typical value

3) On request

Application notes, Data sheets, Simulation data: www.infineon.com/pindiodes.documents



GOLDEN LION
Table 14

- Wine Syrah
- Wine Chardonnay 2x 9.60
- Water 1x 8.40
- Sweet and Sour Pork Ribs 3x 5.80
- Sauteed Prawns 1x 16.60
- Sweet and Sour Deep Fried Garoupa 2x 18.40
- Sauteed Diced Wagyu Beef 2x 28.00
- Chilled Mango Cream 1x 42.00
- Boiled 1x 15.60
- 2x 17.50

served by Brian 16:30

Customer 01 0.00 \$ Bill

Customer 02 76.20 \$ Bill

Customer 03 0.00 \$ Bill

Remain 247.00
\$ 170.80

Bill

Edit Add

RF Varactor Diode

VCO and Low Voltage Tuner

Product Type	Configuration	I_F (max) [mA]	C_{T1} (typ) [pF]	C_{T2} (typ) [pF]	C_T/C_T	r_s (typ) [Ω]	Mounting	Package
BBY51-03W	Single	20	5.40	4.20	1.75 (1/4V)	0.37	SMT	SOD323
BBY52-02L ¹⁾	Single	20	1.85	1.50	1.60 (1/4V)	0.90	SMT	TSLP-2-1
BBY53-02L ¹⁾	Single	20	5.30	2.40	2.20 (1/3V)	0.47	SMT	TSLP-2-1
BBY53-02V	Single	20	5.30	2.40	2.20 (1/3V)	0.47	SMT	SC79
BBY53-03LRH	Single	20	5.30	2.40	2.20 (1/3V)	0.47	SMT	TSLP-3-7
BBY53-03W	Single	20	5.30	2.40	2.20 (1/3V)	0.47	SMT	SOD323
BBY53-05W	Dual	20	5.30	2.40	2.20 (1/3V)	0.47	SMT	SOT323
BBY55-02V	Single	20	18.60	15.00	2.50 (2/10V)	0.15	SMT	SC79
BBY55-03W	Single	20	18.60	15.00	2.50 (2/10V)	0.15	SMT	SOD323
BBY56-03W ¹⁾	Single	20	5.30	2.40	2.20 (1/3V)	0.47	-	SOD323
BBY57-02V	Single	20	17.50	8.00	2.45 (1/3V)	0.30	SMT	SC79
BBY57-05W	Dual	20	17.50	10.00	2.45 (1/3V)	0.30	SMT	SOT323
BBY58-02V	Single	20	18.30	12.35	2.15 (1/3V)	0.25	SMT	SC79
BBY58-03W	Single	20	18.30	12.35	2.15 (1/3V)	0.25	SMT	SOD323
BBY58-05W	Dual	20	18.30	12.35	2.15 (1/3V)	0.25	SMT	SOT323
BBY58-06W	Dual	20	18.30	12.35	2.15 (1/3V)	0.25	SMT	SOT323
BBY65-02V	Single	50	20.25	9.80	4.55 (1/3V)	0.60	SMT	SC79
BBY66-02V	Single	50	68.70	35.40	5.41 (1/4.5V)	0.25	-	SC79
BBY66-05W	Dual	50	68.70	35.40	5.41 (1/4.5V)	0.25	SMT	SOT323

1) Not for new design

FM Tuner

Product Type	Configuration	I_F (max) [mA]	C_{T1} (typ) [pF]	C_{T2} (typ) [pF]	C_T/C_T	r_s (typ) [Ω]	Mounting	Package
BB804	Dual	50	47.50	27.9	1.71 (2/8V)	0.18	SMT	SOT23
BB814	Dual	50	44.75	20.8	2.15 (2/8V)	0.18	SMT	SOT23
BB844	Single	50	43.75	11.7	3.80 (2/8V)	0.28	SMT	SOT23
BB914	Dual	50	43.75	18.7	2.34 (2/8V)	0.28	SMT	SOT23

SAT Tuner

Product Type	Configuration	I_F (max) [mA]	C_{T1} (typ) [pF]	C_T/C_T	r_s (typ) [Ω]	Mounting	Package
BB833	Single	20	9.3	12.4 (1/28V)	1.8	SMT	SOD323
BB837	Single	20	6.6	12.7 (1/28V)	1.5	SMT	SOD323
BB857-02V	Single	20	6.6	12.7 (1/28V)	1.5	SMT	SC79

UHF and VHF Tuner

Product Type	Configuration	I_F (max) [mA]	C_{T1} (typ) [pF]	C_{T2} (typ) [pF]	C_T/C_T	r_s (typ) [Ω]	Mounting	Package
BB439	Single	20	43.0	34.50	6.9 (2/25V)	0.35	SMT	SOD323
BB545	Single	20	20.0	14.80	7.2 (2/25V)	0.60	SMT	SOD323
BB640	Single	20	69.0	54.50	16.6 (2/25V)	1.15	SMT	SOD323

Application notes, Data sheets, Simulation data: www.infineon.com/varactordiodes.documents



RF Mixer + Detector Schottky Diode

Product Type	V_R (max) [V]	I_F (max) [mA]	C_T (typ) [pF]	V_F (typ) [V]	Configuration	R_o @ $V_R = 0V$ [k Ω]	Package
RF Mixer							
BAT15-02EL	4	110	0.26	0.230	Single	–	TSLP-2
BAT15-02ELS	4	110	0.26	0.230	Single	–	TSSLP-2
BAT15-03W	4	110	0.26	0.230	Single	–	SOD323
BAT15-04R	4	110	0.26	0.230	Single	–	SOT23
BAT15-04W	4	110	0.26	0.230	Dual	–	SOT323
BAT15-05W	4	110	0.26	0.230	Dual	–	SOT323
BAT15-099	4	110	0.26	0.230	Single	–	SOT143
BAT17	4	130	0.55	0.340	Single	–	SOT23
BAT17-04	4	130	0.55	0.340	Dual	–	SOT23
BAT17-04W	4	130	0.55	0.340	Dual	–	SOT323
BAT17-05	4	130	0.55	0.340	Dual	–	SOT23
BAT17-05W	4	130	0.55	0.340	Dual	–	SOT323
BAT17-06W	4	130	0.55	0.340	Dual	–	SOT323
BAT17-07	4	130	0.75	0.340	Dual	–	SOT143
BAT24-02ELS	4	110	0.21	0.230	Single	–	TSSLP-2-1
RF Signal Detection + Power Leveling							
BAT62	40	20	0.35	0.580	Dual	225	SOT143
BAT62-02LS	40	20	0.35	0.580	Single	225	TSSLP-2-1
BAT62-02V	40	20	0.35	0.580	Single	225	SC79
BAT62-03W	40	20	0.35	0.580	Single	225	SOD323
BAT62-07W	40	20	0.35	0.580	Dual	225	SOT343
BAT63-02V	3	100	0.65	0.190	Single	30	SC79
BAT63-07W	3	100	0.65	0.190	Dual	30	SOT343
BAT68	8	130	0.75	0.318	Single	–	SOT23
BAT68-04	8	130	0.75	0.318	Dual	–	SOT23
BAT68-04W	8	130	0.75	0.318	Dual	–	SOT323
BAT68-06	8	130	0.75	0.318	Dual	–	SOT23
BAT68-06W	8	130	0.75	0.318	Dual	–	SOT323

Application notes, Data sheets, Simulation data: www.infineon.com/schottkydiodes.documents



www.infineon.com/schottkydiodes



RF mmW-MMIC

24GHz Industrial

Product Type	f [GHz]	I _{cc} (typ) [mA]	P _{TX} (typ) [dBm]	Gain (typ) [dB]	NF _{min} (typ) [dB]	Compression Point P _{1dB} (typ)	Frequency Divider	Temperatur Sensor	Package
BGT24MR2	24–24.25	90	–	26	12	-12	no	yes	VQFN-32-9
BGT24MTR11	24–26.00	150	11	26	12	-12	yes	yes	VQFN-32-9
BGT24MTR12	24–24.25	210	11	26	12	-12	yes	yes	VQFN-32-9

Backhaul

Product Type	f [GHz]	P _{sat} (typ) [dBm]	Rx Gain (typ) [dB]	NF _{DSB} (typ) [dB]	I _{ccRx} /T _x	PN @ 100kHz (typ) [dBc/Hz]	Power Detector	Temperatur Sensor	Package
BGT60	57–64	14	22	7	350/480mA @ 3.3V	-81	Integrated	Integrated	WFWLB-119-1
BGT70	71–76	14	20	8	350/480mA @3.3V	-80	Integrated	Integrated	WFWLB-119-1
BGT80	81–86	10	20	9	350/480mA @ 3.3V	-80	Integrated	Integrated	WFWLB-119-1

Application notes, Data sheets, Simulation data: www.infineon.com/mmWave.documents





ESD & EMI Protection and Filters

Multi-Purpose ESD Devices

Product Type	Applications	V_{RWM}		C_L (typ,max)		V_{ESDmax}	
		[V]	[V]	[pF]	[pF]	[kV]	[kV]
ESD200-B1-CSP0201	keypad, touchscreen, buttons, convenience keys, audio	-5.5	5.5	6.5	-	-16	16
ESD201-B2-03LRH	keypad, touchscreen, buttons, Audio	-5.5	5.5	5.0	7.0	-20	20
ESD202-B1-CSP01005	keypad, touchscreen, buttons, Audio	-5.5	5.5	5.5	7.0	-12	12
ESD203-B1-02ELS	Audio Line, Speaker, Headset, Microphone Protection, Human Interface Devices	-12.0	12.0	6.0	-	-30	30
ESD203-B1-02EL	Audio Line, Speaker, Headset, Microphone Protection, Human Interface Devices	-12.0	12.0	6.0	-	-30	30
ESD204-B1-02ELS	keypad, touchscreen, buttons, convenience keys	-8.0	14.0	4.0	7.0	-15	15
ESD204-B1-02EL	keypad, touchscreen, buttons, convenience keys	-8.0	14.0	4.0	7.0	-15	15
ESD205-B1-02ELS	keypad, touchpad, buttons, convenience keys	-5.5	5.5	4.0	7.0	-20	20
ESD205-B1-02EL	keypad, touchpad, buttons, convenience keys	-5.5	5.5	4.0	7.0	-20	20
ESD206-B1-02ELS	Audio Line, Speaker, Headset, Microphone Protection, Human Interface Devices	-5.5	5.5	13.0	-	-30	30
ESD206-B1-02EL	Audio Line, Speaker, Headset, Microphone Protection, Human Interface Devices	-5.5	5.5	13.0	-	-30	30
ESD206-B1-02V	Aaudio line, speaker, microphone, human interfaces	-5.5	5.5	13.0	-	-30	30
ESD207-B1-02ELS	keypad, touchpad, buttons, convenience keys	-3.3	3.3	14.0	20.0	-30	30
ESD207-B1-02EL	keypad, touchpad, buttons, convenience keys	-3.3	3.3	14.0	20.0	-30	30
ESD208-B1-02ELS	keypad, touchpad, buttons, convenience keys	-3.3	3.3	6.0	9.0	-25	25
ESD208-B1-02EL	keypad, touchpad, buttons, convenience keys	-3.0	3.0	6.0	9.0	-25	25
ESD217-U1-02EL	keypad, touchpad, buttons, convenience keys	-8.0	14.0	8.5	13.0	-25	25
ESD218-B1-02ELS	keypad, touchpad, buttons, convenience keys, USB Vbus	-24.0	24.0	2.5	3.5	-18	18
ESD218-B1-02EL	keypad, touchpad, buttons, convenience keys, USB Vbus	-24.0	24.0	2.5	3.5	-18	18
ESD221-U1-02EL	keypad, touchpad, buttons, convenience keys	5.3	-	35.0	40.0	25	-
ESD5V0L1B-02V	keypad, touchscreen, buttons, Power Lines	-5.0	5.0	8.5	13.0	25	-
ESD5V0S1U-02V	keypad, touchscreen, buttons, Power Lines	5.0	-	35.0	40.0	20	-
ESD24VS2U	keypad, touchscreen, buttons, 24V Appls.	24.0	-	48.0	52.0	30	-

Application notes, Data sheets, Simulation data: www.infineon.com/esd.documents



www.infineon.com/esdprotection



$R_{DYN,typ\ reverse}$ [Ω]	$R_{DYN,typ\ forward}$ [Ω]	$V_{cl\ typ.\ reverse}$ TLP 16A [V]	$V_{cl\ typ.\ forward}$ TLP 16A [V]	$V_{cl\ typ.\ reverse}$ TLP 30A [V]	$V_{cl\ typ.\ forward}$ TLP 30A [V]	$I_R\ (max)$ [nA]	I_{EFT} [A]	I_{surge} [A]	Protected Lines	Package
0.2	0.2	13.0	13.0	-	-	100	-	3.0	1	WLL-2-1
0.37	0.22	12.1	10.2	-	-	100	40	2.5	2	TSLP-3-9
0.20	0.20	13.0	13.0	17.0	17.0	100	-	3.0	1	WLL-2-2
0.29	0.29	17.0	18.0	23.0	23.5	50	50	5.0	1	TSSLP-2-4
0.29	0.29	17.0	18.0	23.0	23.5	50	50	5.0	1	TSLP-2-20
0.6	0.5	28.0	28.0	35.0	35.0	50	40	1.0	1	TSSLP-2-3
0.6	0.5	28.0	28.0	35.0	35.0	50	40	1.0	1	TSLP-2-19
0.22	0.37	10.2	12.1	13.2	17.2	100	40	2.5	1	TSSLP-2-3
0.22	0.37	10.3	12.2	13.3	17.3	100	40	2.5	1	TSLP-2-19
0.15	0.15	9.0	9.0	11.0	11.0	100	50	6.0	1	TSSLP-2-3
0.15	0.15	9.0	9.0	11.0	11.0	100	50	6.0	1	TSLP-2-19
0.15	0.15	9.0	9.0	11.0	11.0	100	50	6.0	1	SC79
0.13	0.13	7.0	7.0	9.0	9.0	50	40	8.0	1	TSSLP-2-3
0.13	0.13	7.0	7.0	9.0	9.0	50	40	8.0	1	TSLP-2-19
0.2	0.2	8.0	8.0	11.0	11.0	50	80	4.0	1	TSSLP-2-3
0.2	0.2	8.0	8.0	11.0	11.0	50	80	4.0	1	TSLP-2-19
0.3	0.2	28.0	26.0	30.0	27.0	50	40	2.5	1	TSLP-2-19
1.0	1.0	55.0	55.0	-	-	50	40	1.0	1	TSSLP-2-4
1.0	1.0	55.0	55.0	-	-	50	40	1.0	1	TSLP-2-20
0.27	0.27	7.0	1.2	9.0	2.5	100	50	5.5	1	TSLP-2-20
0.4	0.2	22.0	25.0	26.0	27.0	50	40	2.5	1	SC79
0.2	0.3	10.5	4.3	14.5	7.3	100	50	5.5	1	SC79
0.22	0.11	37.0	2.6	40.0	4.2	10 μ A	80	5.0	2	SOT23

ESD & EMI Protection and Filters

Low Capacitance ESD Devices

Product Type	Applications	V_{RWM}		C_L (typ,max)		V_{ESDmax}	
		[V]		[pF]		[kV]	
ESD101-B1-02ELS	Super high-speed interfaces, RF antennas	-5.5	5.5	0.1	0.2	-10	10
ESD101-B1-02EL	RF antenna, Super high-speed interfaces such as USB 3.0, HDMI 1.4a, MHL	-5.5	5.5	0.1	0.2	-12	12
ESD102-U1-02ELS	USB 3.0, 10/100/1000 Ethernet, Firewire, DVI, HDMI, S-ATA, DisplayPort	3.3	-	0.4	0.65	-20	20
ESD102-U2-099EL	USB 3.0, 10/100/1000 Ethernet, firewire, DVI, HDMI, S-ATA, display port	3.3	-	0.4	0.65	-20	20
ESD102-U4-05L	Protection of high-speed digital interfaces	3.3	-	0.4	0.65	-20	20
ESD103-B1-02ELS	Super high-speed interfaces, RF antenna	-15.0	15.0	0.1	0.2	-10	10
ESD103-B1-02EL	RF antenna, Super high-speed interfaces such as USB 3.0, HDMI 1.4a, MHL	-15.0	15.0	0.09	0.2	-10	10
ESD105-B1-02ELS	RF antenna, Super high-speed interfaces such as USB 3.0, HDMI 1.4a, MHL	-5.5	5.5	0.3	0.45	-25	25
ESD105-B1-02EL	RF antenna, Super high-speed interfaces such as USB 3.0, HDMI 1.4a, MHL	-5.5	5.5	0.3	0.45	-25	25
ESD108-B1-CSP0201	RF antenna, small signal, NFC	-5.5	5.5	0.28	0.38	-25	25
ESD110-B1-02ELS	RF antenna, small signal, NFC	-18.5	18.5	0.3	0.6	-15	15
ESD110-B1-02EL	RF antenna, small signal, NFC	-18.5	18.5	0.3	0.6	-15	15
ESD112-B1-02ELS	RF antenna, small signal, NFC	-5.3	5.3	0.23	0.4	-20	20
ESD112-B1-02EL	RF antenna, small signal, NFC	-5.3	5.3	0.23	0.4	-20	20
ESD113-B1-02ELS	HDMI, USB 2.0, USB 3.0, DisplayPort, DVI	-3.6	3.6	0.22	-	-20	20
ESD113-B1-02ELS	HDMI, USB 2.0, USB 3.0, DisplayPort, DVI	-3.6	3.6	0.22	-	-20	20
ESD114-U1-02ELS	RF antenna, Super high-speed interfaces such as USB 3.0, HDMI 1.4a, MHL	5.3	-	0.4	0.6	20	-
ESD114-U1-02EL	RF antenna, Super high-speed interfaces such as USB 3.0, HDMI 1.4a, MHL	5.3	-	0.4	0.6	20	-
ESD3V3U4ULC	USB3.0	3.3	-	0.4	0.65	20	-
ESD5V3U2U-03F	USB2.0, HDMI, DisplayPort	5.3	-	0.4	0.6	20	-
ESD5V3U4U-HDMI	USB2.0, HDMI, DisplayPort	5.3	-	0.4	0.6	20	-
ESD5V3U4RRS	USB2.0	5.3	-	0.4	0.6	15	-
ESD5V5U5ULC	USB2.0 x 2 (4 I/O + Vcc)	5.5	-	0.45	1.0	25	-
ESD0P8RFL	RF antenna, small signal, NFC	-50.0	50.0	0.8	-	20	-

Surge Protection Devices

Product Type	Applications	V_{RWM}		C_L (typ,max)		V_{ESDmax}	
		[V]		[pF]		[kV]	
ESD300-B1-02LRH	Keypad, touchscreen, buttons, power lines	-3.3	3.3	1.2	-	-30	30
ESD307-U1-02N	VBUS	10.0	-	270.0	350	-30	30
ESD311-U1-02N	VBUS	15.0	-	-	-	-30	30
DSL70	DSL	50.0	-	2.5	5	-15	15
TVS3V3L4U	Gigabit Ethernet	3.3	-	2.0	3	-30	30

Application notes, Data sheets, Simulation data: www.infineon.com/esd.documents

$R_{DYN,typ\ reverse}$ [Ω]	$R_{DYN,typ\ forward}$ [Ω]	$V_{cl\ typ,\ reverse}$ TLP 16A [V]	$V_{cl\ typ,\ forward}$ TLP 16A [V]	$V_{cl\ typ,\ reverse}$ TLP 30A [V]	$V_{cl\ typ,\ forward}$ TLP 30A [V]	$I_R\ (max)$ [nA]	I_{EFT} [A]	I_{surge} [A]	Protected Lines	Package
1.3	1.3	29	29	–	–	50	–	–	1	TSSLP-2-3
1.5	1.5	30	30	–	–	50	–	–	1	TSLP-2-20
0.19	0.23	8	6	11	9	50	50	3	1	TSSLP-2-3
0.19	0.23	8	6	11	9	50	50	3	2	TSLP-4-10
0.19	0.23	8	6	11	9	50	50	3	4	TSLP-5-2
1.8	1.8	48	48	–	–	50	–	–	1	TSSLP-2-4
1.8	1.8	48	48	–	–	50	–	–	1	TSLP-2-20
0.38	0.38	13	13	19	19	50	50	5	1	TSSLP-2-4
0.38	0.38	13	13	19	19	50	50	5	1	TSLP-2-20
0.75	0.75	20	20	30	30	100	40	2.5	1	WLL-2-1
0.6	0.6	26	26	35	35	30	–	2	1	TSSLP-2-4
0.6	0.6	26	26	35	35	30	–	2	1	TSLP-2-20
1.0	1.0	29	29	38	38	50	40	3	1	TSSLP-2-4
1.0	1.0	29	29	38	38	50	40	3	1	TSLP-2-20
0.45	0.45	14	12	20	18	50	50	3	1	TSSLP-2-4
0.45	0.45	14	12	20	18	50	50	3	1	TSLP-2-20
0.6	0.5	19	10	28	17	50	50	3	1	TSSLP-2-3
0.6	0.5	19	10	28	17	50	50	3	1	TSLP-2-19
0.19	0.23	8	6	11	9	50	50	3	4	TSLP-9-1
0.6	0.5	19	10	28	17	50	40	3	2	TSFP-3-1
0.6	0.5	19	10	28	17	50	50	3	4	TSLP-9-1
0.62	0.44	20	12	28	17	100	50	3	5	SOT363
0.2	0.3	8.9	5.4	11.5	9.2	100	50	6	5	SC74
–	–	–	–	–	–	100	40	10	1	TSLP-4-7

$R_{DYN,typ\ reverse}$ [Ω]	$R_{DYN,typ\ forward}$ [Ω]	$V_{cl\ typ,\ reverse}$ TLP 16A [V]	$V_{cl\ typ,\ forward}$ TLP 16A [V]	$V_{cl\ typ,\ reverse}$ TLP 30A [V]	$V_{cl\ typ,\ forward}$ TLP 30A [V]	$I_R\ (max)$ [nA]	I_{EFT} [A]	I_{surge} [A]	Protected Lines	Package
0.23	0.23	9.5	9.5	12.5	12.5	100	–	18	1	TSLP-2-21
0.05	–	17.0	–	18.0	–	100	80	34	1	TSNP-2-2
0.07	–	22.0	–	23.0	–	100	80	28	1	TSNP-2-2
0.1	–	2.6 + Vcc	–	4.0 + Vcc	–	5	80	27	2	SOT143
0.09	0.12	5.8	3.1	7.3	4.4	50	80	20	4	SC74













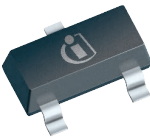
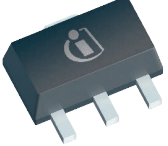
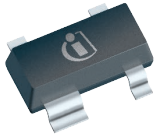









Alphanumerical List of the Symbols used

Symbols	Terms
ANT	Antenna
C_{dss}	Output capacitance
C_{g1ss}	Gate-1 input capacitance
C_L	Line capacitance
C_{OFF}	Off capacitance
C_T	Total diode capacitance
ESD	Electrostatic discharge
F	Noise factor
f	Frequency
f_T	Transition frequency
g_{fs}	Forward transconductance
G_{max}	Max. available gain
G_p	Power gain
I	Current
I_C	Collector current (DC or average value)
I_{CCTx}	Transmitter current consumption
I_{CCRx}	Receiver current consumption
I_D	Drain current
I_{EFT}	Burst current (acc. to IEC61000-4-4)
I_F	Forward current
I_{surge}	Surge current (acc. to IEC61000-4-5)
NF_{DSB}	Double-side band noise figure
NF_{min}	Mimimum noise figure
H2	2 nd Harmonic
H3	3 rd Harmonic

Symbols	Terms
OIP3	Output 3 rd -order intercept point
OP1dB	Output -1dB compression
P_{1dB}	Power output at -1dB compression point
P_{max}	Maximum power
P_{sat}	Saturation power
P_{tot}	Total power dissipation
P_{TX}	Transmitter power
$R_{DYN,typ forward}$	Forward dynamic resistance
$R_{DYN,typ reverse}$	Reverse dynamic resistance
r_F	Forward resistance of diodes
R_O	Differential resistance
R_{ON}	On resistance
r_S	Series resistance
Rx Gain	Receiver gain
τ_{rr}	Charge carrier life time
V_{CC}	Collector supply voltage
V_{CEO}	Collector-emitter breakdown voltage with open base
$V_{cl typ. forward}$	Forward clamping voltage
$V_{cl typ. reverse}$	Reverse clamping voltage
V_{ESDmax}	Voltage of ESD pulse
V_F	Forward voltage
V_R	Reverse voltage
V_{RF}	Maximum RF voltage
V_{RWM}	Reverse working voltage

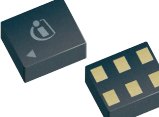

Package Information

SC74		SC79 (SC-79)		SOD323 (SC76)		SOT23 (SOT-23)		SOT89 (SC62, SOT-89)	
6	2.9 x 2.5 x 1.1	2	1.6 x 0.8 x 0.55	2	2.5 x 1.25 x 0.9	3	2.9 x 2.4 x 1	4	4.5 x 4.0 x 1.5
									
6:1		6:1		6:1		6:1		4:1	
SOT143 (SC61)		SOT323 (SC70, SOT-323)		SOT343 (SC82)		SOT363 (SC88, SOT-363)		TSFP-3-1, -2	
4	2.9 x 2.4 x 1.0	3	2.0 x 2.1 x 0.9	4	2.0 x 2.1 x 0.9	6	2.0 x 2.1 x 0.9	3	1.2 x 1.2 x 0.55
									
6:1		6:1		6:1		6:1		8:1	
TSFP-4-1, -2		TSLP-2-1		TSLP-2-7, -17, -21		TSLP-2-19, -20		TSLP-3-1 (SC-101)	
4	1.4 x 1.2 x 0.55	2	1.0 x 0.6 x 0.4	2	1.0 x 0.6 x 0.39	2	1.0 x 0.6 x 0.31	3	1.0 x 0.6 x 0.4
									
8:1		8:1		8:1		8:1		8:1	
TSLP-3-7		TSLP-3-9		TSLP-4-7		TSLP-4-10		TSLP-5-2	
3	1.0 x 0.6 x 0.39	3	1.0 x 0.6 x 0.31	4	1.2 x 0.8 x 0.39	4	0.75 x 0.75 x 0.31	5	1.3 x 0.8 x 0.39
									
8:1		8:1		8:1		8:1		8:1	
TSLP-6-2		TSLP-6-3		TSLP-6-4		TSLP-7-1		TSLP-7-4	
6	1.1 x 0.7 x 0.39	6	1.1 x 0.9 x 0.39	6	1.1 x 0.7 x 0.31	7	2.0 x 1.3 x 0.4	7	2.3 x 1.5 x 0.4
									
8:1		8:1		8:1		6:1		6:1	

 **RoHS** All products are available in green (RoHS compliant).

Footprints are recommendations only.

For detailed information please refer to our datasheets or www.infineon.com/packages.

TSLP-7-6		TSLP-9-1		TSLP-9-3		TSLP-10-1		TSLP-12-4	
7	1.4 x 1.26 x 0.39	9	2.3 x 1 x 0.31	9	1.15 x 1.15 x 0.31	10	1.55 x 1.15 x 0.39	12	1.9 x 1.1 x 0.39
									
6:1		6:1		6:1		6:1		6:1	
TSLP-16-1		TSNP-2-2		TSNP-6-2		TSNP-7-1		TSNP-7-6	
16	2.3 x 2.3 x 0.39	2	1.6 x 0.8 x 0.4	6	1.1 x 0.7 x 0.375	7	2.0 x 1.3 x 0.375	7	1.4 x 1.26 x 0.375
									
5:1		8:1		8:1		6:1		6:1	
TSNP-7-10		TSNP-9-1		TSNP-10-1		TSNP-14-3		TSNP-16-1	
7	2.3 x 1.7 x 0.73	9	1.5 x 1.1 x 0.77	10	1.5 x 1.1 x 0.4	14	2.0 x 2.0 x 0.77	16	2.3 x 2.3 x 0.375
									
5:1		6:1		6:1		5:1		5:1	
TSNP-16-6		TSNP-26-2		TSNP-26-3		TSSLP-2-1, -2		TSSLP-2-3, -4	
16	2.3 x 2.3 x 0.73	26	3.4 x 2.6 x 0.73	26	3.2 x 2.8 x 0.77	2	0.62 x 0.32 x 0.31	2	0.62 x 0.32 x 0.31
									
5:1		4:1		4:1		20:1		20:1	
VQFN-32-9, -15		WFVLB-119-1		WLL-2-1		WLL-2-2		Package (JEITA-code)	
32	5.5 x 4.5 x 0.9	119	6.0 x 6.0 x 0.8	2	0.58 x 0.21 x 0.15	2	0.43 x 0.23 x 0.15	X	L x W x H
								  All Dimensions in mm	
3:1		3:1		20:1		20:1			

SC74

Package Outline

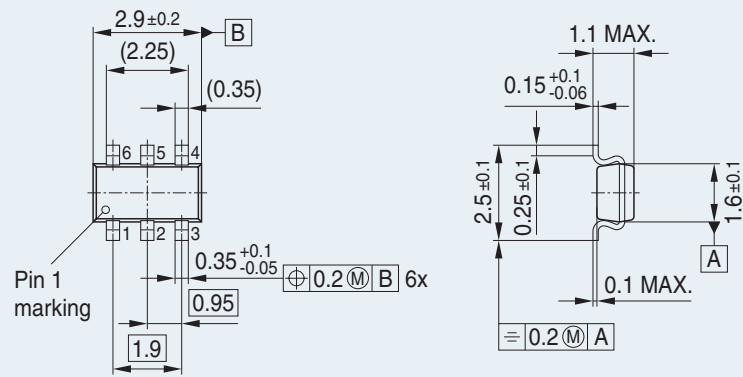

Foot Print (Reflow)

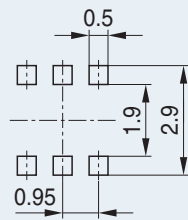

SC79 (SC-79)

Package Outline

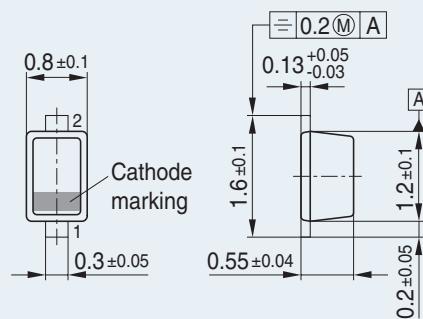

Foot Print

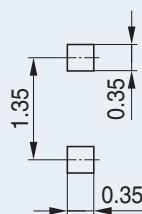

SOD323 (SC76)

Package Outline

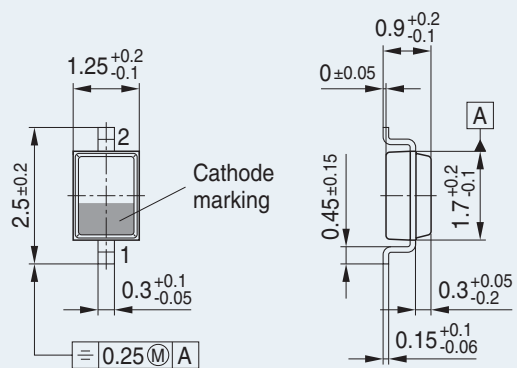

Foot Print (Reflow)

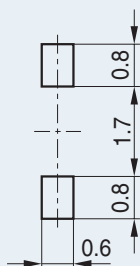

SOT143 (SC61)

Package Outline

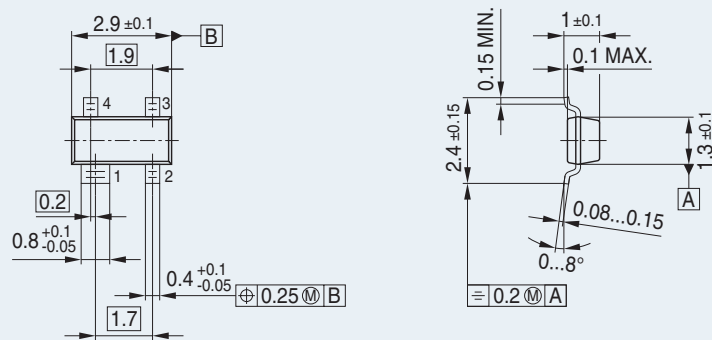

Note: Mold flash, protrusions or gate burrs of 0,2 mm max. per side are not included

Foot Print (Reflow)

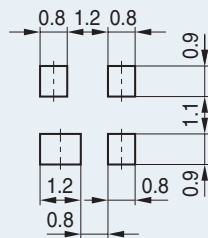

SOT323 (SC70, SOT-323)

Package Outline

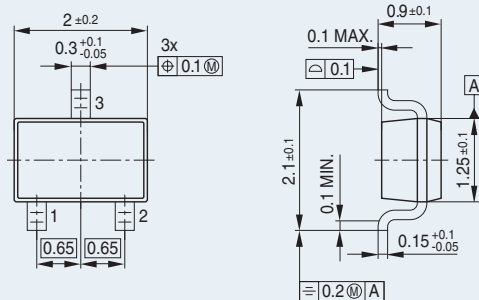

Foot Print (Reflow)

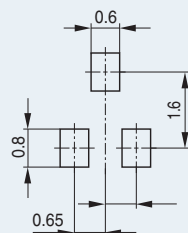

SOT343 (SC82)

Package Outline

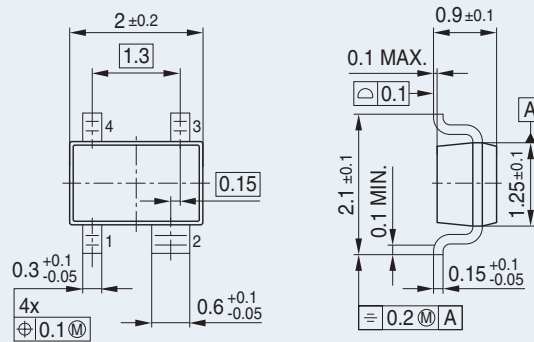

Foot Print

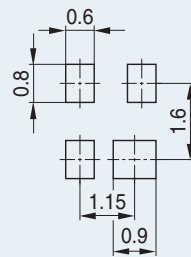

SOT363 (SC88, SOT-363)

Package Outline

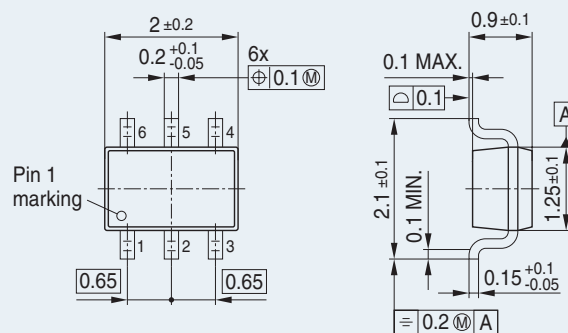

Foot Print

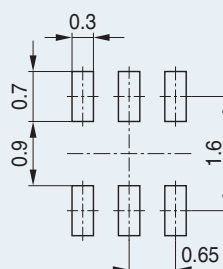

TSFP-3-1, -2

Package Outline

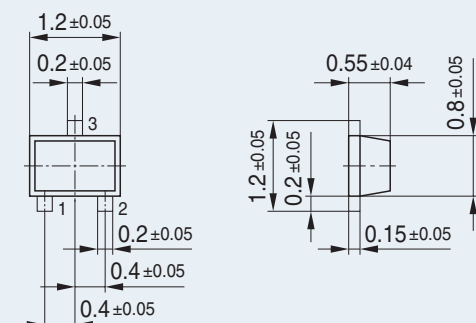

Foot Print

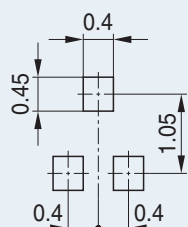

TSFP-4-1, -2

Package Outline

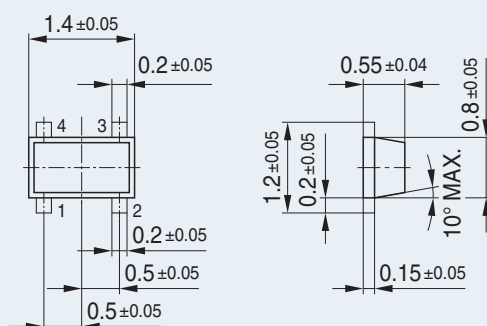

Foot Print

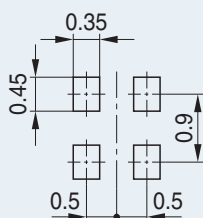

TSLP-2-1

Package Outline

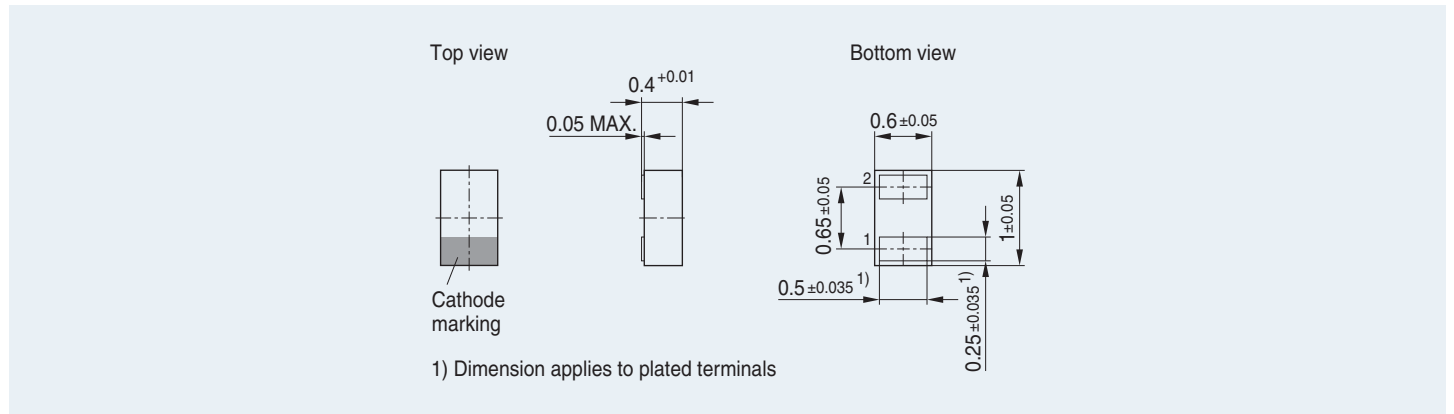

Foot Print

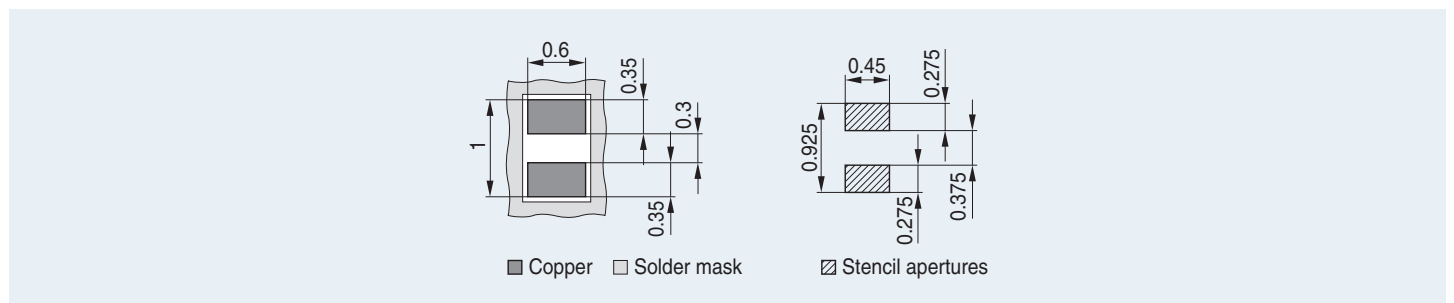

TSLP-2-7, -17, -21

Package Outline

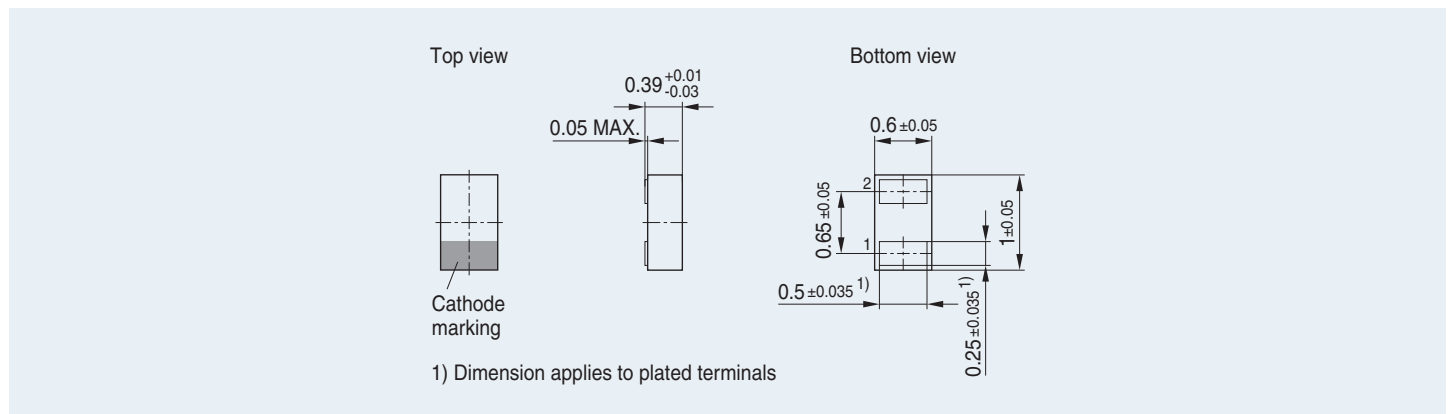

Foot Print

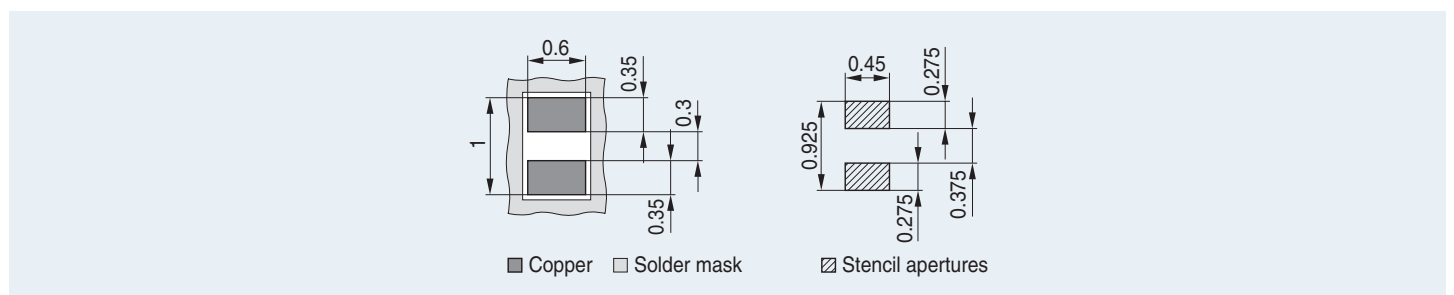

TSLP-2-19, -20

Package Outline

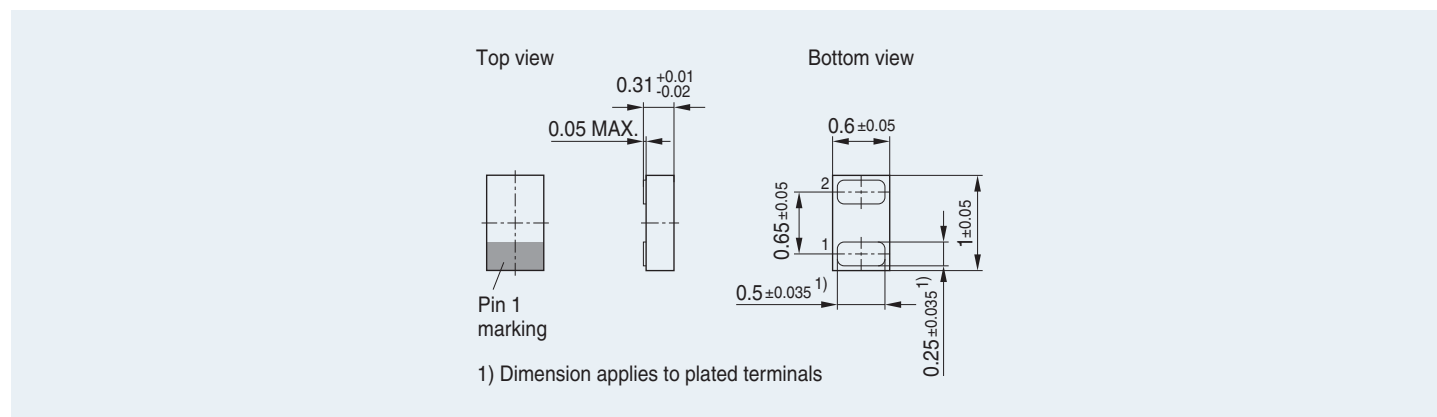

Foot Print

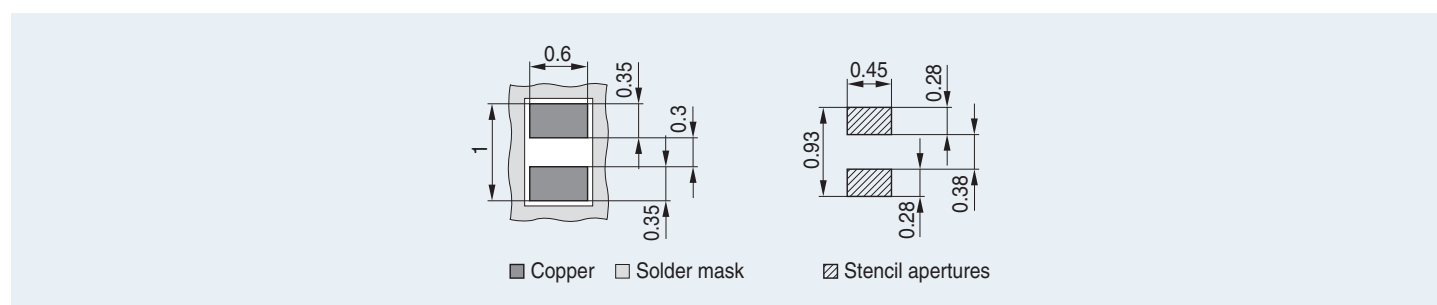

TSLP-3-1 (SC-101)

Package Outline

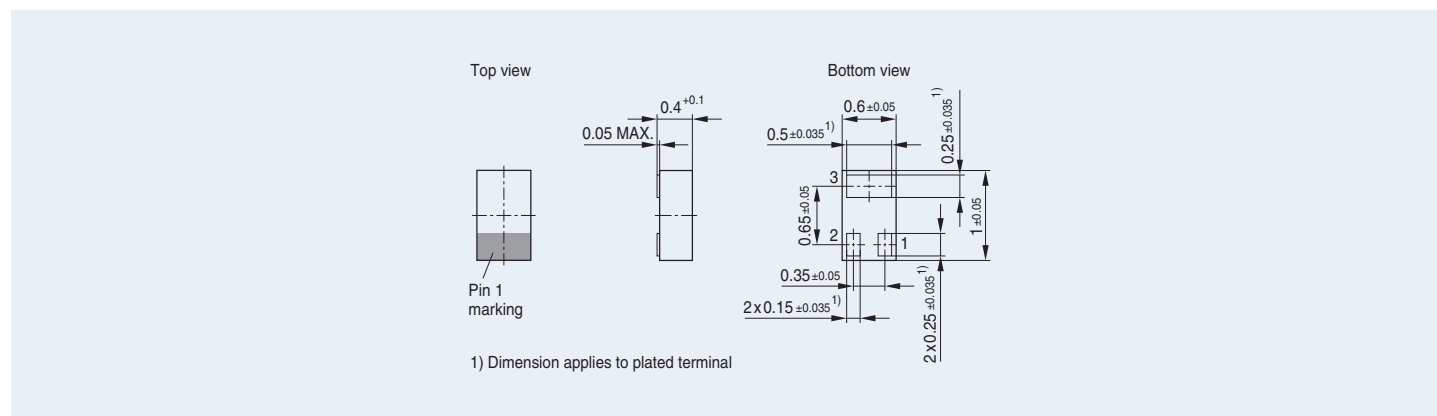

Foot Print

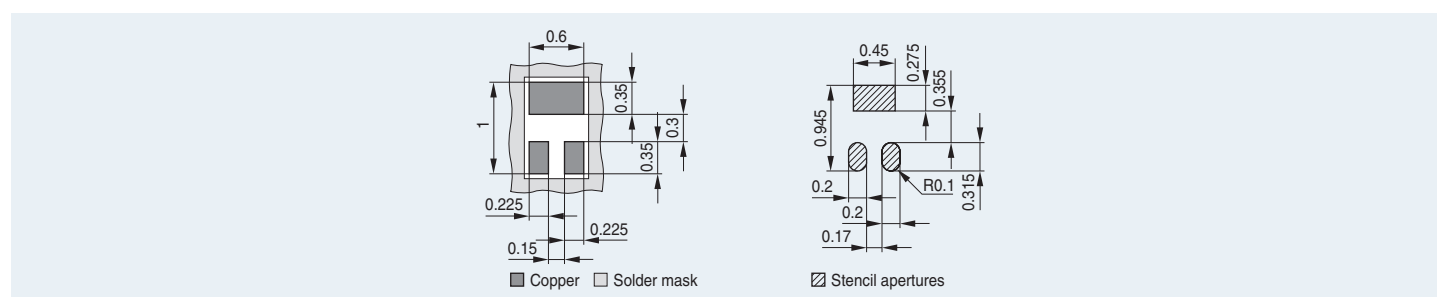

TSLP-3-7

Package Outline

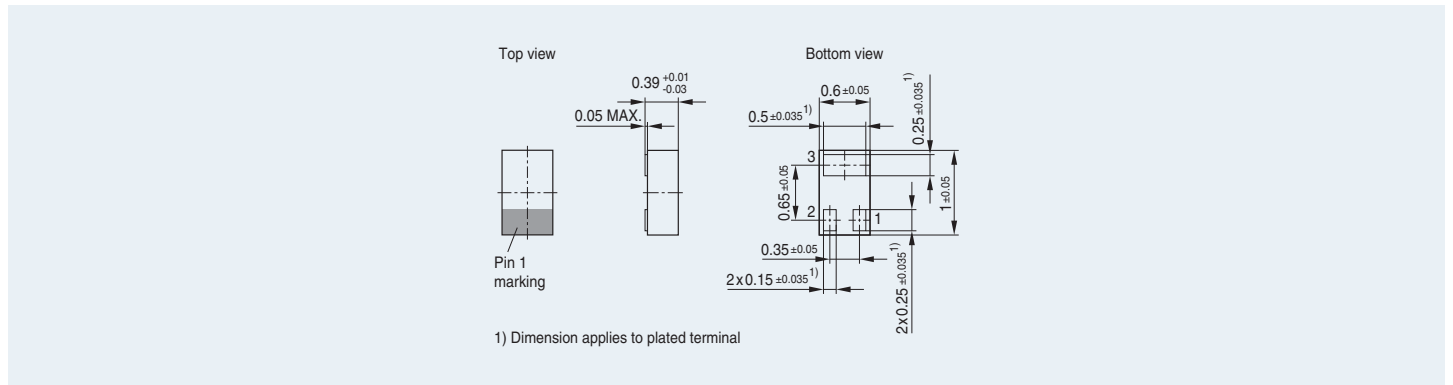

Foot Print

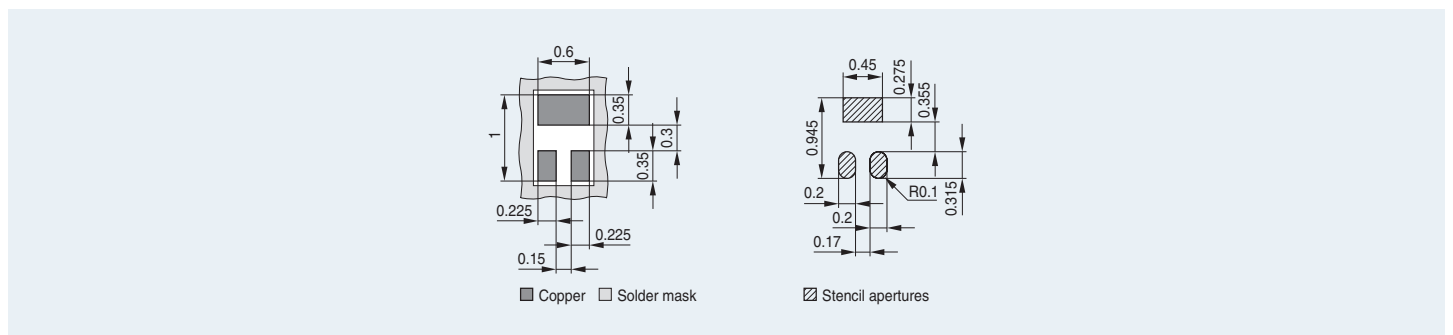

TSLP-3-9

Package Outline

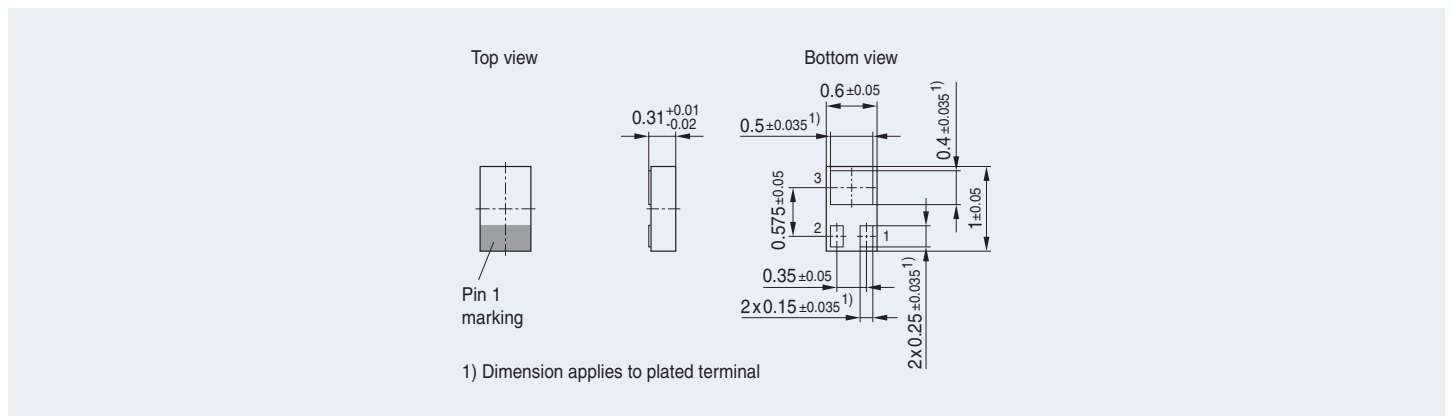

Foot Print

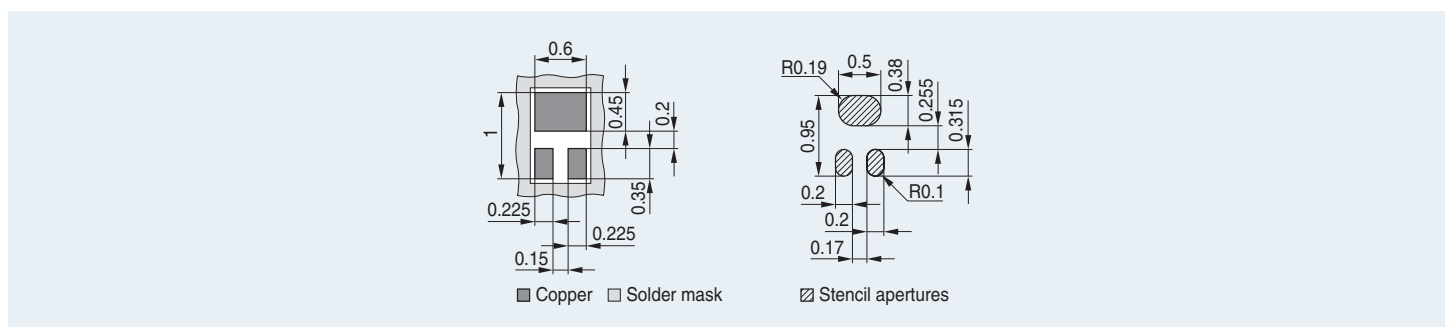

TSLP-4-7

Package Outline

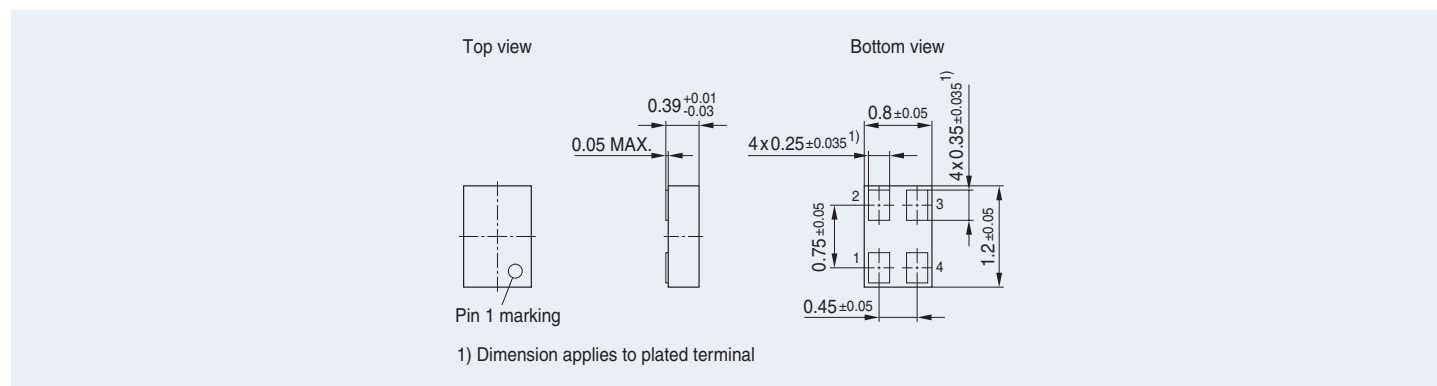

Foot Print

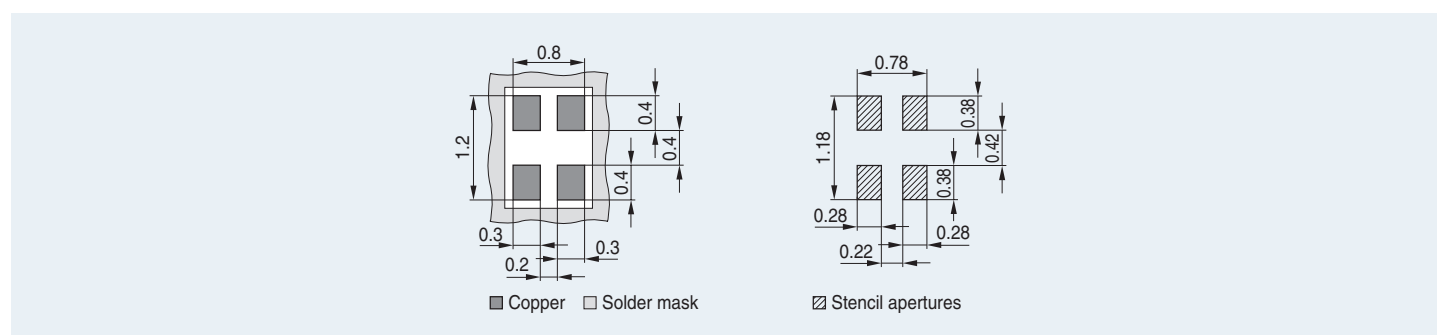

TSLP-4-10

Package Outline

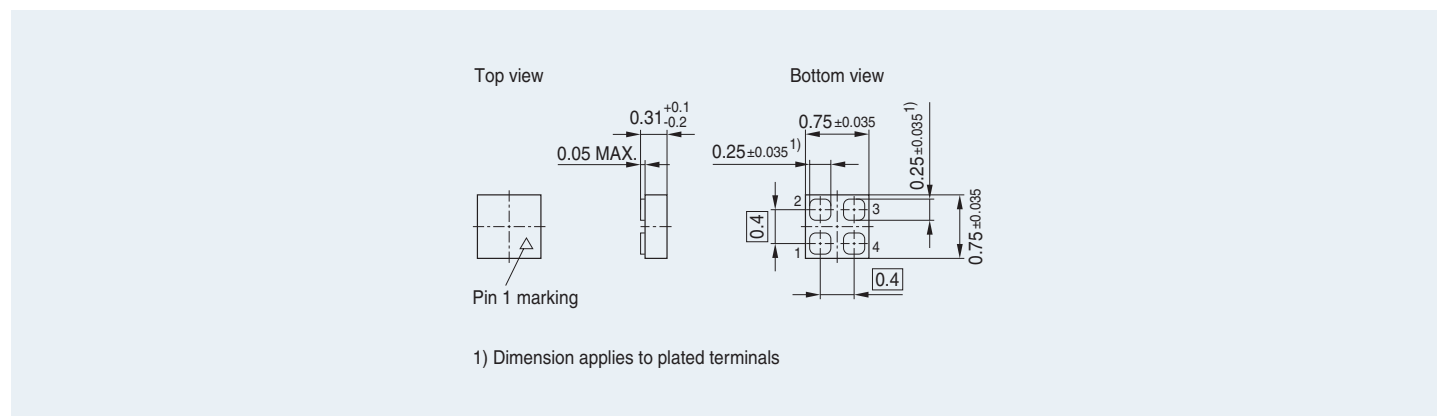

Foot Print

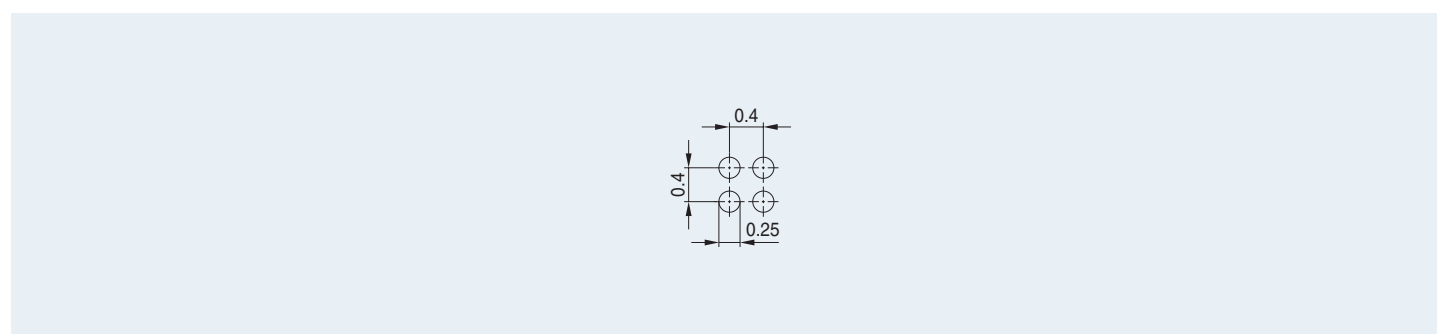

TSLP-5-2

Package Outline

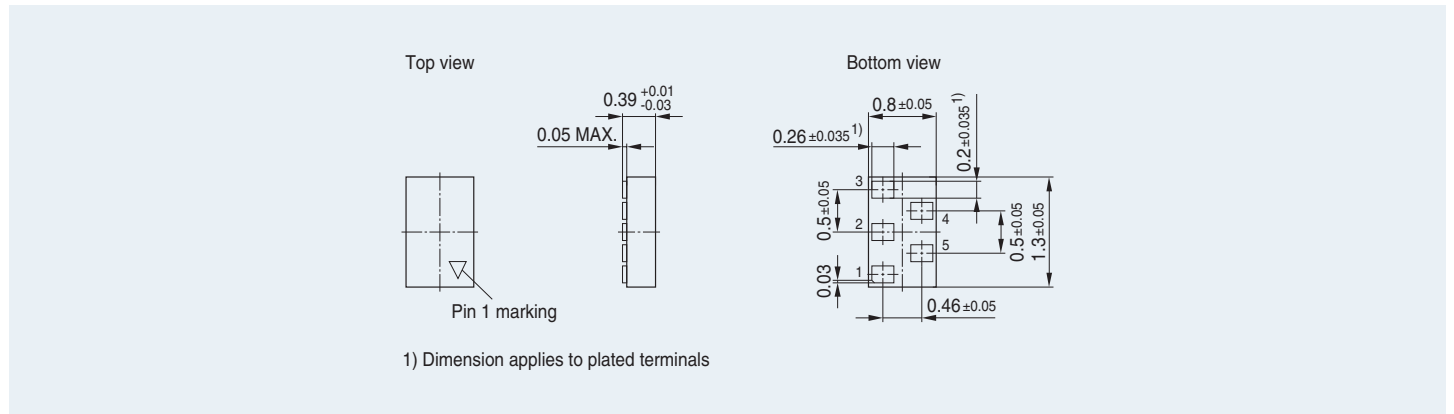

Foot Print

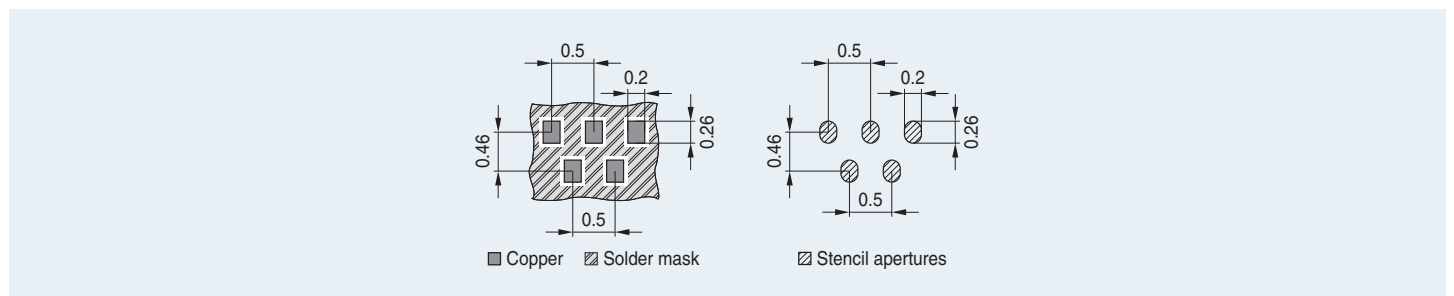

TSLP-6-2

Package Outline

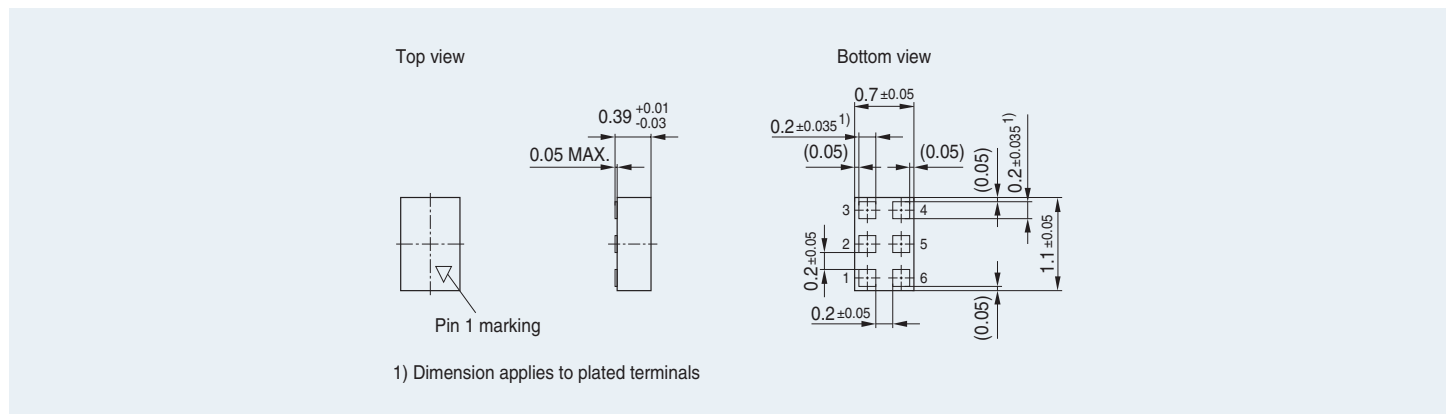

Foot Print

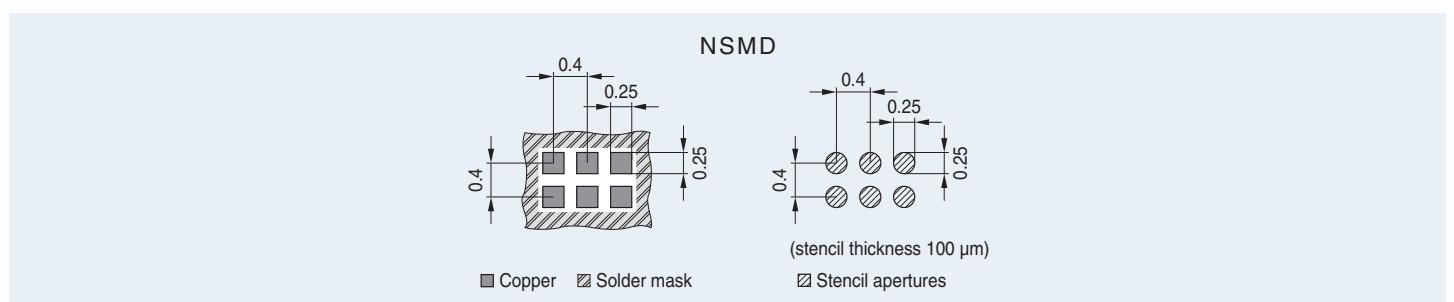

TSLP-6-3

Package Outline

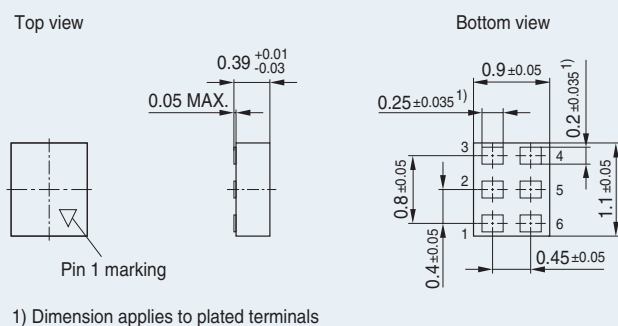

Foot Print

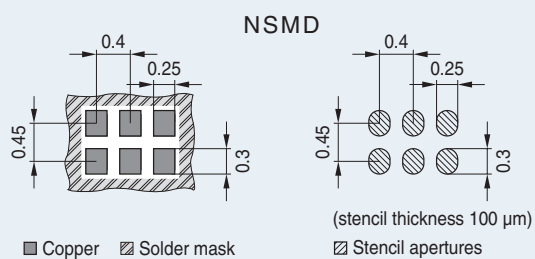

TSLP-6-4

Package Outline

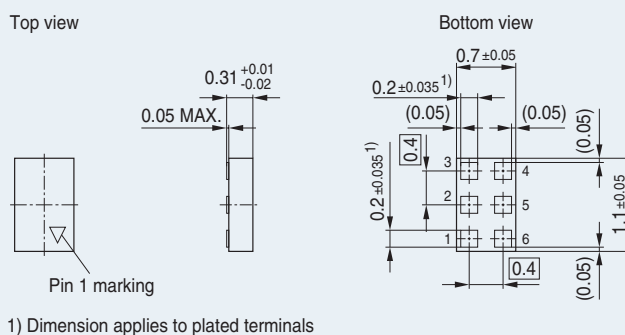

Foot Print

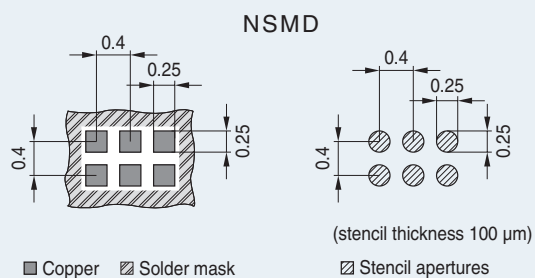

TSLP-7-1

Package Outline

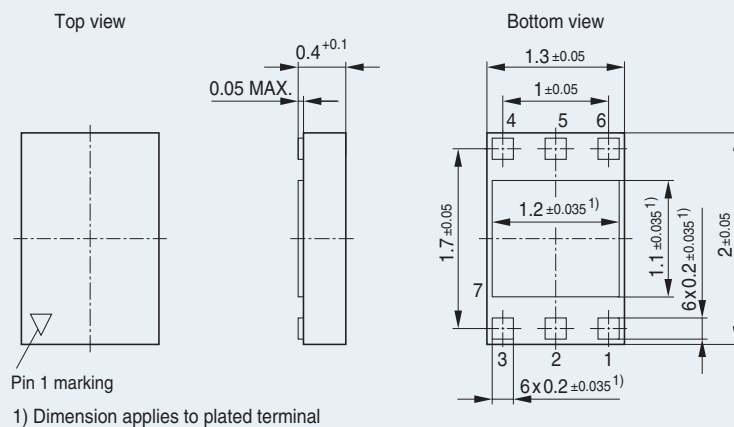

Foot Print

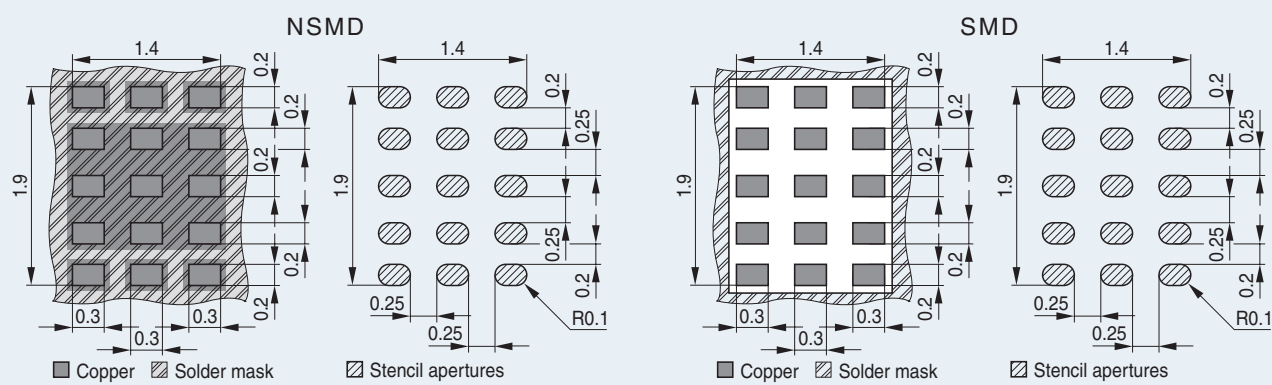

TSLP-7-6

Package Outline

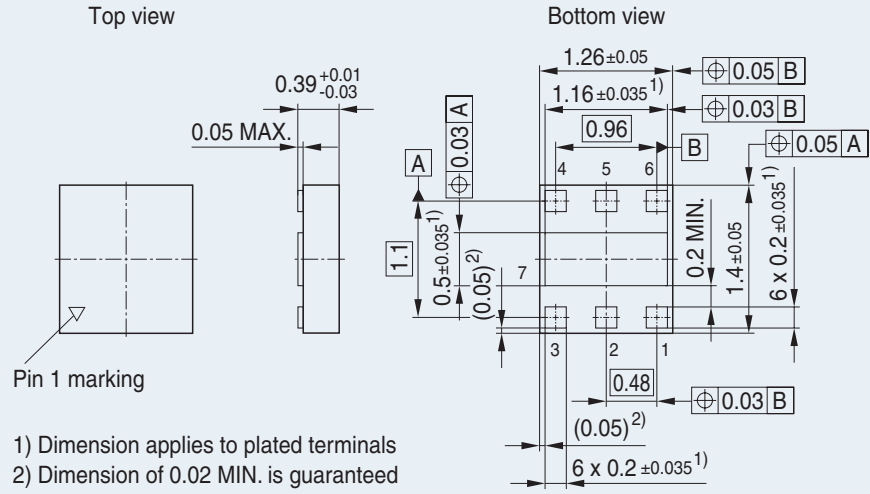

Foot Print

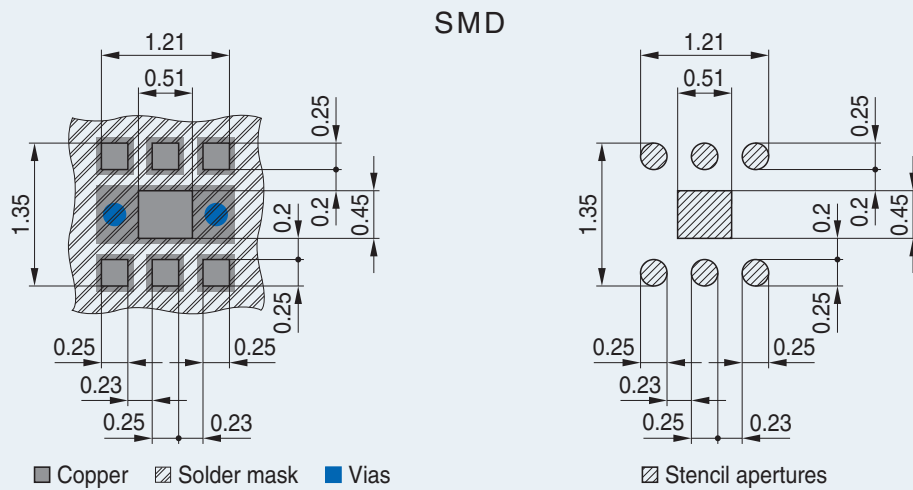

TSLP-9-3

Package Outline

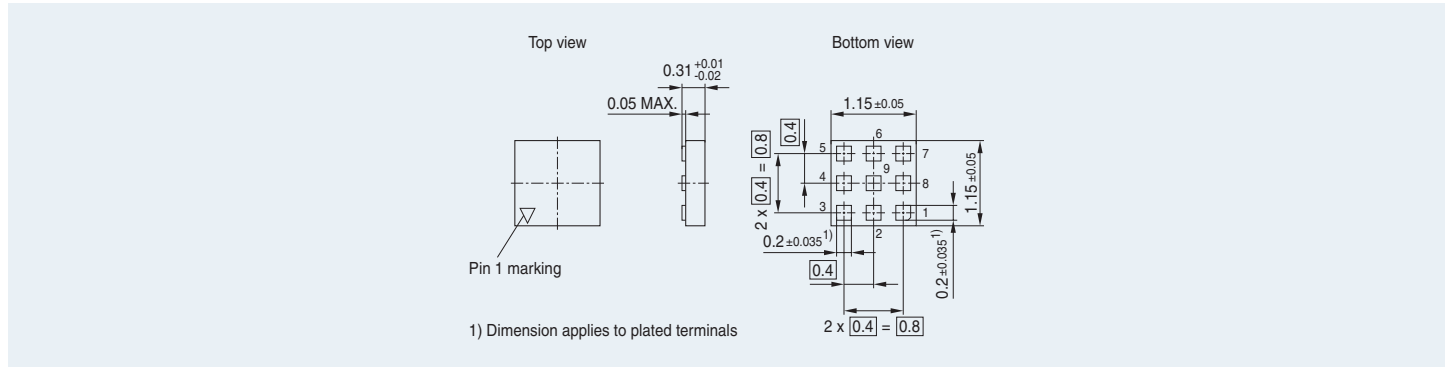

Foot Print

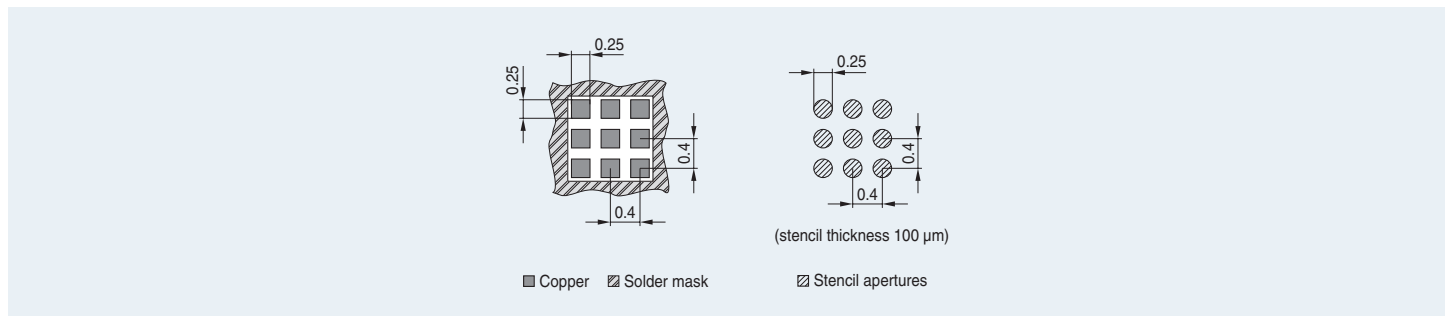

TSLP-10-1

Package Outline

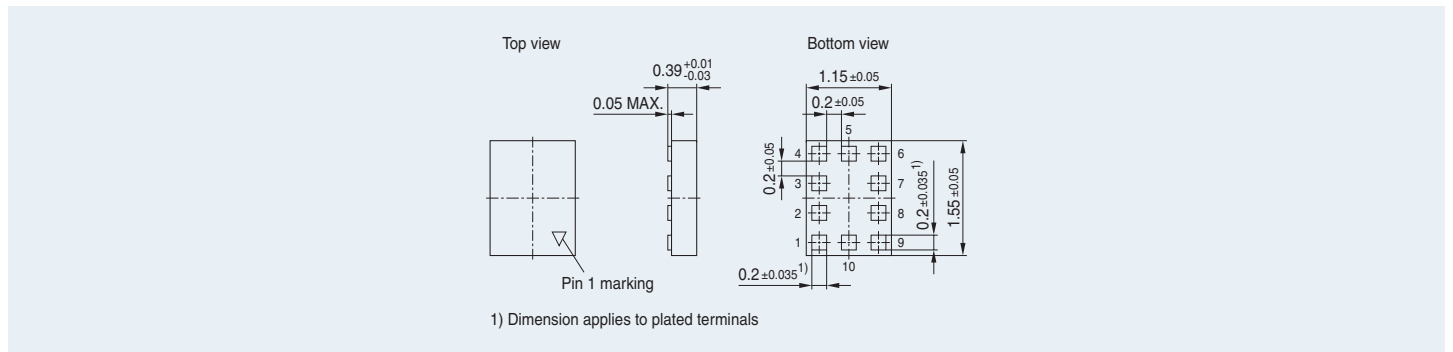

Foot Print

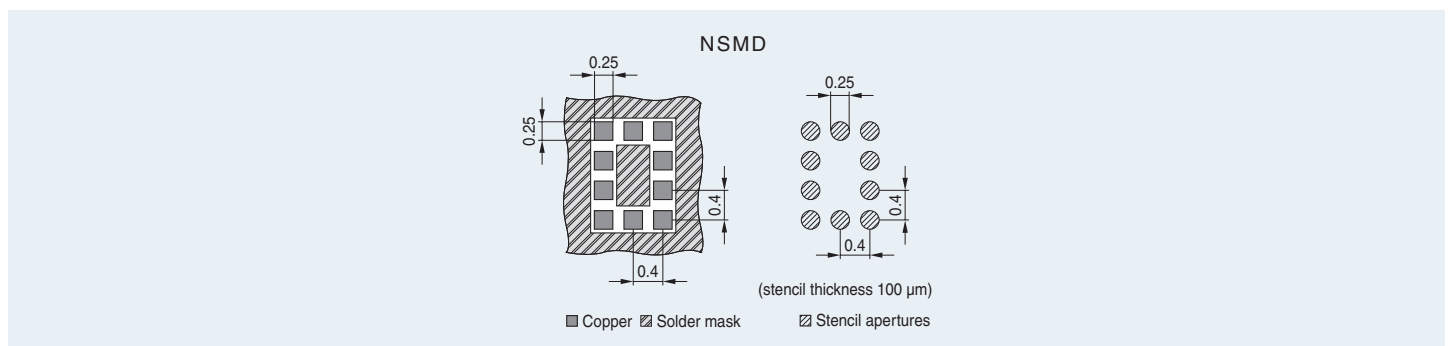

TSNP-7-10

Package Outline

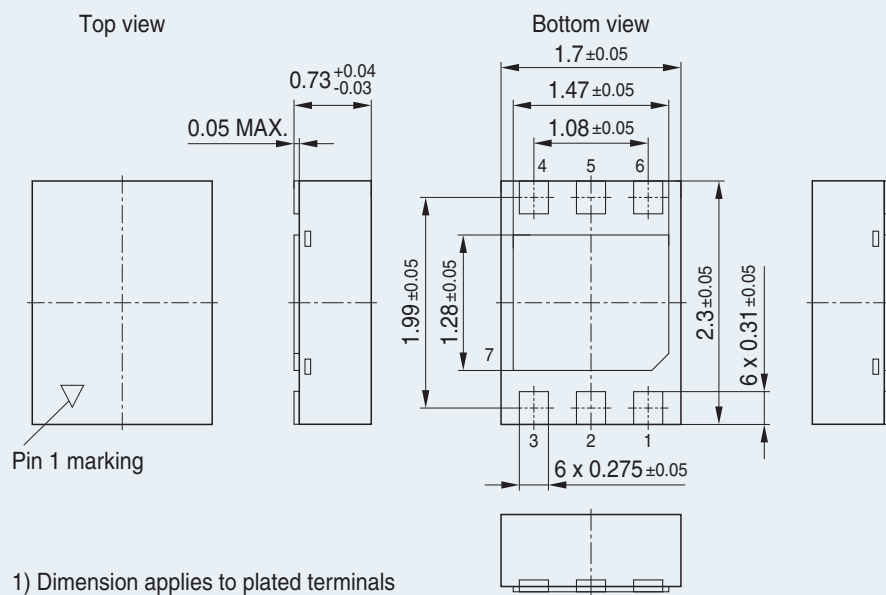

Foot Print

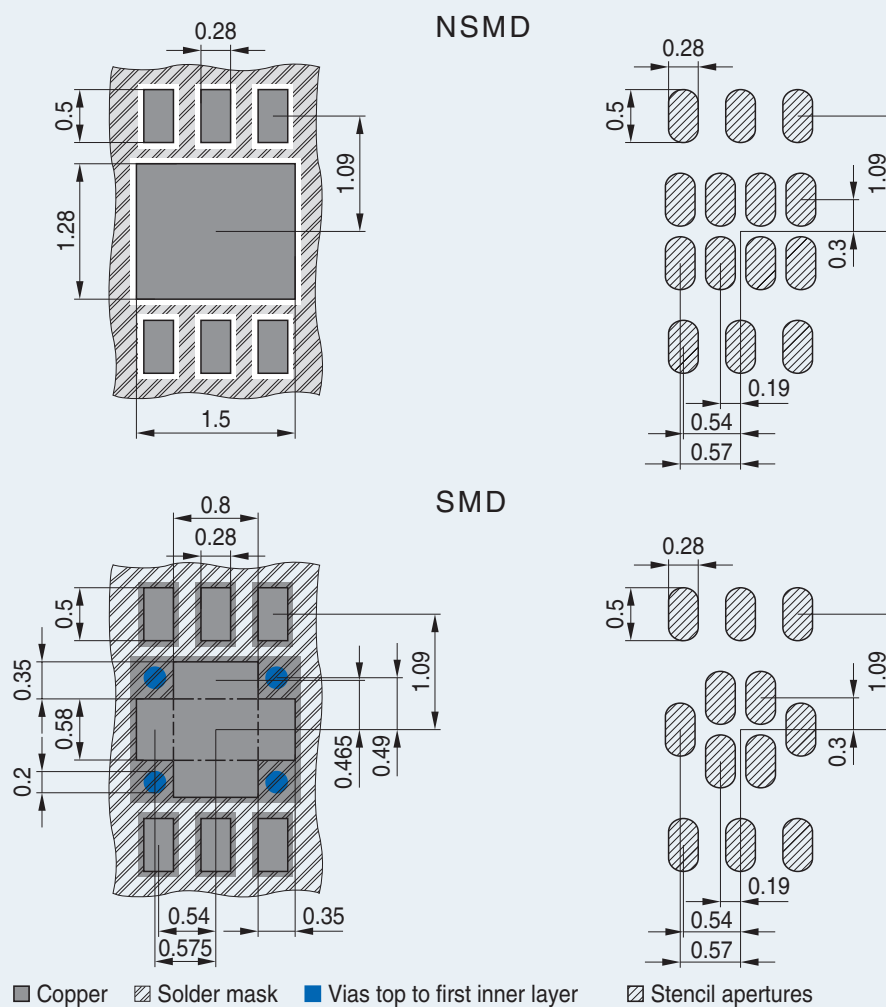

TSNP-14-3

Package Outline

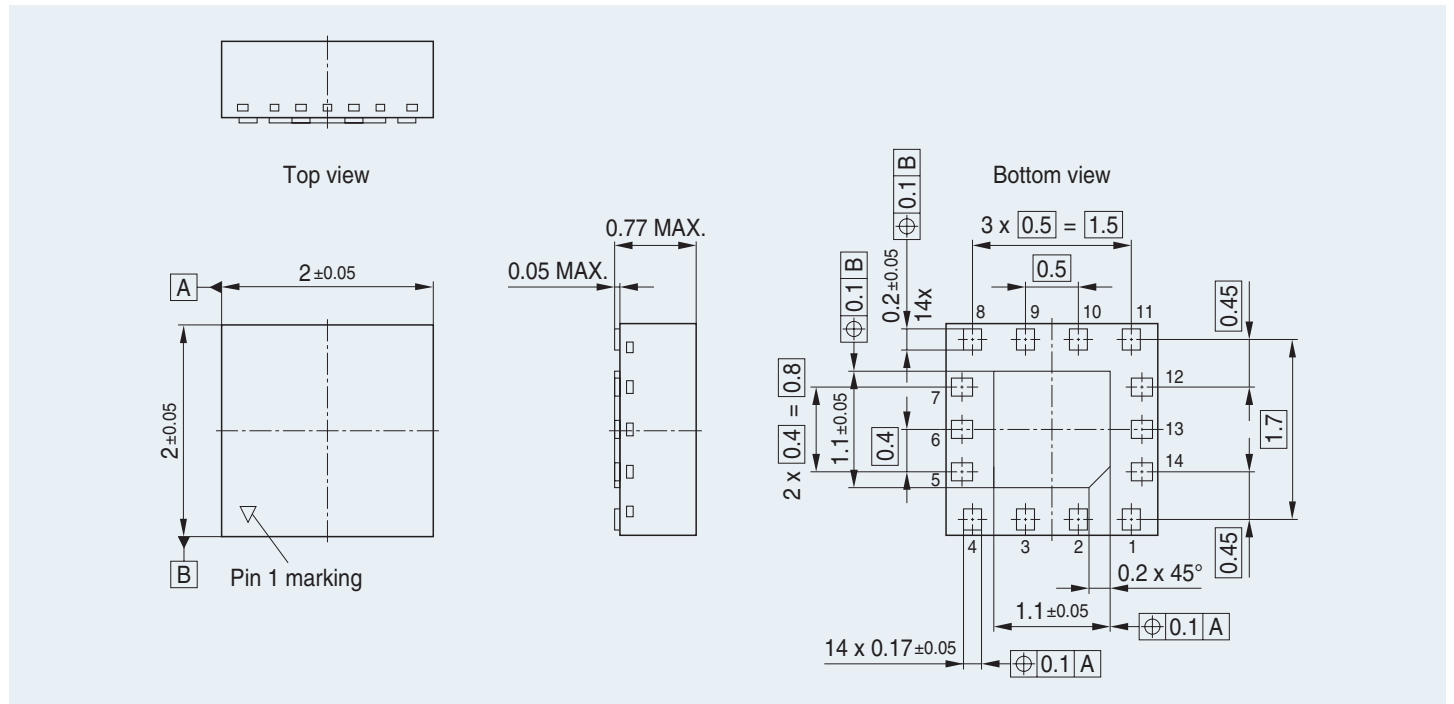

Foot Print

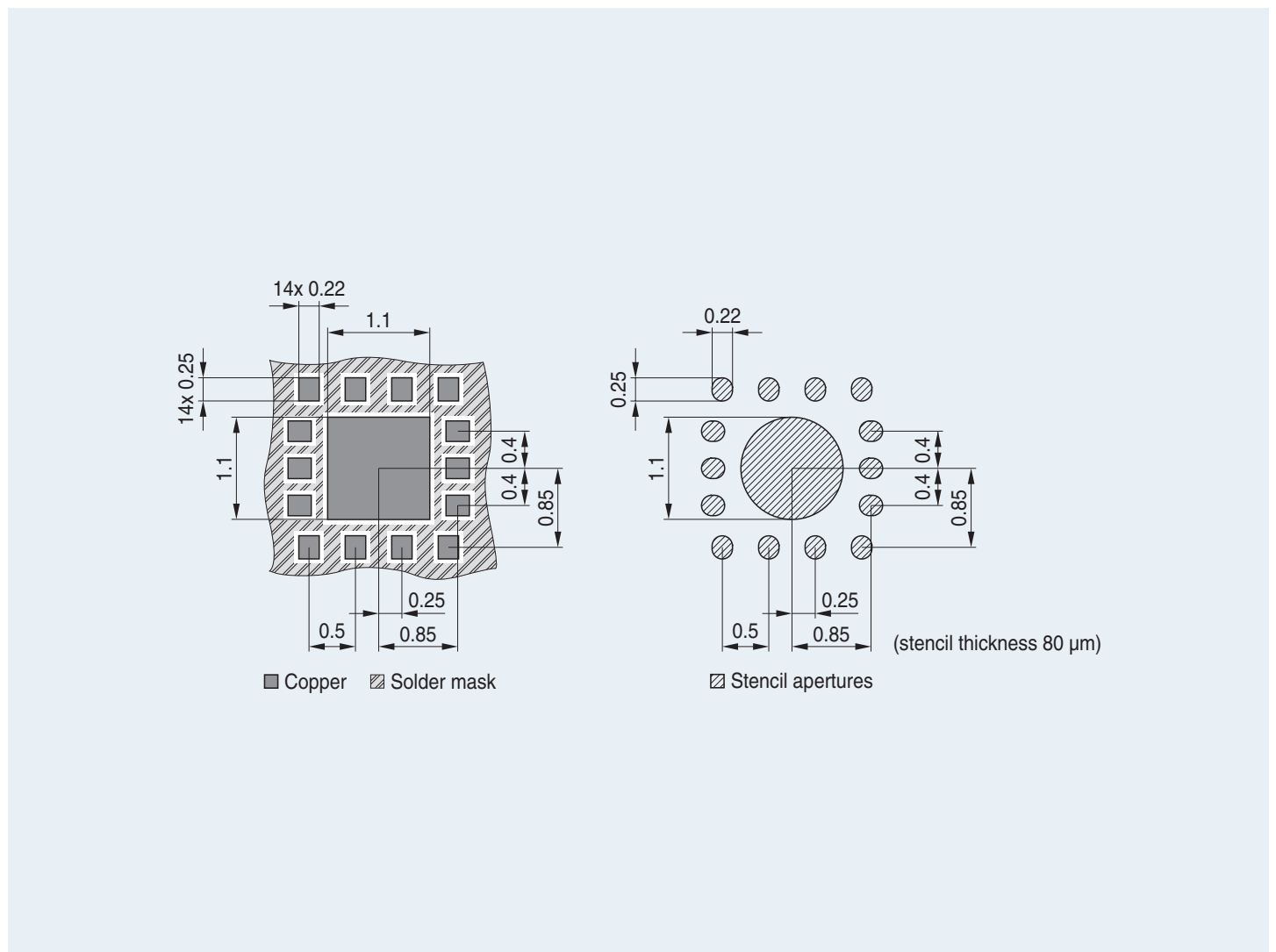

TSNP-16-6

Package Outline

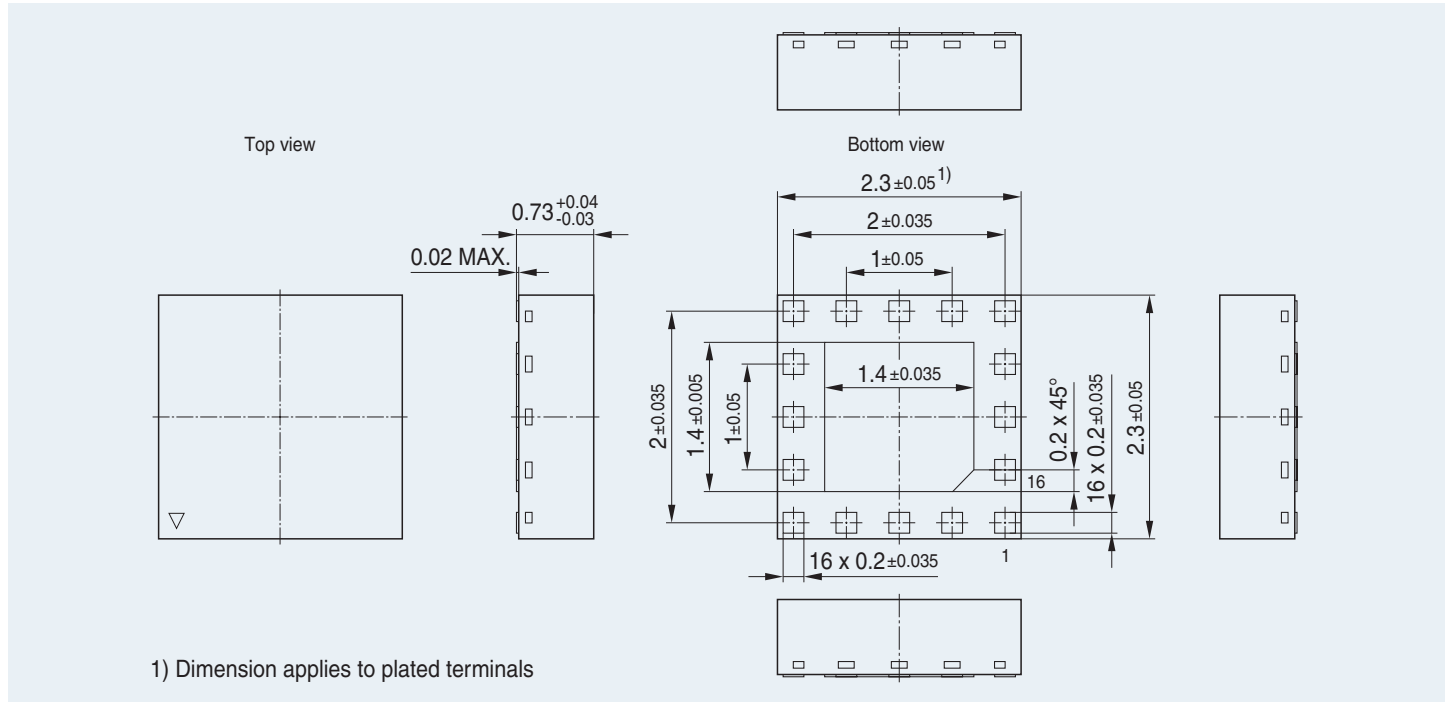

Foot Print

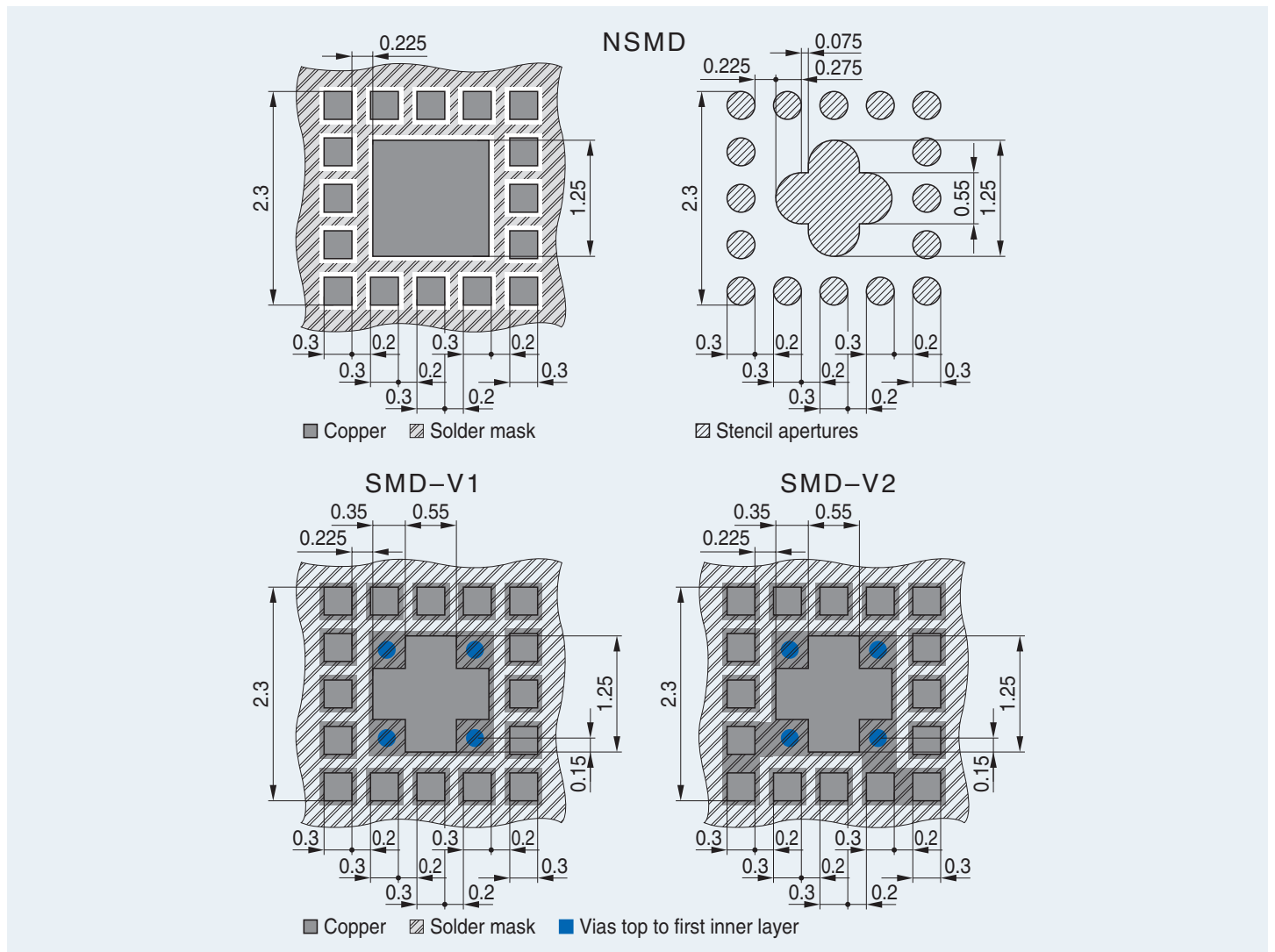

TSNP-26-2

Package Outline

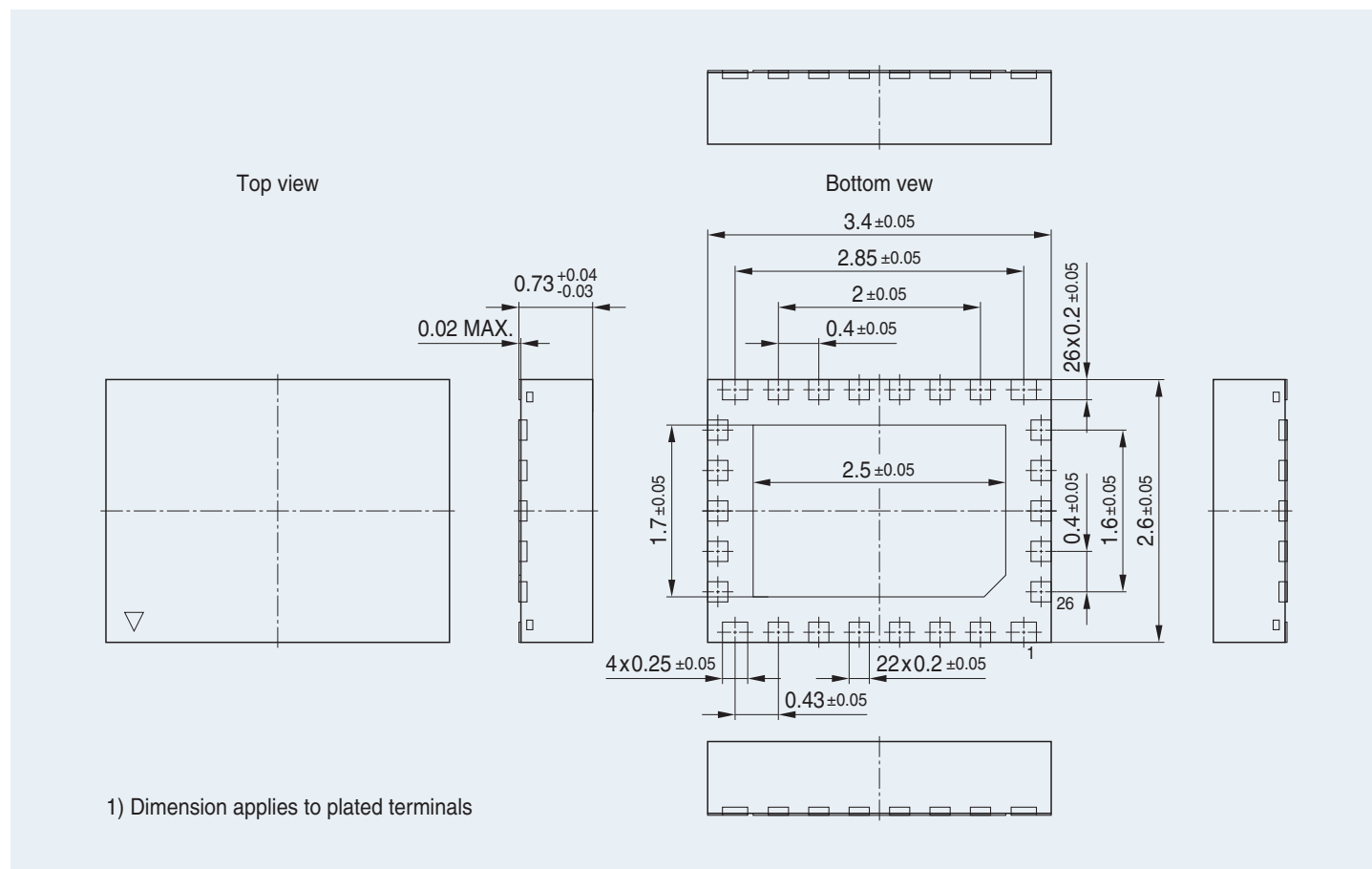

Foot Print

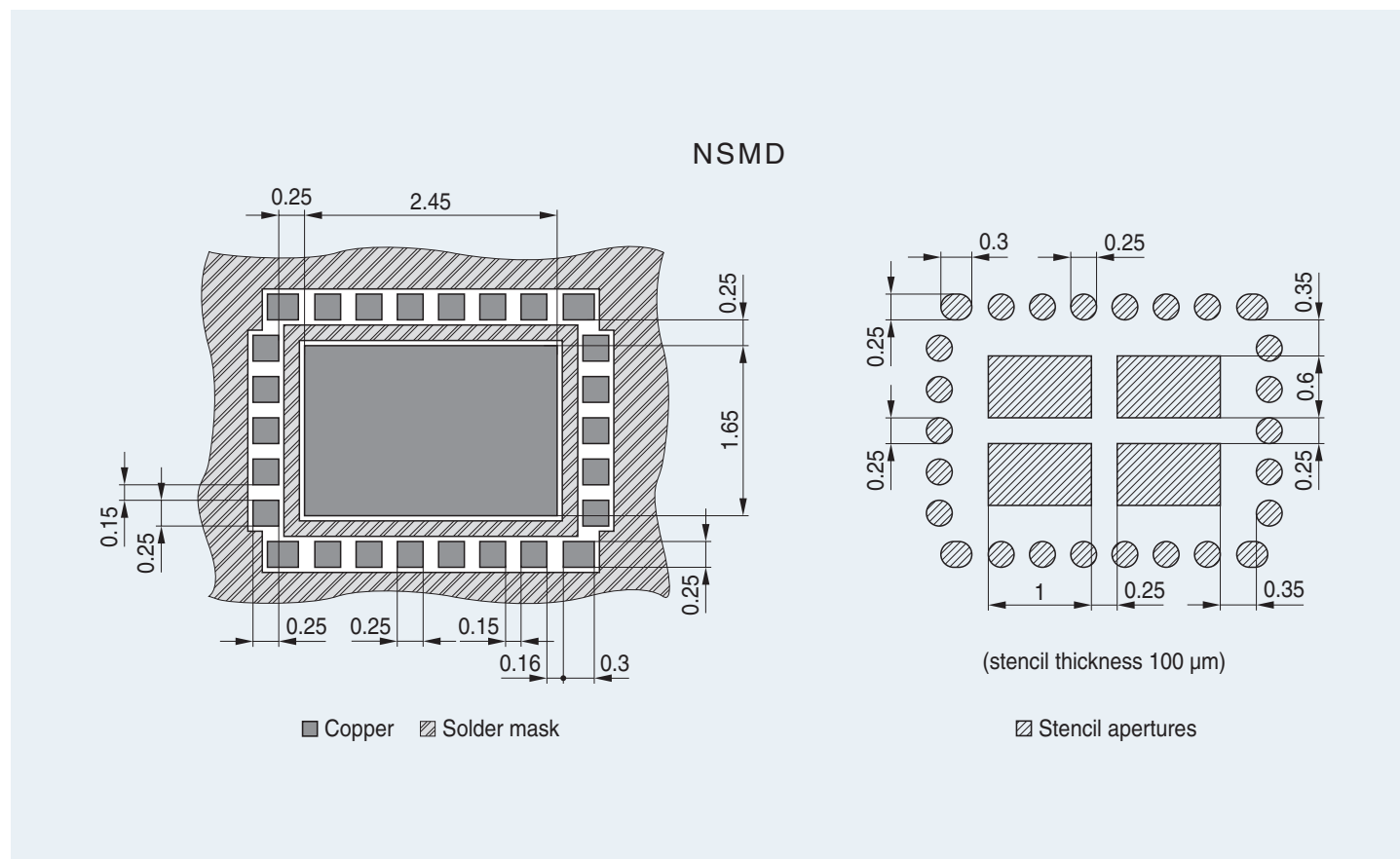

TSNP-26-3

Package Outline

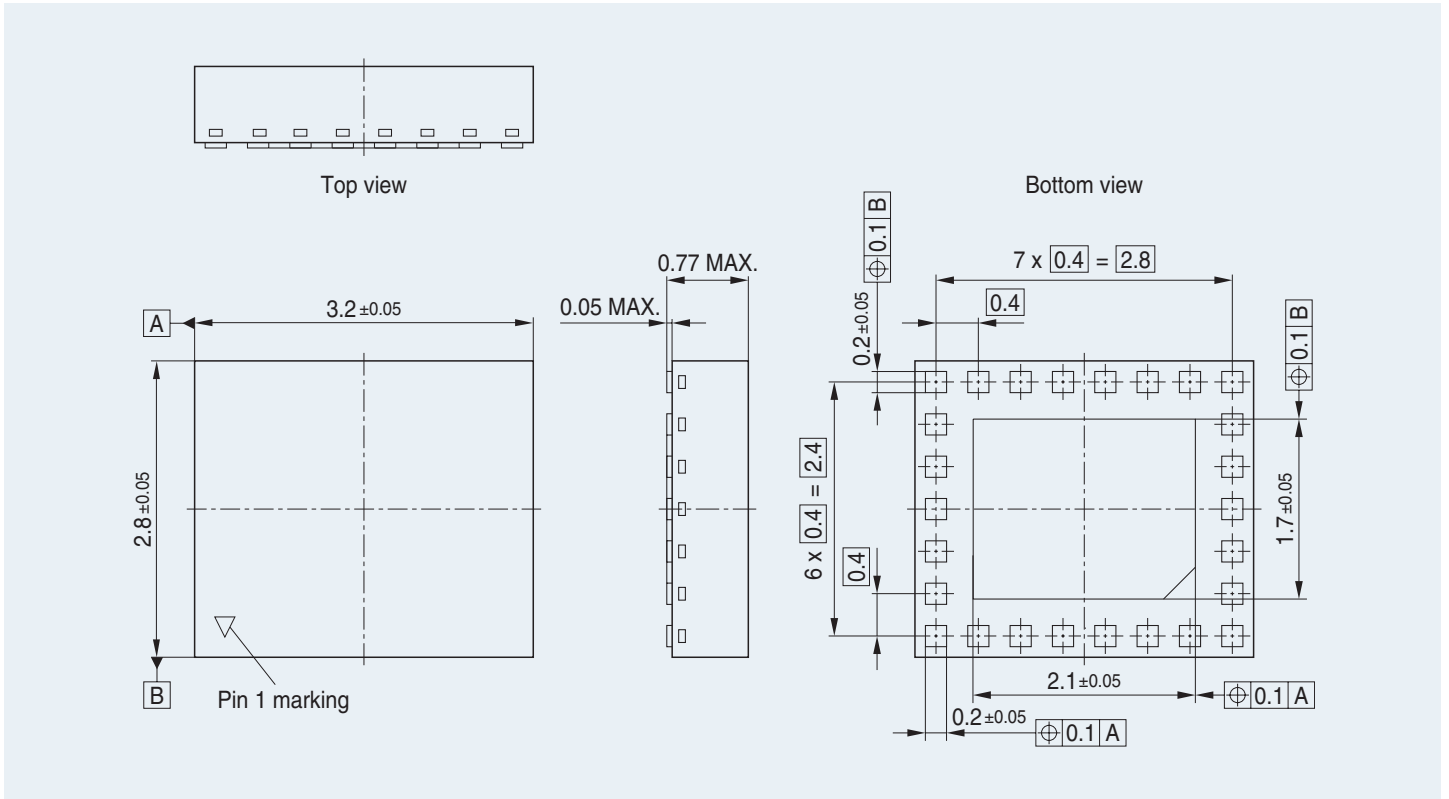

Foot Print

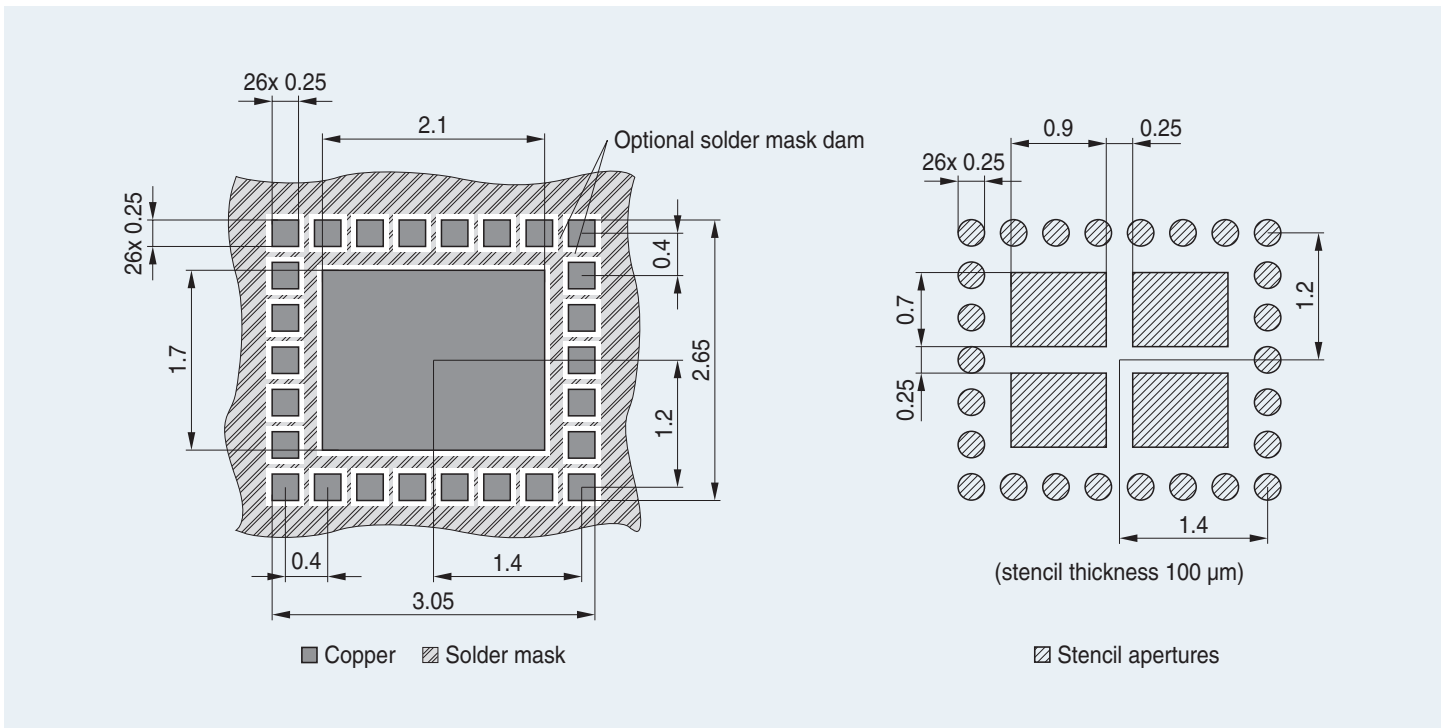

TSSLP-2-1, -2

Package Outline

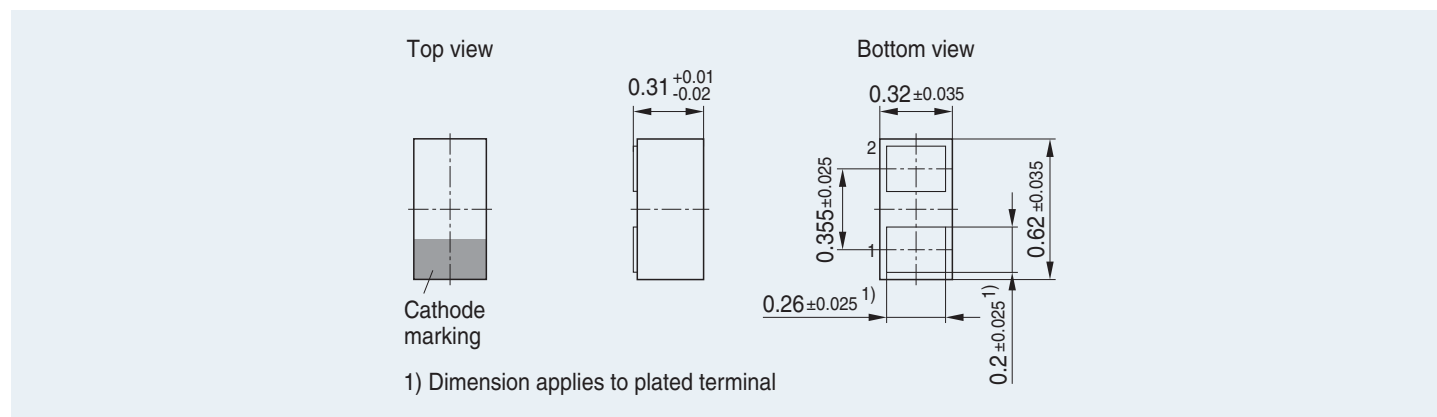

Foot Print

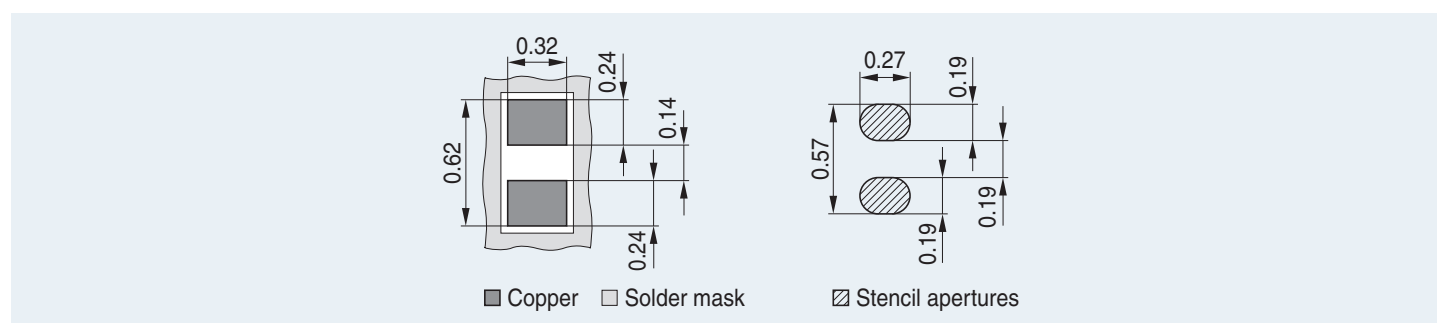

TSSLP-2-3, -4

Package Outline

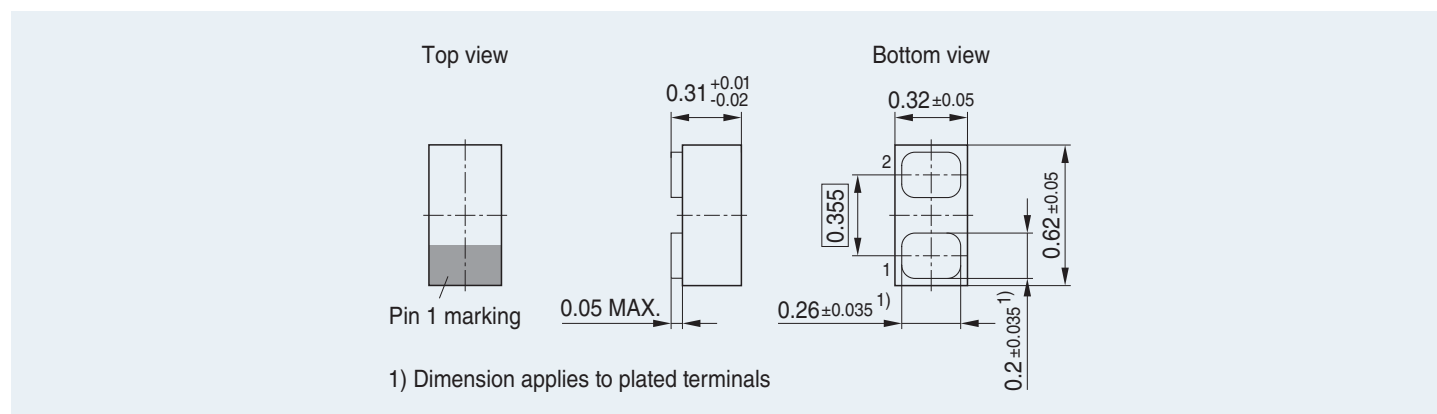

Foot Print

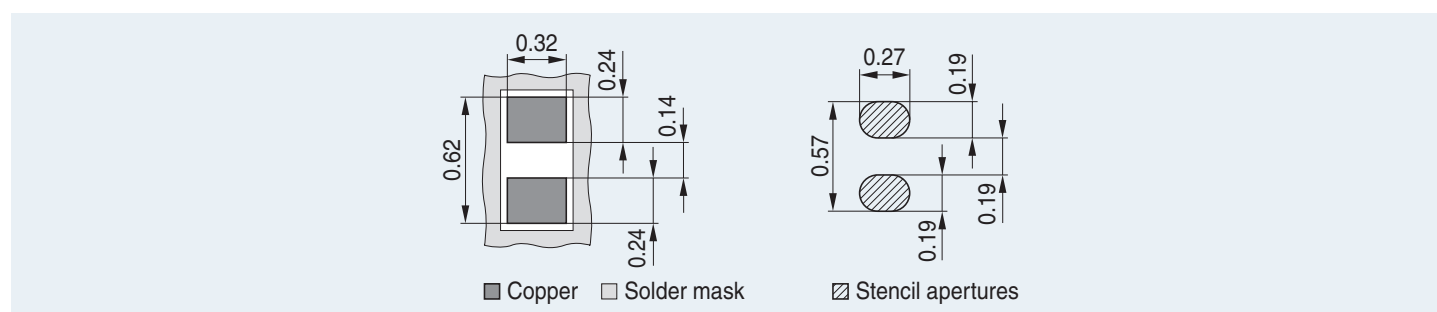

WFWLB-119-1

Package Outline

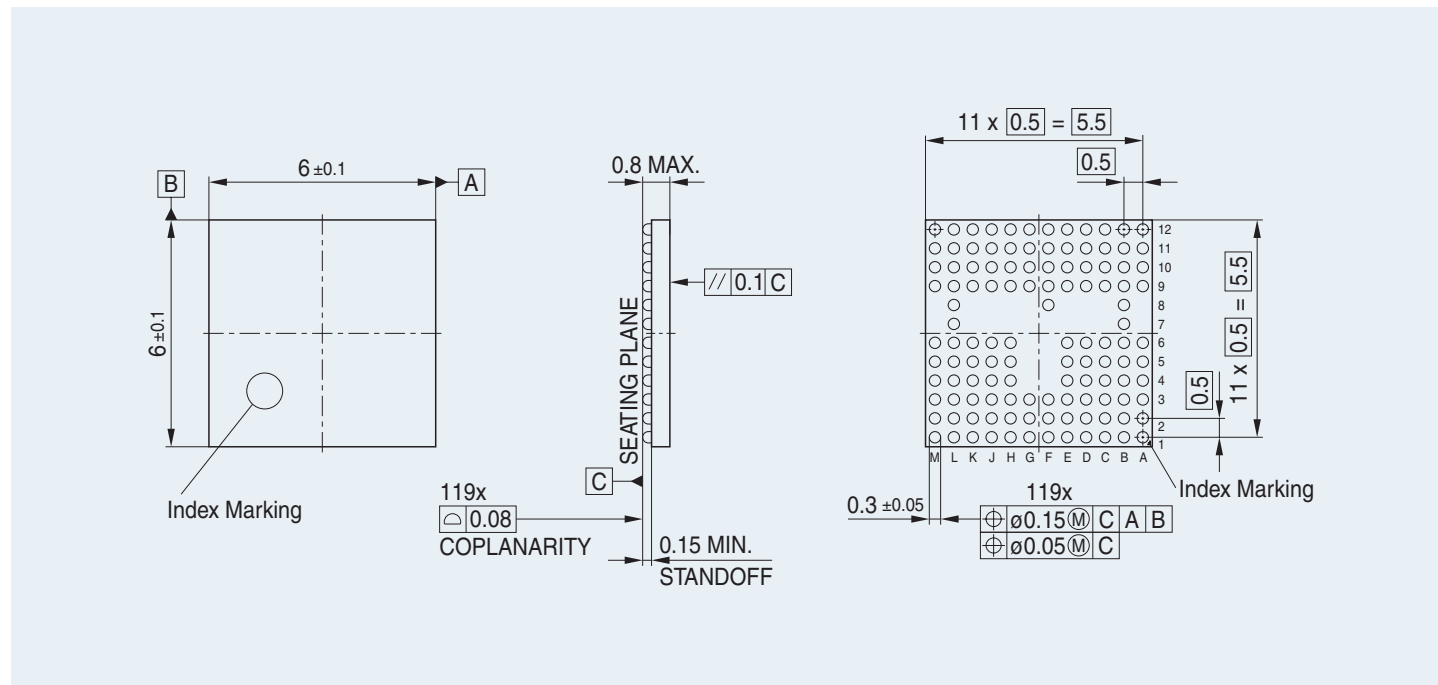

Foot Print

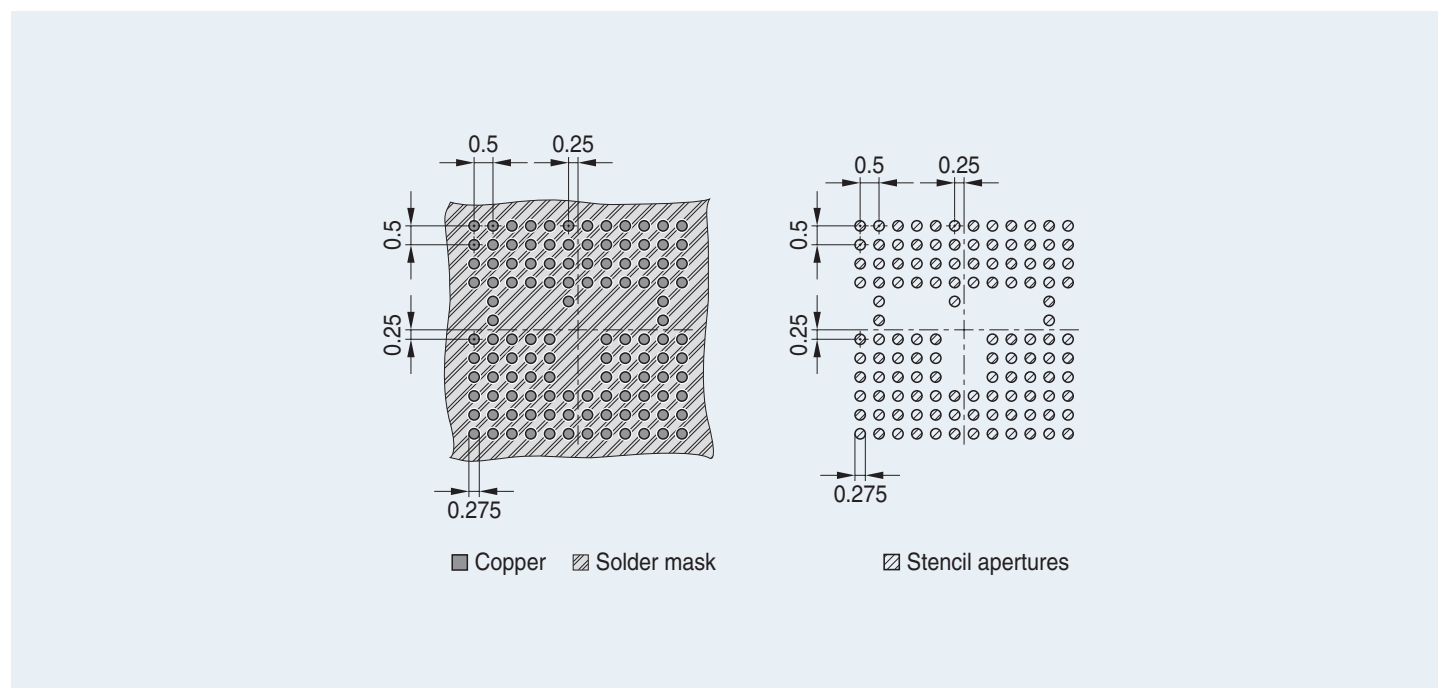

WLL-2-1

Package Outline

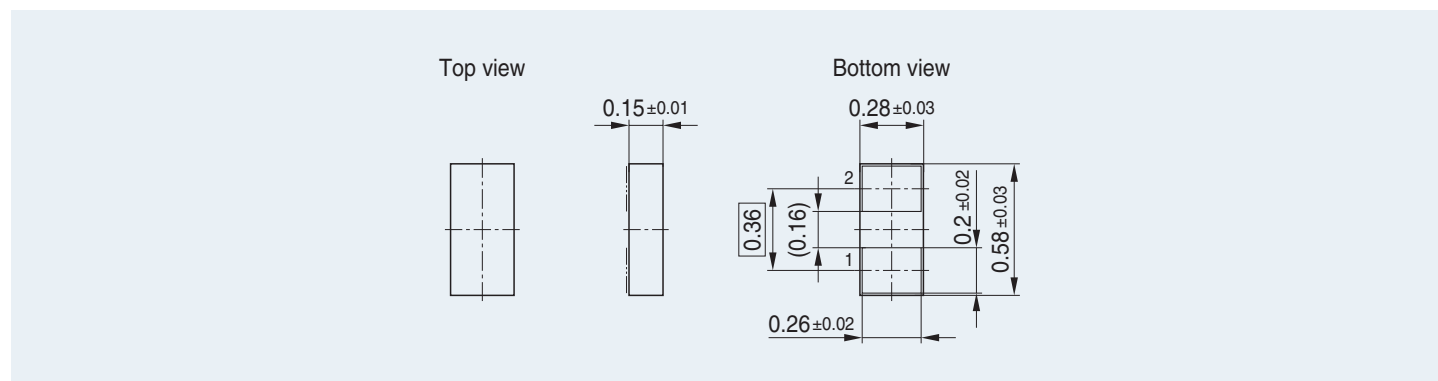

Foot Print

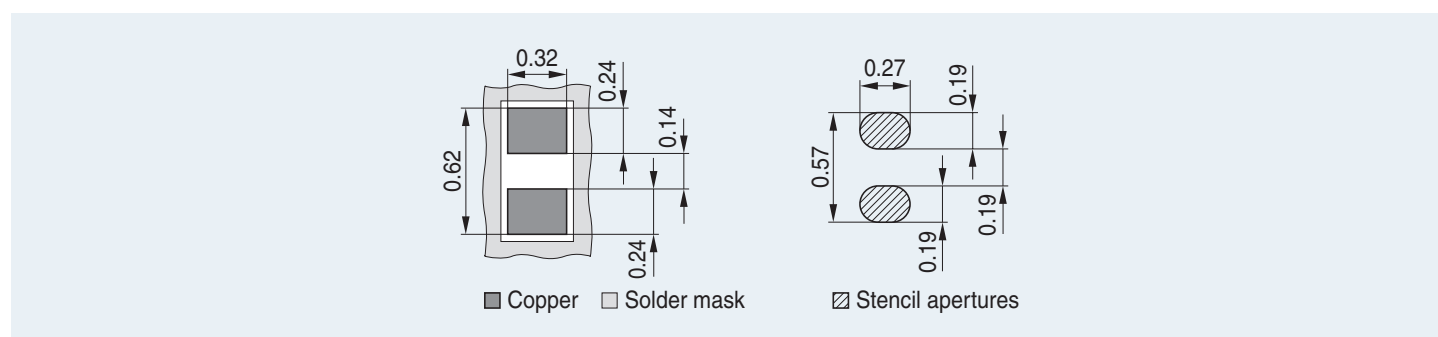

WLL-2-2

Package Outline

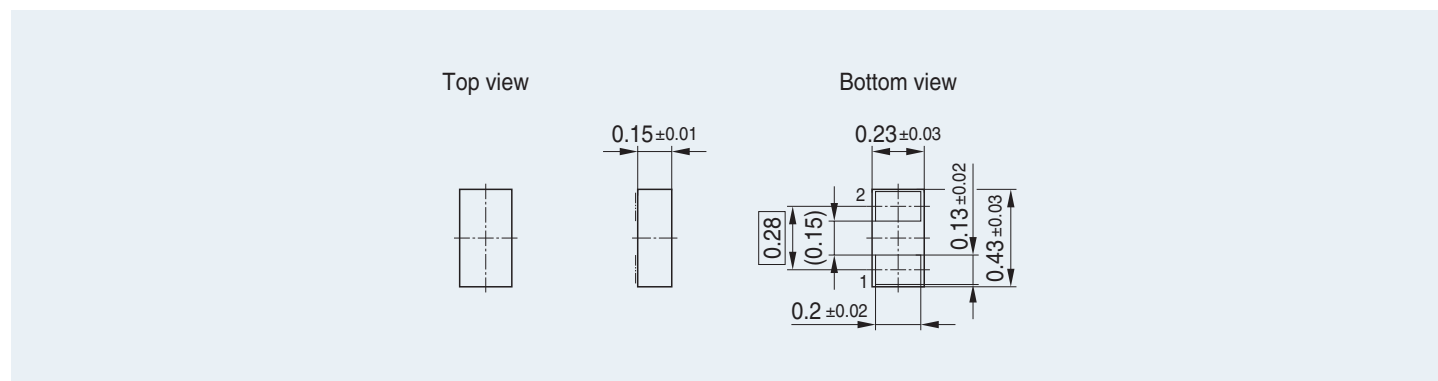

Foot Print

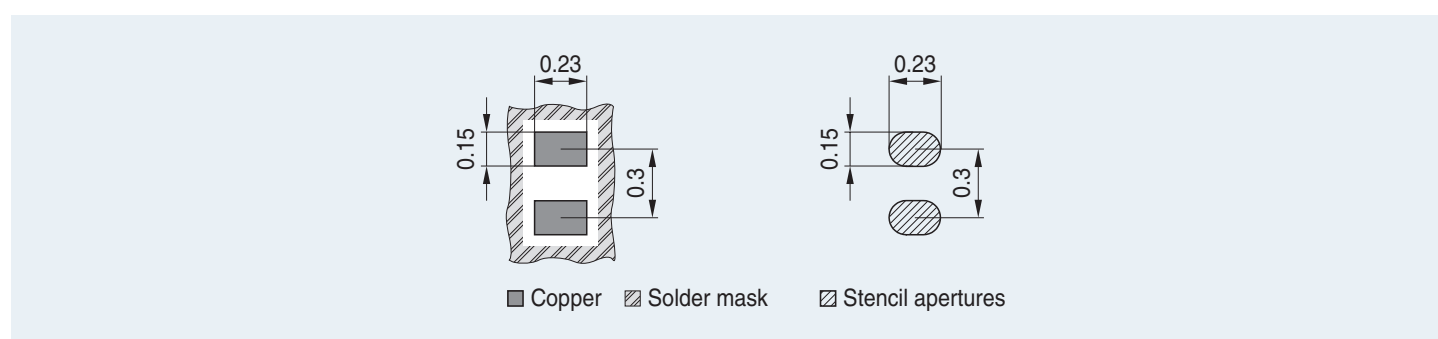

Packing Information (Tape and Reel)

Tape and Reel

(DIN IEC 286-3)

Please consult your nearest Infineon sales offices (see list of addresses) if you have any queries relating to additional dimensions, dimensional tolerances or variations.

Tape and Reel made of Plastic

ø Reel 180mm and 330mm

Carrier tape width: 8, 12mm

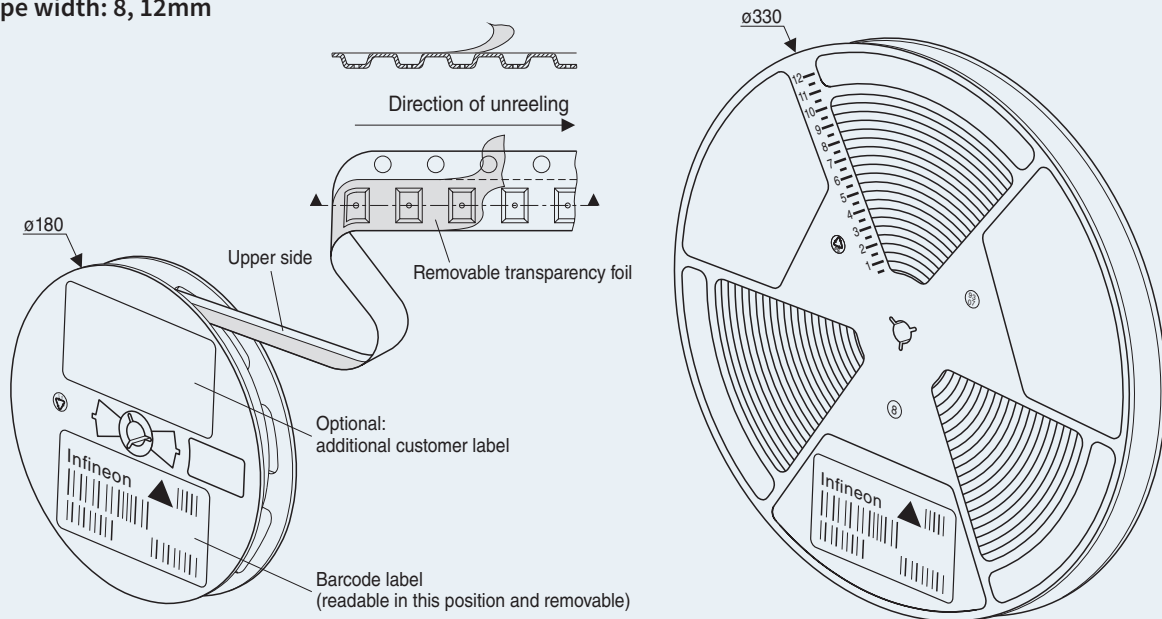

Tape and Reel made of Paper (only for TSLP Packages)

ø Reel 180mm

Carrier tape width: 8mm

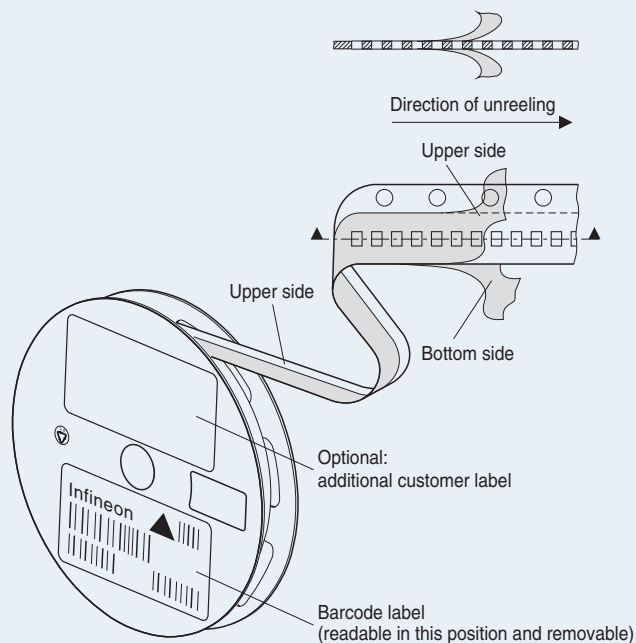

Packing Information (Tape and Reel)

Fixing on the Tape

Carrier tape width: $\leq 12\text{mm}$

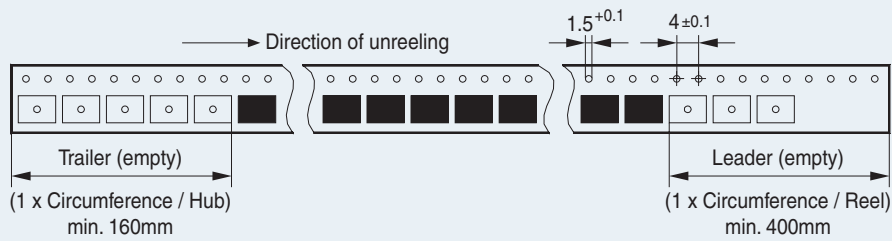
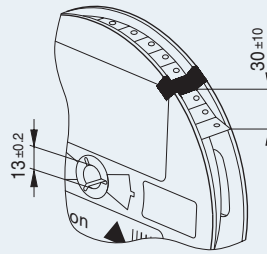

There shall be a leader of 400mm minimum of cover tape, which includes at least 100mm of carrier tape with empty compartments. All the leader may consist of the carrier tape with empty compartments, sealed by cover tape.

For 1 Tape (resembling a pizza box)

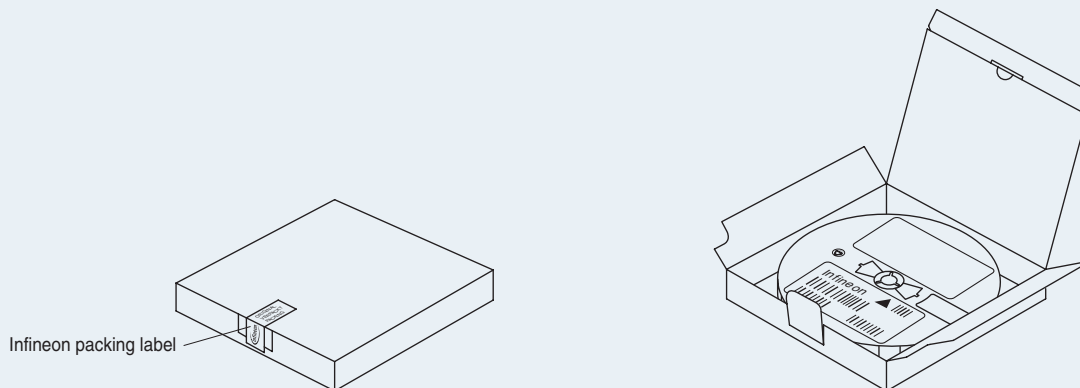

Up to 10 Tapes

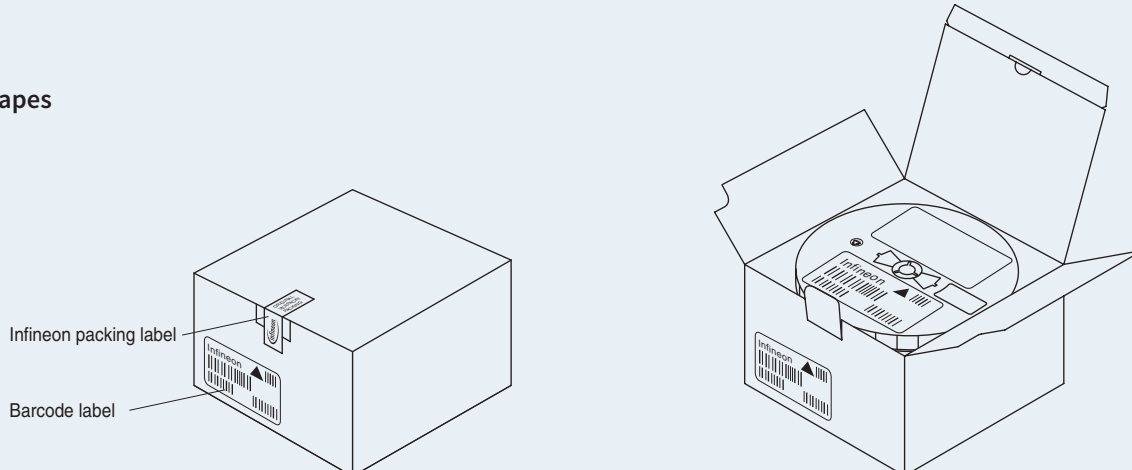

Support Material

More detailed Information on RF & Protection Devices

Data Sheets/Application Notes/Technical Reports

www.infineon.com/esdprotection
www.infineon.com/rf

Please see also the product pages of this brochure for direct links.

Brochures:

- Application Guide for Mobile Communication
- Application Guide for Protection
- Application Guide for Industrial
- Application Guide for Consumer

www.infineon.com/rpd_appguide_mobile
www.infineon.com/rpd_appguide_protection
www.infineon.com/rpd_appguide_industrial
www.infineon.com/rpd_appguide_consumer

Evaluation Boards

For more information please contact your sales counterpart.

Visit our ESD Protection Forum: www.infineon.com/esdforum

Ask Infineon. Get connected with the answers.

Infineon offers its toll-free 0800/4001 service hotline as one central number, available 24/7 in English, Mandarin and German.

Our global connection service goes way beyond standard switchboard services by offering qualified support on the phone. Call us!

- Germany 0800 951 951 951 (German/English)
- China, mainland 4001 200 951 (Mandarin/English)
- India 000 800 4402 951 (English)
- USA 1-866 951 9519 (English/German)
- Other countries 00* 800 951 951 951 (English/German)
- Direct access +49 89 234-0 (interconnection fee, German/English)

* Please note: Some countries may require you to dial a code other than "00" to access this international number, please visit www.infineon.com/service for your country!

Where to Buy

Infineon Distribution Partners and Sales Offices:

www.infineon.com/WhereToBuy

Stay connected

 www.facebook.com/infineon

 www.google.com/+infineon

 www.twitter.com/infineon

 www.infineon.com/linkedin

 www.infineon.com/xing

 www.youtube.com/infineon

Mobile Product Catalog

Mobile app for iOS and Android.



Published by
Infineon Technologies AG
85579 Neubiberg, Germany

© 2014 Infineon Technologies AG.
All Rights Reserved.

Visit us:
www.infineon.com

Order Number: B132-I0011-V1-7600-EU-EC-P
Date: 09/2014

Attention please!

The information given in this document shall in no event be regarded as a guarantee of conditions or characteristics ("Beschaffheitsgarantie"). With respect to any examples or hints given herein, any typical values stated herein and/or any information regarding the application of the device, Infineon Technologies hereby disclaims any and all warranties and liabilities of any kind, including without limitation warranties of non-infringement of intellectual property rights of any third party.

Information

For further information on technology, delivery terms and conditions and prices please contact your nearest Infineon Technologies Office (www.infineon.com).

Warnings

Due to technical requirements components may contain dangerous substances. For information on the types in question please contact your nearest Infineon Technologies Office. Infineon Technologies Components may only be used in life-support devices or systems with the express written approval of Infineon Technologies, if a failure of such components can reasonably be expected to cause the failure of that life-support device or system, or to affect the safety or effectiveness of that device or system. Life support devices or systems are intended to be implanted in the human body, or to support and/or maintain and sustain and/or protect human life. If they fail, it is reasonable to assume that the health of the user or other persons may be endangered.

Данный компонент на территории Российской Федерации

Вы можете приобрести в компании MosChip.

Для оперативного оформления запроса Вам необходимо перейти по данной ссылке:

<http://moschip.ru/get-element>

Вы можете разместить у нас заказ для любого Вашего проекта, будь то серийное производство или разработка единичного прибора.

В нашем ассортименте представлены ведущие мировые производители активных и пассивных электронных компонентов.

Нашей специализацией является поставка электронной компонентной базы двойного назначения, продукции таких производителей как XILINX, Intel (ex.ALTERA), Vicor, Microchip, Texas Instruments, Analog Devices, Mini-Circuits, Amphenol, Glenair.

Сотрудничество с глобальными дистрибьюторами электронных компонентов, предоставляет возможность заказывать и получать с международных складов практически любой перечень компонентов в оптимальные для Вас сроки.

На всех этапах разработки и производства наши партнеры могут получить квалифицированную поддержку опытных инженеров.

Система менеджмента качества компании отвечает требованиям в соответствии с ГОСТ Р ИСО 9001, ГОСТ РВ 0015-002 и ЭС РД 009

Офис по работе с юридическими лицами:

105318, г.Москва, ул.Щербаковская д.3, офис 1107, 1118, ДЦ «Щербаковский»

Телефон: +7 495 668-12-70 (многоканальный)

Факс: +7 495 668-12-70 (доб.304)

E-mail: info@moschip.ru

Skype отдела продаж:

moschip.ru

moschip.ru_4

moschip.ru_6

moschip.ru_9