

Classification	SPECIFICATION	Issue No. 20150092
Part Name 4.5mm x 2.2mm Side-operational Edge-mount Light Touch Switch	Part No. EVPAEGE2A	1 / 8
<p>1. Notification Items</p> <p>1.1 Law and the regulation which are applied</p> <ul style="list-style-type: none"> ① Ozone depleting substances specified by Montreal Protocol have not been used in the manufacturing process of the material used in this product. ② This product complies with RoHS Directive (on the restriction of the use of certain hazardous substances in electrical and electronic equipment) (2011/65/EU). ③ The materials used in this product contain only the substances listed in the List of Existing Chemical Substances specified in 'Act on the Evaluation of Chemical Substances and Regulation of Their Manufacture, etc'. ④ Permission must be obtained from the Japanese government if the product that is subject to the "Foreign Exchange and Foreign Trade Law" is to be exported or taken out of Japan. <p>1.2 Application Limits</p> <p>The following shall be described for safety precaution: [Limitation of Application]</p> <ul style="list-style-type: none"> - This product has been designed and manufactured for general electronic devices, such as home electronics, soffice equipment, information device and communication devices. In an event that this product is used for more sophisticated applications requiring higher safety and reliability and its failure or malfunction of this product may impose damage to human life or property, agreement on product specifications for approval suitable for such applications are required. Such applications shall include the following: aircraft equipment, aerospace equipment, disaster prevention / crime prevention equipment, medical equipment, transportation equipment (vehicles, trains, ships, etc.), information processing equipment that are highly publicized, and other equivalent equipment - Regardless of its applications, in an event that this product is used for the equipment requiring high safety levels, place protective circuits or redundant circuits and perform safety tests to improve your products safety. <p>1.3 Handling of approval specification</p> <ul style="list-style-type: none"> • Writings in this specification form are subject to change through precautions. • This specification form specify this item only. Please perform your approval test in the actual application conditions beforehand. • Please return one copy of this specification form with your approval stamp or signature to us. Otherwise, it might be happened that the item can not be supplied. <p>1.4 Manufacturing Sites</p> <p>The country of manufacture : Japan Input Devices Division Electromechanical Components Business Division Panasonic Corporation</p> <p>2. Summary</p> <p>2.1 This specifications applies to the following types of switch. Push-ON type S.P.S.T</p> <p>2.2 This specifications is a constituent document of contract for business concluded between your company and Panasonic Corporation.</p> <p>2.3 Items not particularly specified in this specifications shall be in conformance with JIS Standards.</p>		

Classification

SPECIFICATION

Issue No.

20150092

Part Name 4.5mm x 2.2mm Side-operational
Edge-mount Light Touch Switch

Part No.

EVPAEGE2A

2 / 8

3. Dimension • Marking • Circuit diagram

Date code are indicated in the product.

General dimension tolerance : ± 0.2

() dimensions are reference dimensions.

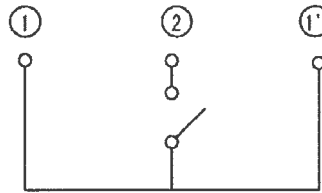
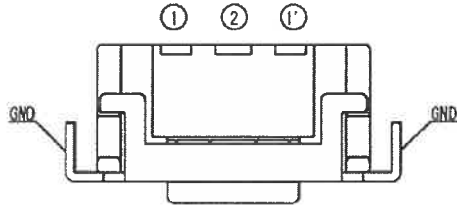

Circuit Diagram

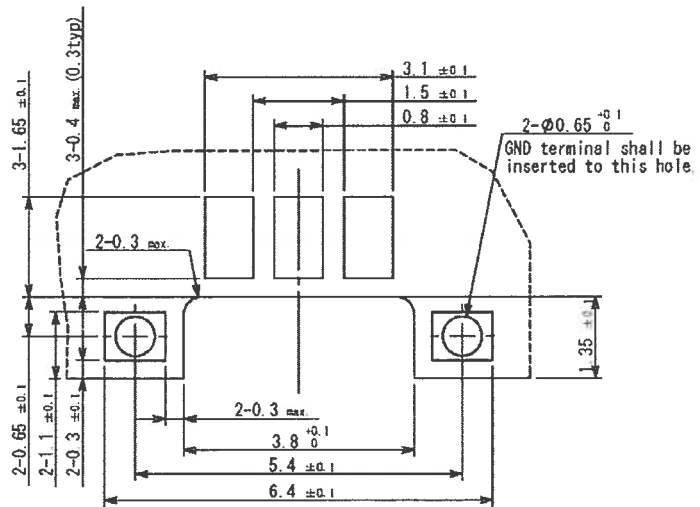
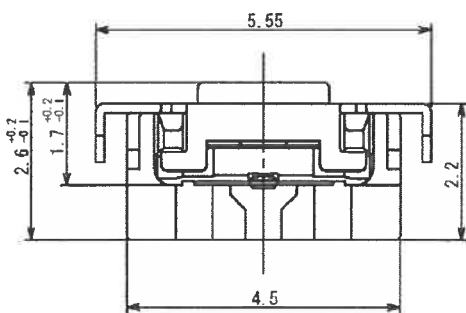
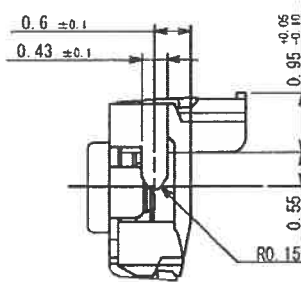
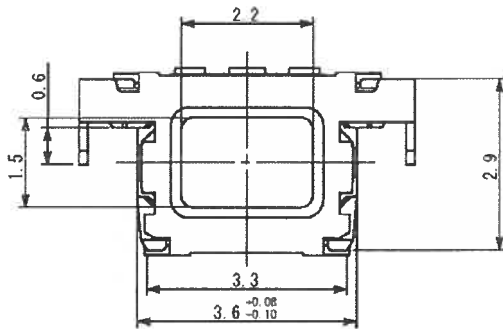

Land pattern plan

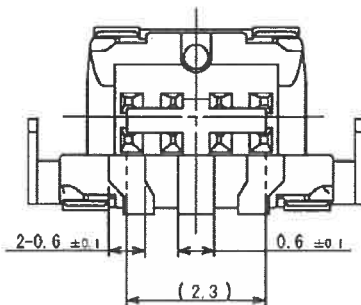

Knob color : Black

Piece weight : about 0.04 g

Solder thickness : $t=0.12 \begin{smallmatrix} +0.03 \\ -0.02 \end{smallmatrix}$

Classification	SPECIFICATION	Issue No. 20150092
Part Name 4.5mm x 2.2mm Side-operational Edge-mount Light Touch Switch	Part No. EVPAEGE2A	4 / 8

5.2 Mechanical characteristics

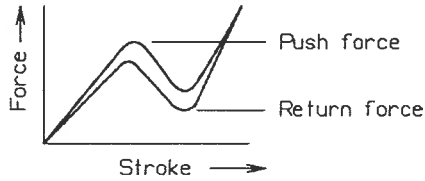
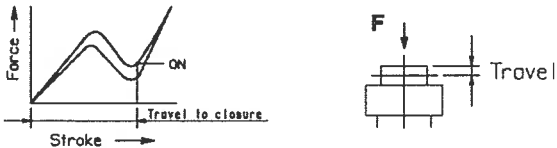
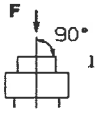
No.	ITEM	TEST CONDITION	PERFORMANCE
5.2.1	Operation force		Push force $1.6 \begin{matrix} + \\ - \end{matrix} \begin{matrix} 0.5 \\ 0.5 \end{matrix} \text{ N}$ Return force 0.1 N min
5.2.2	Travel to closure		$0.13 \begin{matrix} + \\ - \end{matrix} \begin{matrix} 0.1 \\ 0.1 \end{matrix} \text{ mm}$
5.2.3	Push strength	50 N for 60 sec. 	No damage (Electrical and mechanical)
5.2.4	Vibration test	1) Amplitude : 1.5 mm 2) Sweep rate : 10-55-10Hz for 1 minute 3) Sweep method : Logarithmic frequency sweep rate 4) Vibration direction : X,Y,Z(3 directions) 5) Time : Each direction 2 hours (Total 6 hours)	No.5.1 and 5.2.1 to 5.2.2 shall be satisfied.
5.2.5	Soldering heat test	Mount the switch on P.W.B by solder paste. 1) Reflow process 3 times. (Refer to section 6.1) 2) Standard conditions after test : 1 hours	Contact resistance 1000 mΩ max. No.5.1.2 to 5.1.4 and No.5.2.1 to 5.2.2 shall be satisfied.
5.2.6	Solderbilty	After spreading flux, the terminal is immersed in solder with following condition. Solder bar : M705/Sn-3.0Ag-0.5Cu (Senju Metal Industry Co.,Ltd.) Flux : CF-110VH-2A (tamura kaken) Soldering temperture : 260±5 °C Soldering time : 2±0.5 sec.	95% or more of surface area(Excluding ruptured surface)where is immersed in solder shall be covered by new solder.

Classification	SPECIFICATION	Issue No. 20150092
Part Name 4.5mm x 2.2mm Side-operational Edge-mount Light Touch Switch	Part No. EVPAEGE2A	5 / 8

5.3 Climatic characteristics

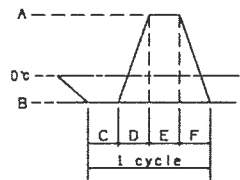
No.	ITEM	TEST CONDITION	PERFORMANCE
5.3.1	Cold test	1) Temperature : $-40\pm 2\text{ }^{\circ}\text{C}$ 2) Duration of test : 500h 3) Take off a drop water. 4) Standard conditions after test : 1 h	Contact resistance 2000 m Ω max. No.5.1.2 to 5.1.4 and No.5.2.1 to 5.2.2 shall be satisfied.
5.3.2	Heat test	1) Temperature : $85\pm 2\text{ }^{\circ}\text{C}$ 2) Duration of test : 500h 3) Standard conditions after test : 1 h	Contact resistance 2000 m Ω max. No.5.1.2 to 5.1.4 and No.5.2.1 to 5.2.2 shall be satisfied.
5.3.3	Heat shock test	1) Test cycles : 20 cycles 2) Standard conditions after test : 1 h  A: $+85\pm 2\text{ }^{\circ}\text{C}$ B: $-40\pm 2\text{ }^{\circ}\text{C}$ C: 1 hour D: 5 minutes max. E: 1 hour F: 5 minutes max.	Contact resistance 2000 m Ω max. No.5.1.2 to 5.1.4 and No.5.2.1 to 5.2.2 shall be satisfied.
5.3.4	Humidity test	1) Temperature : $60\pm 2\text{ }^{\circ}\text{C}$ 2) Relative humidity : 90~95 % 3) Duration of test : 500 h 4) Take off a drop water. 5) Standard conditions after test : 1 h	Contact resistance 2000 m Ω max. No.5.1.2 to 5.1.4 and No.5.2.1 to 5.2.2 shall be satisfied.
5.3.5	Endurance (Switching action)	1) DC 15 V 20 mA Resistance load 2) Operation speed : 2~3 times/s 3) Push force : Maximum value of operation force 4) Operation number : 200,000 times	Contact resistance 20 Ω max. Bouncing : 10 ms max. Variation rate of operation force shall be within $\pm 30\%$ to the value before testing No.5.1.2 and 5.2.2 shall be satisfied.
5.3.6	Withstand H ₂ S	1) Density : 3 \pm 1ppm 2) Temperature : $40\pm 2\text{ }^{\circ}\text{C}$ 3) Relative humidity : 80~85 % 4) Duration of test : 24 h 5) Standard conditions after test : 1 h	Contact resistance 2000 m Ω max. No.5.1.2 to 5.1.4 and No.5.2.1 to 5.2.2 shall be satisfied.

Classification	SPECIFICATION	Issue No. 20150092
Part Name 4.5mm x 2.2mm Side-operational Edge-mount Light Touch Switch	Part No. EVPAEGE2A	6 / 8

6. Prohibitions and precaution for handling

6.1 Reflow soldering condition

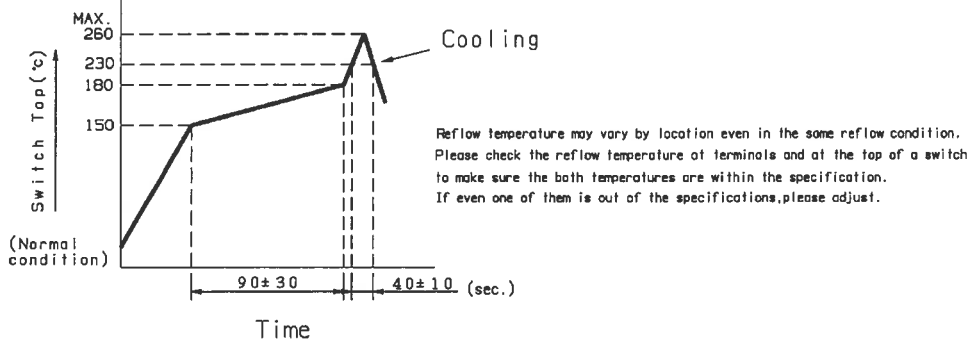

- 1) Three times max. with directing the switch mounting side of P.W.B up.
- 2) Re-soldering by soldering iron shall be allowed under 350 °C max. 3 sec. max. 1 time only and the tip of iron must not touch to terminals.
Soldering iron for re-soldering have to be 60 W max.

6.2 Design instructions

- 1) Please refer to the land pattern plan Panasonic recommends on the 2nd page.
- 2) Design key top as fig-1. Design inclination of key top 4 deg. max. as fig-2.

Deviation between center of key top and switch should be within 0.3 mm.

(Recommended operation condition)

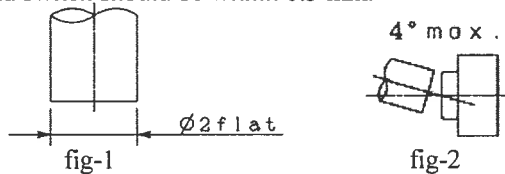

6.3 Note

- 1) Please be cautions not to give excessive static load or shock to switches.
- 2) Please be careful not to pile up P.W.B. after switches were soldered.
- 3) Preservation under high temperature and high humidity or corrosive gas should be avoided especially.
When you need to preserve for a long period, do not open the carton.
- 4) Avoid pressing the film portion of the product with sharp-edged object.
- 5) Cleaning
 - If flux or solder is scattered on the surface of P.W.B when soldering, characteristics of this product may be damaged.
 - Cleaning after soldering is not allowed. When cleaning is required this switch should be soldered after the cleaning.
- 6) Avoid the use of the switch under pushed ON condition is continued for a long time.
- 7) There is a possibility the flux from solder paste infiltrates into the body if plenty of solder paste was applied by switch on the P.W.B.
So we recommend to use our proposed land design in order to prevent above problem.
Also please avoid putting additional land by the switch on the P.W.B.

Classification	SPECIFICATION	Issue No. 20150092
Part Name 4.5mm x 2.2mm Side-operational Edge-mount Light Touch Switch	Part No. EVPAEGE2A	7 / 8

7. Packing specification

Carrier tape

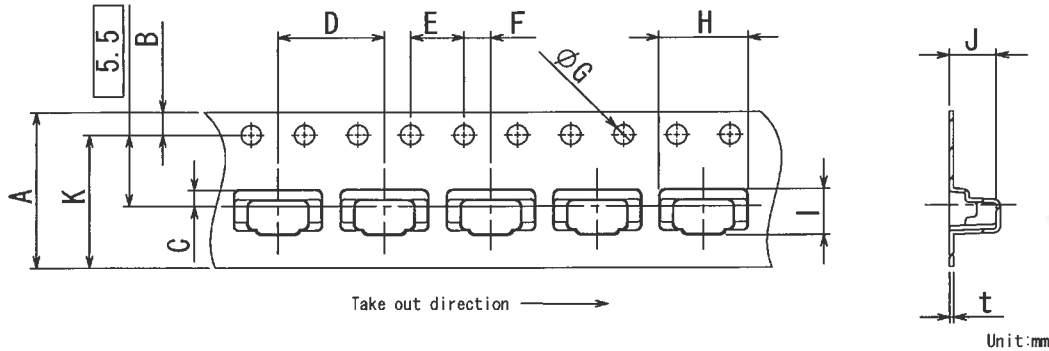

A	B	C	D	E	F	G	H	I	J	t	K
± 0.3 12	± 0.1 1.75	± 0.1 0.95	± 0.1 8	± 0.1 4	± 0.1 2	$\begin{smallmatrix} +0.1 \\ 0 \end{smallmatrix}$ 1.5	± 0.2 6.1	± 0.2 2.9	± 0.2 3.3	± 0.1 0.3	(10.25)

Taping condition : Lack of products in the middle of taping should be one MAX, but total quantity specified in the specifications should be secured.
 Peeling off strength of top tape : It should be within 0.2N to 1.0N at 165 degree in peeling off angle.
 Joint of carrier tape : One joint per one reel may exist.

Reel (3500pcs. /reel)

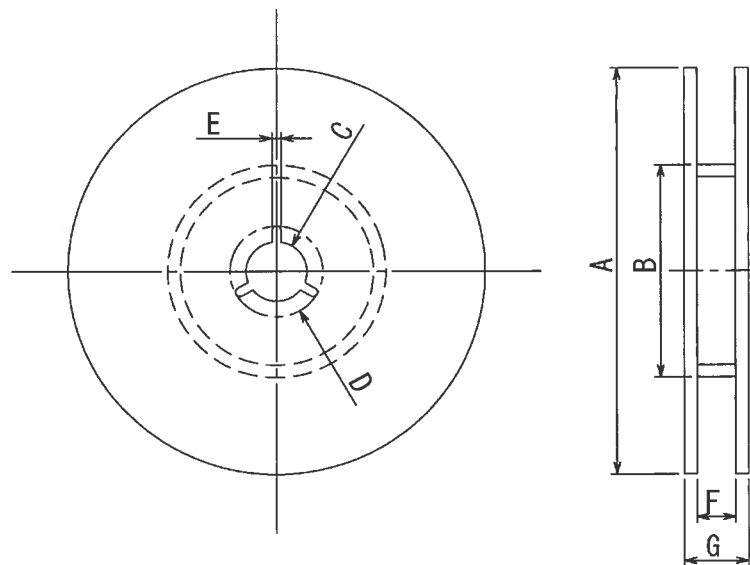

A	B	C	D	E	F	G
± 2 $\phi 380$	± 1 $\phi 80$	± 0.5 $\phi 13$	± 1 $\phi 21$	± 0.5 2	± 1 13.5	± 1 17.5

Classification	SPECIFICATION	Issue No. 20150092
Part Name 4.5mm x 2.2mm Side-operational Edge-mount Light Touch Switch	Part No. EVPAEGE2A	8 / 8
<p><Prohibitions and precaution for handling></p> <p>【Prohibited items on fire and smoking】</p> <ul style="list-style-type: none"> • Absolutely avoid use of a product beyond its rated range because doing so may cause a fire. If misuse or abnormal use may result under conditions in which the product is used out of its rated range, take proper measures such as current interruption using a protective circuit. • The grade of nonflammability for resin used in product is "94HB, " which is based on UL94 Standards (flammability test for plastic materials). Prohibit use in a location where a spreading fire may be generated or prepare against a spreading fire. <p>【For use in equipment for which safety is requested】</p> <ul style="list-style-type: none"> • Although care is taken to ensure product quality, inferior characteristics, short circuits, and open circuits are some problems that might be generated. To design an equipment which places maximum emphasis on safety, review the effect of any single fault of a product in advance and perform virtually fail-safe design to ensure maximum safety by: <ul style="list-style-type: none"> • Preparing a protective circuit or a protective device to improve system safety, and equipment. • Preparing a redundant circuit to improve system safety so that the single fault of a product does not cause a dangerous situation. <p>【Attentions required for storage condition】</p> <ul style="list-style-type: none"> • When this product is to be stored in the following circumstances and conditions, it may affect on the performance deteriorations and solderability etc., avoid storing in the following conditions. <ol style="list-style-type: none"> (1) A place where the temperature is -10°C max., +40°C min. and the humidity is 85% min. (2) In the corrosive gas atmosphere. (3) Long-term storage for 6 months min. (4) A place where the product is exposed to direct sunlight. • Store in packed condition so that the load stress is not applied. • Please use this product as soon as possible, our recommendation is within 3 months and the limitation is 6 months. • If any remainder left after packing is opened, store it with proper moistureproofing and gasproofing, etc., 		

Данный компонент на территории Российской Федерации

Вы можете приобрести в компании MosChip.

Для оперативного оформления запроса Вам необходимо перейти по данной ссылке:

<http://moschip.ru/get-element>

Вы можете разместить у нас заказ для любого Вашего проекта, будь то серийное производство или разработка единичного прибора.

В нашем ассортименте представлены ведущие мировые производители активных и пассивных электронных компонентов.

Нашей специализацией является поставка электронной компонентной базы двойного назначения, продукции таких производителей как XILINX, Intel (ex.ALTERA), Vicor, Microchip, Texas Instruments, Analog Devices, Mini-Circuits, Amphenol, Glenair.

Сотрудничество с глобальными дистрибьюторами электронных компонентов, предоставляет возможность заказывать и получать с международных складов практически любой перечень компонентов в оптимальные для Вас сроки.

На всех этапах разработки и производства наши партнеры могут получить квалифицированную поддержку опытных инженеров.

Система менеджмента качества компании отвечает требованиям в соответствии с ГОСТ Р ИСО 9001, ГОСТ РВ 0015-002 и ЭС РД 009

Офис по работе с юридическими лицами:

105318, г.Москва, ул.Щербаковская д.3, офис 1107, 1118, ДЦ «Щербаковский»

Телефон: +7 495 668-12-70 (многоканальный)

Факс: +7 495 668-12-70 (доб.304)

E-mail: info@moschip.ru

Skype отдела продаж:

moschip.ru

moschip.ru_4

moschip.ru_6

moschip.ru_9