

# TLE9861QXA20

Microcontroller with PWM Interface and H-Bridge MOSFET Driver for Automotive Applications

BF-Step

## Data Sheet

Rev. 1.0, 2017-03-03

Automotive Power

## Table of Contents

|           |   |           |
|-----------|---|-----------|
| <b>1</b>  | <b>Overview</b> .....                                       | <b>6</b>  |
| 1.1       | Abbreviations .....   | 8         |
| <b>2</b>  | <b>Block Diagram</b> .....                                  | <b>10</b> |
| <b>3</b>  | <b>Device Pinout and Pin Configuration</b> .....            | <b>11</b> |
| 3.1       | Device Pinout .....   | 11        |
| 3.2       | Pin Configuration .....                                     | 12        |
| <b>4</b>  | <b>Modes of Operation</b> .....                             | <b>15</b> |
| <b>5</b>  | <b>Power Management Unit (PMU)</b> .....                    | <b>18</b> |
| 5.1       | Features .....  | 18        |
| 5.2       | Introduction .....  | 18        |
| 5.2.1     | Block Diagram .....   | 19        |
| 5.2.2     | PMU Modes Overview .....                                    | 21        |
| 5.3       | Power Supply Generation Unit (PGU) .....                    | 22        |
| 5.3.1     | Voltage Regulator 5.0V (VDDP) .....                         | 22        |
| 5.3.2     | Voltage Regulator 1.5V (VDDC) .....                         | 23        |
| 5.3.3     | External Voltage Regulator 5.0V (VDDEXT) .....              | 24        |
| <b>6</b>  | <b>System Control Unit - Digital Modules (SCU-DM)</b> ..... | <b>25</b> |
| 6.1       | Features .....  | 25        |
| 6.2       | Introduction .....  | 25        |
| 6.2.1     | Block Diagram .....   | 26        |
| 6.3       | Clock Generation Unit .....                                 | 27        |
| 6.3.1     | Low Precision Clock .....                                   | 28        |
| 6.3.2     | High Precision Oscillator Circuit (OSC_HP) .....            | 28        |
| 6.3.2.1   | External Input Clock Mode .....                             | 28        |
| 6.3.2.2   | External Crystal Mode .....                                 | 28        |
| <b>7</b>  | <b>System Control Unit - Power Modules (SCU-PM)</b> .....   | <b>30</b> |
| 7.1       | Features .....  | 30        |
| 7.2       | Introduction .....  | 30        |
| 7.2.1     | Block Diagram .....   | 30        |
| <b>8</b>  | <b>ARM Cortex-M3 Core</b> .....                             | <b>32</b> |
| 8.1       | Features .....  | 32        |
| 8.2       | Introduction .....  | 33        |
| 8.2.1     | Block Diagram .....   | 33        |
| <b>9</b>  | <b>DMA Controller</b> .....                                 | <b>34</b> |
| 9.1       | Features .....  | 34        |
| 9.2       | Introduction .....  | 35        |
| 9.2.1     | Block Diagram .....   | 35        |
| 9.3       | Functional Description .....                                | 36        |
| 9.3.1     | DMA Mode Overview .....                                     | 36        |
| <b>10</b> | <b>Address Space Organization</b> .....                     | <b>37</b> |
| <b>11</b> | <b>Memory Control Unit</b> .....                            | <b>38</b> |
| 11.1      | Features .....  | 38        |
| 11.2      | Introduction .....  | 38        |
| 11.2.1    | Block Diagram .....   | 38        |
| 11.3      | NVM Module (Flash Memory) .....                             | 40        |

|           |  |    |
|-----------|--|----|
| <b>12</b> | <b>Interrupt System</b>                    | 41 |
| 12.1      | Features                                   | 41 |
| 12.2      | Introduction                               | 41 |
| 12.2.1    | Overview                                   | 41 |
| <b>13</b> | <b>Watchdog Timer (WDT1)</b>               | 43 |
| 13.1      | Features                                   | 43 |
| 13.2      | Introduction                               | 44 |
| <b>14</b> | <b>GPIO Ports and Peripheral I/O</b>       | 45 |
| 14.1      | Features                                   | 45 |
| 14.2      | Introduction                               | 45 |
| 14.2.1    | Port 0 and Port 1                          | 45 |
| 14.2.2    | Port 2                                     | 47 |
| 14.3      | TLE9861QXA20 Port Module                   | 48 |
| 14.3.1    | Port 0                                     | 48 |
| 14.3.1.1  | Port 0 Functions                           | 48 |
| 14.3.2    | Port 1                                     | 50 |
| 14.3.2.1  | Port 1 Functions                           | 50 |
| 14.3.3    | Port 2                                     | 52 |
| 14.3.3.1  | Port 2 Functions                           | 52 |
| <b>15</b> | <b>General Purpose Timer Units (GPT12)</b> | 53 |
| 15.1      | Features                                   | 53 |
| 15.1.1    | Features Block GPT1                        | 53 |
| 15.1.2    | Features Block GPT2                        | 53 |
| 15.2      | Introduction                               | 53 |
| 15.2.1    | Block Diagram GPT1                         | 54 |
| 15.2.2    | Block Diagram GPT2                         | 55 |
| <b>16</b> | <b>Timer2 and Timer21</b>                  | 56 |
| 16.1      | Features                                   | 56 |
| 16.2      | Introduction                               | 56 |
| 16.2.1    | Timer2 and Timer21 Modes Overview          | 56 |
| <b>17</b> | <b>Timer3</b>                              | 57 |
| 17.1      | Features                                   | 57 |
| 17.2      | Introduction                               | 57 |
| 17.3      | Functional Description                     | 57 |
| 17.3.1    | Timer3 Modes Overview                      | 57 |
| <b>18</b> | <b>Capture/Compare Unit 6 (CCU6)</b>       | 59 |
| 18.1      | Feature Set Overview                       | 59 |
| 18.2      | Introduction                               | 59 |
| 18.2.1    | Block Diagram                              | 60 |
| <b>19</b> | <b>UART1/UART2</b>                         | 61 |
| 19.1      | Features                                   | 61 |
| 19.2      | Introduction                               | 61 |
| 19.2.1    | Block Diagram                              | 61 |
| 19.3      | UART Modes                                 | 62 |
| <b>20</b> | <b>High Voltage PWM Interface</b>          | 63 |
| 20.1      | Features                                   | 63 |
| 20.2      | Introduction                               | 63 |
| 20.2.1    | Block Diagram                              | 64 |

|           |  |    |
|-----------|--|----|
| <b>21</b> | <b>High-Speed Synchronous Serial Interface (SSC1/SSC2)</b> | 65 |
| 21.1      | Features   | 65 |
| 21.2      | Introduction   | 66 |
| 21.2.1    | Block Diagram  | 66 |
| <b>22</b> | <b>Measurement Unit</b>                                    | 67 |
| 22.1      | Features   | 67 |
| 22.2      | Introduction   | 67 |
| 22.2.1    | Block Diagram  | 68 |
| <b>23</b> | <b>Measurement Core Module (incl. ADC2)</b>                | 69 |
| 23.1      | Features   | 69 |
| 23.2      | Introduction   | 69 |
| 23.2.1    | Block Diagram  | 69 |
| 23.2.2    | Measurement Core Module Modes Overview                     | 70 |
| <b>24</b> | <b>10-Bit Analog Digital Converter (ADC1)</b>              | 71 |
| 24.1      | Features   | 71 |
| 24.2      | Introduction   | 71 |
| 24.2.1    | Block Diagram  | 72 |
| <b>25</b> | <b>High-Voltage Monitor Input</b>                          | 73 |
| 25.1      | Features   | 73 |
| 25.2      | Introduction   | 73 |
| 25.2.1    | Block Diagram  | 73 |
| <b>26</b> | <b>Bridge Driver (incl. Charge Pump)</b>                   | 74 |
| 26.1      | Features   | 74 |
| 26.2      | Introduction   | 74 |
| 26.2.1    | Block Diagram  | 75 |
| 26.2.2    | General  | 75 |
| <b>27</b> | <b>Current Sense Amplifier</b>                             | 76 |
| 27.1      | Features   | 76 |
| 27.2      | Introduction   | 76 |
| 27.2.1    | Block Diagram  | 76 |
| <b>28</b> | <b>Application Information</b>                             | 77 |
| 28.1      | H-Bridge Driver  | 77 |
| 28.2      | ESD Immunity According to IEC61000-4-2                     | 79 |
| <b>29</b> | <b>Electrical Characteristics</b>                          | 80 |
| 29.1      | General Characteristics                                    | 80 |
| 29.1.1    | Absolute Maximum Ratings                                   | 80 |
| 29.1.2    | Functional Range   | 83 |
| 29.1.3    | Current Consumption  | 84 |
| 29.1.4    | Thermal Resistance   | 86 |
| 29.1.5    | Timing Characteristics                                     | 86 |
| 29.2      | Power Management Unit (PMU)                                | 87 |
| 29.2.1    | PMU I/O Supply (VDDP) Parameters                           | 87 |
| 29.2.2    | PMU Core Supply (VDDC) Parameters                          | 89 |
| 29.2.3    | VDDEXT Voltage Regulator (5.0V) Parameters                 | 90 |
| 29.2.4    | VPRE Voltage Regulator (PMU Subblock) Parameters           | 92 |
| 29.2.4.1  | Load Sharing Scenarios of VPRE Regulator                   | 92 |
| 29.2.5    | Power Down Voltage Regulator (PMU Subblock) Parameters     | 93 |
| 29.3      | System Clocks  | 94 |

**Table of Contents**

|           |  |            |
|-----------|--|------------|
| 29.3.1    | Oscillators and PLL Parameters                 | 94         |
| 29.3.2    | External Clock Parameters XTAL1, XTAL2         | 95         |
| 29.4      | Flash Memory                                   | 96         |
| 29.4.1    | Flash Parameters                               | 96         |
| 29.5      | Parallel Ports (GPIO)                          | 97         |
| 29.5.1    | Description of Keep and Force Current          | 97         |
| 29.5.2    | DC Parameters of Port 0, Port 1, TMS and Reset | 98         |
| 29.5.3    | DC Parameters of Port 2                        | 100        |
| 29.6      | PWM Interface                                  | 102        |
| 29.6.1    | Electrical Characteristics                     | 102        |
| 29.7      | High-Speed Synchronous Serial Interface        | 106        |
| 29.7.1    | SSC Timing Parameters                          | 106        |
| 29.8      | Measurement Unit                               | 107        |
| 29.8.1    | System Voltage Measurement Parameters          | 107        |
| 29.8.2    | Central Temperature Sensor Parameters          | 111        |
| 29.8.3    | ADC2-VBG                                       | 112        |
| 29.8.3.1  | ADC2 Reference Voltage VBG                     | 112        |
| 29.8.3.2  | ADC2 Specifications                            | 112        |
| 29.9      | ADC1 Reference Voltage - VAREF                 | 113        |
| 29.9.1    | Electrical Characteristics VAREF               | 113        |
| 29.9.2    | Electrical Characteristics ADC1 (10-Bit)       | 114        |
| 29.10     | Reserved                                       | 115        |
| 29.11     | High-Voltage Monitoring Input                  | 116        |
| 29.11.1   | Electrical Characteristics                     | 116        |
| 29.12     | MOSFET Driver                                  | 117        |
| 29.12.1   | Electrical Characteristics                     | 117        |
| 29.13     | Operational Amplifier                          | 122        |
| 29.13.1   | Electrical Characteristics                     | 122        |
| <b>30</b> | <b>Package Outlines</b>                        | <b>124</b> |
| <b>31</b> | <b>Revision History</b>                        | <b>125</b> |



## 1 Overview

### Summary of Features

- 32 bit ARM Cortex M3 Core
  - up to 24 MHz clock frequency
  - one clock per machine cycle architecture
- On-chip memory
  - 36 kByte Flash including
  - 4 kByte EEPROM (emulated in Flash)
  - 1024 Byte 100 Time Programmable Memory (100TP)
  - 3 kByte RAM
  - Boot ROM for startup firmware and Flash routines
- On-chip OSC and PLL for clock generation
  - PLL loss-of-lock detection
- MOSFET driver including charge pump
- 10 general-purpose I/O Ports (GPIO)
- 5 analog inputs, 10-bit A/D Converter (ADC1)
- 16-bit timers - GPT12, Timer 2, Timer 21 and Timer 3
- Capture/compare unit for PWM signal generation (CCU6)
- 2 full duplex serial interfaces (UART)
- 2 synchronous serial channels (SSC)
- On-chip debug support via 2-wire SWD
- Bidirectional PWM interface
- 1 high voltage monitoring input
- Single power supply from 5.5 V to 27 V
- Extended power supply voltage range from 3 V to 28 V
- Low-dropout voltage regulators (LDO)
- High speed operational amplifier for motor current sensing via shunt
- 5 V voltage supply for external loads (e.g. Hall sensor)
- Core logic supply at 1.5 V
- Programmable window watchdog (WDT1) with independent on-chip clock source
- Power saving modes
  - MCU slow-down Mode
  - Sleep Mode
  - Stop Mode
  - Cyclic wake-up Sleep Mode
- Power-on and undervoltage/brownout reset generator



**VQFN-48-31**

| Type         | Package    | Marking |
|--------------|------------|---------|
| TLE9861QXA20 | VQFN-48-31 |         |

- Overtemperature protection
- Short circuit protection
- Loss of clock detection with fail safe mode entry for low system power consumption
- Temperature Range  $T_j = -40\text{ °C to }+150\text{ °C}$
- Package VQFN-48 with LTI feature
- Green package (RoHS compliant)
- AEC qualified

## 1.1 Abbreviations

The following acronyms and terms are used within this document. List see in [Table 1](#).

**Table 1 Acronyms**

| Acronyms | Name  |
|----------|---|
| AHB      | Advanced High-Performance Bus                       |
| APB      | Advanced Peripheral Bus                             |
| CCU6     | Capture Compare Unit 6                              |
| CGU      | Clock Generation Unit                               |
| CMU      | Cyclic Management Unit                              |
| CP       | Charge Pump for MOSFET driver                       |
| CSA      | Current Sense Amplifier                             |
| DPP      | Data Post Processing                                |
| ECC      | Error Correction Code                               |
| EEPROM   | Electrically Erasable Programmable Read Only Memory |
| EIM      | Exceptional Interrupt Measurement                   |
| FSM      | Finite State Machine                                |
| GPIO     | General Purpose Input Output                        |
| H-Bridge | Half Bridge   |
| ICU      | Interrupt Control Unit                              |
| IEN      | Interrupt Enable                                    |
| IIR      | Infinite Impulse Response                           |
| LDM      | Load Instruction                                    |
| LDO      | Low DropOut voltage regulator                       |
| LSB      | Least Significant Bit                               |
| LTI      | Lead Tip Inspection                                 |
| MCU      | Memory Control Unit                                 |
| MF       | Measurement Functions                               |
| MSB      | Most Significant Bit                                |
| MPU      | Memory Protection Unit                              |
| MRST     | Master Receive Slave Transmit                       |
| MTSR     | Master Transmit Slave Receive                       |
| MU       | Measurement Unit                                    |
| NMI      | Non Maskable Interrupt                              |
| NVIC     | Nested Vector Interrupt Controller                  |
| NVM      | Non-Volatile Memory                                 |
| OTP      | One Time Programmable                               |
| OSC      | Oscillator  |
| PBA      | Peripheral Bridge                                   |
| PCU      | Power Control Unit                                  |



**Table 1 Acronyms**

| <b>Acronyms</b> | <b>Name</b>                                 |
|-----------------|---|
| PD              | Pull Down                                   |
| PGU             | Power supply Generation Unit                |
| PLL             | Phase Locked Loop                           |
| PPB             | Private Peripheral Bus                      |
| PU              | Pull Up                                     |
| PWM             | Pulse Width Modulation                      |
| RAM             | Random Access Memory                        |
| RCU             | Reset Control Unit                          |
| RMU             | Reset Management Unit                       |
| ROM             | Read Only Memory                            |
| SCU-DM          | System Control Unit - Digital Modules       |
| SCU-PM          | System Control Unit - Power Modules         |
| SFR             | Special Function Register                   |
| SOW             | Short Open Window (for WDT)                 |
| SPI             | Serial Peripheral Interface                 |
| SSC             | Synchronous Serial Channel                  |
| STM             | Store Instruction                           |
| SWD             | ARM Serial Wire Debug                       |
| TCCR            | Temperature Compensation Control Register   |
| TMS             | Test Mode Select                            |
| TSD             | Thermal Shut Down                           |
| UART            | Universal Asynchronous Receiver Transmitter |
| VBG             | Voltage reference Band Gap                  |
| VCO             | Voltage Controlled Oscillator               |
| VPRE            | Pre Regulator                               |
| WDT             | Watchdog Timer in SCU-DM                    |
| WDT1            | Watchdog Timer in SCU-PM                    |
| WMU             | Wake-up Management Unit                     |
| 100TP           | 100 Time Programmable                       |

## 2 Block Diagram

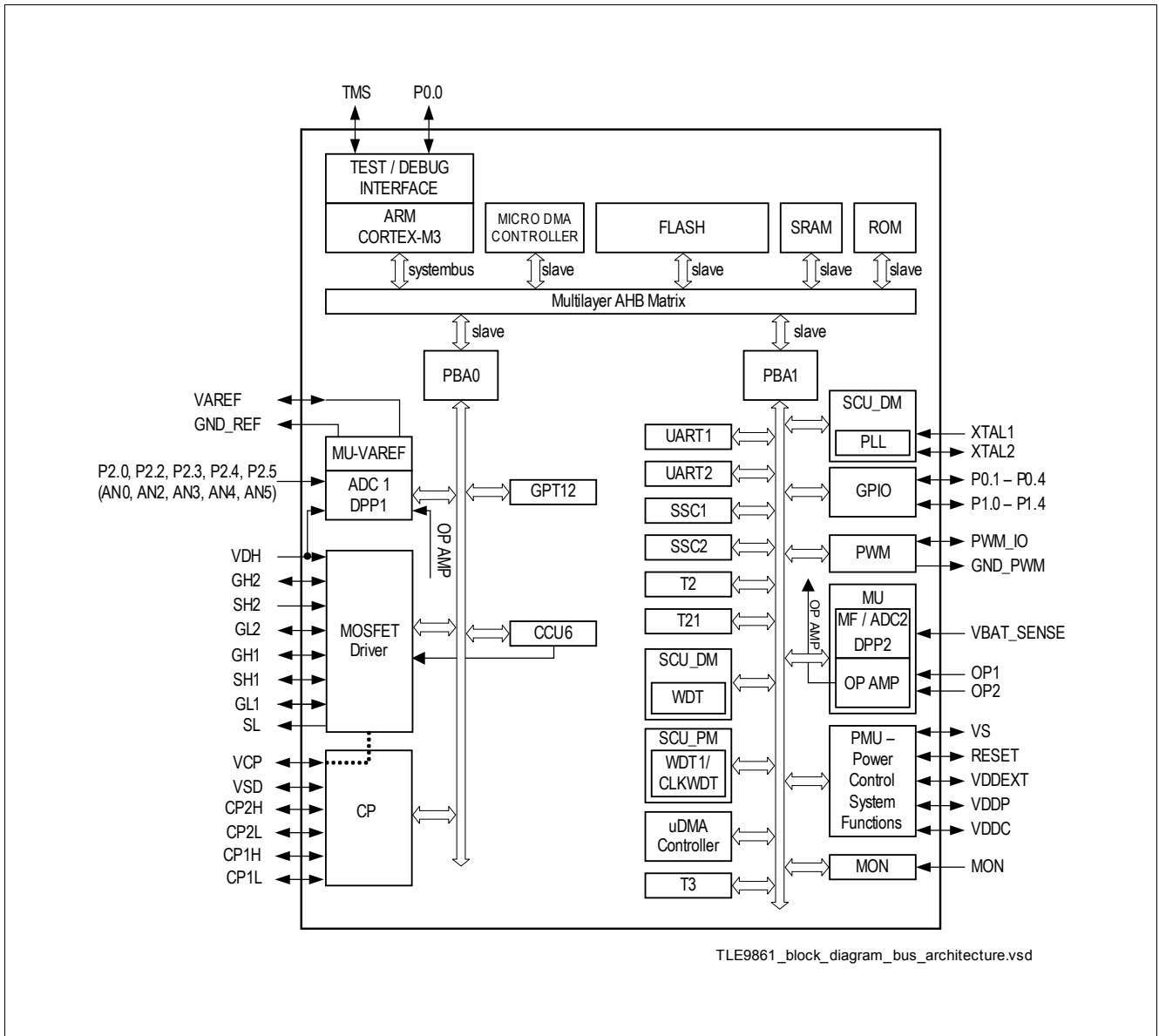

Figure 1 Block Diagram

### 3 Device Pinout and Pin Configuration

#### 3.1 Device Pinout

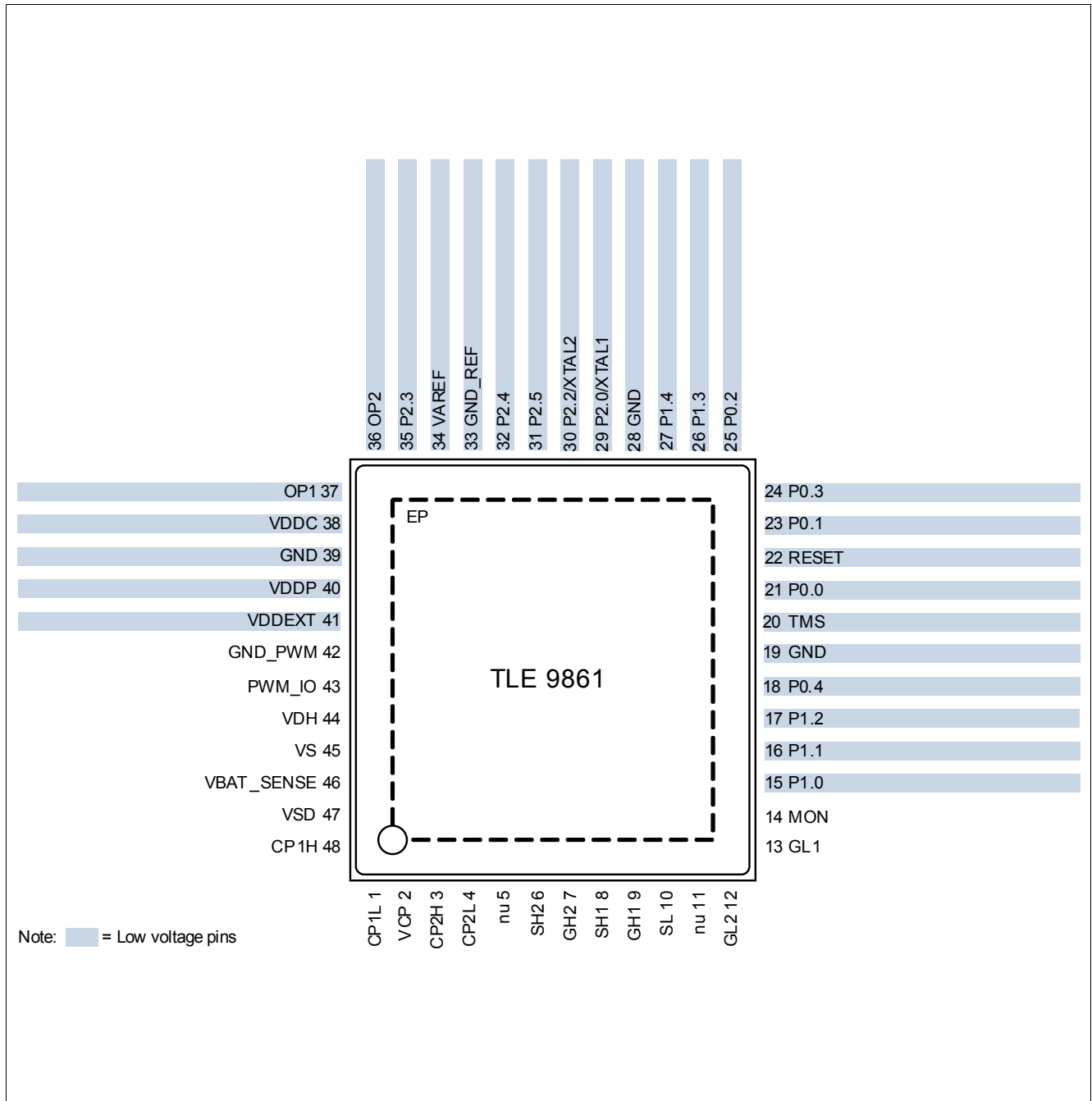

Figure 2 Device Pinout

### 3.2 Pin Configuration

After reset, all pins are configured as input (except supply pin) with one of the following settings:

- Pull-up device enabled only (PU)
- Pull-down device enabled only (PD)
- Input with both pull-up and pull-down devices disabled (I)
- Output with output stage deactivated = high impedance state (Hi-Z)

The functions and default states of the TLE9861QXA20 external pins are provided in the following table.

Type: indicates the pin type.

- I/O: Input or output
- I: Input only
- O: Output only
- P: Power supply

Not all alternate functions listed.

**Table 2 Pin Definitions and Functions**

| Symbol    | Pin Number | Type | Reset State <sup>1)</sup> | Function   |
|-----------|------------|------|---------------------------|--|
| <b>P0</b> |            |      |                           | <b>Port 0</b><br>Port 0 is a 5-bit bidirectional general purpose I/O port. Alternate functions can be assigned and are listed in the port description. Main function is listed below.            |
| P0.0      | 21         | I/O  | I/PU                      | SWD Serial Wire Debug Clock  |
| P0.1      | 23         | I/O  | I/PU                      | GPIO General Purpose IO<br>Alternate function mapping see <a href="#">Table 8</a>  |
| P0.2      | 25         | I/O  | I/PD                      | GPIO General Purpose IO<br>Alternate function mapping see <a href="#">Table 8</a><br><i>Note: For a functional SWD connection this GPIO must be tied to zero!</i>                                |
| P0.3      | 24         | I/O  | I/PU                      | GPIO General Purpose IO<br>Alternate function mapping see <a href="#">Table 8</a>  |
| P0.4      | 18         | I/O  | I/PD                      | GPIO General Purpose IO<br>Alternate function mapping see <a href="#">Table 8</a>  |
| <b>P1</b> |            |      |                           | <b>Port 1</b><br>Port 1 is a 5-bit bidirectional general purpose I/O port. Alternate functions can be assigned and are listed in the Port description. The principal functions are listed below. |
| P1.0      | 15         | I/O  | I                         | GPIO General Purpose IO<br>Alternate function mapping see <a href="#">Table 9</a>  |
| P1.1      | 16         | I/O  | I                         | GPIO General Purpose IO<br>Alternate function mapping see <a href="#">Table 9</a>  |
| P1.2      | 17         | I/O  | I                         | GPIO General Purpose IO<br>Alternate function mapping see <a href="#">Table 9</a>  |
| P1.3      | 26         | I/O  | I                         | GPIO General Purpose IO, used for Inrush Transistor<br>Alternate function mapping see <a href="#">Table 9</a>  |
| P1.4      | 27         | I/O  | I                         | GPIO General Purpose IO<br>Alternate function mapping see <a href="#">Table 9</a>  |

## Device Pinout and Pin Configuration

**Table 2 Pin Definitions and Functions (cont'd)**

| Symbol               | Pin Number | Type | Reset State <sup>1)</sup> | Function   |
|----------------------|------------|------|---------------------------|--|
| <b>P2</b>            |            |      |                           | <b>Port 2</b><br>Port 2 is a 5-bit general purpose input-only port. Alternate functions can be assigned and are listed in the Port description. Main function is listed below. |
| P2.0/XTAL1           | 29         | I/I  | I                         | AN0 ADC analog input 0<br>Alternate function mapping see <a href="#">Table 10</a>  |
| P2.2/XTAL2           | 30         | I/O  | I                         | AN2 ADC analog input 2<br>Alternate function mapping see <a href="#">Table 10</a>  |
| P2.3                 | 35         | I    | I                         | AN3 ADC analog input 3<br>Alternate function mapping see <a href="#">Table 10</a>  |
| P2.4                 | 32         | I    | I                         | AN4 ADC analog input 4<br>Alternate function mapping see <a href="#">Table 10</a>  |
| P2.5                 | 31         | I    | I                         | AN5 ADC analog input 5<br>Alternate function mapping see <a href="#">Table 10</a>  |
| <b>Power Supply</b>  |            |      |                           |  |
| VS                   | 45         | P    | –                         | Battery supply input   |
| VDDP                 | 40         | P    | –                         | <sup>2)</sup> I/O port supply (5.0 V). Connect external buffer capacitor.  |
| VDDC                 | 38         | P    | –                         | <sup>3)</sup> Core supply (1.5 V during Active Mode).<br>Do not connect external loads, connect external buffer capacitor.   |
| VDDEXT               | 41         | P    | –                         | External voltage supply output (5.0 V, 20 mA)  |
| GND                  | 19         | P    | –                         | GND digital  |
| GND                  | 28         | P    | –                         | GND digital  |
| GND                  | 39         | P    | –                         | GND analog   |
| <b>Monitor Input</b> |            |      |                           |  |
| MON                  | 14         | I    | –                         | High Voltage Monitor Input   |
| <b>PWM Interface</b> |            |      |                           |  |
| PWM_IO               | 43         | I/O  | –                         | PWM interface input/output   |
| GND_PWM              | 42         | P    | –                         | PWM ground   |
| <b>Charge Pump</b>   |            |      |                           |  |
| CP1H                 | 48         | P    | –                         | Charge Pump Capacity 1 High, connect external C  |
| CP1L                 | 1          | P    | –                         | Charge Pump Capacity 1 Low, connect external C   |
| CP2H                 | 3          | P    | –                         | Charge Pump Capacity 2 High, connect external C  |
| CP2L                 | 4          | P    | –                         | Charge Pump Capacity 2 Low, connect external C   |
| VCP                  | 2          | P    | –                         | Charge Pump Capacity   |
| VSD                  | 47         | P    | –                         | Battery supply input for Charge Pump   |
| <b>MOSFET Driver</b> |            |      |                           |  |
| VDH                  | 44         | P    | –                         | Voltage Drain High Side MOSFET Driver  |
| SH2                  | 6          | P    | –                         | Source High Side FET 2   |
| GH2                  | 7          | P    | –                         | Gate High Side FET 2   |

**Table 2 Pin Definitions and Functions (cont'd)**

| Symbol        | Pin Number | Type     | Reset State <sup>1)</sup> | Function   |
|---------------|------------|----------|---------------------------|--|
| SH1           | 8          | P        | –                         | Source High Side FET 1   |
| GH1           | 9          | P        | –                         | Gate High Side FET 1   |
| SL            | 10         | P        | –                         | Source Low Side FET  |
| GL2           | 12         | P        | –                         | Gate Low Side FET 2  |
| GL1           | 13         | P        | –                         | Gate Low Side FET 1  |
| <b>Others</b> |            |          |                           |  |
| GND_REF       | 33         | P        | –                         | GND for VAREF  |
| VAREF         | 34         | I/O      | –                         | 5V ADC1 reference voltage, optional buffer or input              |
| OP1           | 37         | I        | –                         | Negative operational amplifier input                             |
| OP2           | 36         | I        | –                         | Positive operational amplifier input                             |
| TMS           | 20         | I<br>I/O | I/PD                      | TMS Test Mode Select input<br>SWD Serial Wire Debug input/output |
| RESET         | 22         | I/O      | –                         | Reset input, not available during Sleep Mode                     |
| VBAT_SENSE    | 46         | I        | –                         | Battery supply voltage sense input                               |
| EP            | –          | –        | –                         | Exposed Pad, connect to GND                                      |

1) Only valid for digital IOs

2) Also named VDD5V.

3) Also named VDD1V5.

## 4 Modes of Operation

This highly integrated circuit contains analog and digital functional blocks. An embedded 32-bit microcontroller is available for system and interface control. On-chip, low-dropout regulators are provided for internal and external power supply. An internal oscillator provides a cost effective clock that is particularly well suited for PWM communications. A PWM interface is available as a communication interface. Driver stages for an H-Bridge with external MOSFET are integrated, featuring PWM capability, protection features and a charge pump for operation at low supply voltage. A 10-bit SAR ADC is implemented for high precision sensor measurement. An 8-bit ADC is used for diagnostic measurements.

The Micro Controller Unit supervision and system protection (including a reset feature) is complemented by a programmable window watchdog. A cyclic wake-up circuit, supply voltage supervision and integrated temperature sensors are available on-chip.

All relevant modules offer power saving modes in order to support automotive applications connected to terminal 30. A wake-up from power-save mode is possible via a PWM interface, via the monitoring input or using a programmable time period (cyclic wake-up).

Featuring LTI, the integrated circuit is available in a VQFN-48-31 package with 0.5 mm pitch, and is designed to withstand the severe conditions of automotive applications.

The TLE9861QXA20 has several operation modes mainly to support low power consumption requirements.

### Reset Mode

The Reset Mode is a transition mode used e.g. during power-up of the device after a power-on reset, or after wake-up from Sleep Mode. In this mode, the on-chip power supplies are enabled and all other modules are initialized. Once the core supply VDDC is stable, the device enters Active Mode. If the watchdog timer WDT1 fails more than four times, the device performs a fail-safe transition to Sleep Mode.

### Active Mode

In Active Mode, all modules are activated and the TLE9861QXA20 is fully operational.

### Stop Mode

Stop Mode is one of two major low power modes. The transition to the low power modes is performed by setting the corresponding bits in the mode control register. In Stop Mode the embedded microcontroller is still powered, allowing faster wake-up response times. Wake-up from this mode is possible through LIN bus activity, by using the high-voltage monitoring pin or the corresponding 5V GPIOs.

#### Stop Mode with Cyclic Wake-Up

The Cyclic Wake-Up Mode is a special operating mode of the Stop Mode. The transition to the Cyclic Wake-Up Mode is done by first setting the corresponding bits in the mode control register followed by the Stop Mode command. In addition to the cyclic wake-up behavior (wake-up after a programmable time period), asynchronous wake events via the activated sources (LIN and/or MON) are available, as in normal Stop Mode.

### Sleep Mode

The Sleep Mode is a low-power mode. The transition to the low-power mode is done by setting the corresponding bits in the MCU mode control register or in case of failure, see below. In Sleep Mode the embedded microcontroller power supply is deactivated allowing the lowest system power consumption. A wake-up from this mode is possible by PWM Interface activity, the High Voltage Monitor Input pin or Cyclic Wake-up.

#### Sleep Mode in Case of Failure

Sleep Mode is activated after 5 consecutive watchdog failures or in case of supply failure (5 times). In this case, MON is enabled as the wake source and Cyclic Wake-Up is activated with 1s of wake time.

### Sleep Mode with Cyclic Wake-Up

The Cyclic Wake-Up Mode is a special operating mode of the Sleep Mode. The transition to Cyclic Wake-Up Mode is performed by first setting the corresponding bits in the mode control register followed by the Sleep and Stop Mode command. In addition to the cyclic wake-up behavior (wake-up after a programmable time period), asynchronous wake events via the activated sources (PWM interface and/or MON) are available, as in normal Sleep Mode.

When using Sleep Mode with cyclic wake-up the voltage regulator is switched off and started again with the wake. A limited number of registers is buffered during sleep, and can be used by SW e.g. for counting sleep/wake cycles.

### MCU Slow Down Mode

In MCU Slow Down Mode the MCU frequency is reduced for saving power during operation. PWM communication is still possible. LS MOSFET can be activated.

### Wake-Up Source Prioritization

All wake-up sources have the same priority. In order to handle the asynchronous nature of the wake-up sources, the first wake-up signal will initiate the wake-up sequence. Nevertheless all wake-up sources are latched in order to provide all wake-up events to the application software. The software can clear the wake-up source flags. This is to ensure that no wake-up event is lost.

As default wake-up source, the MON input is activated after power-on reset only. Additionally, the device is in Cyclic Wake-Up Mode with the max. configurable dead time setting.

The following table shows the possible power mode configurations including the Stop Mode.

**Table 3 Power Mode Configurations**

| Module/Function   | Active Mode                     | Stop Mode                           | Sleep Mode             | Comment                      |
|-------------------|---------------------------------|-------------------------------------|------------------------|------------------------------|
| VDDEXT            | ON/OFF                          | ON (no dynamic load)/OFF            | OFF                    | –                            |
| Bridge Driver     | ON/OFF                          | OFF                                 | OFF                    |                              |
| PWM TRx           | ON/OFF                          | wake-up only/<br>OFF                | wake-up only/<br>OFF   | –                            |
| VS sense          | ON/OFF<br>brownout<br>detection | brownout detection                  | POR on VS              | brownout det. done in<br>PCU |
| VBAT_SENSE        | ON/OFF                          | OFF                                 | OFF                    | –                            |
| GPIO 5V (wake-up) | n.a.                            | disabled/static                     | OFF                    | –                            |
| GPIO 5V (active)  | ON                              | ON                                  | OFF                    | –                            |
| WDT1              | ON                              | OFF                                 | OFF                    | –                            |
| CYCLIC WAKE       | n.a.                            | cyclic wake-up/<br>cyclic sense/OFF | cyclic wake-up/<br>OFF | –                            |
| Measurement       | ON <sup>1)</sup>                | OFF                                 | OFF                    | –                            |
| MCU               | ON/slow-<br>down/STOP           | STOP <sup>2)</sup>                  | OFF                    | –                            |
| CLOCK GEN (MC)    | ON                              | OFF                                 | OFF                    | –                            |



**Table 3 Power Mode Configurations (cont'd)**

| Module/Function   | Active Mode | Stop Mode | Sleep Mode | Comment            |
|-------------------|-------------|-----------|------------|--------------------|
| LP_CLK (18 MHz)   | ON          | OFF       | OFF        | WDT1               |
| LP_CLK2 (100 kHz) | ON/OFF      | ON/OFF    | ON/OFF     | for cyclic wake-up |

- 1) May not be switched off due to safety reasons
- 2) MC PLL clock disabled, MC supply reduced to 1.1 V

**Wake-Up Levels and Transitions**

The wake-up can be triggered by rising, falling or both signal edges for the monitor input, by PWM interface or by cyclic wake-up.

## 5 Power Management Unit (PMU)

### 5.1 Features

- System modes control (startup, sleep, stop and active)
- Power management (cyclic wake-up)
- Control of system voltage regulators with diagnosis (overload, short, overvoltage)
- Fail safe mode detection and operation in case of system errors (watchdog fail)
- Wake-up sources configuration and management (PWM Interface, MON, GPIOs)
- System error logging

### 5.2 Introduction

The power management unit is responsible for generating all required voltage supplies for the embedded MCU (VDDC, VDDP) and the external supply (VDDEXT). The power management unit is designed to ensure fail-safe behavior of the system IC by controlling all system modes including the corresponding transitions. Additionally, the PMU provides well defined sequences for the system mode transitions and generates hierarchical reset priorities. The reset priorities control the reset behavior of all system functionalities especially the reset behavior of the embedded MCU. All these functions are controlled by a state machine. The system master functionality of the PMU make use of an independent logic supply and system clock. For this reason, the PMU has an "Internal logic supply and system clock" module which works independently of the MCU clock.

### 5.2.1 Block Diagram

The following figure shows the structure of the Power Management Unit. **Table 4** describes the submodules in more detail.



**Figure 3 Power Management Unit Block Diagram**

**Table 4 Description of PMU Submodules**

| Mod. Name           | Modules  | Functions  |
|---------------------|--|--|
| Power Down Supply   | Independent supply voltage generation for PMU  | This supply is dedicated to the PMU to ensure an independent operation from generated power supplies (VDDP, VDDC).   |
| LP_CLK (= 18 MHz)   | - Clock source for all PMU submodules<br>- Backup clock source for System<br>- Clock source for WDT1 | This ultra low power oscillator generates the clock for the PMU.<br>This clock is also used as backup clock for the system in case of PLL Clock failure and as an independent clock source for WDT1. |
| LP_CLK2 (= 100 kHz) | Clock source for PMU   | This ultra low power oscillator generates the clock for the PMU in Stop Mode and in the cyclic modes.  |
| Peripherals         | Peripheral blocks of PMU   | These blocks include the analog peripherals to ensure a stable and fail-safe PMU startup and operation (bandgap, bias).  |

**Table 4 Description of PMU Submodules (cont'd)**

| <b>Mod. Name</b>                   | <b>Modules</b>   | <b>Functions</b>   |
|------------------------------------|--|--|
| Power Supply Generation Unit (PGU) | Voltage regulators for VDDP and VDDC                                   | This block includes the voltage regulators for the pad supply (VDDP) and the core supply (VDDC).   |
| VDDEXT                             | Voltage regulator for VDDEXT to supply external modules (e.g. sensors) | This voltage regulator is a dedicated supply for external modules and can also be used for cyclic sense operations (e.g. with hall sensor).  |
| PMU-SFR                            | All Extended Special Function registers that are relevant to the PMU.  | This module contains all registers needed to control and monitor the PMU.  |
| PMU-PCU                            | Power Control Unit of the PMU  | This block is responsible for controlling all power related actions within the PGU Module. It also contains all regulator related diagnostics such as undervoltage and overvoltage detection as well as overcurrent and short circuit diagnostics. |
| PMU-WMU                            | Wake-Up Management Unit of the PMU                                     | This block is responsible for controlling all wake-up related actions within the PMU Module.   |
| PMU-CMU                            | Cyclic Management Unit of the PMU                                      | This block is responsible for controlling all actions in cyclic mode.  |
| PMU-RMU                            | Reset Management Unit of the PMU                                       | This block generates resets triggered by the PMU such as undervoltage or short circuit reset, and passes all resets to the relevant modules and their register.  |

### 5.2.2 PMU Modes Overview

The following state diagram shows the available modes of the device.



Figure 4 Power Management Unit System Modes

### 5.3 Power Supply Generation Unit (PGU)

#### 5.3.1 Voltage Regulator 5.0V (VDDP)

This module represents the 5 V voltage regulator, which provides the pad supply for the parallel port pins and other 5 V analog functions (e.g. PWM Interface).

##### Features

- 5 V low-drop voltage regulator
- Overcurrent monitoring and shutdown with MCU signaling (interrupt)
- Overvoltage monitoring with MCU signaling (interrupt)
- Undervoltage monitoring with MCU signaling (interrupt)
- Undervoltage monitoring with reset (Undervoltage Reset,  $V_{DDPUV}$ )
- Pre-Regulator for VDDC Regulator
- GPIO Supply
- Pull Down Current Source at the output for Sleep Mode only (typ. 5 mA)

The output capacitor  $C_{VDDP}$  is mandatory to ensure proper regulator functionality.



Figure 5 Module Block Diagram of VDDP Voltage Regulator

### 5.3.2 Voltage Regulator 1.5V (VDDC)

This module represents the 1.5 V voltage regulator, which provides the supply for the microcontroller core, the digital peripherals and other internal analog 1.5 V functions (e.g. ADC2) of the chip. To further reduce the current consumption of the MCU during Stop Mode the output voltage can be lowered to 1.1 V.

#### Features

- 1.5 V low-drop voltage regulator
- Overcurrent monitoring and shutdown with MCU signaling (interrupt)
- Overvoltage monitoring with MCU signaling (interrupt)
- Undervoltage monitoring with MCU signaling (interrupt)
- Undervoltage monitoring with reset
- Pull Down Current Source at the output for Sleep Mode only (typ. 100  $\mu$ A)

The output capacitor  $C_{VDDC}$  is mandatory to ensure a proper regulator functionality.



Figure 6 Module Block Diagram of VDDC Voltage Regulator

### 5.3.3 External Voltage Regulator 5.0V (VDDEXT)

This module represents the 5 V voltage regulator, which serves as a supply for external circuits. It can be used e.g. to supply an external sensor, LEDs or potentiometers.

#### Features

- Switchable +5 V, low-drop voltage regulator
- Switch-on overcurrent blanking time in order to drive small capacitive loads
- Overcurrent monitoring and shutdown with MCU signaling (interrupt)
- Overvoltage monitoring with MCU signaling (interrupt)
- Undervoltage monitoring with MCU signaling (interrupt)
- Pull Down current source at the output for Sleep Mode only (typ. 100  $\mu$ A)
- Cyclic sense option together with GPIOs

The output capacitor  $C_{VDDEXT}$  is mandatory to ensure a proper regulator functionality.



Figure 7 Module Block Diagram of External Voltage Regulator



## 6 System Control Unit - Digital Modules (SCU-DM)

### 6.1 Features

- Flexible clock configuration features
- Reset management of all system resets
- System modes control for all power modes (active, power down, sleep)
- Interrupt enabling for many system peripherals
- General purpose input output control
- Debug mode control of system peripherals

### 6.2 Introduction

The System Control Unit (SCU) supports all central control tasks in the TLE9861QXA20. The SCU is made up of the following sub-modules:

- Clock System and Control
- Reset Control
- Power Management
- Interrupt Management
- General Port Control
- Flexible Peripheral Management
- Module Suspend Control
- Watchdog Timer
- Error Detection and Correction in Data Memory
- Miscellaneous Control

### 6.2.1 Block Diagram

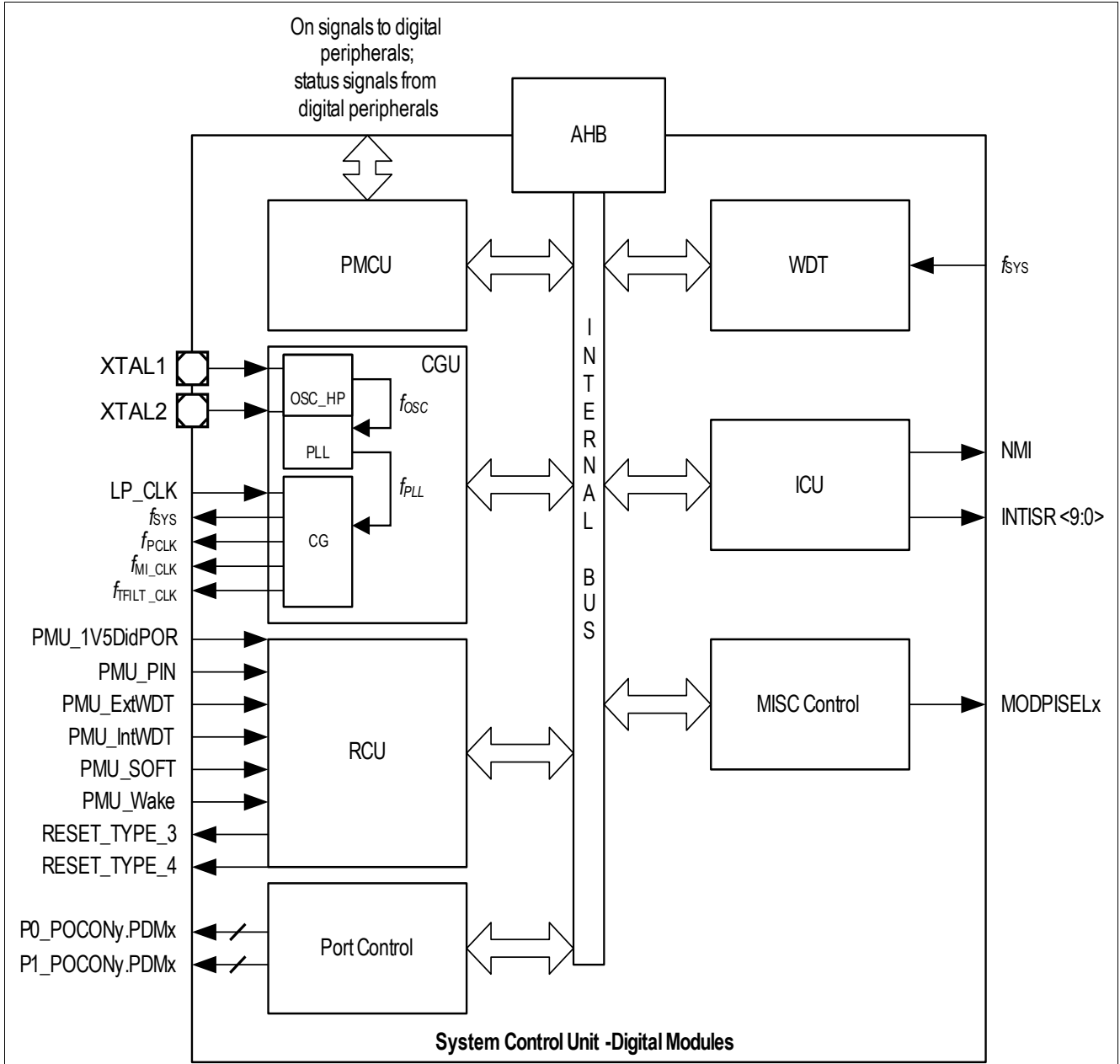

Figure 8 System Control Unit - Digital Modules Block Diagram

**AHB (Advanced High-Performance Bus)**

**PMCU (Power Module Control Unit)**

**WDT (Watchdog Timer in SCU-DM)**

- $f_{SYS}$  System clock

**CGU (Clock Generation Unit)**

- $f_{SYS}$  System clock
- $f_{PCLK}$  Peripheral clock

- $f_{MI\_CLK}$  Measurement interface clock
- $f_{TFILT\_CLK}$  Analog module filter clock
- LP\_CLK Clock source for all PMU submodules and WDT1

**ICU (Interrupt Control Unit)**

- NMI (Non-Maskable Interrupt)
- INTISR<15,13:4,1,0> External interrupt signals

**RCU (Reset Control Unit)**

- PMU\_1V5DidPOR Undervoltage reset of power down supply
- PMU\_PIN Reset generated by reset pin
- PMU\_ExtWDT WDT1 reset
- PMU\_IntWDT WDT (SCU) reset
- PMU\_SOFT Software reset
- PMU\_Wake Sleep Mode/Stop Mode exit with reset
- RESET\_TYPE\_3 Peripheral reset (contains all resets)
- RESET\_TYPE\_4 Peripheral reset (without SOFT and WDT reset)

**Port Control**

- P0\_POCONy.PDMx driver strength control
- P1\_POCONy.PDMx driver strength control

**MISC Control**

- MODPISELx Mode selection registers for UART (source section) and Timer (trigger or count selection)

### 6.3 Clock Generation Unit

The Clock Generation Unit (CGU) enables a flexible clock generation for TLE9861QXA20. During user program execution, the frequency can be modified to optimize the performance/power consumption ratio, allowing power consumption to be adapted to the actual application state.

The CGU in the TLE9861QXA20 consists of one oscillator circuit (OSC\_HP), a Phase-Locked Loop (PLL) module with an internal oscillator (OSC\_PLL), and a Clock Control Unit (CCU). The CGU can convert a low-frequency input/external clock signal to a high-frequency internal clock.

The system clock  $f_{SYS}$  is generated from of the following selectable clocks:

- PLL clock output  $f_{PLL}$
- Direct clock from oscillator OSC\_HP  $f_{OSC}$
- Low precision clock  $f_{LP\_CLK}$  (HW-enabled for startup after reset and during power-down wake-up sequence)



**Figure 9 Clock Generation Unit Block Diagram**

The following sections describe the different parts of the CGU.

### 6.3.1 Low Precision Clock

The clock source LP\_CLK is a low-precision RC oscillator (LP-OSC) with a nominal frequency of 18 MHz that is enabled by hardware as an independent clock source for the TLE9861QXA20 startup after reset and during the power-down wake-up sequence.  $f_{LP\_CLK}$  is not user configurable.

### 6.3.2 High Precision Oscillator Circuit (OSC\_HP)

The high precision oscillator circuit, designed to work with both an external crystal oscillator or an external stable clock source, consists of an inverting amplifier with XTAL1 as the input, and XTAL2 as the output.

**Figure 10** shows the recommended external circuitry for both operating modes, External Crystal Mode and External Input Clock Mode.

#### 6.3.2.1 External Input Clock Mode

When supplying the clock signal directly, not using an external crystal and bypassing the oscillator, the input frequency needs to be equal or greater than 4 MHz if the PLL VCO part is used.

When using an external clock signal it must be connected to XTAL1. XTAL2 is left open (unconnected).

#### 6.3.2.2 External Crystal Mode

When using an external crystal, its frequency can be within the range of 4 MHz to 25 MHz. An external oscillator load circuitry must be used, connected to both pins, XTAL1 and XTAL2. It normally consists of the two load capacitances C1 and C2. A series damping resistor could be required for some crystals. The exact values and the corresponding operating ranges depend on the crystal and have to be determined and optimized in cooperation with the crystal vendor using the negative resistance method. The following load cap values can be used as starting point for the evaluation:

**Table 5 External CAP Capacitors**

| Fundamental Mode Crystal Frequency (approx., MHz) | Load Caps $C_1, C_2$ (pF) |
|---|---------------------------|
| 4   | 33                        |
| 8   | 18                        |
| 12  | 12                        |
| 16  | 10                        |
| 20  | 10                        |
| 25  | 8                         |



**Figure 10 TLE9861QXA20 External Circuitry for the OSC\_HP**

## 7 System Control Unit - Power Modules (SCU-PM)

### 7.1 Features

- Clock Watchdog Unit (CWU): supervision of all clocks with NMI signaling relevant to power modules
- Interrupt Control Unit (ICU): all interrupt flags and status flags with system relevance
- Power Control Unit (PCU): takes over control when device enters and exits Sleep and Stop Mode
- External Watchdog (WDT1): independent system watchdog for monitoring system activity

### 7.2 Introduction

#### 7.2.1 Block Diagram

The System Control Unit of the power modules consists of the sub-modules in the figure shown below:



Figure 11 Block diagram of System Control Unit - Power Modules

**AHB (Advanced High-Performance Bus)**

**CWU (Clock Watchdog Unit)**

- $f_{sys}$  system frequency: PLL output
- MI\_CLK measurement interface clock (analog clock): derived from  $f_{sys}$  using division factors 1/2/3/4
- TFILT\_CLK clock used for digital filters: derived from  $f_{sys}$  using configurable division factors

**WDT1 (System Watchdog)**

- LP\_CLK clock source for all PMU submodules and WDT1

**ICU (Interrupt Control Unit)**

- PREWARN\_SUP\_NMI supply prewarning NMI request
- PREWARN\_SUP\_INT supply prewarning interrupt
- grouping of peripheral interrupts for external interrupt nodes:
  - grouping single peripheral interrupts for interrupt node INT<2> (Measurement Unit (MU))
  - grouping single peripheral interrupts for interrupt node INT<3> (ADC1-VAREF)
  - grouping single peripheral interrupts for interrupt node INT<10> (UART1-PWM Interface)
  - grouping single peripheral interrupts for interrupt node INT<14> (Bridge Driver)

## 8 ARM Cortex-M3 Core

### 8.1 Features

The key features of the Cortex-M3 implemented are listed below.

#### **Processor Core; a low gate count core, with low latency interrupt processing:**

- A subset of the Thumb<sup>®</sup>-2 Instruction Set
- Banked stack pointer (SP) only
- 32-bit hardware divide instructions, SDIV and UDIV (Thumb-2 instructions)
- Handler and Thread Modes
- Thumb and debug states
- Interruptible-continued instructions LDM/STM, Push/Pop for low interrupt latency
- Automatic processor state saving and restoration for low latency Interrupt Service Routine (ISR) entry and exit
- ARM architecture v7-M Style BE8/LE support
- ARMv6 unaligned accesses

#### **Nested Vectored Interrupt Controller (NVIC) closely integrated with the processor core to achieve low latency interrupt processing:**

- Interrupts, configurable from 1 to 16
- Bits of priority (4)
- Dynamic reprioritization of interrupts
- Priority grouping. This enables selection of preemptive interrupt levels and non-preemptive interrupt levels
- Support for tail-chaining and late arrival of interrupts. This enables back-to-back interrupt processing without the overhead of state saving and restoration between interrupts.
- Processor state automatically saved on interrupt entry, and restored on interrupt exit, with no instruction overhead

#### **Bus interfaces**

- Advanced High-performance Bus-Lite (AHB-Lite) interfaces: ICode, DCode, and System bus interface
- Memory access alignment
- Write buffer for buffering of write data



## 8.2 Introduction

The ARM Cortex-M3 processor is a leading 32-bit processor and provides a high-performance and cost-optimized platform for a broad range of applications including microcontrollers, automotive body systems and industrial control systems. Like the other Cortex family processors, the Cortex-M3 processor implements the Thumb®-2 instruction set architecture. With the optimized feature set the Cortex-M3 delivers 32-bit performance in an application space that is usually associated with 8- and 16-bit microcontrollers.

### 8.2.1 Block Diagram

Figure 12 shows the functional blocks of the Cortex-M3.



Figure 12 Cortex-M3 Block Diagram

## 9 DMA Controller

**Figure 13** shows the Top Level Block Diagram of the TLE9861QXA20.

The bus matrix allows the  $\mu$ DMA to access the PBA0, PBA1 and RAM.

### 9.1 Features

The principal features of the DMA Controller are that:

- it is compatible with AHB-Lite for the DMA transfers
- it is compatible with APB for programming the registers
- it has a single AHB-Lite master for transferring data using a 32-bit address bus and 32-bit data bus
- it supports 13 DMA channels
- each DMA channel has dedicated handshake signals
- each DMA channel has a programmable priority level
- each priority level arbitrates using a fixed priority that is determined by the DMA channel number. The DMA also supports multiple transfer types:
  - memory-to-memory
  - memory-to-peripheral
  - peripheral-to-memory
- it supports multiple DMA cycle types
- it supports multiple DMA transfer data widths
- each DMA channel can access a primary, and alternate, channel control data structure
- all the channel control data is stored in system memory (RAM) in little-endian format
- it performs all DMA transfers using the single AHB-Lite burst type. The destination data width is equal to the source data width.
- the number of transfers in a single DMA cycle can be programmed from 1 to 1024
- the transfer address increment can be greater than the data width

## 9.2 Introduction

Please also refer to [Chapter 9.3, Functional Description](#).

### 9.2.1 Block Diagram



Figure 13 DMA Controller Top Level Block Diagram

## 9.3 Functional Description

### 9.3.1 DMA Mode Overview

The DMA controller implements the following 13 hardware DMA requests:

- ADC1 complete sequence 1 done: DMA transfer is requested on completion of the ADC1 channel conversion sequence.
- ADC1 exceptional sequence 2 (ESM) done: DMA transfer is requested on completion of the ADC1 conversion sequence triggered by an exceptional measurement request.
- SSC1/2 transmit byte: DMA transfer is requested upon the completion of data transmission via SSC1/2
- SSC1/2: receive byte: DMA transfer is requested upon the completion of data reception via SSC1/2.
- ADC1 channel 0 conversion done: DMA transfer is requested on completion of the ADC1 channel 0 conversion.
- ADC1 channel 1 conversion done: DMA transfer is requested on completion of the ADC1 channel 1 conversion.
- ADC1 channel 2 conversion done: DMA transfer is requested on completion of the ADC1 channel 2 conversion.
- ADC1 channel 3 conversion done: DMA transfer is requested on completion of the ADC1 channel 3 conversion.
- ADC1 channel 4 conversion done: DMA transfer is requested on completion of the ADC1 channel 4 conversion.
- ADC1 channel 5 conversion done: DMA transfer is requested on completion of the ADC1 channel 5 conversion.
- ADC1 channel 6 conversion done: DMA transfer is requested on completion of the ADC1 channel 6 conversion.
- ADC1 channel 7 conversion done: DMA transfer is requested on completion of the ADC1 channel 7 conversion.
- Timer3 ccu6\_int: DMA transfer is requested following a timer trigger.

## 10 Address Space Organization

The TLE9861QXA20 manipulates operands in the following memory spaces:

- 36 KByte of Flash memory in code space
- 32 KByte Boot ROM memory in code space (used for boot code and IP storage)
- 3 KByte RAM memory in code space and data space (RAM can be read/written as program memory or external data memory)
- Special function registers (SFRs) in peripheral space

The figure below shows the detailed address alignment of TLE9861QXA20:

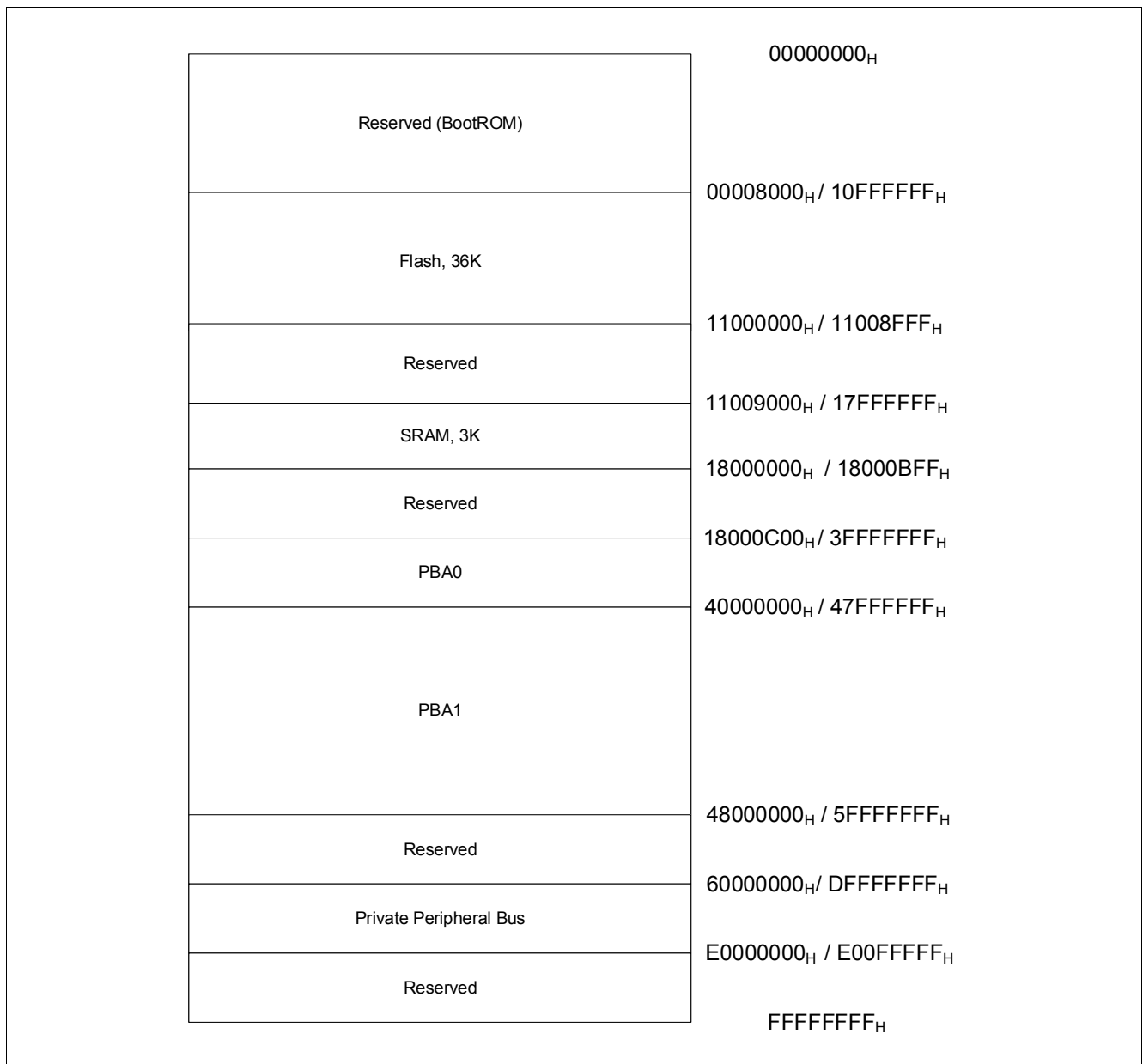

Figure 14 TLE9861QXA20 Memory Map

## 11 Memory Control Unit

### 11.1 Features

- Handles all system memories and their interaction with the CPU
- Memory protection functions for all system memories (D-Flash, P-Flash, RAM)
- Address management with access violation detection including reporting
- Linear address range for all memories (no paging)

### 11.2 Introduction

#### 11.2.1 Block Diagram

The Memory Control Unit (MCU) is divided in the following sub-modules:

- NVM memory module (embedded Flash Memory)
- RAM memory module
- BootROM memory module
- Memory Protection Unit (MPU) module
- Peripheral Bridge PBA0

Memory Control Unit

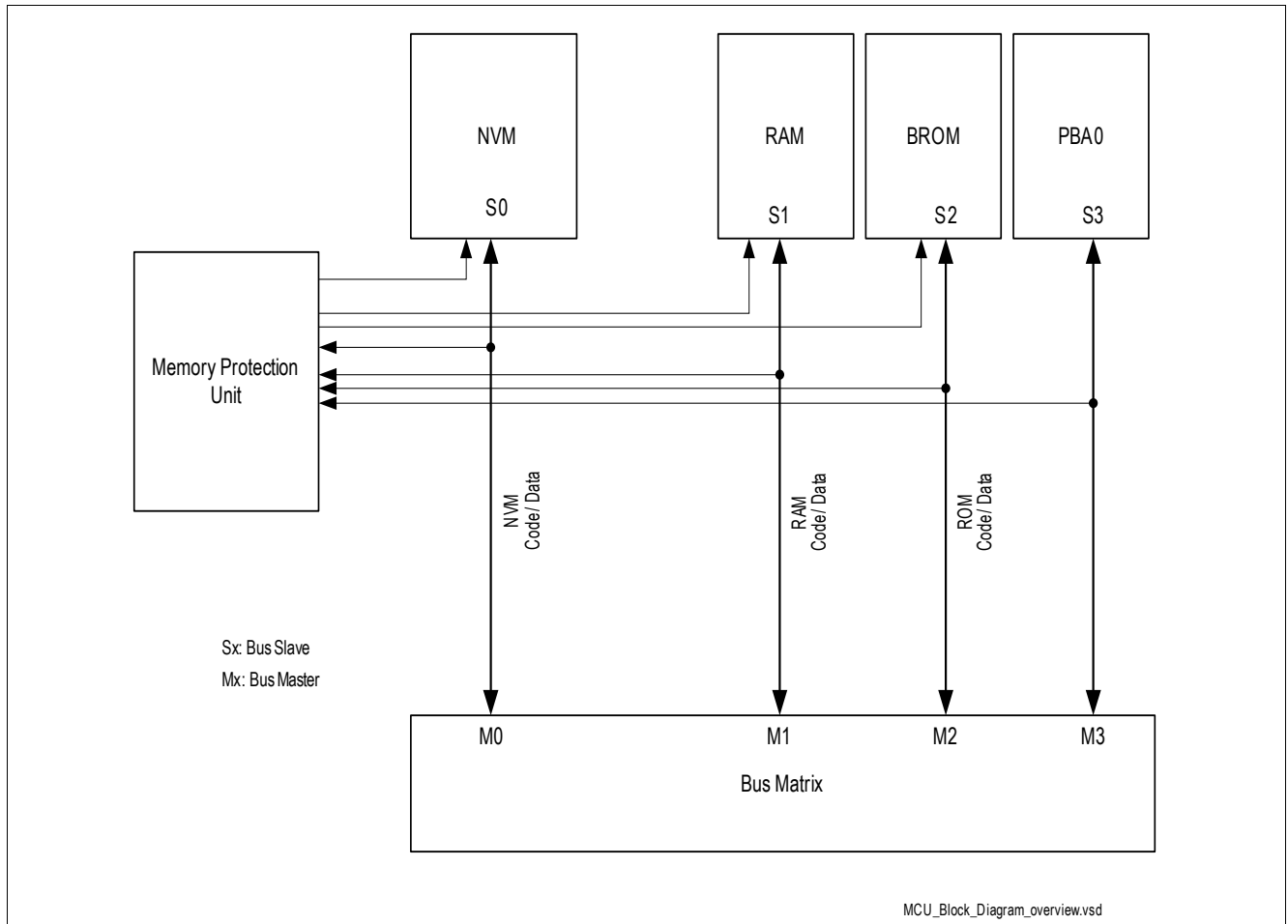

Figure 15 MCU Block View

### 11.3 NVM Module (Flash Memory)

The Flash Memory provides an embedded user-programmable non-volatile memory, allowing fast and reliable storage of user code and data.

#### Features

- In-system programming via PWM Interface (Flash Mode) and SWD
- Error Correction Code (ECC) for detection of single-bit and double-bit errors and dynamic correction of single Bit errors.
- Interrupts and signals double-bit error by NMI
- Program width of 128 byte (page)
- Minimum erase width of 128 bytes (page)
- Integrated hardware support for EEPROM emulation
- 8 byte read access
- Physical read access time: 75 ns
- Code read access acceleration integrated; read buffer and automatic pre-fetch
- Page program time: 3 ms
- Page erase (128 bytes) and sector erase (4K bytes) time: 4ms

*Note: The user has to ensure that no flash operations which change the content of the flash get interrupted at any time.*

The clock for the NVM is supplied with the system frequency  $f_{sys}$ . Integrated firmware routines are provided to erase NVM, and other operations including EEPROM emulation are provided as well.



## 12 Interrupt System

### 12.1 Features

- Up to 16 interrupt nodes for on-chip peripherals
- Up to 8 NMI nodes for critical system events
- Maximum flexibility for all 16 interrupt nodes

### 12.2 Introduction

Before enabling an interrupt, all corresponding interrupt status flags should be cleared.

#### 12.2.1 Overview

The TLE9861QXA20 supports 16 interrupt vectors with 16 priority levels. Fifteen of these interrupt vectors are assigned to the on-chip peripherals: GPT12, SSC, CCU6, DMA, Bridge Driver and A/D Converter are each assigned to one dedicated interrupt vector; while UART1 and Timer2 or UART2, External Interrupt 2 and Timer21 share interrupt vectors. Two vectors are dedicated for External Interrupt 0 and 1.

**Table 6 Interrupt Vector Table**

| Service Request | Node ID | Description  |
|-----------------|---------|--|
| GPT12           | 0/1     | GPT interrupt (T2-T6, CAPIN)   |
| MU- ADC8/T3     | 2       | Measurement Unit, VBG, Timer3  |
| ADC1            | 3       | ADC1 interrupt / VREF5V Overload / VREF5V OV/UV, 10-bit ADC              |
| CCU0            | 4       | CCU6 node 0 interrupt  |
| CCU1            | 5       | CCU6 node 1 interrupt  |
| CCU2            | 6       | CCU6 node 2 interrupt  |
| CCU3            | 7       | CCU6 node 3 interrupt  |
| SSC1            | 8       | SSC1 interrupt (receive, transmit, error)                                |
| SSC2            | 9       | SSC2 interrupt (receive, transmit, error)                                |
| UART1           | 10      | UART1 interrupt (receive, transmit), Timer2, PWM-Interface               |
| UART2           | 11      | UART2 interrupt (receive, transmit), Timer21, External interrupt (EINT2) |
| EXINT0          | 12      | External interrupt (EINT0), MON  |
| EXINT1          | 13      | External interrupt (EINT1)   |
| BDRV/CP         | 14      | Bridge Driver / Charge Pump  |
| DMA             | 15      | DMA Controller   |

**Table 7 NMI Interrupt Table**

| Service Request            | Node | Description             |
|----------------------------|------|-------------------------|
| Watchdog Timer NMI         | NMI  | Watchdog Timer overflow |
| PLL NMI                    | NMI  | PLL Loss-of-Lock        |
| NVM Operation Complete NMI | NMI  | NVM Operation Complete  |
| Overtemperature NMI        | NMI  | System Overtemperature  |

**Table 7 NMI Interrupt Table**

| <b>Service Request</b>  | <b>Node</b> | <b>Description</b>                                   |
|-------------------------|-------------|--|
| Oscillator Watchdog NMI | NMI         | Oscillator Watchdog / MI_CLK Watchdog Timer Overflow |
| NVM Map Error NMI       | NMI         | NVM Map Error  |
| ECC Error NMI           | NMI         | RAM / NVM Uncorrectable ECC Error                    |
| Supply Prewarning NMI   | NMI         | Supply Prewarning                                    |

## 13 Watchdog Timer (WDT1)

### 13.1 Features

There are two watchdog timers in the system. The Watchdog Timer (WDT) within the System Control Unit - Digital Modules (see SCU\_DM) and the Watchdog Timer (WDT1) located within the System Control Unit - Power Modules (see SCU\_PM). The Watchdog Timer WDT1 is described in this section.

In Active Mode, the WDT1 acts as a windowed watchdog timer, which provides a highly reliable and safe way to recover from software or hardware failures.

The WDT1 is always enabled in Active Mode. In Sleep Mode, Low Power Mode and SWD Mode the WDT1 is automatically disabled.

#### Functional Features

- Windowed Watchdog Timer with programmable timing in Active Mode
- Long open window (typ. 80ms) after power-up, reset, wake-up
- Short open window (typ. 30ms) to facilitate Flash programming
- Disabled during debugging
- Safety shutdown to Sleep Mode after 5 missed WDT1 services

### 13.2 Introduction

The behavior of the Watchdog Timer in Active Mode is illustrated in [Figure 16](#).

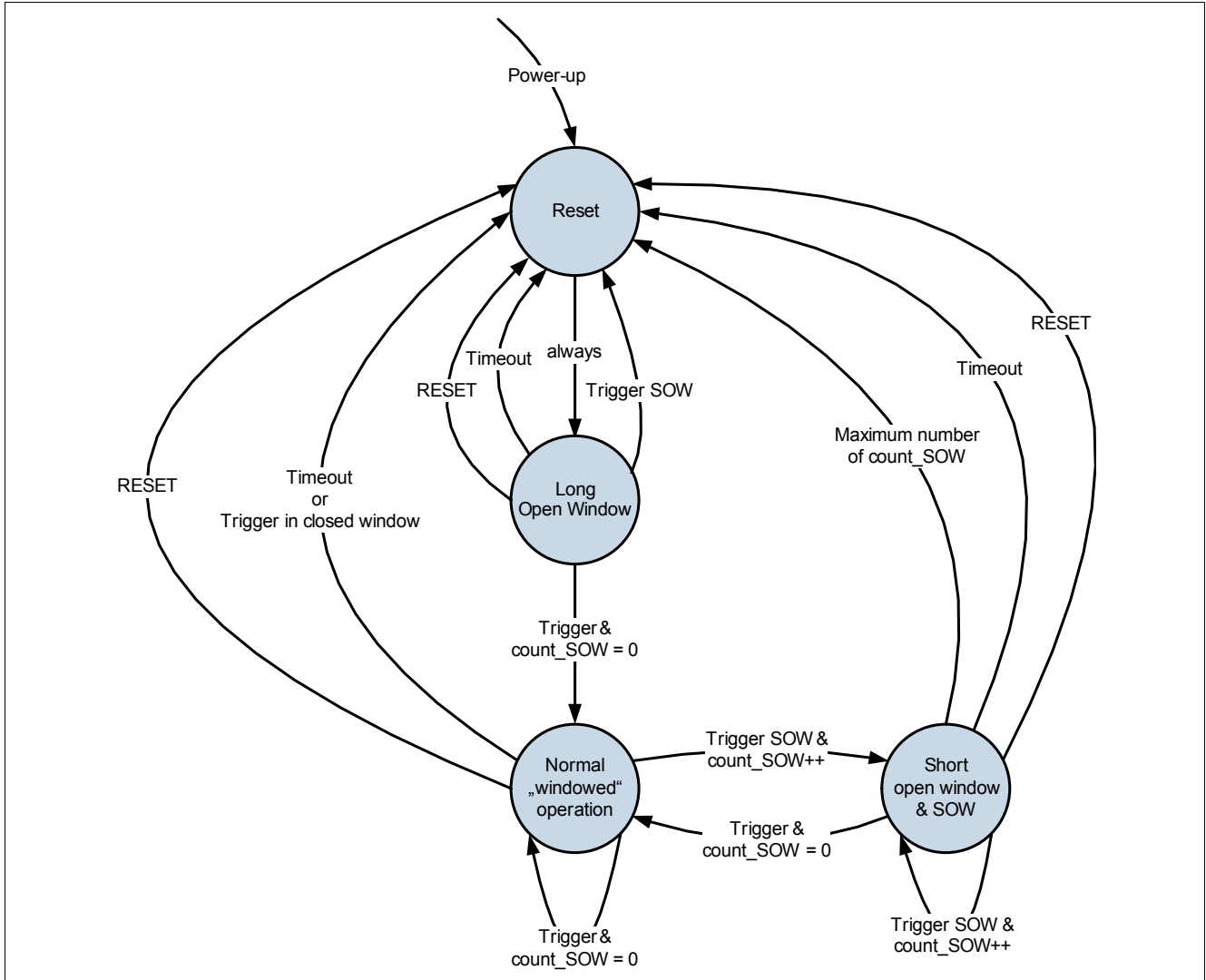

Figure 16 Watchdog Timer Behavior

## 14 GPIO Ports and Peripheral I/O

The TLE9861QXA20 has 15 port pins organized into three parallel ports: Port 0 (P0), Port 1 (P1) and Port 2 (P2). Each port pin has a pair of internal pull-up and pull-down devices that can be individually enabled or disabled. P0 and P1 are bidirectional and can be used as general purpose input/output (GPIO) or to perform alternate input/output functions for the on-chip peripherals. When configured as an output, the open drain mode can be selected. On Port 2 (P2) analog inputs are shared with general purpose input.

### 14.1 Features

#### Bidirectional Port Features (P0, P1)

- Configurable pin direction
- Configurable pull-up/pull-down devices
- Configurable open drain mode
- Configurable drive strength
- Transfer of data through digital inputs and outputs (general purpose I/O)
- Alternate input/output for on-chip peripherals

#### Analog Port Features (P2)

- Configurable pull-up/pull-down devices
- Transfer of data through digital inputs
- Alternate inputs for on-chip peripherals

### 14.2 Introduction

#### 14.2.1 Port 0 and Port 1

**Figure 17** shows the block diagram of an TLE9861QXA20 bidirectional port pin. Each port pin is equipped with a number of control and data bits, thus enabling very flexible usage of the pin. By defining the contents of the control register, each individual pin can be configured as an input or an output. The user can also configure each pin as an open drain pin with or without internal pull-up/pull-down device.

Each bidirectional port pin can be configured for input or output operation. Switching between input and output mode is accomplished through the register `Px_DIR` ( $x = 0$  or  $1$ ), which enables or disables the output and input drivers. A port pin can only be configured as either input or output mode at any one time.

In input mode (default after reset), the output driver is switched off (high-impedance). The voltage level present at the port pin is translated into a logic 0 or 1 via a Schmitt trigger device and can be read via the register `Px_DATA`.

In output mode, the output driver is activated and drives the value supplied through the multiplexer to the port pin. In the output driver, each port line can be switched to open drain mode or normal mode (push-pull mode) via the register `Px_OD`.

The output multiplexer in front of the output driver enables the port output function to be used for different purposes. If the pin is used for general purpose output, the multiplexer is switched by software to the data register `Px_DATA`. Software can set or clear the bit in `Px_DATA` and therefore directly influence the state of the port pin. If an on-chip peripheral uses the pin for output signals, alternate output lines (AltDataOut) can be switched via the multiplexer to the output driver circuitry. Selection of the alternate output function is defined in registers `Px_ALTSEL0` and `Px_ALTSEL1`. When a port pin is used as an alternate function, its direction must be set accordingly in the register `Px_DIR`.

Each pin can also be programmed to activate an internal weak pull-up or pull-down device. Register Px\_PUDESEL selects whether a pull-up or the pull-down device is activated while register Px\_PUDEN enables or disables the pull device.



Figure 17 General Structure of Bidirectional Port (P0, P1)

### 14.2.2 Port 2

**Figure 18** shows the structure of an input-only port pin. Each P2 pin can only function in input mode. Register P2\_DIR is provided to enable or disable the input driver. When the input driver is enabled, the actual voltage level present at the port pin is translated into a logic 0 or 1 via a Schmitt trigger device and can be read via register P2\_DATA. Each pin can also be programmed to activate an internal weak pull-up or pull-down device. Register P2\_PUDSEL selects whether a pull-up or the pull-down device is activated while register P2\_PUDEN enables or disables the pull device. The analog input (AnalogIn) bypasses the digital circuitry and Schmitt trigger device for direct feed-through to the ADC input channels.



**Figure 18** General Structure of Input Port (P2)

## 14.3 TLE9861QXA20 Port Module

### 14.3.1 Port 0

#### 14.3.1.1 Port 0 Functions

**Table 8 Port 0 Input/Output Functions**

| Port Pin | Input/Output | Select | Connected Signal(s) | From/to Module  |
|----------|--------------|--------|---------------------|-----------------|
| P0.0     | Input        | GPI    | P0_DATA.P0          |                 |
|          |              | INP1   | SWCLK / TCK_0       | SW              |
|          |              | INP2   | T12HR_0             | CCU6            |
|          |              | INP3   | T4INA               | GPT12T4         |
|          |              | INP4   | T2_0                | Timer 2         |
|          |              | INP5   | –                   | –               |
|          |              | INP6   | EXINT2_3            | SCU             |
|          | Output       | GPO    | P0_DATA.P0          |                 |
|          |              | ALT1   | T3OUT               | GPT12T3         |
|          |              | ALT2   | EXF21_0             | Timer 21        |
|          |              | ALT3   | RXDO_2              | UART2           |
| P0.1     | Input        | GPI    | P0_DATA.P1          |                 |
|          |              | INP2   | T13HR_0             | CCU6            |
|          |              | INP3   | TxD1                | PWM_TxD         |
|          |              | INP4   | CAPINA              | GPT12CAP        |
|          |              | INP5   | T21_0               | Timer 21        |
|          |              | INP6   | T4INC               | GPT12T4         |
|          |              | INP7   | MRST_1_2            | SSC1            |
|          |              | INP8   | EXINT0_2            | SCU             |
|          | Output       | GPO    | P0_DATA.P1          |                 |
|          |              | ALT1   | TxD1                | UART1 / PWM_TxD |
|          |              | ALT2   | –                   | –               |
|          |              | ALT3   | T6OUT               | GPT12T6         |



**Table 8 Port 0 Input/Output Functions (cont'd)**

| Port Pin | Input/Output | Select | Connected Signal(s) | From/to Module |
|----------|--------------|--------|---------------------|----------------|
| P0.2     | Input        | GPI    | P0_DATA.P2          |                |
|          |              | INP1   | CCPOS2_1            | CCU6           |
|          |              | INP2   | T2EUDA              | GPT12T2        |
|          |              | INP3   | MTSR_1              | SSC1           |
|          |              | INP4   | T21EX_0             | Timer 21       |
|          |              | INP5   | T6INA               | GPT12T6        |
|          | Output       | GPO    | P0_DATA.P2          | –              |
|          |              | ALT1   | COU60_0             | CCU6           |
|          |              | ALT2   | MTSR_1              | SSC1           |
|          |              | ALT3   | EXF2_0              | Timer 2        |
| P0.3     | Input        | GPI    | P0_DATA.P3          |                |
|          |              | INP1   | SCK_1               | SSC1           |
|          |              | INP2   | CAPINB              | GPT12          |
|          |              | INP3   | T5INA               | GPT12T5        |
|          |              | INP4   | T4EUDA              | GPT12T4        |
|          |              | INP5   | CCPOS0_1            | CCU6           |
|          | Output       | GPO    | P0_DATA.P3          |                |
|          |              | ALT1   | SCK_1               | SSC1           |
|          |              | ALT2   | EXF21_2             | Timer 21       |
|          |              | ALT3   | T6OUT               | GPT12T6        |
| P0.4     | Input        | GPI    | P0_DATA.P4          |                |
|          |              | INP1   | MRST_1_0            | SSC1           |
|          |              | INP2   | CC60_0              | CCU6           |
|          |              | INP3   | T21_2               | Timer 21       |
|          |              | INP4   | EXINT2_2            | SCU            |
|          |              | INP5   | T3EUDA              | GPT12T3        |
|          |              | INP6   | CCPOS1_1            | CCU6           |
|          | Output       | GPO    | P0_DATA.P4          |                |
|          |              | ALT1   | MRST_1_0            | SSC1           |
|          |              | ALT2   | CC60_0              | CCU6           |
|          |              | ALT3   | CLKOUT_0            | SCU            |

### 14.3.2 Port 1

#### 14.3.2.1 Port 1 Functions

**Table 9 Port 1 Input / Output Functions**

| Port Pin | Input/Output | Select   | Connected Signal(s) | From/to Module |
|----------|--------------|----------|---------------------|----------------|
| P1.0     | Input        | GPI      | P1_DATA.P0          |                |
|          |              | INP1     | T3INC               | GPT12T3        |
|          |              | INP2     | T4EUIDB             | GPT12T4        |
|          |              | INP3     | CC61_0              | CCU6           |
|          |              | INP4     | SCK_2               | SSC2           |
|          | INP5         | EXINT1_2 | SCU                 |                |
|          | Output       | GPO      | P1_DATA.P0          |                |
|          |              | ALT1     | SCK_2               | SSC2           |
|          |              | ALT2     | CC61_0              | CCU6           |
|          |              | ALT3     | EXF21_3             | Timer 21       |
| P1.1     | Input        | GPI      | P1_DATA.P1          |                |
|          |              | INP1     | –                   | –              |
|          |              | INP2     | T6EUDA              | GPT12T6        |
|          |              | INP3     | –                   | –              |
|          |              | INP4     | MTSR_2              | SSC2           |
|          |              | INP5     | T21_1               | Timer 21       |
|          | INP6         | EXINT1_0 | SCU                 |                |
|          | Output       | GPO      | P1_DATA.P1          | –              |
|          |              | ALT1     | MTSR_2              | SSC2           |
|          |              | ALT2     | COU61_0             | CCU6           |
| ALT3     |              | TXD2_0   | UART2               |                |
| P1.2     | Input        | GPI      | P1_DATA.P2          |                |
|          |              | INP1     | T2INA               | GPT12T2        |
|          |              | INP2     | T2EX_1              | Timer 2        |
|          |              | INP3     | T21EX_3             | Timer 21       |
|          |              | INP4     | MRST_2_0            | SSC2           |
|          |              | INP5     | RXD2_0              | UART2          |
|          |              | INP6     | CCPOS2_2            | CCU6           |
|          | INP7         | EXINT0_1 | SCU                 |                |
|          | Output       | GPO      | P1_DATA.P2          |                |
|          |              | ALT1     | MRST_2_0            | SSC2           |
|          |              | ALT2     | COU63_0             | CCU6           |
| ALT3     |              | T3OUT    | GPT12T3             |                |

**Table 9 Port 1 Input / Output Functions (cont'd)**

| Port Pin | Input/Output | Select     | Connected Signal(s) | From/to Module |            |     |
|----------|--------------|------------|---------------------|----------------|------------|-----|
| P1.3     | Input        | GPI        | P1_DATA.P3          |                |            |     |
|          |              | INP1       | T6INB               | GPT12T6        |            |     |
|          |              | INP2       | –                   |                |            |     |
|          |              | INP3       | CC62_0              | CCU6           |            |     |
|          |              | INP4       | T6EUIDB             | GPT12T6        |            |     |
|          |              | INP5       | –                   |                |            |     |
|          |              | INP6       | CCPOS0_2            | CCU6           |            |     |
|          |              | INP7       | EXINT1_1            | SCU            |            |     |
|          | Output       | GPO        | P1_DATA.P3          |                |            |     |
|          |              | ALT1       | EXF21_1             | Timer 21       |            |     |
|          |              | ALT2       | CC62_0              | CCU6           |            |     |
|          |              | ALT3       | TXD2_1              | UART2          |            |     |
|          |              | P1.4       | Input               | GPI            | P1_DATA.P4 |     |
|          |              |            |                     | INP1           | EXINT2_1   | SCU |
| INP2     | T21EX_1      |            |                     | Timer 21       |            |     |
| INP3     | T5EUDA       |            |                     | GPT12T5        |            |     |
| INP4     | RxD1         |            |                     | UART1          |            |     |
| INP5     | T2INB        |            |                     | GPT12T2        |            |     |
| INP6     | CCPOS1_2     |            |                     | CCU6           |            |     |
| INP7     | MRST_1_3     |            |                     | SSC1           |            |     |
| Output   | GPO          | P1_DATA.P4 |                     |                |            |     |
|          | ALT1         | CLKOUT_1   | SCU                 |                |            |     |
|          | ALT2         | COU62_0    | CCU6                |                |            |     |
|          | ALT3         | RxD1       | UART1 / PWM_RxD     |                |            |     |

### 14.3.3 Port 2

#### 14.3.3.1 Port 2 Functions

**Table 10 Port 2 Input Functions**

| Port Pin | Input/Output | Select | Connected Signal(s) | From/to Module |
|----------|--------------|--------|---------------------|----------------|
| P2.0     | Input        | GPI    | P2_DATA.P0          |                |
|          |              | INP1   | CCPOS0_3            | CCU6           |
|          |              | INP2   | -                   | -              |
|          |              | INP3   | T12HR_2             | CCU6           |
|          |              | INP4   | EXINT0_0            | SCU            |
|          |              | INP5   | CC61_2              | CCU6           |
|          |              | ANALOG | AN0                 | ADC            |
|          |              |        | XTAL (in)           | XTAL           |
| P2.2     | Input        | GPI    | P2_DATA.P2          |                |
|          |              | INP1   | CCPOS2_3            | CCU6           |
|          |              | INP2   | T13HR_2             | CCU6           |
|          |              | INP3   | -                   |                |
|          |              | INP4   | CC62_2              | CCU6           |
|          |              | ANALOG | AN2                 | ADC            |
|          |              | OUT    | XTAL (out)          | XTAL           |
|          |              |        |                     |                |
| P2.3     | Input        | GPI    | P2_DATA.P3          |                |
|          |              | INP1   | CCPOS1_0            | CCU6           |
|          |              | INP2   | CTRAP#_1            | CCU6           |
|          |              | INP3   | T21EX_2             | Timer 21       |
|          |              | INP4   | CC60_1              | CCU6           |
|          |              | INP5   | EXINT0_3            | SCU            |
|          |              | ANALOG | AN3                 | ADC            |
|          |              |        |                     |                |
| P2.4     | Input        | GPI    | P2_DATA.P4          |                |
|          |              | INP1   | CTRAP#_0            | CCU6           |
|          |              | INP2   | T2EUDB              | GPT12T2        |
|          |              | INP3   | MRST_1_1            | SSC1           |
|          |              | INP4   | EXINT1_3            | SCU            |
|          |              | ANALOG | AN4                 | ADC            |
| P2.5     | Input        | GPI    | P2_DATA.P5          |                |
|          |              | INP1   | RXD2_1              | UART2          |
|          |              | INP2   | T3EUDB              | GPT12T3        |
|          |              | INP3   | MRST_2_1            | SSC2           |
|          |              | INP4   | T2_1                | Timer 2        |
|          |              | ANALOG | AN5                 | ADC            |

## 15 General Purpose Timer Units (GPT12)

### 15.1 Features

#### 15.1.1 Features Block GPT1

The following list summarizes the supported features:

- $f_{\text{GPT}}/4$  maximum resolution
- 3 independent timers/counters
- Timers/counters can be concatenated
- 4 operating modes:
  - Timer Mode
  - Gated Timer Mode
  - Counter Mode
  - Incremental Interface Mode
- Reload and Capture functionality
- Shared interrupt: Node 0

#### 15.1.2 Features Block GPT2

The following list summarizes the supported features:

- $f_{\text{GPT}}/2$  maximum resolution
- 2 independent timers/counters
- Timers/counters can be concatenated
- 3 operating modes:
  - Timer Mode
  - Gated Timer Mode
  - Counter Mode
- Extended capture/reload functions via 16-bit capture/reload register CAPREL
- Shared interrupt: Node 1

### 15.2 Introduction

The General Purpose Timer Unit blocks GPT1 and GPT2 have very flexible multifunctional timer structures which may be used for timing, event counting, pulse width measurement, pulse generation, frequency multiplication, and other purposes.

They incorporate five 16-bit timers that are grouped into the two timer blocks GPT1 and GPT2. Each timer in each block may operate independently in a number of different modes such as Gated timer or Counter Mode, or may be concatenated with another timer of the same block.

Each block has alternate input/output functions and specific interrupts associated with it. Input signals can be selected from several sources by register PISEL.

The GPT module is clocked with clock  $f_{\text{GPT}}$ .  $f_{\text{GPT}}$  is a clock derived from  $f_{\text{SYS}}$ .

### 15.2.1 Block Diagram GPT1

**Block GPT1** contains three timers/counters: The core timer T3 and the two auxiliary timers T2 and T4. The maximum resolution is  $f_{GPT}/4$ . The auxiliary timers of GPT1 may optionally be configured as reload or capture registers for the core timer.



Figure 19 GPT1 Block Diagram (n = 2 ... 5)

### 15.2.2 Block Diagram GPT2

**Block GPT2** contains two timers/counters: The core timer T6 and the auxiliary timer T5. The maximum resolution is  $f_{GPT}/2$ . An additional Capture/Reload register (CAPREL) supports capture and reload operation with extended functionality.



Figure 20 GPT2 Block Diagram (n = 1 ... 4)

## 16 Timer2 and Timer21

### 16.1 Features

- 16-bit auto-reload mode
  - selectable up or down counting
- One channel 16-bit capture mode

### 16.2 Introduction

The timer modules are general-purpose 16-bit timers. Timer 2/21 can function as a timer or counter in each of its modes. As a timer, it counts with an input clock of  $f_{PCLK}/12$  (if prescaler is disabled). As a counter, Timer 2 counts 1-to-0 transitions on pin T2. In the counter mode, the maximum resolution for the count is  $f_{PCLK}/24$  (if prescaler is disabled).

#### 16.2.1 Timer2 and Timer21 Modes Overview

Table 11 Timer2 and Timer21 Modes

| Mode            | Description   |
|-----------------|---|
| Auto-reload     | <b>Up/Down Count Disabled</b> <ul style="list-style-type: none"> <li>• Count up only</li> <li>• Start counting from 16-bit reload value, overflow at <math>FFFF_H</math></li> <li>• Reload event configurable for trigger by overflow condition only, or by negative/positive edge at input pin T2EX as well</li> <li>• Programmable reload value in register RC2</li> <li>• Interrupt is generated with reload events.</li> </ul>  |
| Auto-reload     | <b>Up/Down Count Enabled</b> <ul style="list-style-type: none"> <li>• Count up or down, direction determined by level at input pin T2EX</li> <li>• No interrupt is generated</li> <li>• Count up               <ul style="list-style-type: none"> <li>– Start counting from 16-bit reload value, overflow at <math>FFFF_H</math></li> <li>– Reload event triggered by overflow condition</li> <li>– Programmable reload value in register RC2</li> </ul> </li> <li>• Count down               <ul style="list-style-type: none"> <li>– Start counting from <math>FFFF_H</math>, underflow at value defined in register RC2</li> <li>– Reload event triggered by underflow condition</li> <li>– Reload value fixed at <math>FFFF_H</math></li> </ul> </li> </ul> |
| Channel capture | <ul style="list-style-type: none"> <li>• Count up only</li> <li>• Start counting from <math>0000_H</math>, overflow at <math>FFFF_H</math></li> <li>• Reload event triggered by overflow condition</li> <li>• Reload value fixed at <math>0000_H</math></li> <li>• Capture event triggered by falling/rising edge at pin T2EX</li> <li>• Captured timer value stored in register RC2</li> <li>• Interrupt is generated by reload or capture events</li> </ul>   |



## 17 Timer3

### 17.1 Features

- 16-bit incremental timer/counter (counting up)
- Counting frequency up to  $f_{sys}$
- Selectable clock prescaler
- 6 modes of operation
- Interrupt up on overflow
- Interrupt on compare

### 17.2 Introduction

The possible applications for the timer include measuring the time interval between events, counting events and generating a signal at regular intervals.

Timer3 can function as timer or counter. When functioning as a timer, Timer3 is incremented in periods based on the MI\_CLK or LP\_CLK clock. When functioning as a counter, Timer3 is incremented in response to a 1-to-0 transition (falling edge) at its respective input. Timer3 can be configured in four different operating modes to use in a variety of applications, see [Table 12](#).

Several operating modes can be used for different tasks such as the following:

- simple time measurement between two events
- triggering of the measuring unit upon PWM/CCU6 unit
- measurement of the 100kHz LP\_CLK2

### 17.3 Functional Description

Six modes of operation are provided to fulfill various tasks using this timer. In every mode the clocking source can be selected between MI\_CLK and LP\_CLK. A prescaler provides in addition capability to divide the selected clock source by 2, 4 or 8. The timer counts upwards, starting with the value in the timer count registers, until the maximum count value which depends on the selected mode of operation. Timer 3 provides two individual interrupts upon counter overflow, one for the low-byte and one for the high-byte counter register.

#### 17.3.1 Timer3 Modes Overview

The following table provides an overview of the timer modes together with the reasonable configuration options in [Table 12](#).

**Table 12** Timer3 Modes

| Mode | Sub-Mode    | Operation   |
|------|-------------|---|
| 0    | No Sub-Mode | <b>13-bit Timer</b><br>The timer is essentially an 8-bit counter with a divide-by-32 prescaler.   |
| 1    | a           | <b>16-bit Timer</b><br>The timer registers, TL3 and TH3, are concatenated to form a 16-bit counter.   |
| 1    | b           | <b>16-bit Timer triggered by an event</b><br>The timer registers, TL3 and TH3, are concatenated to form a 16-bit counter, which is triggered by an event to enable a single shot measurement on a preset channel with the measurement unit. |

**Table 12** Timer3 Modes (cont'd)

| Mode | Sub-Mode    | Operation  |
|------|-------------|--|
| 2    | No Sub-Mode | <b>8-bit Timer with auto-reload</b><br>The timer register TL3 is reloaded with a user-defined 8-bit value in TH3 upon overflow.  |
| 3    | a           | <b>Timer3 operates as two 8-bit timers</b><br>The timer registers TL3 and TH3, operate as two separate 8-bit counters.   |
| 3    | b           | <b>Timer3 operates as Two 8-bit timers for clock measurement</b><br>The timer registers, TL3 and TH3 operate as two separate 8-bit counters. In this mode the LP_CLK2 Low Power Clock can be measured. TL3 acts as an edge counter for the clock edges and TH3 as a counter which counts the time between the edges. |

## 18 Capture/Compare Unit 6 (CCU6)

### 18.1 Feature Set Overview

This section gives an overview over the different building blocks and their main features.

#### Timer 12 Block Features

- Three capture/compare channels, each channel can be used either as capture or as compare channel
- Generation of a three-phase PWM supported (six outputs, individual signals for high-side and low-side switches)
- 16-bit resolution, maximum count frequency = peripheral clock
- Dead-time control for each channel to avoid short-circuits in the power stage
- Concurrent update of T12 registers
- Center-aligned and edge-aligned PWM can be generated
- Single-shot mode supported
- Start can be controlled by external events
- Capability of counting external events
- Multiple interrupt request sources
- Hysteresis-like control mode

#### Timer 13 Block Features

- One independent compare channel with one output
- 16-bit resolution, maximum count frequency = peripheral clock
- Concurrent update of T13 registers
- Can be synchronized to T12
- Interrupt generation at period-match and compare-match
- Single-shot mode supported
- Start can be controlled by external events
- Capability of counting external events

#### Additional Specific Functions

- Block commutation for brushless DC-drives implemented
- Position detection via hall-sensor pattern
- Noise filter supported for position input signals
- Automatic rotational speed measurement and commutation control for block commutation
- Integrated error handling
- Fast emergency stop without CPU load via external signal ( $\overline{\text{CTRAP}}$ )
- Control modes for multi-channel AC-drives
- Output levels can be selected and adapted to the power stage

### 18.2 Introduction

The CCU6 unit is made up of a Timer T12 block with three capture/compare channels and a Timer T13 block with one compare channel. The T12 channels can independently generate PWM signals or accept capture triggers, or they can jointly generate control signal patterns to drive DC-motors or inverters.

A rich set of status bits, synchronized updating of parameter values via shadow registers, and flexible generation of interrupt request signals provide efficient software-control.

Capture/Compare Unit 6 (CCU6)

Note: The capture/compare module itself is referred to as CCU6 (capture/compare unit 6). A capture/compare channel inside this module is referred to as CC6x.

The timer T12 can work in capture and/or compare mode for its three channels. The modes can also be combined (e.g. a channel works in compare mode, whereas another channel works in capture mode). The timer T13 can work in compare mode only. The multi-channel control unit generates output patterns which can be modulated by T12 and/or T13. The modulation sources can be selected and combined for the signal modulation.

18.2.1 Block Diagram



Figure 21 CCU6 Block Diagram

## 19 UART1/UART2

### 19.1 Features

- Full-duplex asynchronous modes
  - 8-bit or 9-bit data frames, LSB first
  - fixed or variable baud rate
- Receive buffered
- Multiprocessor communication
- Interrupt generation on the completion of a data transmission or reception
- Baud-rate generator with fractional divider for generating a wide range of baud rates
- Hardware logic for break and synch byte detection

### 19.2 Introduction

The UART provides a full-duplex asynchronous receiver/transmitter, i.e., it can transmit and receive simultaneously. It is also receive-buffered, i.e., it can commence reception of a second byte before a previously received byte has been read from the receive register. However, if the first byte still has not been read by the time reception of the second byte is complete, one of the bytes will be lost. The serial port receive and transmit registers are both accessed at Special Function Register (SFR) SBUF. Writing to SBUF loads the transmit register, and reading SBUF accesses a physically separate receive register.

#### 19.2.1 Block Diagram



Figure 22 UART Block Diagram

### 19.3 UART Modes

The UART can be used in four different modes. In mode 0, it operates as an 8-bit shift register. In mode 1, it operates as an 8-bit serial port. In modes 2 and 3, it operates as a 9-bit serial port. The only difference between mode 2 and mode 3 is the baud rate, which is fixed in mode 2 but variable in mode 3. The variable baud rate is set by the underflow rate on the dedicated baud-rate generator.

The different modes are selected by setting bits SM0 and SM1 to their corresponding values, as shown in [Table 13](#).

**Table 13** UART Modes

| SM0 | SM1 | Operating Mode               | Baud Rate     |
|-----|-----|------------------------------|---------------|
| 0   | 0   | Mode 0: 8-bit shift register | $f_{PCLK}/2$  |
| 0   | 1   | Mode 1: 8-bit shift UART     | Variable      |
| 1   | 0   | Mode 2: 9-bit shift UART     | $f_{PCLK}/64$ |
| 1   | 1   | Mode 3: 9-bit shift UART     | Variable      |

The UART1 is connected to the integrated PWM interface, and to GPIO for test purpose. The UART2 is connected to GPIO only.

## 20 High Voltage PWM Interface

### 20.1 Features

#### General Functional Features

- Bidirectional High Voltage PWM interface

#### Special Features

- PWM interface can be used as a high voltage input/output with dedicated SFR control bits.

#### Operation Modes Features

- High Voltage Input / Output Mode (HVIO)

#### Supported Baudrates

- up to 57.6 kHz

#### Slope Modes Features

- Normal Slope Mode (10 kHz)
- Low Slope Mode (5.2 kHz)
- Flash Mode (57.6 kHz)

#### Wake-Up Features

- High Voltage PWM Interface wake-up

### 20.2 Introduction

The high voltage bidirectional PWM Module is a robust physical layer interface for PWM communication.

The bidirectional PWM Module offers two different operation modes, including a Sleep Mode and the High Voltage Input Output Mode.

20.2.1 Block Diagram

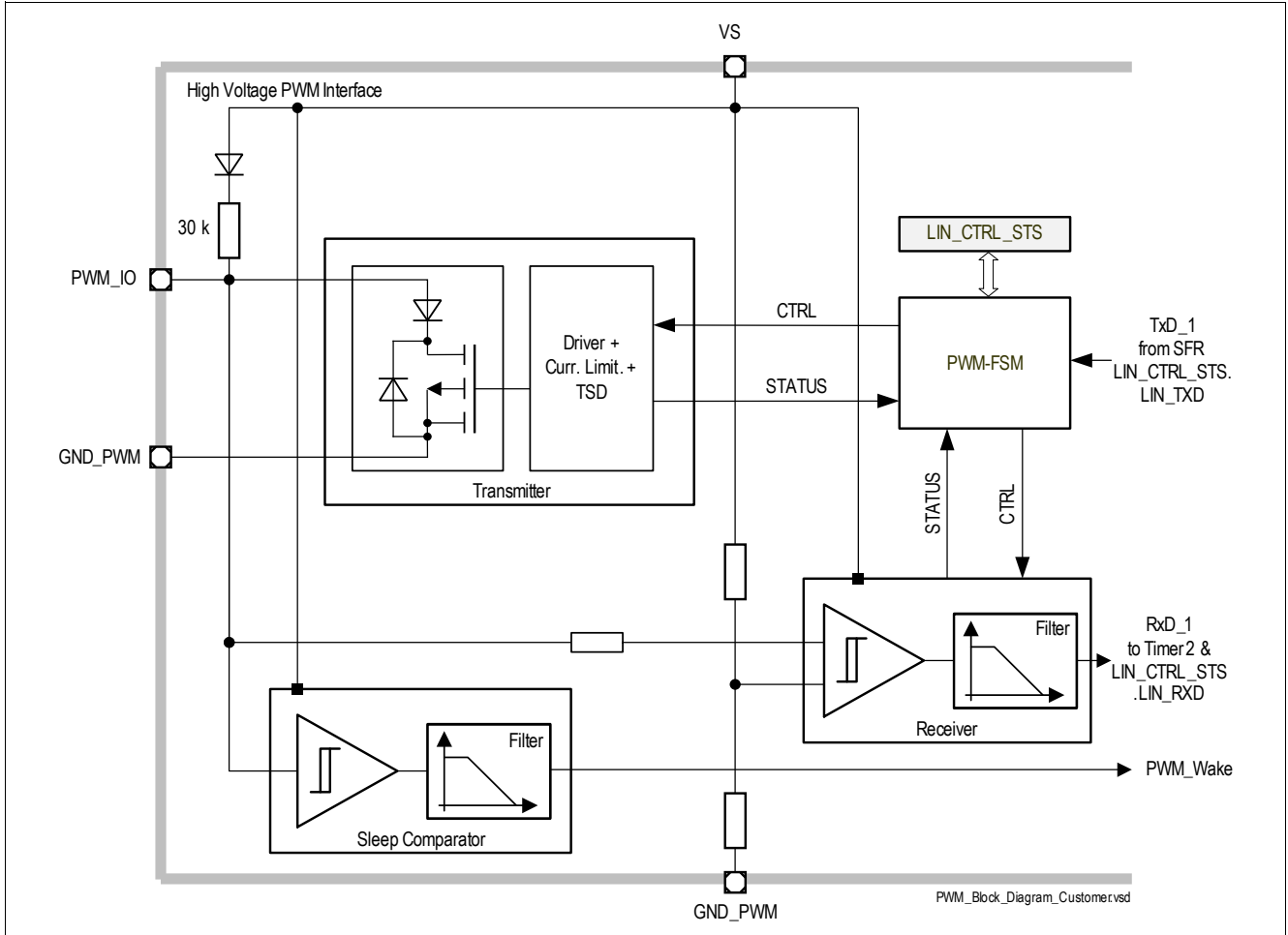

Figure 23 PWM Interface Block Diagram



## 21 High-Speed Synchronous Serial Interface (SSC1/SSC2)

### 21.1 Features

- Master and Slave Mode operation
  - Full-duplex or half-duplex operation
- Transmit and receive buffered
- Flexible data format
  - Programmable number of data bits: 2 to 16 bits
  - Programmable shift direction: Least Significant Bit (LSB) or Most Significant Bit (MSB) shift first
  - Programmable clock polarity: idle low or high state for the shift clock
  - Programmable clock/data phase: data shift with leading or trailing edge of the shift clock
- Variable baud rate
- Compatible with Serial Peripheral Interface (SPI)
- Interrupt generation
  - On a transmitter empty condition
  - On a “receiver full” condition
  - On an error condition (receive, phase, baud rate, transmission error)

## 21.2 Introduction

The High-Speed Synchronous Serial Interface (SSC) supports both full-duplex and half-duplex serial synchronous communication. The serial clock signal can be generated by the SSC internally (master mode), using its own 16-bit baud rate generator, or can be received from an external master (slave mode). Data width, shift direction, clock polarity, and phase are programmable. This allows communication with SPI-compatible devices or devices using other synchronous serial interfaces.

Data is transmitted or received on TXD and RXD lines, which are normally connected to the MTSR (Master Transmit/Slave Receive) and MRST (Master Receive/Slave Transmit) pins. The clock signal is output via line MS\_CLK (Master Serial Shift Clock) or input via line SS\_CLK (Slave Serial Shift Clock). Both lines are normally connected to the pin SCLK. Transmission and reception of data are double-buffered.

### 21.2.1 Block Diagram

Figure 24 shows all functional relevant interfaces associated with the SSC Kernel.



Figure 24 SSC Interface Diagram

## 22 Measurement Unit

### 22.1 Features

- 1 x 8-bit ADC with 10 Inputs including attenuator allowing measurement of high voltage input signals
- Supply Voltage Attenuators with attenuation of **VBAT\_SENSE**, **VS**, **VDDP** and **VDDC**.
- VBG monitoring of 8-bit ADC to guarantee functional safety requirements.
- Bridge Driver Diagnosis Measurement (VDH, VCP).
- Temperature Sensor for monitoring the chip temperature and PMU Regulator temperature.
- Supplement Block with Reference Voltage Generation, Bias Current Generation, Voltage Buffer for NVM Reference Voltage, Voltage Buffer for Analog Module Reference Voltage and Test Interface.

### 22.2 Introduction

The measurement unit is a functional unit that comprises the following associated sub-modules:

**Table 14 Measurement Functions and Associated Modules**

| Module Name                  | Modules   | Functions   |
|------------------------------|---|---|
| Central Functions Unit       | Bandgap reference circuit   | The bandgap-reference sub-module provides two reference voltages<br>1. a trimmable reference voltage for the 8-bit ADCs. A local dedicated bandgap circuit is implemented to avoid deterioration of the reference voltage arising e.g. from crosstalk or ground voltage shift.<br>2. the reference voltage for the NVM module |
| 8-bit ADC (ADC2)             | 8-bit ADC module with 10 multiplexed inputs, including HV input attenuator  | 5 high voltage full supply range capable inputs (2.5V...30,7V(FS))<br>2 medium voltage inputs (0..5V/7V FS).<br>3 low voltage inputs (0..1.2V/1.6V FS)<br>(allocation see following overview figure)  |
| 10-bit ADC (ADC1)            | 10-bit ADC module with 8 multiplexed inputs   | Five (5V) analog inputs from Port 2.x   |
| VDH Input Voltage Attenuator | VDH input voltage attenuator  | Scales down V(VDH) to the input voltage range of ADC1.CH6   |
| Temperature Sensor           | Temperature sensor with two multiplexed sensing elements: <ul style="list-style-type: none"> <li>• PMU located sensor</li> <li>• Central chip located sensor</li> </ul> | Generates output voltage which is a linear function of the local chip (junction) temperature.   |
| Measurement Core Module      | Digital signal processing and ADC2 control unit   | 1. Generates the control signal for the 8-bit ADC2 and the synchronous clock for the switched capacitor circuits,<br>2. Performs digital signal processing functions and provides status outputs for interrupt generation.  |

### 22.2.1 Block Diagram

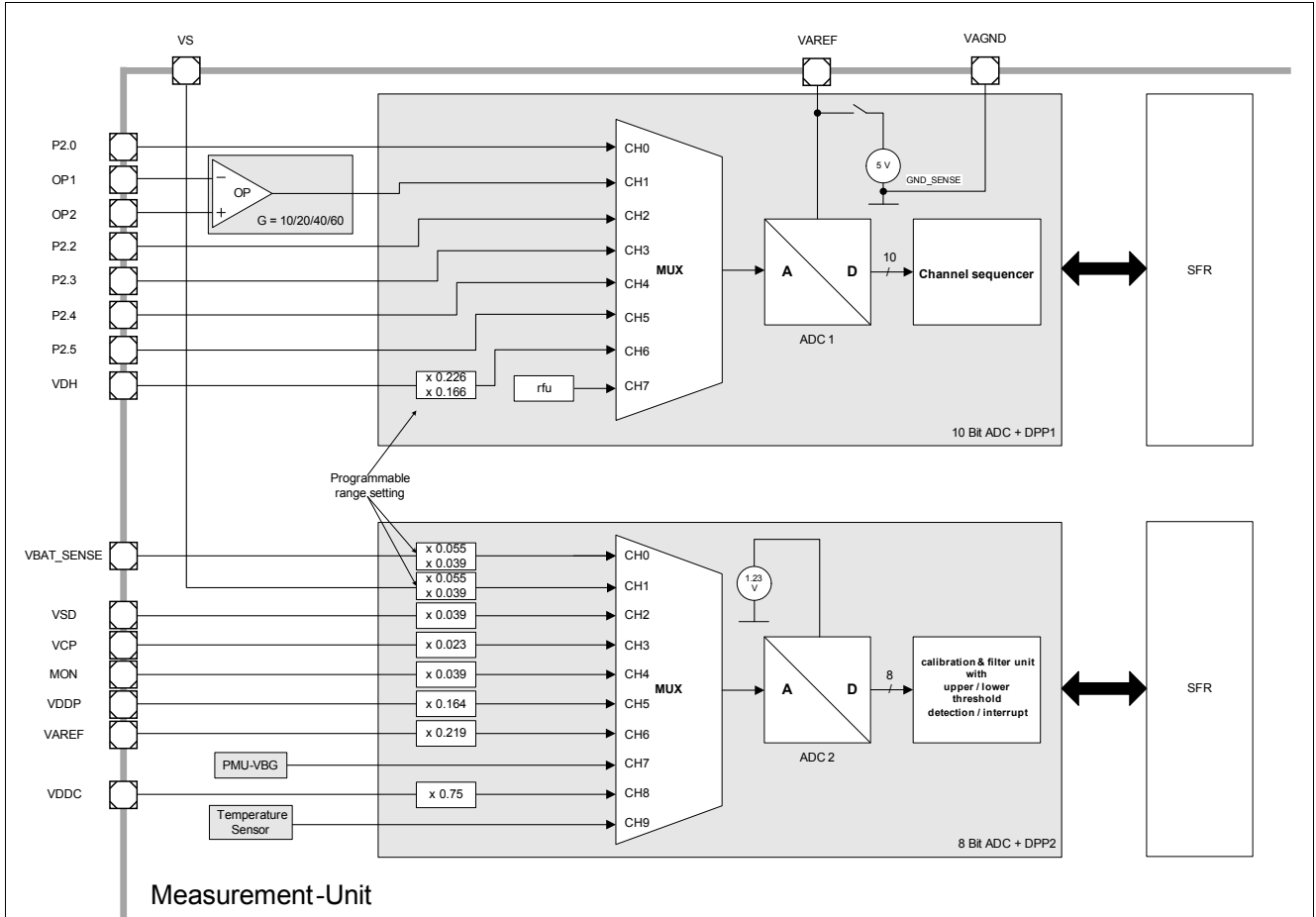

Figure 25 Measurement Unit-Overview (with opamp)

## 23 Measurement Core Module (incl. ADC2)

### 23.1 Features

- 8 individually programmable channels split into two groups of user configurable and non user configurable
- Individually programmable channel prioritization scheme for measurement unit
- Two independent filter stages with programmable low-pass and time filter characteristics for each channel
- Two channel configurations:
  - Programmable upper- and lower trigger thresholds comprising a fully programmable hysteresis
  - Two individually programmable trigger thresholds with limit hysteresis settings
- Individually programmable interrupts and statuses for all channel thresholds

### 23.2 Introduction

The basic function of this block is the digital postprocessing of several analog digitized measurement signals by means of filtering, level comparison and interrupt generation. The measurement postprocessing block consists of ten identical channel units attached to the outputs of the 10-channel 8-bit ADC (ADC2). It processes ten channels, where the channel sequence and prioritization is programmable within a wide range.

#### 23.2.1 Block Diagram

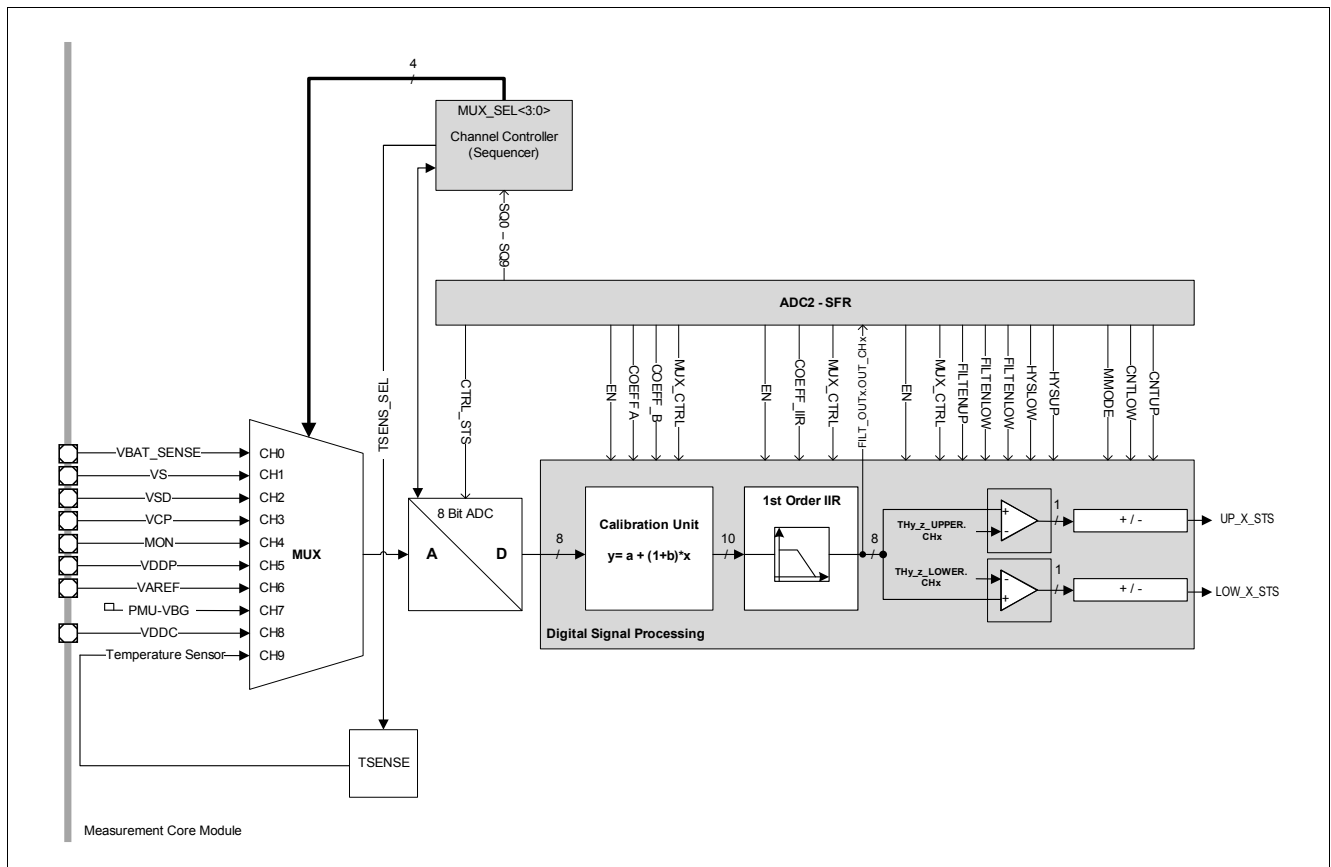

Figure 26 Module Block Diagram

## 23.2.2 Measurement Core Module Modes Overview

The basic function of this unit, is the digital signal processing of several analog digitized measurement signals by means of filtering, level comparison and interrupt generation. The Measurement Core module processes ten channels in a quasi parallel process.

As shown in the figure above, the ADC2 postprocessing unit consists of a channel controller (Sequencer), an 10-channel demultiplexer and the signal processing block, which filters and compares the sampled ADC2 values for each channel individually. The channel control block controls the multiplexer sequencing on the analog side before the ADC2 and on the digital domain after the ADC2. As described in the following section, the channel sequence can be controlled in a flexible way, which allows a certain degree of channel prioritization.

This capability can be used e.g. to set a higher priority to supply voltage channels compared to the other channel measurements. The Measurement Core Module offers additionally two different post-processing measurement modes for over-/undervoltage detection and for two-level threshold detection.

The channel controller (sequencer) runs in one of the following modes:

“Normal Sequencer Mode” – channels are selected according to the 10 sequence registers which contain individual enablers for each of the 10 channels.

“Exceptional Interrupt Measurement” – following a hardware event, a high priority channel is inserted into the current sequence. The current actual measurement is not destroyed.

“Exceptional Sequence Measurement” – following a hardware event, a complete sequence is inserted after the current measurement is finished. The current sequence is interrupted by the exception sequence.

## 24 10-Bit Analog Digital Converter (ADC1)

### 24.1 Features

The principal features of the ADC1 are:

- Up to 8 analog input channels (channel 7 reserved for future use)
- Flexible results handling
  - 8-bit and 10-bit resolution
- Flexible source selection due to sequencer
  - insert one exceptional sequence (ESM)
  - insert one interrupt measurement into the current sequence (EIM), single or up to 128 times
  - software mode
- Conversion sample time (separate for each channel) adjustable to adapt to sensors and reference
- Standard external reference (VAREF) to support ratiometric measurements and different signal scales
- DMA support, transfer ADC conversion results via DMA into RAM
- Support of suspend and power saving modes
- Result data protection for slow CPU access (wait-for-read mode)
- Programmable clock divider
- Integrated sample and hold circuitry

### 24.2 Introduction

The TLE9861QXA20 includes a high-performance 10-bit Analog-to-Digital Converter (ADC1) with eight multiplexed analog input channels. The ADC1 uses a successive approximation technique to convert the analog voltage levels from up to eight different sources. The analog input channels of the ADC1 are available at AN0, AN2 - AN5.

### 24.2.1 Block Diagram

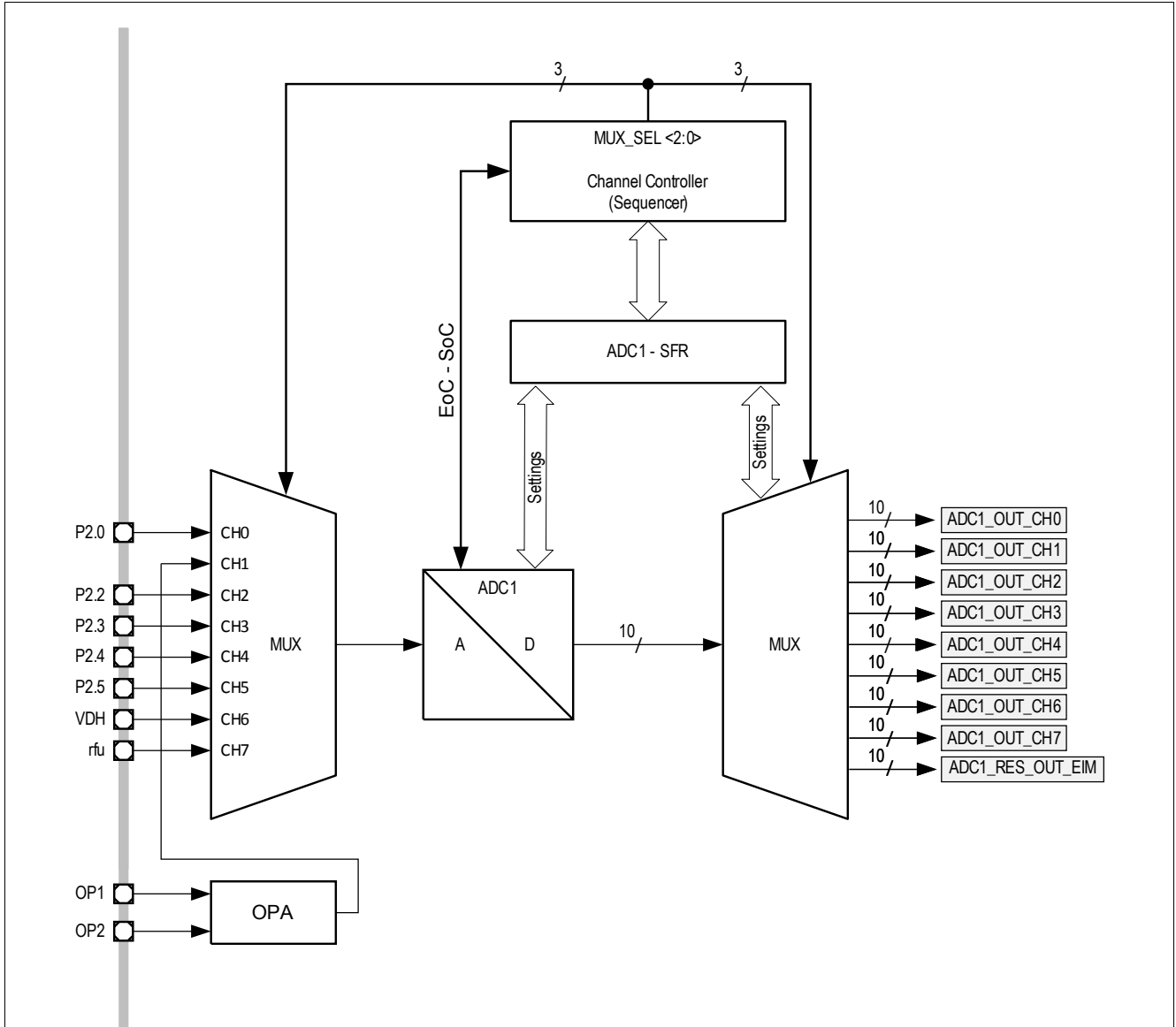

**Figure 27 ADC1 Top Level Block Diagram**

As shown in the figure above, the ADC1 postprocessing consists of a channel controller (Sequencer) and an 8-channel demultiplexer. The channel control block controls the multiplexer sequencing on the analog side before the ADC1 and on the digital domain after the ADC1. As described in the following section, the channel sequence can be controlled in a flexible way, which allows a certain degree of channel prioritization.

This capability can be used e.g. to give a higher priority to some channels compared to the other channel measurements.



## 25 High-Voltage Monitor Input

### 25.1 Features

- High-voltage input with  $V_{GS}/2$  threshold voltage
- Integrated selectable pull-up and pull-down current sources
- Wake capability for power saving modes
- Level change sensitivity configurable for transitions from low to high, high to low or both directions

### 25.2 Introduction

This module is dedicated to monitor external voltage levels above or below a specified threshold or it can be used to detect a wake-up event at the high-voltage MON pin in low-power mode. The input is sensitive to a input level monitoring, this is available when the module is switched to active mode with the SFR bit EN.

To use the Wake function during low power mode of the IC, the monitoring pin is switched to Sleep Mode via the SFR bit EN.

#### 25.2.1 Block Diagram

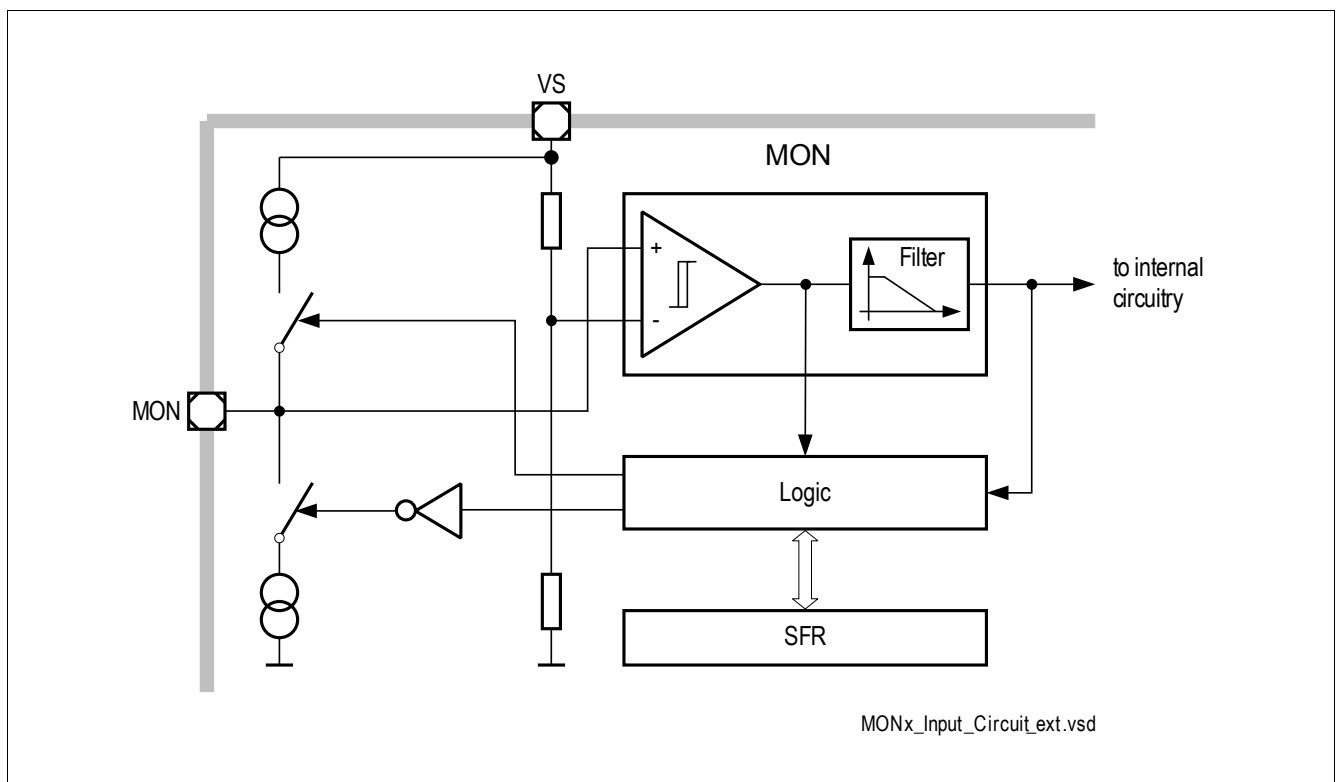

Figure 28 Monitoring Input Block Diagram

## 26 Bridge Driver (incl. Charge Pump)

### 26.1 Features

The MOSFET Driver is intended to drive external normal level NFET transistors in bridge configuration. The driver provides many diagnostic possibilities to detect faults.

#### Functional Features

- External Power NFET Transistor Driver Stage with driver capability for max. 100 nC gate charge @ 25 kHz switching frequency.
- Implemented adjustable cross conduction protection.
- Supply voltage (VSD) monitoring incl. adjustable over- and undervoltage shutdown with configurable interrupt signalling.
- VSD operating range down to 5.4 V
- VDS comparators for short circuit detection in on- and off-state
- Open-Load detection in off-state

### 26.2 Introduction

The MOSFET Driver Stage can be used for controlling external Power NFET Transistors (normal level). The module output is controlled by SFR or System PWM Machine (CCU6).

### 26.2.1 Block Diagram

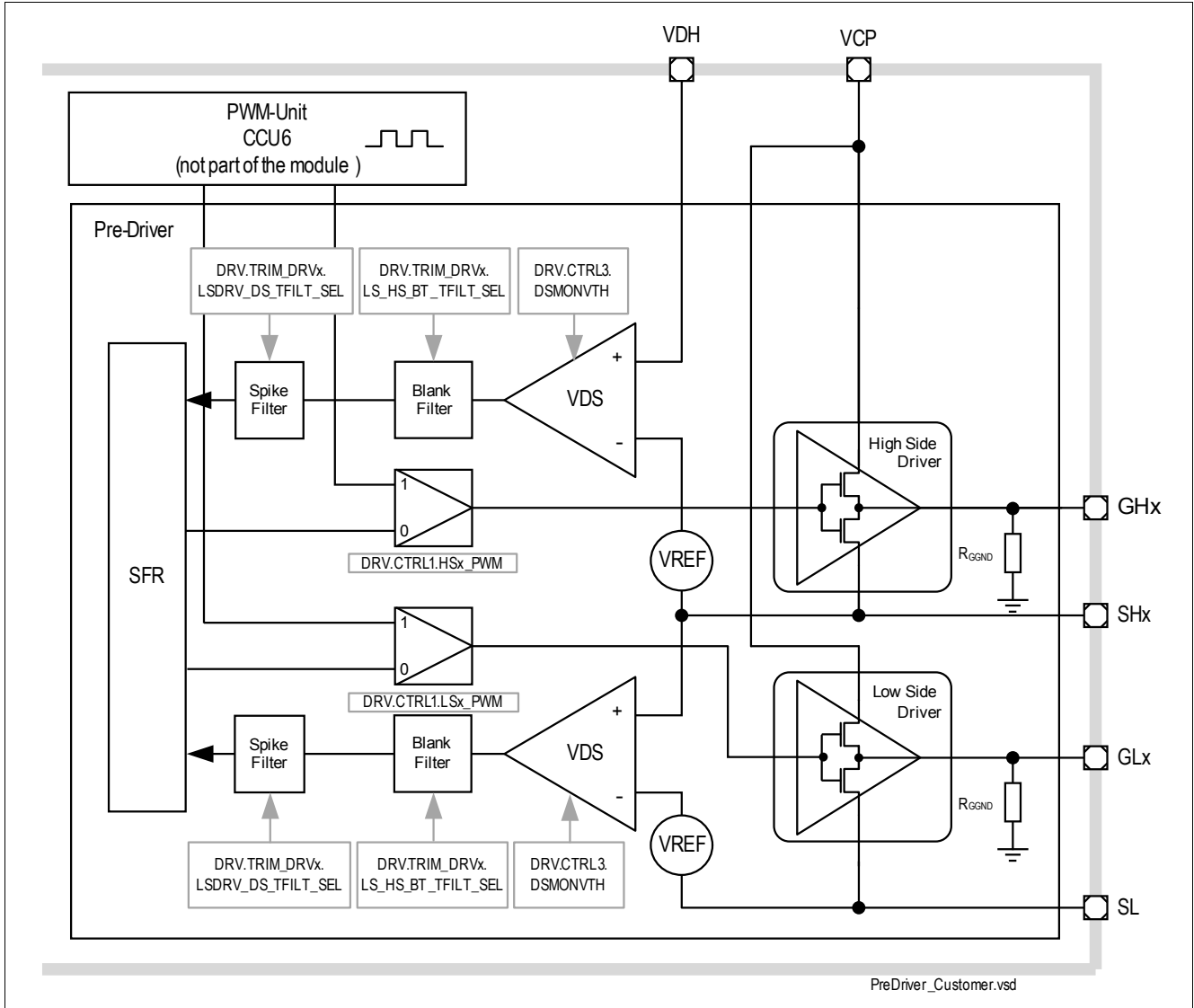

Figure 29 Driver Module Block Diagram (incl. system connections)

### 26.2.2 General

The Driver can be controlled in two different ways:

- In Normal Mode the output stage is fully controllable through the SFR registers CTRLx (x = 1,2,3). Protection functions such as overcurrent and open-load detection are available.
- The PWM Mode can also be enabled by the corresponding bit in CTRL1 and CTRL2. The PWM must be configured in the System PWM Module (CCU6). All protection functions are available in PWM mode as well.

#### Protection Functions

- Overcurrent detection and shutdown feature for external MOSFET by Drain Source measurement
- Programmable minimum cross current protection time
- Open-load detection feature in Off-state for external MOSFET.

## 27 Current Sense Amplifier

### 27.1 Features

#### Main Features

- Programmable gain settings:  $G = 10, 20, 40, 60$
- Differential input voltage:  $\pm 1.5V / G$
- Wide common mode input range  $\pm 2V$
- Low setting time  $< 1.4 \mu s$

### 27.2 Introduction

The current sense amplifier in **Figure 30** can be used to measure near ground differential voltages via the 10-bit ADC. Its gain is digitally programmable through internal control registers.

Linear calibration has to be applied to achieve high gain accuracy, e.g. end-of-line calibration including the shunt resistor.

**Figure 30** shows how the current sense amplifier can be used as a low-side current sense amplifier where the motor current is converted to a voltage by means of a shunt resistor  $R_{SH}$ . A differential amplifier input is used in order to eliminate measurement errors due to voltage drop across the stray resistance  $R_{Stray}$  and differences between the external and internal ground. If the voltage at one or both inputs is out of the operating range, the input circuit is overloaded and requires a certain specified **recovery time**.

In general, the external low pass filter should provide suppression of EMI.

#### 27.2.1 Block Diagram

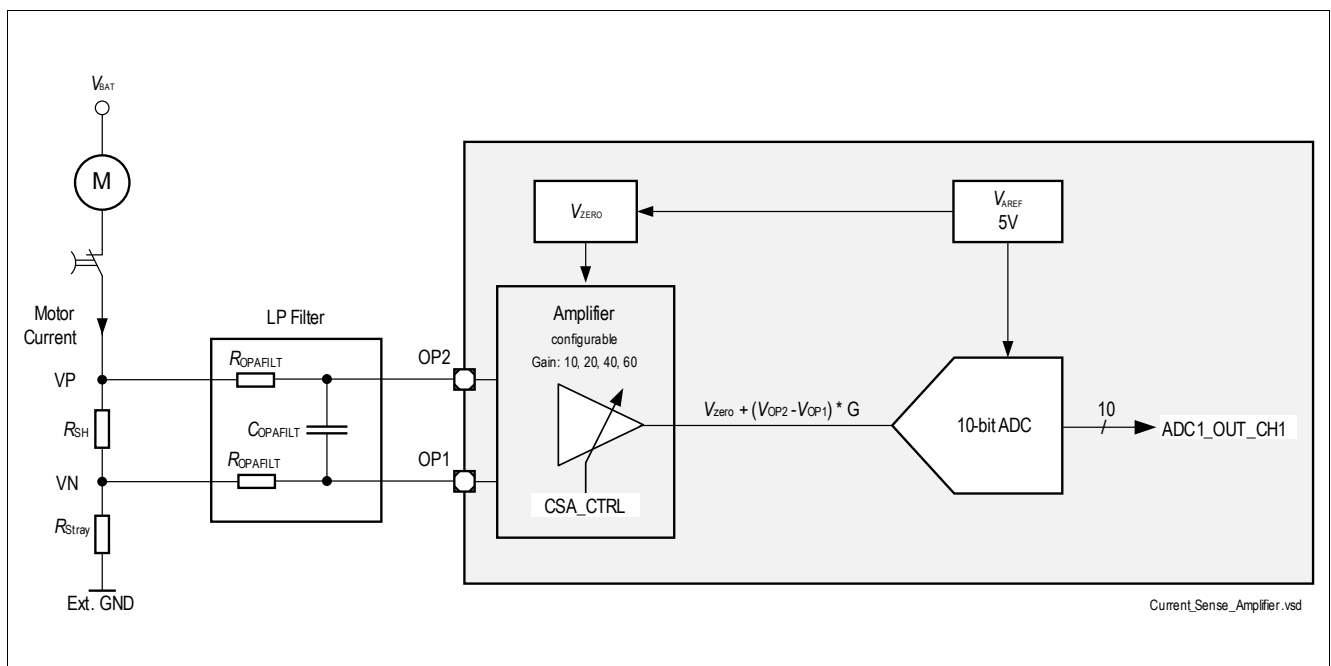

**Figure 30** Simplified Application Diagram

## 28 Application Information

### 28.1 H-Bridge Driver

**Figure 31** shows the TLE9861QXA20 in an electric drive application setup controlling an H-Bridge motor.

*Note: The following information is given as a hint for the implementation of the device only and shall not be regarded as a description or warranty of a certain functionality, condition or quality of the device.*

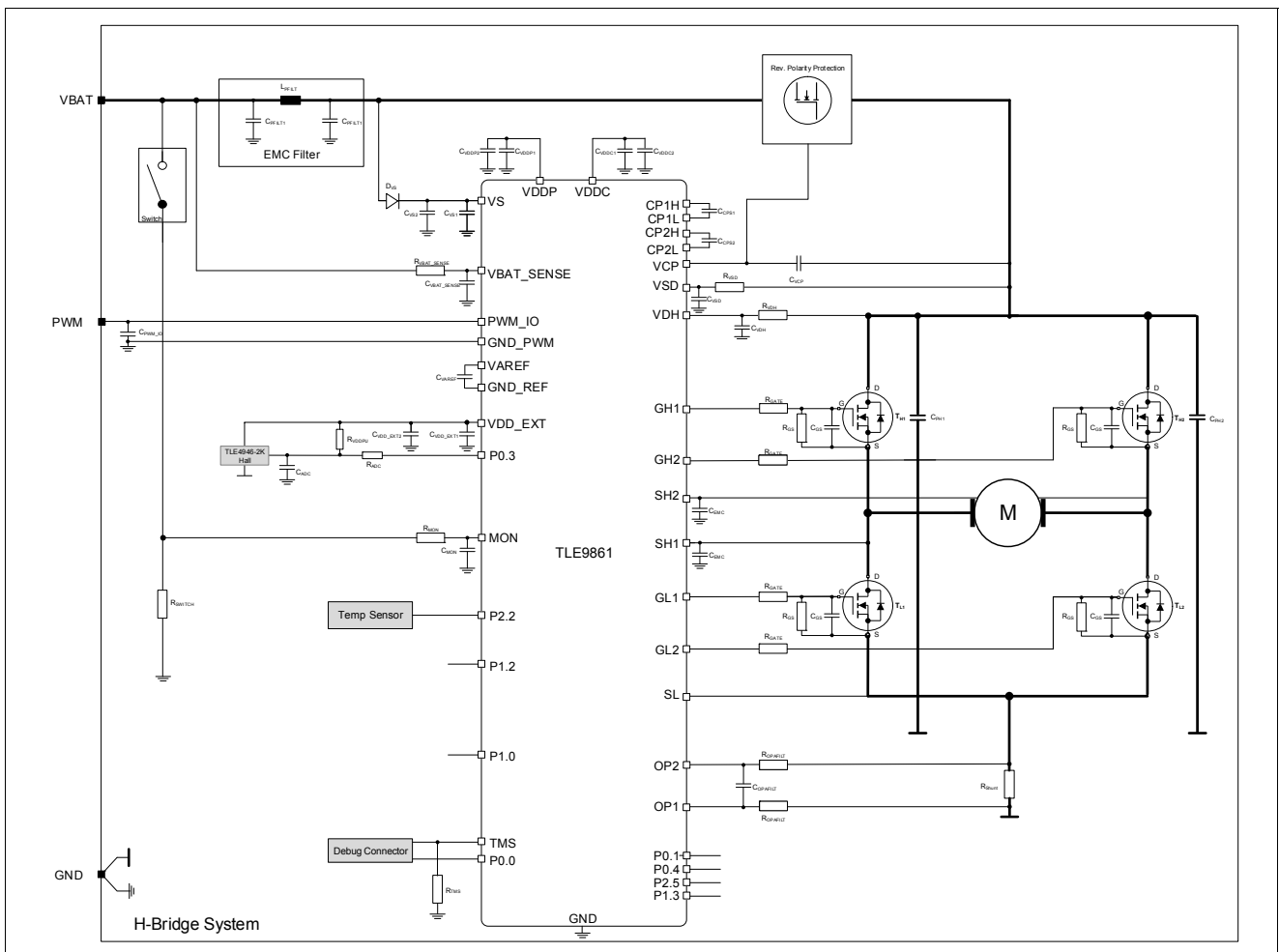

**Figure 31 Simplified Application Diagram Example**

*Note: This is a very simplified example of an application circuit and bill of materials. The function must be verified in the actual application.*

**Table 15 External Components (BOM)**

| Symbol                                    | Function  | Component                          |
|---|---|------------------------------------|
| C <sub>VS1</sub>                          | Blocking capacitor at VS pin  | ≥ 100 nF Ceramic, ESR < 1 Ω        |
| C <sub>VS2</sub>                          | Blocking capacitor at VS pin  | > 2.2 μF Elco <sup>1)</sup>        |
| C <sub>VDDP</sub>                         | Blocking capacitor at VDDP pin  | 470 nF + 100 nF Ceramic, ESR < 1 Ω |
| C <sub>VDD_EXT</sub>                      | Blocking capacitor at VDDEXT pin  | 100nF, Ceramic ESR < 1 Ω           |
| C <sub>VDDC</sub>                         | Blocking capacitor at VDDC pin  | 470 nF + 100 nF Ceramic, ESR < 1 Ω |
| C <sub>VAREF</sub>                        | Blocking capacitor at VAREF pin   | 100 nF, Ceramic ESR < 1 Ω          |
| C <sub>PWM_IO</sub>                       | Standard C for PWM Interface slave  | –                                  |
| C <sub>VSD</sub>                          | Filter C for charge pump end driver   | 1 μF                               |
| C <sub>CPS1</sub>                         | Charge pump capacitor   | 220 nF                             |
| C <sub>CP2S</sub>                         | Charge pump capacitor   | 220 nF                             |
| C <sub>VCP</sub>                          | Charge pump capacitor   | 470 nF                             |
| C <sub>MON1</sub>                         | Filter C for ISO pulses   | 10 nF                              |
| C <sub>VDH</sub>                          | Capacitor   | 1 nF                               |
| C <sub>PH1</sub>                          | Capacitor   | 220 μF                             |
| C <sub>PH2</sub>                          | Capacitor   | 220 μF                             |
| C <sub>OPAFILT</sub>                      | Capacitor   | 100 nF                             |
| C <sub>EMCP1</sub>                        | Capacitor   | 1 nF                               |
| C <sub>EMCP2</sub>                        | Capacitor   | 1 nF                               |
| C <sub>PFILT1</sub> , C <sub>PFILT2</sub> | Capacitor   | 10 μF                              |
| C <sub>VBAT_SENSE</sub>                   | Capacitor   | 10 nF                              |
| R <sub>MON</sub>                          | Resistor at MON pin   | 1 kΩ                               |
| R <sub>VSD</sub>                          | Limitation of reverse current due to transient (-2V, 8ms)<br>max. ratings of the VSD pin has to be met, alternatively the resistor shall be replaced by a diode | 2 Ω                                |
| R <sub>VDH</sub>                          | Resistor  | 1 kΩ                               |
| R <sub>GATE</sub>                         | Resistor  | 2 Ω                                |
| R <sub>OPAFILT</sub>                      | Resistor  | 12 Ω                               |
| R <sub>VBAT_SENSE</sub>                   | Resistor  |                                    |
| R <sub>SH1</sub>                          | Resistor  | optional                           |
| R <sub>SH2</sub>                          | Resistor  | optional                           |
| L <sub>PFILT</sub>                        |   |                                    |
| D <sub>VS</sub>                           | Reverse-polarity protection diode   | –                                  |

1) The capacitor must be dimensioned so as to ensure that flash operations modifying the content of the flash are never interrupted (e.g. in case of power loss).

## 28.2 ESD Immunity According to IEC61000-4-2

Note: Tests for ESD immunity according to IEC61000-4-2 “Gun test” (150pF, 330Ω) has been performed. The results and test condition will be available in a test report.

**Table 16 ESD “Gun Test”**

| Performed Test                              | Result | Unit | Remarks                      |
|---|--------|------|------------------------------|
| ESD at pin PWM_IO, versus GND <sup>1)</sup> | > 6    | kV   | <sup>2)</sup> positive pulse |
| ESD at pin PWM_IO, versus GND <sup>1)</sup> | < -6   | kV   | <sup>2)</sup> negative pulse |

1) ESD test “ESD GUN” is specified with external components; see application diagram:

$C_{MON} = 100 \text{ nF}$ ,  $R_{MON} = 1 \text{ k}\Omega$ ,  $C_{PWM\_IO} = 220 \text{ pF}$ ,  $C_{VS} = >20 \text{ }\mu\text{F ELCO} + 100 \text{ nF ESR} < 1 \text{ }\Omega$ ,  $C_{VSD} = 1 \text{ }\mu\text{F}$ ,  $R_{VSD} = 2 \text{ }\Omega$ .

2) ESD susceptibility “ESD GUN” according to LIN EMC Test Specification, Section 4.3 (IEC 61000-4-2). Tested by external test house (IBEE Zwickau, EMC Test report Nr. 09-07-14)

## 29 Electrical Characteristics

This chapter includes all relevant electrical characteristics of the product TLE9861QXA20.

### 29.1 General Characteristics

#### 29.1.1 Absolute Maximum Ratings

**Table 17 Absolute Maximum Ratings<sup>1)</sup>**

$T_j = -40\text{ °C}$  to  $+150\text{ °C}$ , all voltages with respect to ground, positive current flowing into pin (unless otherwise specified)

| Parameter                           | Symbol                   | Values |      |      | Unit | Note / Test Condition  | Number   |
|-------------------------------------|--------------------------|--------|------|------|------|--|----------|
|                                     |                          | Min.   | Typ. | Max. |      |  |          |
| <b>Voltages – Supply Pins</b>       |                          |        |      |      |      |  |          |
| Supply voltage – VS                 | $V_S$                    | -0.3   | –    | 40   | V    | Load dump  | P_1.1.1  |
| Supply voltage – VSD                | $V_{SD}$                 | -0.3   | –    | 48   | V    | –  | P_1.1.2  |
| Supply voltage – VSD                | $V_{SD\_max\_extend}$    | -2.8   | –    | 48   | V    | Series resistor $R_{VSD} = 2.2\ \Omega$ , $t = 8\text{ ms}$ <sup>2)</sup>  | P_1.1.32 |
| Voltage range – VDDP                | $V_{DDP}$                | -0.3   | –    | 5.5  | V    | –  | P_1.1.3  |
| Voltage range – VDDP                | $V_{DDP\_max\_extend}$   | -0.3   | –    | 7    | V    | In case of voltage transients on $V_S$ with $dV_S/dt \geq 1\text{V}/\mu\text{s}$ ; duration: $t \leq 150\mu\text{s}$ ; $C_{VDDP} \leq 570\text{ nF}$   | P_1.1.41 |
| Voltage range – VDDEXT              | $V_{DDEXT}$              | -0.3   | –    | 5.5  | V    | –  | P_1.1.4  |
| Voltage range – VDDEXT              | $V_{DDEXT\_max\_extend}$ | -0.3   | –    | 7    | V    | In case of voltage transients on $V_S$ with $dV_S/dt \geq 1\text{V}/\mu\text{s}$ ; duration: $t \leq 150\mu\text{s}$ ; $C_{VDDEXT} \leq 570\text{ nF}$ | P_1.1.42 |
| Voltage range – VDDC                | $V_{DDC}$                | -0.3   | –    | 1.6  | V    | –  | P_1.1.5  |
| <b>Voltages – High Voltage Pins</b> |                          |        |      |      |      |  |          |
| Battery voltage VBAT_SENSE          | $V_{BAT\_SENSE}$         | -28    | –    | 40   | V    | <sup>3)</sup>  | P_1.1.6  |
| Input voltage at PWM_IO             | $V_{PWM\_IO}$            | -28    | –    | 40   | V    | –  | P_1.1.7  |
| Input voltage at MON                | $V_{MON\_maxrate}$       | -28    | –    | 40   | V    | <sup>4)</sup>  | P_1.1.8  |
| Input voltage at VDH                | $V_{VDH\_maxrate}$       | -2.8   | –    | 40   | V    | <sup>5)</sup>  | P_1.1.38 |
| Voltage range at GHx                | $V_{GH}$                 | -8.0   | –    | 48   | V    | <sup>6)</sup>  | P_1.1.9  |
| Voltage range at GHx vs. SHx        | $V_{GHvsSH}$             | 14     | –    | –    | V    | –  | P_1.1.44 |
| Voltage range at SHx                | $V_{SH}$                 | -8.0   | –    | 48   | V    | –  | P_1.1.11 |
| Voltage range at GLx                | $V_{GL}$                 | -8.0   | –    | 48   | V    | <sup>7)</sup> –  | P_1.1.13 |
| Voltage range at GLx vs. SL         | $V_{GLvsSL}$             | 14     | –    | –    | V    | –  | P_1.1.45 |



**Electrical Characteristics**
**Table 17 Absolute Maximum Ratings<sup>1)</sup> (cont'd)**

$T_j = -40\text{ °C}$  to  $+150\text{ °C}$ , all voltages with respect to ground, positive current flowing into pin (unless otherwise specified)

| Parameter  | Symbol               | Values |      |                 | Unit         | Note / Test Condition                | Number   |
|--|----------------------|--------|------|-----------------|--------------|--------------------------------------|----------|
|  |                      | Min.   | Typ. | Max.            |              |                                      |          |
| Voltage range at charge pump pins CP1H, CP1L, CP2H, CP2L, VCP                          | $V_{CPx}$            | -0.3   | –    | 48              | V            | 8)                                   | P_1.1.15 |
| <b>Voltages – GPIOs</b>  |                      |        |      |                 |              |                                      |          |
| Voltage on any port pin <sup>9)</sup>  | $V_{in}$             | -0.3   | –    | $V_{DDP} + 0.3$ | V            | $V_{IN} < V_{DDPmax}$ <sup>10)</sup> | P_1.1.16 |
| <b>Current at VCP Pin</b>  |                      |        |      |                 |              |                                      |          |
| Max. current at VCP pin  | $I_{VCP}$            | -15    | –    | –               | mA           | –                                    | P_1.1.35 |
| <b>Injection Current at GPIOs</b>  |                      |        |      |                 |              |                                      |          |
| Injection current on any port pin  | $I_{GPIONM}$         | -5     | –    | 5               | mA           | 11)                                  | P_1.1.34 |
| Sum of all injected currents in Normal Mode  | $I_{GPIOAM\_sum}$    | -50    | –    | 50              | mA           | 11)                                  | P_1.1.30 |
| Sum of all injected currents in Power Down Mode (Stop Mode)                            | $I_{GPIOPD\_sum}$    | -5000  | –    | 50              | $\mu$ A      | 11)                                  | P_1.1.36 |
| Sum of all injected currents in Sleep Mode   | $I_{GPIOSleep\_sum}$ | -5     | –    | 5               | mA           | 11)                                  | P_1.1.37 |
| <b>Other Voltages</b>  |                      |        |      |                 |              |                                      |          |
| Input voltage VAREF  | $V_{AREF}$           | -0.3   | –    | $V_{DDP} + 0.3$ | V            | –                                    | P_1.1.17 |
| Input voltage OP1, OP2   | $V_{OAI}$            | -7     | –    | 7               | V            | –                                    | P_1.1.23 |
| <b>Temperatures</b>  |                      |        |      |                 |              |                                      |          |
| Junction temperature   | $T_j$                | -40    | –    | 150             | $^{\circ}$ C | –                                    | P_1.1.18 |
| Storage temperature  | $T_{stg}$            | -55    | –    | 150             | $^{\circ}$ C | –                                    | P_1.1.19 |
| <b>ESD Susceptibility</b>  |                      |        |      |                 |              |                                      |          |
| ESD susceptibility all pins  | $V_{ESD1}$           | -2     | –    | 2               | kV           | HBM <sup>12)</sup>                   | P_1.1.20 |
| ESD susceptibility pins MON, VS, VSD, VBAT_SENSE vs.GND                                | $V_{ESD2}$           | -4     | –    | 4               | kV           | HBM <sup>13)</sup>                   | P_1.1.21 |
| ESD susceptibility pins PWM_IO vs. GND_PWM   | $V_{ESD3}$           | -6     | –    | 6               | kV           | HBM <sup>12)</sup>                   | P_1.1.22 |
| ESD susceptibility <b>CDM</b> all pins vs. GND   | $V_{ESD\_CDM1}$      | -500   | –    | 500             | V            | 14)                                  | P_1.1.28 |
| ESD susceptibility <b>CDM</b> pins 1, 12, 13, 24, 25, 36, 37, 48 (corner pins) vs. GND | $V_{ESD\_CDM2}$      | -750   | –    | 750             | V            | 14)                                  | P_1.1.43 |

1) Not subject to production test, specified by design.

2) Conditions and min. value is derived from application condition for reverse polarity event.

---

**Electrical Characteristics**

- 3) Min voltage -28V with external 3.9k $\Omega$  series resistor only.
- 4) Min voltage -28V with external 3.9k $\Omega$  series resistor only.
- 5) Min voltage -2.8V with external 1k $\Omega$  series resistor only.
- 6) To achieve max. ratings on this pin, Parameter P\_1.1.44 has to be taken into account resulting in the following dependency:  
 $V_{GH} < V_{SH} + V_{GHvsSH\_min}$  and additionally  $V_{SH} < V_{GH} + 0.3V$ .
- 7) To achieve max. ratings on this pin, Parameter P\_1.1.45 has to be taken into account resulting in the following dependency:  
 $V_{GL} < V_{SL} + V_{GLvsSL\_min}$  and additionally  $V_{SL} < V_{GL} + 0.3V$ .
- 8) These limits can be kept if max current drawn out of pin does not exceed limit of 200  $\mu A$ .
- 9) See XTAL parameter specification, when GPIOs (Port Pin P2.0 and P2.2) are used as XTAL.
- 10) Includes TMS and RESET.
- 11) Maximum rating for injection current of GPIO with  $V_{IN}$  respected.
- 12) ESD susceptibility HBM according to ANSI/ESDA/JEDEC JS-001 (1.5k $\Omega$ , 100pF)
- 13) MON with external circuitry of a series resistor of 3.9k $\Omega$  and 10nF (at connector); VS with an external ceramic capacitor of 100nF; VSD with an external capacitor of 470nF; VDH with external circuitry of a series resistor of 1k $\Omega$  and 3.3nF (at pin).
- 14) ESD susceptibility, HBM according to ANSI/ESDA/JEDEC JESD22-C101F

**Notes**

1. *Stresses above the ones listed here may cause permanent damage to the device. Exposure to absolute maximum rating conditions for extended periods may affect device reliability.*
2. *Integrated protection functions are designed to prevent IC destruction under fault conditions described in the data sheet. Fault conditions are considered as "outside" normal operating range. Protection functions are not designed for continuous repetitive operation.*

**29.1.2 Functional Range**
**Table 18 Functional Range**

$T_j = -40\text{ °C}$  to  $+150\text{ °C}$ , all voltages with respect to ground, positive current flowing into pin (unless otherwise specified)

| Parameter  | Symbol                  | Values |      |      | Unit       | Note / Test Condition                               | Number   |
|--|-------------------------|--------|------|------|------------|---|----------|
|  |                         | Min.   | Typ. | Max. |            |   |          |
| Supply voltage in Active Mode  | $V_{S\_AM}$             | 5.5    | –    | 28   | V          | –   | P_1.2.1  |
| Extended supply voltage in Active Mode   | $V_{S\_AM\_extended}$   | 28     | –    | 40   | V          | <sup>1)</sup> Functional with parameter deviation   | P_1.2.16 |
| Supply voltage in Active Mode for MOSFET Driver Supply   | $V_{SD\_AM}$            | 5.4    | –    | 28   | V          |   | P_1.2.18 |
| Extended supply voltage in Active Mode for MOSFET Driver Supply  | $V_{SD\_AM\_extended}$  | 28     | –    | 32   | V          | <sup>1,3)</sup> Functional with parameter deviation | P_1.2.17 |
| Specified supply voltage for PWM interface   | $V_{S\_AM\_PWM\_M\_IO}$ | 5.5    | –    | 18   | V          | Parameter Specification                             | P_1.2.2  |
| Extended supply voltage for PWM interface  | $V_{S\_AM\_PWM\_M\_IO}$ | 4.8    | –    | 28   | V          | Functional with parameter deviation                 | P_1.2.14 |
| Supply voltage in Active Mode with reduced functionality (Microcontroller / Flash with full operation) | $V_{S\_AMmin}$          | 3.0    | –    | 5.5  | V          | <sup>2)</sup>                                       | P_1.2.3  |
| Supply voltage in Sleep Mode   | $V_{S\_Sleep}$          | 3.0    | –    | 28   | V          | –   | P_1.2.4  |
| Supply voltage transients slew rate  | $dV_S/dt$               | -1     | –    | 1    | V/ $\mu$ s | <sup>3)</sup>                                       | P_1.2.5  |
| Output sum current for all GPIO pins   | $I_{GPIO\_sum}$         | -50    | –    | 50   | mA         | <sup>3)</sup>                                       | P_1.2.7  |
| Operating frequency  | $f_{sys}$               | 5      | –    | 24   | MHz        | <sup>4)</sup>                                       | P_1.2.20 |
| Junction temperature   | $T_j$                   | -40    | –    | 150  | °C         | –   | P_1.2.9  |

1) This operation voltage range is only allowed for a short duration:  $t_{max} \leq 400\text{ ms}$  (continuous operation at this voltage is not allowed),  $f_{sys} = 24\text{ MHz}$ ,  $I_{VDDP} = 10\text{ mA}$ ,  $I_{VDDEXT} = 5\text{ mA}$ . In addition, the power dissipation caused by the Charge Pump + MOSFET driver have to be considered.

2) Reduced functionality (e.g. cranking pulse) - Parameter deviation possible.

3) Not subject to production test, specified by design.

4) Function not specified when limits are exceeded.

**29.1.3 Current Consumption**
**Table 19 Electrical Characteristics**

$V_S = 5.5 \text{ V to } 28 \text{ V}$ ,  $T_j = -40 \text{ }^\circ\text{C to } +150 \text{ }^\circ\text{C}$ ; all voltages with respect to ground, positive current flowing into pin (unless otherwise specified)

| Parameter  | Symbol                       | Values |      |      | Unit          | Note / Test Condition   | Number   |
|--|------------------------------|--------|------|------|---------------|---|----------|
|  |                              | Min.   | Typ. | Max. |               |   |          |
| <b>Current Consumption @VS pin</b>               |                              |        |      |      |               |   |          |
| Current consumption in Active Mode at pin VS     | $I_{VS}$                     | –      | 30   | 35   | mA            | $f_{\text{sys}} = 20 \text{ MHz}$<br>no loads on pins, PWM interface in recessive state <sup>1)</sup>   | P_1.3.1  |
| Current consumption in Active Mode at pin VSD    | $I_{VSD}$                    | –      | –    | 40   | mA            | 20 kHz<br>PWM on Bridge Driver  | P_1.3.8  |
| Current consumption in Slow Down Mode            | $I_{SDM}$                    | –      | –    | 30   | mA            | $f_{\text{sys}} = 5 \text{ MHz}$ ; PWM communication running; charge pump on (reverse polarity FET on), external Low Side FET static on (motor break mode); VDDEXT on; all other module set to power down; $V_S = 13.5\text{V}$   | P_1.3.6  |
| Current consumption in Sleep Mode                | $I_{\text{Sleep}}$           | –      | 30   | 35   | $\mu\text{A}$ | System in Sleep Mode, microcontroller not powered, Wake capable via PWM interface and MON; MON connected to VS or GND;<br>GPIOs open (no loads) or connected to GND:<br>$T_j = -40^\circ\text{C to } 85^\circ\text{C}$ ;<br>$V_S = 5.5 \text{ V to } 18\text{V}$ ; <sup>2)</sup>  | P_1.3.3  |
| Current consumption in Sleep Mode extended range | $I_{\text{Sleep\_extended}}$ | –      | 90   | 200  | $\mu\text{A}$ | System in Sleep Mode, microcontroller not powered, Wake capable via PWM interface and MON; MON connected to VS or GND;<br>GPIOs open (no loads) or connected to GND:<br>$T_j = -40^\circ\text{C to } 150^\circ\text{C}$ ;<br>$V_S = 5.5 \text{ V to } 18\text{V}$ ; <sup>2)</sup> | P_1.3.15 |
| Current consumption in Sleep Mode                | $I_{\text{Sleep}}$           | –      | –    | 33   | $\mu\text{A}$ | System in Sleep Mode, microcontroller not powered, Wake capable via PWM interface and MON; MON connected to VS or GND;<br>GPIOs open (no loads) or connected to GND:<br>$T_j = -40^\circ\text{C to } 40^\circ\text{C}$ ;<br>$V_S = 5.5 \text{ V to } 18\text{V}$ ; <sup>2)</sup>  | P_1.3.9  |

**Electrical Characteristics**
**Table 19 Electrical Characteristics (cont'd)**

$V_S = 5.5 \text{ V to } 28 \text{ V}$ ,  $T_j = -40 \text{ }^\circ\text{C to } +150 \text{ }^\circ\text{C}$ ; all voltages with respect to ground, positive current flowing into pin (unless otherwise specified)

| Parameter   | Symbol                    | Values |      |      | Unit          | Note / Test Condition   | Number   |
|---|---------------------------|--------|------|------|---------------|---|----------|
|   |                           | Min.   | Typ. | Max. |               |   |          |
| Current consumption in Sleep Mode with cyclic wake            | $I_{\text{Cyclic}}$       | –      | –    | 110  | $\mu\text{A}$ | $T_j = -40^\circ\text{C to } 85^\circ\text{C}$ ;<br>$V_S = 5.5 \text{ V to } 18\text{V}$ ;<br>$t_{\text{Cyclic\_ON}} = 4\text{ms}$ ;<br>$t_{\text{Cyclic\_OFF}} = 2048 \text{ ms}$ ; <sup>2)</sup>  | P_1.3.4  |
| Current consumption in Stop Mode                              | $I_{\text{Stop}}$         | –      | 110  | 160  | $\mu\text{A}$ | System in Stop Mode, microcontroller not clocked, Wake capable via PWM interface and MON; MON connected to VS or GND; GPIOs open (no loads) or connected to GND; $T_j = -40^\circ\text{C to } 85^\circ\text{C}$ ;<br>$V_S = 5.5 \text{ V to } 18\text{V}$                         | P_1.3.10 |
| Current consumption in Stop Mode-Extended temperature range 1 | $I_{\text{Stop\_extend}}$ | –      | 600  | 1800 | $\mu\text{A}$ | System in Stop Mode, microcontroller not clocked, Wake capable via PWM interface and MON; MON connected to VS or GND; GPIOs open (no loads) or connected to GND;<br>$T_j = -40 \text{ }^\circ\text{C to } 150 \text{ }^\circ\text{C}$ ;<br>$V_S = 5.5 \text{ V to } 18 \text{ V}$ | P_1.3.20 |

1) Current on  $V_S$ , ADC1/2 active, timer running, PWM interface active (recessive).

2) Incl. leakage currents from VBAT\_SENSE, VDH, VSD and MON

*Note: Within the functional range, the IC operates as described in the circuit description. The electrical characteristics are specified within the conditions given in the related electrical characteristics table.*

### 29.1.4 Thermal Resistance

**Table 20 Thermal Resistance**

| Parameter                   | Symbol      | Values |      |      | Unit | Note / Test Condition                 | Number  |
|-----------------------------|-------------|--------|------|------|------|---------------------------------------|---------|
|                             |             | Min.   | Typ. | Max. |      |                                       |         |
| Junction to Soldering Point | $R_{thJSP}$ | –      | 6    | –    | K/W  | <sup>1)</sup> measured to Exposed Pad | P_1.4.1 |
| Junction to Ambient         | $R_{thJA}$  | –      | 33   | –    | K/W  | <sup>2)</sup>                         | P_1.4.2 |

1) Not subject to production test, specified by design.

2) According to Jedec JESD51-2,-5,-7 at natural convection on FR4 2s2p board. Board: 76.2x114.3x1.5mm<sup>3</sup> with 2 inner copper layers (35µm thick), with thermal via array under the exposed pad contacting the first inner copper layer and 300mm<sup>2</sup> cooling area on the bottom layer (70µm).

### 29.1.5 Timing Characteristics

The transition times between the system modes are specified here. Generally the timings are defined from the time when the corresponding bits in register PMCON0 are set until the sequence is terminated.

**Table 21 System Timing<sup>1)</sup>**

$V_S = 5.5\text{ V to }28\text{ V}$ ,  $T_j = -40\text{ °C to }+150\text{ °C}$ , all voltages with respect to ground, positive current flowing into pin (unless otherwise specified)

| Parameter            | Symbol              | Values |      |      | Unit | Note / Test Condition  | Number  |
|----------------------|---------------------|--------|------|------|------|--|---------|
|                      |                     | Min.   | Typ. | Max. |      |  |         |
| Wake-up over battery | $t_{start}$         | –      | –    | 3    | ms   | Battery ramp-up time to code execution   | P_1.5.6 |
| Wake-up over battery | $t_{startSW}$       | –      | –    | 1.5  | ms   | Battery ramp-up time to till MCU reset is released; $V_S > 3\text{ V}$ and RESET = 1       | P_1.5.1 |
| Sleep-Exit           | $t_{sleep - exit}$  | –      | –    | 1.5  | ms   | Rising/falling edge of any wake-up signal (PWM interface, MON) till MCU reset is released; | P_1.5.2 |
| Sleep-Entry          | $t_{sleep - entry}$ | –      | –    | 330  | µs   | <sup>2)</sup>  | P_1.5.3 |

1) Not subject to production test, specified by design.

2) Wake events during Sleep-Entry are stored and lead to wake-up after Sleep Mode is reached.

## 29.2 Power Management Unit (PMU)

This chapter includes all electrical characteristics of the Power Management Unit

### 29.2.1 PMU I/O Supply (VDDP) Parameters

This chapter describes all electrical parameters which are observable on SoC level. For this purpose only the pad-supply VDDP and the transition times between the system modes are specified here.

**Table 22 Electrical Characteristics**

$V_S = 5.5\text{ V to }28\text{ V}$ ,  $T_j = -40\text{ °C to }+150\text{ °C}$ , all voltages with respect to ground, positive current flowing into pin (unless otherwise specified)

| Parameter   | Symbol                 | Values |      |       | Unit          | Note / Test Condition  | Number   |
|---|------------------------|--------|------|-------|---------------|--|----------|
|   |                        | Min.   | Typ. | Max.  |               |  |          |
| Specified output current  | $I_{VDDP}$             | 0      | –    | 50    | mA            | <sup>1)</sup>  | P_2.1.1  |
| Specified output current  | $I_{VDDP}$             | 0      | –    | 30    | mA            | <sup>1)2)</sup>  | P_2.1.22 |
| Required decoupling capacitance                                 | $C_{VDDP1}$            | 0.47   | –    | 2.2   | $\mu\text{F}$ | <sup>3)4)</sup> ESR < 1 $\Omega$ ; the specified capacitor value is a typical value. | P_2.1.2  |
| Required buffer capacitance for stability (load jumps)          | $C_{VDDP2}$            | 1      | –    | 2.2   | $\mu\text{F}$ | <sup>3)4)</sup> The specified capacitor value is a typical value.                    | P_2.1.20 |
| Output voltage including line and load regulation @ Active Mode | $V_{DDPOUT}$           | 4.9    | 5.0  | 5.1   | V             | <sup>5)</sup> $I_{load} < 90\text{mA}$ ; $V_S > 5.5\text{V}$                         | P_2.1.3  |
| Output voltage including line and load regulation @ Active Mode | $V_{DDPOUT}$           | 4.9    | 5.0  | 5.1   | V             | <sup>2)5)</sup> $I_{load} < 70\text{mA}$ ; $V_S > 5.5\text{V}$                       | P_2.1.23 |
| Output voltage including line and load regulation @ Stop Mode   | $V_{DDPOUTS}$<br>TOP   | 4.5    | 5.0  | 5.5   | V             | <sup>5)</sup> $I_{load}$ is only internal; $V_S > 5.5\text{V}$                       | P_2.1.21 |
| Output drop @ Active Mode                                       | $V_{SVDDPout}$         | –      | 50   | 400   | mV            | $I_{VDDP} = 30\text{mA}^6)$ ;<br>$3.5\text{V} < V_S < 5.0\text{V}$                   | P_2.1.4  |
| Load regulation @ Active Mode                                   | $V_{VDDPLOR}$          | -50    | –    | 50    | mV            | 2 ... 90mA; $C = 570\text{nF}$   | P_2.1.5  |
| Line regulation @ Active Mode                                   | $V_{VDDPLIR}$          | -50    | –    | 50    | mV            | $V_S = 5.5 \dots 28\text{V}$   | P_2.1.6  |
| Overvoltage detection   | $V_{DDPOV}$            | 5.14   | –    | 5.4   | V             | $V_S > 5.5\text{V}$ ; Overvoltage leads to SUPPLY_NMI                                | P_2.1.7  |
| Overvoltage detection filter time                               | $t_{FILT\_VDDP}$<br>OV | –      | 735  | –     | $\mu\text{s}$ | <sup>3)7)</sup>  | P_2.1.24 |
| Voltage OK detection  | $V_{DDPOK}$            | –      | 3    | –     | V             | <sup>3)</sup>  | P_2.1.25 |
| Voltage stable detection range <sup>8)</sup>                    | $\Delta V_{DDPSTB}$    | - 220  | –    | + 220 | mV            | <sup>3)</sup>  | P_2.1.26 |
| Undervoltage reset  | $V_{DDPUV}$            | 2.5    | 2.6  | 2.7   | V             | –  | P_2.1.8  |
| Overcurrent diagnostic  | $I_{VDDPOC}$           | 91     | –    | 220   | mA            | –  | P_2.1.9  |

**Table 22 Electrical Characteristics (cont'd)**

$V_S = 5.5\text{ V to }28\text{ V}$ ,  $T_j = -40\text{ °C to }+150\text{ °C}$ , all voltages with respect to ground, positive current flowing into pin (unless otherwise specified)

| Parameter                            | Symbol                           | Values |      |      | Unit          | Note / Test Condition | Number   |
|--------------------------------------|----------------------------------|--------|------|------|---------------|-----------------------|----------|
|                                      |                                  | Min.   | Typ. | Max. |               |                       |          |
| Overcurrent diagnostic filter time   | $t_{\text{FILT\_VDDP}}$<br>OC    | –      | 27   | –    | $\mu\text{s}$ | <sup>3)7)</sup>       | P_2.1.27 |
| Overcurrent diagnostic shutdown time | $t_{\text{FILT\_VDDP}}$<br>OC_SD | –      | 290  | –    | $\mu\text{s}$ | <sup>3)7)9)</sup>     | P_2.1.28 |

- 1) Specified output current for port supply and additional other external loads already excluding VDDC current.
- 2) This use case applies to cases where output current on VDDEXT is max. 40 mA.
- 3) Not subject to production test, specified by design.
- 4) Ceramic capacitor.
- 5) Load current includes internal supply.
- 6) Output drop for IVDDP without internal supply current.
- 7) This filter time and its variation is derived from the time base  $t_{\text{LP\_CLK}} = 1 / f_{\text{LP\_CLK}}$ .
- 8) The absolute voltage value is the sum of parameters  $V_{\text{DDP}} + \Delta V_{\text{DDPSTB}}$ .
- 9) After  $t_{\text{FILT\_VDDCOC\_SD}}$  is passed and the overcurrent condition is still present, the device will enter sleep mode.



## 29.2.2 PMU Core Supply (VDDC) Parameters

This chapter describes all electrical parameters which are observable on SoC level. For this purpose only the core-supply VDDC and the transition times between the system modes are specified here.

**Table 23 Electrical Characteristics**

$V_S = 5.5\text{ V to }28\text{ V}$ ,  $T_j = -40\text{ °C to }+150\text{ °C}$ , all voltages with respect to ground, positive current flowing into pin (unless otherwise specified)

| Parameter  | Symbol                   | Values |      |       | Unit | Note / Test Condition   | Number   |
|--|--------------------------|--------|------|-------|------|---|----------|
|  |                          | Min.   | Typ. | Max.  |      |   |          |
| Required decoupling capacitance                              | $C_{VDDC1}$              | 0.1    | –    | 1     | μF   | <sup>1)2)</sup> ESR < 1Ω; the specified capacitor value is a typical value. | P_2.2.1  |
| Required buffer capacitance for stability (load jumps)       | $C_{VDDC2}$              | 0.33   | –    | 1     | μF   | <sup>2)</sup> the specified capacitor value is a typical value.             | P_2.2.17 |
| Output voltage including line regulation @ Active Mode       | $V_{DDCOUT}$             | 1.44   | 1.5  | 1.56  | V    | $I_{load} < 40\text{mA}$  | P_2.2.2  |
| Reduced output voltage including line regulation @ Stop Mode | $V_{DDCOUT\_Stop\_Red}$  | 0.95   | 1.1  | 1.3   | V    | with internal VDDC load only: $I_{load\_internal} < 1.5\text{mA}$           | P_2.2.23 |
| Load Regulation @ Active Mode                                | $V_{DDCLOR}$             | -50    | –    | 50    | mV   | 2 ... 40mA; C =430nF  | P_2.2.3  |
| Line regulation @ Active Mode                                | $V_{DDCLIR}$             | -25    | –    | 25    | mV   | $V_{DDP} = 2.5 \dots 5.5\text{V}$   | P_2.2.4  |
| Overvoltage detection  | $V_{DDCOV}$              | 1.59   | 1.62 | 1.68  | V    | Overvoltage leads to SUPPLY_NMI   | P_2.2.5  |
| Overvoltage detection filter time                            | $t_{FILT\_VDDC\ OV}$     | –      | 735  | –     | μs   | <sup>1)3)</sup>   | P_2.2.18 |
| Voltage OK detection range <sup>4)</sup>                     | $\Delta V_{DDCOK}$       | - 280  | –    | + 280 | mV   | <sup>1)</sup>   | P_2.2.19 |
| Voltage stable detection range <sup>5)</sup>                 | $\Delta V_{DDCSTB}$      | - 110  | –    | + 110 | mV   | <sup>1)</sup>   | P_2.2.20 |
| Undervoltage reset   | $V_{DDVUV}$              | 1.136  | 1.20 | 1.264 | V    | –   | P_2.2.6  |
| Overcurrent diagnostic                                       | $I_{VDDCOC}$             | 45     | –    | 100   | mA   | –   | P_2.2.7  |
| Overcurrent diagnostic filter time                           | $t_{FILT\_VDDC\ OC}$     | –      | 27   | –     | μs   | <sup>1)3)</sup>   | P_2.2.21 |
| Overcurrent diagnostic shutdown time                         | $t_{FILT\_VDDC\ OC\_SD}$ | –      | 290  | –     | μs   | <sup>1)3)6)</sup>   | P_2.2.22 |

1) Not subject to production test, specified by design.

2) Ceramic capacitor.

3) This filter time and its variation is derived from the time base  $t_{LP\_CLK} = 1 / f_{LP\_CLK}$ .

4) The absolute voltage value is the sum of parameters  $V_{DDC} + \Delta V_{DDCSTB}$ .

5) The absolute voltage value is the sum of parameters  $V_{DDC} + \Delta V_{DDCOK}$ .

6) After  $t_{FILT\_VDDCOC\_SD}$  is passed and the overcurrent condition is still present the device will enter sleep mode.

**29.2.3 VDDEXT Voltage Regulator (5.0V) Parameters**
**Table 24 Electrical Characteristics**
 $V_S = 5.5\text{ V to }28\text{ V}$ ,  $T_j = -40\text{ °C to }+150\text{ °C}$ , all voltages with respect to ground, positive current flowing into pin (unless otherwise specified)

| Parameter  | Symbol                 | Values |      |       | Unit          | Note / Test Condition   | Number   |
|--|------------------------|--------|------|-------|---------------|---|----------|
|  |                        | Min.   | Typ. | Max.  |               |   |          |
| Specified output current                               | $I_{VDDEXT}$           | 0      | –    | 20    | mA            | –   | P_2.3.1  |
| Specified output current                               | $I_{VDDEXT}$           | 0      | –    | 40    | mA            | <sup>1)</sup>   | P_2.3.21 |
| Required decoupling capacitance                        | $C_{VDDEXT1}$          | 0.1    | –    | 2.2   | $\mu\text{F}$ | <sup>3) 2)</sup> ESR < 1 $\Omega$ ; the specified capacitor value is a typical value. | P_2.3.22 |
| Required buffer capacitance for stability (load jumps) | $C_{VDDEXT2}$          | 1      | –    | 2.2   | $\mu\text{F}$ | <sup>3)2)</sup> the specified capacitor value is a typical value.                     | P_2.3.20 |
| Output voltage including line and load regulation      | $V_{DDEXT}$            | 4.9    | 5.0  | 5.1   | V             | <sup>3)</sup> $I_{load} < 20\text{mA}$ ; $V_S > 5.5\text{V}$                          | P_2.3.3  |
| Output voltage including line and load regulation      | $V_{DDEXT}$            | 4.8    | 5.0  | 5.2   | V             | $I_{load} < 40\text{mA}$ ; $V_S > 5.5\text{V}$  | P_2.3.23 |
| Output drop @ Active Mode                              | $V_S - V_{DDEXT}$      |        | 50   | +300  | mV            | <sup>3)</sup> $I_{load} < 20\text{mA}$ ; $3\text{V} < V_S < 5.0\text{V}$              | P_2.3.4  |
| Output drop @ Active Mode                              | $V_S - V_{DDEXT}$      |        | –    | +400  | mV            | $I_{load} < 40\text{mA}$ ; $3\text{V} < V_S < 5.0\text{V}$                            | P_2.3.14 |
| Load regulation @ Active Mode                          | $V_{DDEXTLOR}$         | -50    | –    | 50    | mV            | 2 ... 40mA; $C = 200\text{nF}$  | P_2.3.5  |
| Line regulation @ Active Mode                          | $V_{VDDEXTLIR}$        | -50    | –    | 50    | mV            | $V_S = 5.5 \dots 28\text{V}$  | P_2.3.6  |
| Power supply ripple rejection @ Active Mode            | $P_{SSRVDDEXT}$        | 50     | –    | –     | dB            | <sup>3)</sup> $V_S = 13.5\text{V}$ ; $f = 0 \dots 1\text{KHz}$ ; $V_r = 2\text{Vpp}$  | P_2.3.7  |
| Overvoltage detection                                  | $V_{VDDEXTOV}$         | 5.18   | –    | 5.4   | V             | $V_S > 5.5\text{V}$   | P_2.3.8  |
| Overvoltage detection filter time                      | $t_{FILT\_VDDEXTOV}$   | –      | 735  | –     | $\mu\text{s}$ | <sup>3)4)</sup>   | P_2.3.24 |
| Voltage OK detection range                             | $V_{VDDEXTOK}$         | –      | 3    | –     | V             | <sup>3)</sup>   | P_2.3.25 |
| Voltage stable detection range <sup>5)</sup>           | $\Delta V_{VDDEXTSTB}$ | - 220  | –    | + 220 | mV            | <sup>3)</sup>   | P_2.3.26 |
| Undervoltage trigger                                   | $V_{VDDEXTUV}$         | 2.6    | 2.8  | 3.0   | V             | <sup>6)</sup>   | P_2.3.9  |
| Overcurrent diagnostic                                 | $I_{VDDEXTOC}$         | 50     | –    | 160   | mA            | –   | P_2.3.10 |
| Overcurrent diagnostic filter time                     | $t_{FILT\_VDDCOC}$     | –      | 27   | –     | $\mu\text{s}$ | <sup>3)4)</sup>   | P_2.3.27 |
| Overcurrent diagnostic shutdown time                   | $t_{FILT\_VDDCOC\_SD}$ | –      | 290  | –     | $\mu\text{s}$ | <sup>3)4)</sup>   | P_2.3.28 |

1) This use case requires the reduced utilization of VDDP output current by 20 mA, see P\_2.1.22.

2) Ceramic capacitor.

3) Not subject to production test, specified by design.

4) This filter time and its variation is derived from the time base  $t_{LP\_CLK} = 1 / f_{LP\_CLK}$ .

---

**Electrical Characteristics**

- 5) The absolute voltage value is the sum of parameters  $V_{\text{DDEXT}} + \Delta V_{\text{DDEXTSTB}}$ .
- 6) When the condition is met, the Bit VDDEXT\_CTRL.bit.SHORT will be set.

### 29.2.4 VPRE Voltage Regulator (PMU Subblock) Parameters

The PMU VPRE Regulator acts as a supply of VDDP and VDDEXT voltage regulators.

**Table 25 Functional Range**

| Parameter                | Symbol     | Values |      |      | Unit | Note / Test Condition | Number  |
|--------------------------|------------|--------|------|------|------|-----------------------|---------|
|                          |            | Min.   | Typ. | Max. |      |                       |         |
| Specified output current | $I_{VPRE}$ | –      | –    | 110  | mA   | 1)                    | P_2.4.1 |

1) Not subject to production test, specified by design.

#### 29.2.4.1 Load Sharing Scenarios of VPRE Regulator

The figure below shows the possible load sharing scenarios of VPRE regulator.

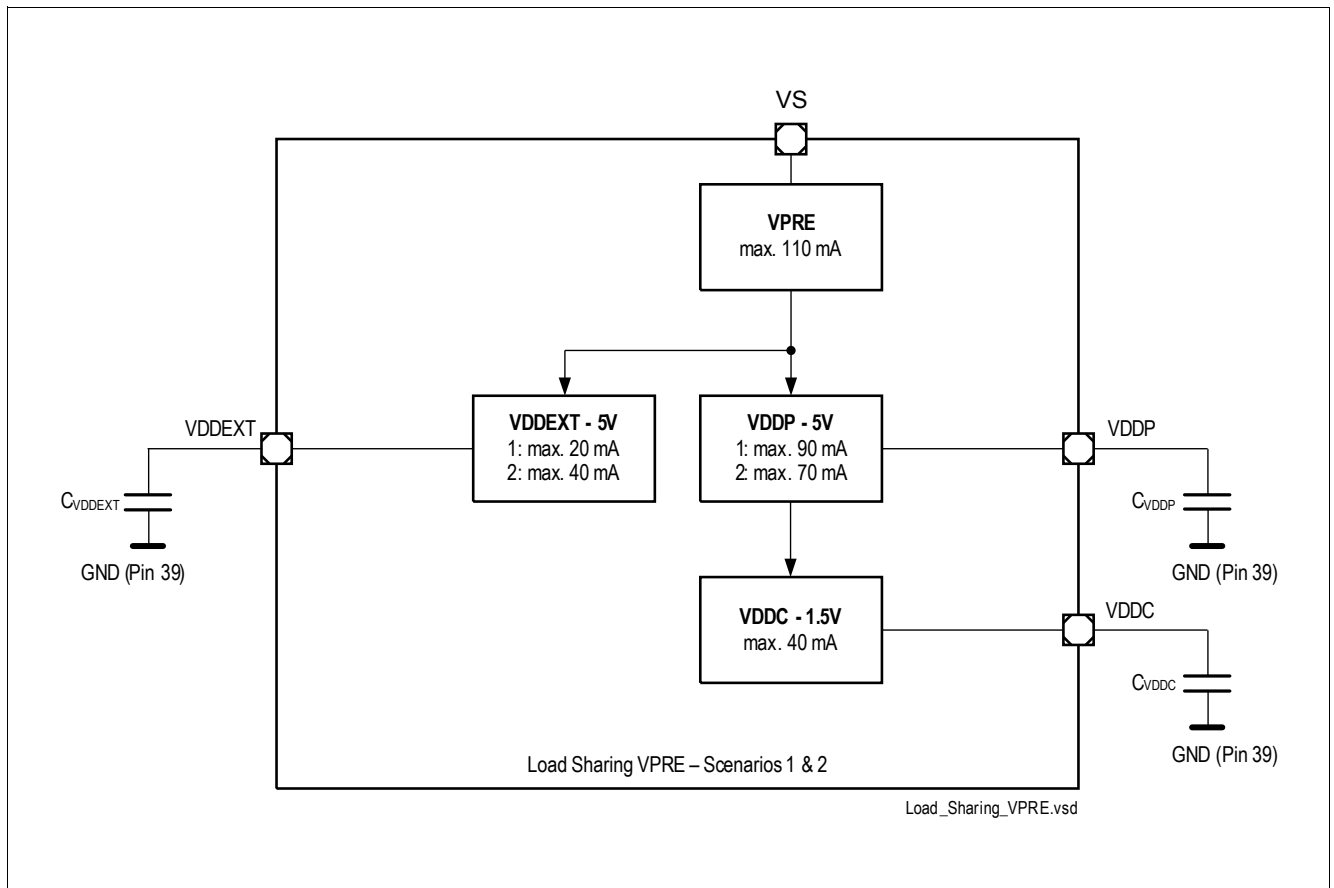

**Figure 32 Load Sharing Scenarios of VPRE Regulator**

### 29.2.5 Power Down Voltage Regulator (PMU Subblock) Parameters

The PMU Power Down voltage regulator consists of two subblocks:

- Power Down Pre regulator: VDD5VPD
- Power Down Core regulator: VDD1V5\_PD (Supply used for GPUDATAx registers)

Both regulators are used as purely internal supplies. The following table contains all relevant parameters:

**Table 26 Functional Range**

| Parameter                | Symbol                 | Values |      |      | Unit | Note / Test Condition | Number  |
|--------------------------|------------------------|--------|------|------|------|-----------------------|---------|
|                          |                        | Min.   | Typ. | Max. |      |                       |         |
| <b>VDD1V5_PD</b>         |                        |        |      |      |      |                       |         |
| Power-On Reset Threshold | $V_{DD1V5\_PD\_RSTTH}$ | 1.2    | –    | 1.5  | V    | <sup>1)</sup>         | P_2.5.1 |

1) Not subject to production test, specified by design

## 29.3 System Clocks

### 29.3.1 Oscillators and PLL Parameters

**Table 27 Electrical Characteristics System Clocks**

$V_S = 5.5\text{ V to }28\text{ V}$ ,  $T_j = -40\text{ °C to }+150\text{ °C}$ , all voltages with respect to ground, positive current flowing into pin (unless otherwise specified)

| Parameter  | Symbol          | Values  |      |      | Unit | Note / Test Condition  | Number   |
|--|-----------------|---------|------|------|------|--|----------|
|  |                 | Min.    | Typ. | Max. |      |  |          |
| <b>PMU Oscillators (Power Management Unit)</b>                   |                 |         |      |      |      |  |          |
| Frequency of LP_CLK  | $f_{LP\_CLK}$   | 14      | 18   | 22   | MHz  | This clock is used at startup and can be used in case the PLL fails  | P_3.1.1  |
| Frequency of LP_CLK2   | $f_{LP\_CLK2}$  | 70      | 100  | 130  | kHz  | This clock is used for cyclic wake   | P_3.1.2  |
| <b>CGU Oscillator (Clock Generation Unit Microcontroller)</b>    |                 |         |      |      |      |  |          |
| Short term frequency deviation <sup>1)</sup>                     | $f_{TRIMST}$    | -0.4    | –    | +0.4 | %    | <sup>2)3)</sup> Within any 10 ms, e.g. after synchronization to a PWM signal (PLL settings untouched within 10 ms) | P_3.1.3  |
| Absolute accuracy  | $f_{TRIMABSA}$  | -1.5    | –    | +1.5 | %    | Including temperature and lifetime deviation   | P_3.1.4  |
| CGU-OSC Start-up time  | $t_{OSC}$       | –       | –    | 10   | µs   | <sup>3)</sup> Startup time OSC from Sleep Mode, power supply stable  | P_3.1.5  |
| <b>PLL (Clock Generation Unit Microcontroller) <sup>3)</sup></b> |                 |         |      |      |      |  |          |
| VCO frequency range Mode 0                                       | $f_{VCO-0}$     | 48      | –    | 112  | MHz  | VCOSEL ="0"  | P_3.1.6  |
| VCO frequency range Mode 1                                       | $f_{VCO-1}$     | 96      | –    | 160  | MHz  | VCOSEL ="1"  | P_3.1.7  |
| Input frequency range  | $f_{OSC}$       | 4       | –    | 16   | MHz  | –  | P_3.1.8  |
| XTAL1 input freq. range  | $f_{OSC}$       | 4       | –    | 16   | MHz  | –  | P_3.1.9  |
| Output freq. range   | $f_{PLL}$       | 0.04687 | –    | 80   | MHz  | –  | P_3.1.10 |
| Free-running frequency Mode 0                                    | $f_{VCOfree_0}$ | –       | –    | 38   | MHz  | VCOSEL ="0"  | P_3.1.11 |
| Free-running frequency Mode 1                                    | $f_{VCOfree_1}$ | –       | –    | 76   | MHz  | VCOSEL ="1"  | P_3.1.12 |
| Input clock high/low time  | $t_{high/low}$  | 10      | –    | –    | ns   | –  | P_3.1.13 |
| Peak period jitter   | $t_{jp}$        | -500    | –    | 500  | ps   | <sup>4)</sup> for K=1  | P_3.1.14 |
| Accumulated jitter   | jacc            | –       | –    | 5    | ns   | <sup>4)</sup> for K=1  | P_3.1.15 |
| Lock-in time   | $t_L$           | –       | –    | 200  | µs   | –  | P_3.1.16 |

- 1) The typical oscillator frequency is 5 MHz
- 2)  $V_{DDC} = 1.5 \text{ V}$ ,  $T_j = 25^\circ\text{C}$
- 3) Not subject to production test, specified by design.
- 4) This parameter is valid for PLL operation with an external clock source and thus reflects the real PLL performance.

### 29.3.2 External Clock Parameters XTAL1, XTAL2

**Table 28 Functional Range**

$V_S = 5.5 \text{ V to } 28 \text{ V}$ ,  $T_j = -40^\circ\text{C to } +150^\circ\text{C}$ , all voltages with respect to ground, positive current flowing into pin (unless otherwise specified)<sup>1)</sup>

| Parameter                                      | Symbol        | Values               |      |          | Unit          | Note / Test Condition              | Number  |
|--|---------------|----------------------|------|----------|---------------|------------------------------------|---------|
|  |               | Min.                 | Typ. | Max.     |               |                                    |         |
| Input voltage range limits for signal on XTAL1 | $V_{IX1\_SR}$ | $-1.7 + V_{DDC}$     | –    | 1.7      | V             | <sup>2)</sup>                      | P_3.2.1 |
| Input voltage (amplitude) on XTAL1             | $V_{AX1\_SR}$ | $0.3 \times V_{DDC}$ | –    | –        | V             | <sup>3)</sup> Peak-to-peak voltage | P_3.2.2 |
| XTAL1 input current                            | $I_{IL}$      | –                    | –    | $\pm 20$ | $\mu\text{A}$ | $0 \text{ V} < V_{IN} < V_{DDI}$   | P_3.2.3 |
| Oscillator frequency                           | $f_{OSC}$     | 4                    | –    | 24       | MHz           | Clock signal                       | P_3.2.4 |
| Oscillator frequency                           | $f_{OSC}$     | 4                    | –    | 16       | MHz           | Crystal or Resonator               | P_3.2.5 |
| High time                                      | $t_1$         | 6                    | –    | –        | ns            | –                                  | P_3.2.6 |
| Low time                                       | $t_2$         | 6                    | –    | –        | ns            | –                                  | P_3.2.7 |
| Rise time                                      | $t_3$         | –                    | 8    | 8        | ns            | –                                  | P_3.2.8 |
| Fall time                                      | $t_4$         | –                    | 8    | 8        | ns            | –                                  | P_3.2.9 |

- 1) This parameter table is not subject to production test, specified by design.
- 2) Overload conditions must not occur on pin XTAL1.
- 3) The amplitude voltage  $V_{AX1}$  refers to the offset voltage  $V_{OFF}$ . This offset voltage must be stable during the operation and the resulting voltage peaks must remain within the limits defined by  $V_{IX1}$ .

## 29.4 Flash Memory

This chapter includes the parameters for the 36 kByte embedded flash module.

### 29.4.1 Flash Parameters

**Table 29 Flash Characteristics<sup>1)</sup>**

$V_S = 3.0\text{ V to }28\text{ V}$ ,  $T_j = -40\text{ °C to }+150\text{ °C}$ , all voltages with respect to ground, positive current flowing into pin (unless otherwise specified)

| Parameter                                | Symbol    | Values |                 |      | Unit    | Note / Test Condition   | Number  |
|--|-----------|--------|-----------------|------|---------|---|---------|
|  |           | Min.   | Typ.            | Max. |         |   |         |
| Programming time per 128 byte page       | $t_{PR}$  | –      | 3 <sup>2)</sup> | 3.5  | ms      | $3\text{V} < V_S < 28\text{V}$                                    | P_4.1.1 |
| Erase time per sector/page               | $t_{ER}$  | –      | 4 <sup>2)</sup> | 4.5  | ms      | $3\text{V} < V_S < 28\text{V}$                                    | P_4.1.2 |
| Data retention time                      | $t_{RET}$ | 20     | –               | –    | years   | 1,000 erase / program cycles                                      | P_4.1.3 |
| Data retention time                      | $t_{RET}$ | 50     | –               | –    | years   | 1,000 erase / program cycles<br>$T_j = 30\text{°C}$ <sup>3)</sup> | P_4.1.9 |
| Flash erase endurance for user sectors   | $N_{ER}$  | 30     | –               | –    | kcycles | Data retention time 5 years                                       | P_4.1.4 |
| Flash erase endurance for security pages | $N_{SEC}$ | 10     | –               | –    | cycles  | <sup>4)</sup> Data retention time 20 years                        | P_4.1.5 |
| Drain disturb limit                      | $N_{DD}$  | 32     | –               | –    | kcycles | <sup>5)</sup>   | P_4.1.6 |

1) Not subject for production test, specified by design.

2) Programming and erase times depend on the internal Flash clock source. The control state machine needs a few system clock cycles. The requirement is only relevant for extremely low system frequencies.

3) Derived by extrapolation of lifetime tests.

4)  $T_j = 25\text{ °C}$ .

5) This parameter limits the number of subsequent programming operations within a physical sector without a given page in this sector being (re-)programmed. The drain disturb limit is applicable if wordline erase is used repeatedly. For normal sector erase/program cycles this limit will not be violated. For data sectors the integrated EEPROM emulation firmware routines handle this limit automatically, for wordline erases in code sectors (without EEPROM emulation) it is recommended to execute a software based refresh, which may make use of the integrated random number generator NVMBRNG to statistically start a refresh.



## 29.5 Parallel Ports (GPIO)

### 29.5.1 Description of Keep and Force Current

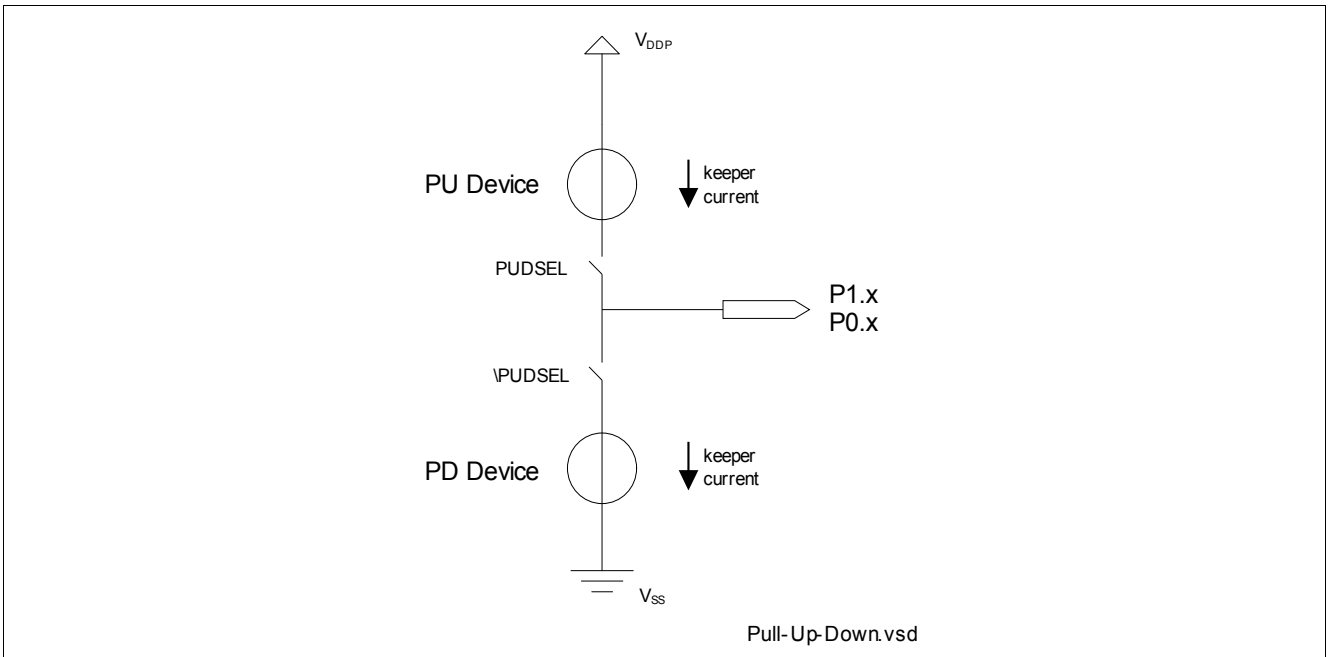

Figure 33 Pull-Up/Down Device

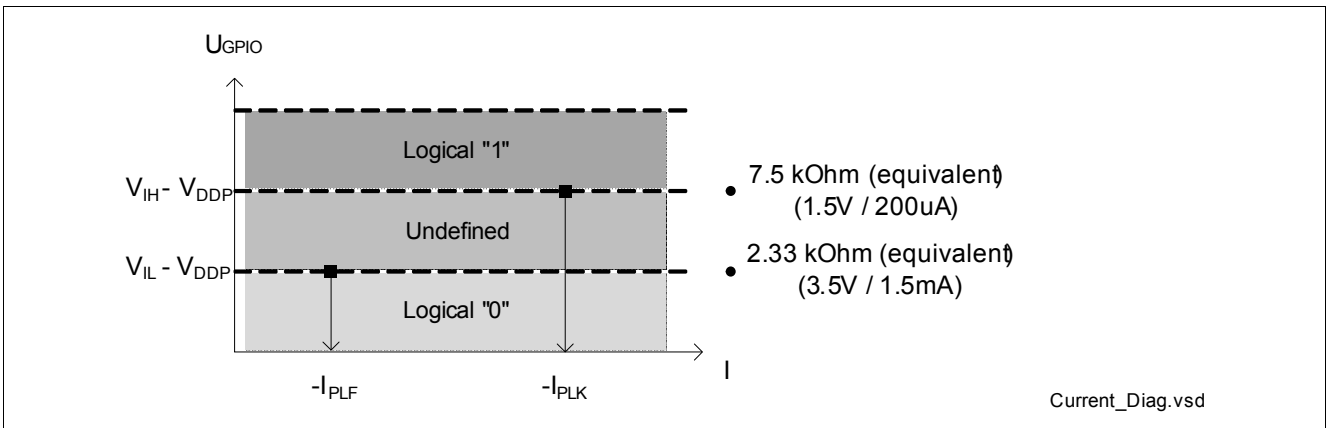

Figure 34 Pull-Up Keep and Forced Current

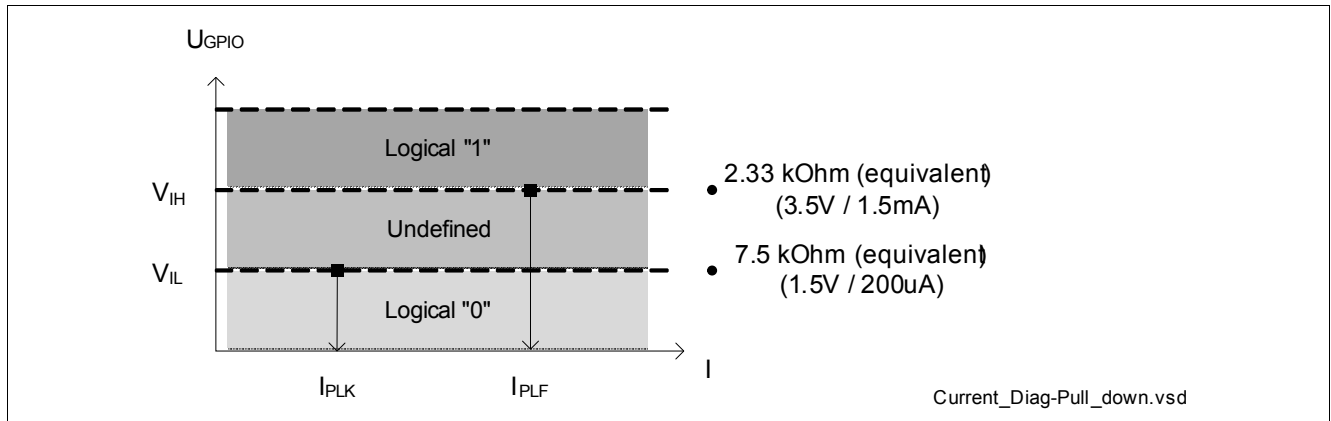

Figure 35 Pull-Down Keep and Force Current

### 29.5.2 DC Parameters of Port 0, Port 1, TMS and Reset

Note: Operating Conditions apply.

Keeping signal levels within the limits specified in this table ensures operation without overload conditions. For signal levels outside these specifications, also refer to the specification of the maximum allowed current which can be taken out of VDDP.

Table 30 Current Limits for Port Output Drivers<sup>1)</sup>

| Port Output Driver Mode     | Maximum Output Current ( $I_{OLmax}$ , - $I_{OHmax}$ ) |                         | Maximum Output Current ( $I_{OLnom}$ , - $I_{OHnom}$ ) |                         | Number   |
|-----------------------------|--|-------------------------|--|-------------------------|----------|
|                             | $V_{DDP} \geq 4.5V$                                    | $2.6V < V_{DDP} < 4.5V$ | $V_{DDP} \geq 4.5V$                                    | $2.6V < V_{DDP} < 4.5V$ |          |
| Strong driver <sup>2)</sup> | 5 mA   | 3 mA                    | 1.6 mA   | 1.0 mA                  | P_5.1.15 |
| Medium driver <sup>3)</sup> | 3 mA   | 1.8 mA                  | 1.0 mA   | 0.8 mA                  | P_5.1.1  |
| Weak driver <sup>3)</sup>   | 0.5 mA   | 0.3 mA                  | 0.25 mA  | 0.15 mA                 | P_5.1.2  |

- 1) Not subject to production test, specified by design.
- 2) Not available for port pins P0.4, P1.0, P1.1 and P1.2
- 3) All P0.x and P1.x

Table 31 DC Characteristics Port0, Port1

$V_S = 5.5 V$  to  $28 V$ ,  $T_j = -40 \text{ }^\circ\text{C}$  to  $+150 \text{ }^\circ\text{C}$ , all voltages with respect to ground, positive current flowing into pin (unless otherwise specified)

| Parameter        | Symbol                 | Values                |                       |      | Unit | Note / Test Condition   | Number   |
|------------------|------------------------|-----------------------|-----------------------|------|------|---|----------|
|                  |                        | Min.                  | Typ.                  | Max. |      |   |          |
| Input hysteresis | $HYS_{P0\_P1}$         | $0.11 \times V_{DDP}$ | –                     | –    | V    | <sup>1)</sup> Series resistance = $0 \text{ } \Omega$ ; $4.5V \leq V_{DDP} \leq 5.5V$ | P_5.1.5  |
| Input hysteresis | $HYS_{P0\_P1\_extend}$ | –                     | $0.09 \times V_{DDP}$ | –    | V    | <sup>1)</sup> Series resistance = $0 \text{ } \Omega$ ; $2.6V \leq V_{DDP} \leq 4.5V$ | P_5.1.16 |

**Electrical Characteristics**
**Table 31 DC Characteristics Port0, Port1 (cont'd)**
 $V_S = 5.5\text{ V to }28\text{ V}$ ,  $T_j = -40\text{ °C to }+150\text{ °C}$ , all voltages with respect to ground, positive current flowing into pin (unless otherwise specified)

| Parameter                | Symbol            | Values               |                       |                      | Unit          | Note / Test Condition  | Number   |
|--------------------------|-------------------|----------------------|-----------------------|----------------------|---------------|--|----------|
|                          |                   | Min.                 | Typ.                  | Max.                 |               |  |          |
| Input low voltage        | $V_{IL}$          | -0.3                 | –                     | $0.3 \times V_{DDP}$ | V             | <sup>2)</sup> $4.5\text{V} \leq V_{DDP} \leq 5.5\text{V}$                                  | P_5.1.3  |
| Input low voltage        | $V_{IL\_extend}$  | -0.3                 | $0.42 \times V_{DDP}$ | –                    | V             | <sup>1)</sup> $2.6\text{V} \leq V_{DDP} \leq 4.5\text{V}$                                  | P_5.1.17 |
| Input high voltage       | $V_{IH}$          | $0.7 \times V_{DDP}$ | –                     | $V_{DDP} + 0.3$      | V             | <sup>2)</sup> $4.5\text{V} \leq V_{DDP} \leq 5.5\text{V}$                                  | P_5.1.4  |
| Input high voltage       | $V_{IH\_extend}$  | –                    | $0.52 \times V_{DDP}$ | $V_{DDP} + 0.3$      | V             | <sup>1)</sup> $2.6\text{V} \leq V_{DDP} \leq 4.5\text{V}$                                  | P_5.1.18 |
| Output low voltage       | $V_{OL}$          | –                    | –                     | 1.0                  | V             | <sup>3) 4)</sup> $I_{OL} \leq I_{OLmax}$   | P_5.1.6  |
| Output low voltage       | $V_{OL}$          | –                    | –                     | 0.4                  | V             | <sup>3) 5)</sup> $I_{OL} \leq I_{OLnom}$   | P_5.1.7  |
| Output high voltage      | $V_{OH}$          | $V_{DDP} - 1.0$      | –                     | –                    | V             | <sup>3) 4)</sup> $I_{OH} \geq I_{OHmax}$   | P_5.1.8  |
| Output high voltage      | $V_{OH}$          | $V_{DDP} - 0.4$      | –                     | –                    | V             | <sup>3) 5)</sup> $I_{OH} \geq I_{OHnom}$   | P_5.1.9  |
| Input leakage current    | $I_{OZ\_extend1}$ | -500                 | –                     | +500                 | nA            | $-40\text{°C} \leq T_j \leq 25\text{°C}$ ,<br>$0.45\text{ V} < V_{IN} < V_{DDP}$           | P_5.1.20 |
| Input leakage current    | $I_{OZ1}$         | -5                   | –                     | +5                   | $\mu\text{A}$ | <sup>6)</sup> $25\text{°C} < T_j \leq 85\text{°C}$ ,<br>$0.45\text{ V} < V_{IN} < V_{DDP}$ | P_5.1.10 |
| Input leakage current    | $I_{OZ\_extend2}$ | -15                  | –                     | +15                  | $\mu\text{A}$ | $85\text{°C} < T_j \leq 150\text{°C}$ ,<br>$0.45\text{ V} < V_{IN} < V_{DDP}$              | P_5.1.11 |
| Pull level keep current  | $I_{PLK}$         | -200                 | –                     | +200                 | $\mu\text{A}$ | <sup>7)</sup> $V_{PIN} \geq V_{IH}$ (up)<br>$V_{PIN} \leq V_{IL}$ (dn)                     | P_5.1.12 |
| Pull level force current | $I_{PLF}$         | -1.5                 | –                     | +1.5                 | mA            | <sup>7)</sup> $V_{PIN} \leq V_{IL}$ (up)<br>$V_{PIN} \geq V_{IH}$ (dn)                     | P_5.1.13 |
| Pin capacitance          | $C_{IO}$          | –                    | –                     | 10                   | pF            | <sup>1)</sup>  | P_5.1.14 |

**Reset Pin Timing**

|                             |                   |   |   |   |               |               |          |
|-----------------------------|-------------------|---|---|---|---------------|---------------|----------|
| Reset Pin Input Filter Time | $t_{filt\_RESET}$ | – | 5 | – | $\mu\text{s}$ | <sup>1)</sup> | P_5.1.19 |
|-----------------------------|-------------------|---|---|---|---------------|---------------|----------|

- 1) Not subject to production test, specified by design.
- 2) Tested at  $V_{DDP} = 5\text{V}$ , specified for  $4.5\text{V} < V_{DDP} < 5.5\text{V}$ .
- 3) The maximum deliverable output current of a port driver depends on the selected output driver mode. The limit for pin groups must be respected.
- 4) Tested at  $4.9\text{V} < V_{DDP} < 5.1\text{V}$ ,  $I_{OL} = 4\text{mA}$ ,  $I_{OH} = -4\text{mA}$ , specified for  $4.5\text{V} < V_{DDP} < 5.5\text{V}$ .
- 5) As a rule, with decreasing output current the output levels approach the respective supply level ( $V_{OL} \rightarrow GND$ ,  $V_{OH} \rightarrow V_{DDP}$ ). Tested at  $4.9\text{V} < V_{DDP} < 5.1\text{V}$ ,  $I_{OL} = 1\text{mA}$ ,  $I_{OH} = -1\text{mA}$ .

**Electrical Characteristics**

- 6) The given values are worst-case values. In production tests, this leakage current is only tested at 150°C; other values are ensured by correlation. For derating, please refer to the following descriptions:

Leakage derating depending on temperature ( $T_J$  = junction temperature [°C]):

$$I_{OZ} = 0.05 \times e^{(1.5 + 0.028 \times T_J)} \text{ [}\mu\text{A]}. \text{ For example, at a temperature of } 95^\circ\text{C} \text{ the resulting leakage current is } 3.2 \text{ }\mu\text{A}.$$

Leakage derating depending on voltage level ( $DV = V_{DDP} - V_{PIN}$  [V]):

$$I_{OZ} = I_{OZtempmax} - (1.6 \times DV) \text{ [}\mu\text{A]}$$

This voltage derating formula is an approximation which applies for maximum temperature.

- 7) Keep current: Limit the current through this pin to the indicated value so that the enabled pull device can keep the default pin level:  $V_{PIN} \geq V_{IH}$  for a pull-up;  $V_{PIN} \leq V_{IL}$  for a pull-down.

Force current: Drive the indicated minimum current through this pin to change the default pin level driven by the enabled pull device:  $V_{PIN} \leq V_{IL}$  for a pull-up;  $V_{PIN} \geq V_{IH}$  for a pull-down.

These values apply to the fixed pull-devices in dedicated pins and to the user-selectable pull-devices in general purpose IO pins.

### 29.5.3 DC Parameters of Port 2

These parameters apply to the IO voltage range,  $4.5 \text{ V} \leq V_{DDP} \leq 5.5 \text{ V}$ .

*Note: Operating Conditions apply.*

*Keeping signal levels within the limits specified in this table ensures operation without overload conditions.*

*For signal levels outside these specifications, also refer to the specification of the overload current  $I_{OV}$ .*

**Table 32 DC Characteristics Port 2**

$V_S = 5.5 \text{ V to } 28 \text{ V}$ ,  $T_J = -40 \text{ }^\circ\text{C to } +150 \text{ }^\circ\text{C}$ , all voltages with respect to ground, positive current flowing into pin (unless otherwise specified)

| Parameter               | Symbol               | Values                |                       |                      | Unit          | Note / Test Condition  | Number   |
|-------------------------|----------------------|-----------------------|-----------------------|----------------------|---------------|--|----------|
|                         |                      | Min.                  | Typ.                  | Max.                 |               |  |          |
| Input low voltage       | $V_{IL}$             | -0.3                  | –                     | $0.3 \times V_{DDP}$ | V             | <sup>1)</sup> $4.5\text{V} \leq V_{DDP} \leq 5.5\text{V}$  | P_5.2.1  |
| Input low voltage       | $V_{IL\_extend}$     | -0.3                  | $0.42 \times V_{DDP}$ | –                    | V             | <sup>2)</sup> $2.6\text{V} \leq V_{DDP} \leq 4.5\text{V}$  | P_5.2.10 |
| Input high voltage      | $V_{IH}$             | $0.7 \times V_{DDP}$  | –                     | $V_{DDP} + 0.3$      | V             | <sup>1)</sup> $4.5\text{V} \leq V_{DDP} \leq 5.5\text{V}$  | P_5.2.2  |
| Input high voltage      | $V_{IH\_extend}$     | –                     | $0.52 \times V_{DDP}$ | $V_{DDP} + 0.3$      | V             | <sup>2)</sup> $2.6\text{V} \leq V_{DDP} \leq 4.5\text{V}$  | P_5.2.11 |
| Input hysteresis        | $HYS_{P2}$           | $0.11 \times V_{DDP}$ | –                     | –                    | V             | <sup>2)</sup> Series resistance = $0 \text{ }\Omega$ ; $4.5\text{V} \leq V_{DDP} \leq 5.5\text{V}$ | P_5.2.3  |
| Input hysteresis        | $HYS_{P2\_ext\_end}$ | –                     | $0.09 \times V_{DDP}$ | –                    | V             | <sup>2)</sup> Series resistance = $0 \text{ }\Omega$ ; $2.6\text{V} \leq V_{DDP} < 4.5\text{V}$    | P_5.2.12 |
| Input leakage current   | $I_{OZ2}$            | -400                  | –                     | +400                 | nA            | $T_J \leq 85^\circ\text{C}$ , $0 \text{ V} < V_{IN} < V_{DDP}$                                     | P_5.2.4  |
| Pull level keep current | $I_{PLK}$            | -30                   | –                     | +30                  | $\mu\text{A}$ | <sup>3)</sup> $V_{PIN} \geq V_{IH}$ (up)<br>$V_{PIN} \leq V_{IL}$ (dn)                             | P_5.2.5  |

**Table 32 DC Characteristics Port 2 (cont'd)**

$V_S = 5.5\text{ V to }28\text{ V}$ ,  $T_j = -40\text{ °C to }+150\text{ °C}$ , all voltages with respect to ground, positive current flowing into pin (unless otherwise specified)

| Parameter                                | Symbol    | Values |      |      | Unit          | Note / Test Condition  | Number  |
|--|-----------|--------|------|------|---------------|--|---------|
|  |           | Min.   | Typ. | Max. |               |  |         |
| Pull level force current                 | $I_{PLF}$ | -750   | –    | +750 | $\mu\text{A}$ | <sup>3)</sup> $V_{PIN} \leq V_{IL}$ (up)<br>$V_{PIN} \geq V_{IH}$ (dn) | P_5.2.6 |
| Pin capacitance (digital inputs/outputs) | $C_{IO}$  | –      | –    | 10   | pF            | <sup>2)</sup>  | P_5.2.7 |

1) Tested at  $V_{DDP} = 5\text{V}$ , specified for  $4.5\text{V} < V_{DDP} < 5.5\text{V}$ .

2) Not subject to production test, specified by design.

3) Keep current: Limit the current through this pin to the indicated value so that the enabled pull device can keep the default pin level:  $V_{PIN} \geq V_{IH}$  for a pull-up;  $V_{PIN} \leq V_{IL}$  for a pull-down.  
Force current: Drive the indicated minimum current through this pin to change the default pin level driven by the enabled pull device:  $V_{PIN} \leq V_{IL}$  for a pull-up;  $V_{PIN} \geq V_{IH}$  for a pull-down.

## 29.6 PWM Interface

### 29.6.1 Electrical Characteristics

**Table 33 Electrical Characteristics PWM Interface**

$V_S = 5.5V$  to  $18V$ ,  $T_j = -40\text{ }^\circ\text{C}$  to  $+150\text{ }^\circ\text{C}$ , all voltages with respect to ground, positive current flowing into pin (unless otherwise specified)

| Parameter  | Symbol               | Values             |                   |                    | Unit          | Note / Test Condition  | Number   |
|--|----------------------|--------------------|-------------------|--------------------|---------------|--|----------|
|  |                      | Min.               | Typ.              | Max.               |               |  |          |
| <b>Bus Receiver Interface</b>                                |                      |                    |                   |                    |               |  |          |
| Receiver threshold voltage, recessive to dominant edge       | $V_{th\_dom}$        | $0.4 \times V_S$   | $0.45 \times V_S$ | $0.53 \times V_S$  | V             | SAE J2602  | P_6.1.1  |
| Receiver dominant state                                      | $V_{BUSdom}$         | -27                | –                 | $0.4 \times V_S$   | V             | –  | P_6.1.2  |
| Receiver threshold voltage, dominant to recessive edge       | $V_{th\_rec}$        | $0.47 \times V_S$  | $0.55 \times V_S$ | $0.6 \times V_S$   | V             | SAE J2602  | P_6.1.3  |
| Receiver recessive state                                     | $V_{BUSrec}$         | $0.6 \times V_S$   | –                 | $1.15 \times V_S$  | V             | <sup>1)</sup>  | P_6.1.4  |
| Receiver center voltage                                      | $V_{BUS\_CN}$<br>$T$ | $0.475 \times V_S$ | $0.5 \times V_S$  | $0.525 \times V_S$ | V             | <sup>2)</sup>  | P_6.1.5  |
| Receiver hysteresis  | $V_{HYS}$            | $0.07 V_S$         | $0.12 \times V_S$ | $0.175 \times V_S$ | V             | <sup>3)</sup>  | P_6.1.6  |
| Wake-up threshold voltage                                    | $V_{BUS,wk}$         | $0.4 \times V_S$   | $0.5 \times V_S$  | $0.6 \times V_S$   | V             | –  | P_6.1.7  |
| Dominant time for bus wake-up (internal analog filter delay) | $t_{WK,bus}$         | 3                  | –                 | 15                 | $\mu\text{s}$ | The overall dominant time for bus wake-up is a sum of $t_{WK,bus}$ + adjustable digital filter time.   | P_6.1.8  |
| <b>Bus Transmitter Interface</b>                             |                      |                    |                   |                    |               |  |          |
| Bus recessive output voltage                                 | $V_{BUS,ro}$         | $0.8 \times V_S$   | –                 | $V_S$              | V             | $V_{TXD} = \text{high Level}$  | P_6.1.9  |
| Bus short circuit current                                    | $I_{BUS,sc}$         | 40                 | 100               | 150                | mA            | Current Limitation for driver dominant state driver on $V_{BUS} = 18\text{ V}$ ;   | P_6.1.10 |
| Bus short circuit filter time                                | $t_{BUS,sc}$         | –                  | 5                 | –                  | $\mu\text{s}$ | <sup>9)</sup> The overall bus short circuit filter time is a sum of $t_{BUS,sc}$ + digital filter time. The digital filter time is $4\text{ }\mu\text{s}$ (typ.) | P_6.1.71 |
| Leakage current (loss of ground)                             | $I_{BUS\_NO\_GND}$   | -1000              | -450              | 1000               | $\mu\text{A}$ | $V_S = 12\text{ V}$ ; $0 < V_{BUS} < 18\text{ V}$ ;  | P_6.1.11 |
| Leakage current  | $I_{BUS\_NO\_BAT}$   | –                  | 10                | 20                 | $\mu\text{A}$ | $V_S = 0\text{ V}$ ; $V_{BUS} = 18\text{ V}$ ;   | P_6.1.12 |

**Electrical Characteristics**
**Table 33 Electrical Characteristics PWM Interface (cont'd)**
 $V_S = 5.5V$  to  $18V$ ,  $T_j = -40\text{ }^\circ\text{C}$  to  $+150\text{ }^\circ\text{C}$ , all voltages with respect to ground, positive current flowing into pin (unless otherwise specified)

| Parameter              | Symbol                     | Values |      |      | Unit          | Note / Test Condition  | Number   |
|------------------------|----------------------------|--------|------|------|---------------|--|----------|
|                        |                            | Min.   | Typ. | Max. |               |  |          |
| Leakage current        | $I_{\text{BUS\_PAS\_dom}}$ | -1     | –    | –    | mA            | $V_S = 18\text{ V}; V_{\text{BUS}} = 0\text{ V};$  | P_6.1.13 |
| Leakage current        | $I_{\text{BUS\_PAS\_rec}}$ | –      | –    | 20   | $\mu\text{A}$ | $V_S = 8\text{ V}; V_{\text{BUS}} = 18\text{ V};$  | P_6.1.14 |
| Bus pull-up resistance | $R_{\text{BUS}}$           | 20     | 30   | 47   | k $\Omega$    | Normal mode  | P_6.1.15 |
| ON-State Resistance    | $R_{\text{ON}}$            | –      | 20   | –    | $\Omega$      | <sup>7)</sup> $V_S > 5.5\text{ V}, I_{\text{ds}} = 150\text{ mA}, T_j = 27\text{ }^\circ\text{C};$ | P_6.1.72 |

**AC Characteristics - Transceiver Normal Slope Mode**

|   |                     |       |   |       |               |   |          |
|---|---------------------|-------|---|-------|---------------|---|----------|
| Propagation delay bus dominant to RxD LOW                     | $t_{\text{d(L),R}}$ | 0.1   | – | 6     | $\mu\text{s}$ | –   | P_6.1.16 |
| Propagation delay bus recessive to RxD HIGH                   | $t_{\text{d(H),R}}$ | 0.1   | – | 6     | $\mu\text{s}$ | –   | P_6.1.17 |
| Receiver delay symmetry                                       | $t_{\text{sym,R}}$  | -2    | – | 2     | $\mu\text{s}$ | $t_{\text{sym,R}} = t_{\text{d(L),R}} - t_{\text{d(H),R}};$   | P_6.1.18 |
| Duty cycle D1 Normal Slope Mode (for worst case at 20 kbit/s) | $t_{\text{duty1}}$  | 0.396 | – | –     |               | <sup>4)</sup> duty cycle 1<br>$\text{TH}_{\text{Rec}}(\text{max}) = 0.744 \times V_S;$<br>$\text{TH}_{\text{Dom}}(\text{max}) = 0.581 \times V_S; V_S = 5.5 \dots 18\text{ V};$<br>$t_{\text{bit}} = 50\text{ } \mu\text{s};$<br>$\text{D1} = t_{\text{bus\_rec}(\text{min})}/2 t_{\text{bit}};$      | P_6.1.19 |
| Duty cycle D2 Normal Slope Mode (for worst case at 20 kbit/s) | $t_{\text{duty2}}$  | –     | – | 0.581 |               | <sup>4)</sup> duty cycle 2<br>$\text{TH}_{\text{Rec}}(\text{min}) = 0.422 \times V_S;$<br>$\text{TH}_{\text{Dom}}(\text{min}) = 0.284 \times V_S;$<br>$V_S = 5.5 \dots 18\text{ V};$<br>$t_{\text{bit}} = 50\text{ } \mu\text{s};$<br>$\text{D2} = t_{\text{bus\_rec}(\text{max})}/2 t_{\text{bit}};$ | P_6.1.20 |

**AC Characteristics - Transceiver Low Slope Mode**

|   |                     |     |   |   |               |   |          |
|---|---------------------|-----|---|---|---------------|---|----------|
| Propagation delay bus dominant to RxD LOW   | $t_{\text{d(L),R}}$ | 0.1 | – | 6 | $\mu\text{s}$ | –   | P_6.1.21 |
| Propagation delay bus recessive to RxD HIGH | $t_{\text{d(H),R}}$ | 0.1 | – | 6 | $\mu\text{s}$ | –   | P_6.1.22 |
| Receiver delay symmetry                     | $t_{\text{sym,R}}$  | -2  | – | 2 | $\mu\text{s}$ | $t_{\text{sym,R}} = t_{\text{d(L),R}} - t_{\text{d(H),R}};$ | P_6.1.23 |

**Table 33 Electrical Characteristics PWM Interface (cont'd)**
 $V_S = 5.5V$  to  $18V$ ,  $T_j = -40\text{ }^\circ\text{C}$  to  $+150\text{ }^\circ\text{C}$ , all voltages with respect to ground, positive current flowing into pin (unless otherwise specified)

| Parameter   | Symbol             | Values |      |       | Unit | Note / Test Condition   | Number   |
|---|--------------------|--------|------|-------|------|---|----------|
|   |                    | Min.   | Typ. | Max.  |      |   |          |
| Duty cycle D3<br>(for worst case at<br>10.4 kbit/s) | $t_{\text{duty1}}$ | 0.417  | –    | –     |      | 4) duty cycle 3<br>$TH_{\text{Rec}}(\text{max}) = 0.778 \times V_S$ ;<br>$TH_{\text{Dom}}(\text{max}) = 0.616 \times V_S$ ; $V_S = 5.5 \dots 18\text{ V}$ ;<br>$t_{\text{bit}} = 96\text{ }\mu\text{s}$ ;<br>$D3 = t_{\text{bus\_rec}(\text{min})}/2 t_{\text{bit}}$    | P_6.1.24 |
| Duty cycle D4<br>(for worst case at<br>10.4 kbit/s) | $t_{\text{duty2}}$ | –      | –    | 0.590 |      | 4) duty cycle 4<br>$TH_{\text{Rec}}(\text{min}) = 0.389 \times V_S$ ;<br>$TH_{\text{Dom}}(\text{min}) = 0.251 \times V_S$ ;<br>$V_S = 5.5 \dots 18\text{ V}$ ;<br>$t_{\text{bit}} = 96\text{ }\mu\text{s}$ ;<br>$D4 = t_{\text{bus\_rec}(\text{max})}/2 t_{\text{bit}}$ | P_6.1.25 |

**AC Characteristics - Transceiver Fast Slope Mode**

|  |                     |      |   |     |               |  |          |
|--|---------------------|------|---|-----|---------------|--|----------|
| Propagation delay<br>bus dominant to RxD LOW   | $t_{\text{d(L),R}}$ | 0.1  | – | 6   | $\mu\text{s}$ | –  | P_6.1.26 |
| Propagation delay<br>bus recessive to RxD HIGH | $t_{\text{d(H),R}}$ | 0.1  | – | 6   | $\mu\text{s}$ | –  | P_6.1.27 |
| Receiver delay symmetry                        | $t_{\text{sym,R}}$  | -1.5 | – | 1.5 | $\mu\text{s}$ | $t_{\text{sym,R}} = t_{\text{d(L),R}} - t_{\text{d(H),R}}$ | P_6.1.28 |

**AC Characteristics - Flash Mode**

|  |                      |       |    |       |               |  |          |
|--|----------------------|-------|----|-------|---------------|--|----------|
| Propagation delay<br>bus dominant to RxD LOW   | $t_{\text{d(L),R}}$  | 0.1   | –  | 6     | $\mu\text{s}$ | –  | P_6.1.31 |
| Propagation delay<br>bus recessive to RxD HIGH   | $t_{\text{d(H),R}}$  | 0.1   | –  | 6     | $\mu\text{s}$ | –  | P_6.1.32 |
| Receiver delay symmetry  | $t_{\text{sym,R}}$   | -1.0  | –  | 1.5   | $\mu\text{s}$ | $t_{\text{sym,R}} = t_{\text{d(L),R}} - t_{\text{d(H),R}}$   | P_6.1.33 |
| Duty cycle D7 (for worst<br>case at 115 kbit/s)<br>for +1 $\mu\text{s}$ Receiver delay<br>symmetry | $t_{\text{duty1}}$   | 0.399 | –  | –     |               | 5) duty cycle D7<br>$TH_{\text{Rec}}(\text{max}) = 0.744 \times V_S$ ;<br>$TH_{\text{Dom}}(\text{max}) = 0.581 \times V_S$ ; $V_S = 13.5\text{ V}$ ;<br>$t_{\text{bit}} = 8.7\text{ }\mu\text{s}$ ;<br>$D7 = t_{\text{bus\_rec}(\text{min})}/2 t_{\text{bit}}$ | P_6.1.34 |
| Duty cycle D8 (for worst<br>case at 115 kbit/s)<br>for +1 $\mu\text{s}$ Receiver delay<br>symmetry | $t_{\text{duty2}}$   | –     | –  | 0.578 |               | 6) duty cycle 8<br>$TH_{\text{Rec}}(\text{min}) = 0.422 \times V_S$ ;<br>$TH_{\text{Dom}}(\text{min}) = 0.284 \times V_S$ ; $V_S = 13.5\text{ V}$ ;<br>$t_{\text{bit}} = 8.7\text{ }\mu\text{s}$ ;<br>$D8 = t_{\text{bus\_rec}(\text{max})}/2 t_{\text{bit}}$  | P_6.1.35 |
| PWM interface input<br>capacity  | $C_{\text{PWM\_IN}}$ | –     | 15 | 30    | pF            | 6)   | P_6.1.69 |



**Table 33 Electrical Characteristics PWM Interface (cont'd)**

$V_s = 5.5V$  to  $18V$ ,  $T_j = -40\text{ }^\circ\text{C}$  to  $+150\text{ }^\circ\text{C}$ , all voltages with respect to ground, positive current flowing into pin (unless otherwise specified)

| Parameter             | Symbol               | Values |      |      | Unit | Note / Test Condition         | Number   |
|-----------------------|----------------------|--------|------|------|------|-------------------------------|----------|
|                       |                      | Min.   | Typ. | Max. |      |                               |          |
| TxD dominant time out | $t_{\text{timeout}}$ | 6      | 12   | 20   | ms   | $V_{\text{TxD}} = 0\text{ V}$ | P_6.1.36 |

**Thermal Shutdown (Junction Temperature)**

|                        |                  |     |     |     |                  |               |          |
|------------------------|------------------|-----|-----|-----|------------------|---------------|----------|
| Thermal shutdown temp. | $T_{\text{jSD}}$ | 190 | 200 | 215 | $^\circ\text{C}$ | <sup>7)</sup> | P_6.1.65 |
| Thermal shutdown hyst. | $\Delta T$       | –   | 10  | –   | K                | <sup>7)</sup> | P_6.1.66 |

1) Maximum limit specified by design.

2)  $V_{\text{BUS\_CNT}} = (V_{\text{th\_dom}} + V_{\text{th\_rec}})/2$

3)  $V_{\text{HYS}} = V_{\text{BUSrec}} - V_{\text{BUSdom}}$

4) Bus load :

Load 1 =  $1\text{ nF} / 1\text{ k}\Omega = C_{\text{BUS}} / R_{\text{BUS}}$

Load 2 =  $6.8\text{ nF} / 660\ \Omega = C_{\text{BUS}} / R_{\text{BUS}}$

Load 3 =  $10\text{ nF} / 500\ \Omega = C_{\text{BUS}} / R_{\text{BUS}}$

5) Bus load

Load 1 =  $1\text{ nF} / 500\ \Omega = C_{\text{BUS}} / R_{\text{BUS}}$

6) Not subject to production test, specified by design.

## 29.7 High-Speed Synchronous Serial Interface

### 29.7.1 SSC Timing Parameters

The table below provides the SSC timing in the TLE9861QXA20.

**Table 34 SSC Master Mode Timing (Operating Conditions apply; CL = 50 pF)**

$V_S = 5.5\text{ V to }28\text{ V}$ ,  $T_j = -40\text{ °C to }+150\text{ °C}$ , all voltages with respect to ground, positive current flowing into pin (unless otherwise specified)

| Parameter            | Symbol | Values                          |      |      | Unit | Note / Test Condition                  | Number  |
|----------------------|--------|---------------------------------|------|------|------|--|---------|
|                      |        | Min.                            | Typ. | Max. |      |  |         |
| SCLK clock period    | $t_0$  | <sup>1)</sup> $2 \cdot T_{SSC}$ | –    | –    |      | <sup>2)</sup> $V_{DDP} > 2.7\text{ V}$ | P_7.1.1 |
| MTSR delay from SCLK | $t_1$  | 10                              | –    | –    | ns   | <sup>2)</sup> $V_{DDP} > 2.7\text{ V}$ | P_7.1.2 |
| MRST setup to SCLK   | $t_2$  | 10                              | –    | –    | ns   | <sup>2)</sup> $V_{DDP} > 2.7\text{ V}$ | P_7.1.3 |
| MRST hold from SCLK  | $t_3$  | 15                              | –    | –    | ns   | <sup>2)</sup> $V_{DDP} > 2.7\text{ V}$ | P_7.1.4 |

- 1)  $T_{SSCmin} = T_{CPU} = 1/f_{CPU}$ . If  $f_{CPU} = 20\text{ MHz}$ ,  $t_0 = 100\text{ ns}$ .  $T_{CPU}$  is the CPU clock period.
- 2) Not subject to production test, specified by design.

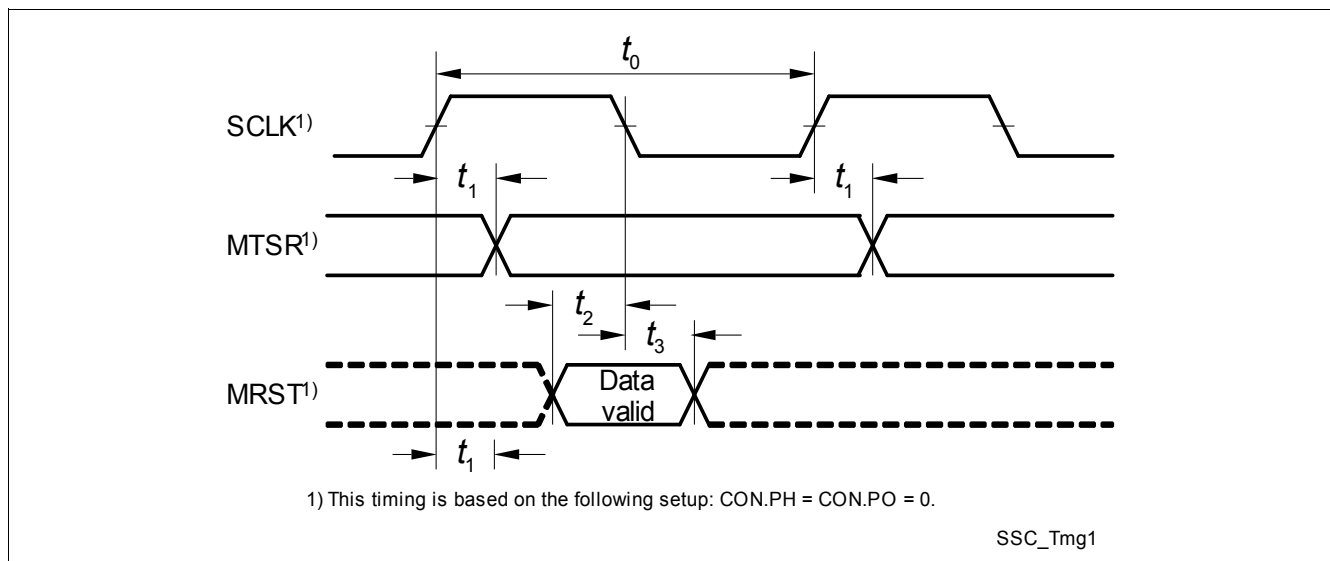

**Figure 36 SSC Master Mode Timing**

## 29.8 Measurement Unit

### 29.8.1 System Voltage Measurement Parameters

**Table 35 Supply Voltage Signal Conditioning**

$V_S = 5.5 \text{ V to } 28 \text{ V}$ ,  $T_j = -40 \text{ }^\circ\text{C to } +150 \text{ }^\circ\text{C}$ , all voltages with respect to ground, positive current flowing into pin (unless otherwise specified)

| Parameter   | Symbol                                       | Values |       |      | Unit | Note / Test Condition   | Number   |
|---|--|--------|-------|------|------|---|----------|
|   |  | Min.   | Typ.  | Max. |      |   |          |
| Measurement output voltage range @ VAREF5                                     | $V_{A5}$                                     | 0      | –     | 5    | V    | –   | P_8.1.15 |
| Measurement output voltage range @ VAREF1V2                                   | $V_{A1V2}$                                   | 0      | –     | 1.23 | V    | –   | P_8.1.16 |
| <b>Battery / Supply Voltage Measurement <math>V_{BAT\_SENSE} / V_S</math></b> |  |        |       |      |      |   |          |
| Input to output voltage attenuation:<br>$V_S$                                 | $ATT_{VS\_1}$                                | –      | 0.055 | –    |      | SFR setting 1   | P_8.1.41 |
| Input to output voltage attenuation:<br>$V_{BAT\_SENSE}$                      | $ATT_{VBAT\_SENSE\_1}$                       | –      | 0.055 | –    |      | SFR setting 1   | P_8.1.60 |
| Nominal operating input voltage range $V_{BAT\_SENSE}$ and $V_S$              | $V_{BAT\_SENSE,range1}, V_{S,range1}$        | 3      | –     | 22   | V    | <sup>1)</sup> SFR setting 1; Max. value corresponds to typ. ADC full scale input; $3\text{V} < V_{BAT\_SENSE} / V_S < 28\text{V}$ | P_8.1.1  |
| Accuracy of $V_{BAT\_SENSE} / V_S$ after calibration                          | $\Delta V_{BAT\_SENSE,range1}, V_{S,range1}$ | -220   | –     | 220  | mV   | SFR setting 1, $V_S = 5.5 \text{ V to } 18\text{V}$   | P_8.1.70 |
| Input to output voltage attenuation:<br>$V_S$                                 | $ATT_{VS\_2}$                                | –      | 0.039 | –    |      | SFR setting 2   | P_8.1.42 |
| Input to output voltage attenuation:<br>$V_{BAT\_SENSE}$                      | $ATT_{VBAT\_SENSE\_2}$                       | –      | 0.039 | –    |      | SFR setting 2   | P_8.1.61 |
| Nominal operating input voltage range $V_{BAT\_SENSE}$ and $V_S$              | $V_{BAT\_SENSE,range2}, V_{S,range2}$        | 3      | –     | 31   | V    | <sup>1)</sup> SFR setting 2; Max. value corresponds to typ. ADC full scale input $3\text{V} < V_{BAT\_SENSE} / V_S < 28\text{V}$  | P_8.1.40 |
| Accuracy of $V_{BAT\_SENSE} / V_S$ after calibration                          | $\Delta V_{BAT\_SENSE,range2}, V_{S,range2}$ | -370   | –     | 370  | mV   | SFR setting 2, $V_S = 5.5\text{V to } 18\text{V}$   | P_8.1.44 |

**Table 35 Supply Voltage Signal Conditioning (cont'd)**
 $V_S = 5.5\text{ V to }28\text{ V}$ ,  $T_j = -40\text{ }^\circ\text{C to }+150\text{ }^\circ\text{C}$ , all voltages with respect to ground, positive current flowing into pin (unless otherwise specified)

| Parameter   | Symbol                           | Values |       |      | Unit          | Note / Test Condition                               | Number   |
|---|----------------------------------|--------|-------|------|---------------|---|----------|
|   |                                  | Min.   | Typ.  | Max. |               |   |          |
| Measurement input leakage current for $V_{BAT\_SENSE}$                | $I_{leak\_VBAT\_SENSE, measure}$ | 0      | –     | 4.0  | $\mu\text{A}$ | PD_N=0 (off-state), $V_{BAT\_SENSE} = 13.5\text{V}$ | P_8.1.72 |
| <b>Driver Supply Voltage Measurement <math>V_{SD}</math></b>          |                                  |        |       |      |               |   |          |
| Input to output voltage attenuation: $V_{SD}$                         | $ATT_{VSD}$                      | –      | 0.039 | –    |               | –   | P_8.1.21 |
| Nominal operating input voltage range $V_{SD}$                        | $V_{SD,range}$                   | 2.5    | –     | 31   | V             | <sup>1)</sup>                                       | P_8.1.2  |
| Accuracy of $V_{SD}$ sense after calibration                          | $\Delta V_{SD}$                  | -440   | –     | 440  | mV            | $V_S = 5.5\text{V to }18\text{V}$                   | P_8.1.47 |
| <b>Charge Pump Voltage Measurement <math>V_{CP}</math></b>            |                                  |        |       |      |               |   |          |
| Input to output voltage attenuation: $V_{CP}$                         | $ATT_{VCP}$                      | –      | 0.023 | –    |               | –   | P_8.1.56 |
| Nominal operating input voltage range $V_{CP}$                        | $V_{CP,range}$                   | 2.5    | –     | 52   | V             | <sup>1)</sup>                                       | P_8.1.7  |
| Accuracy of $V_{CP}$ sense after calibration                          | $\Delta V_{CP}$                  | -747   | –     | 747  | mV            | $V_S = 5.5\text{V to }18\text{V}$                   | P_8.1.62 |
| <b>Monitoring Input Voltage Measurement <math>V_{MON}</math></b>      |                                  |        |       |      |               |   |          |
| Input to output voltage attenuation: $V_{MON}$                        | $ATT_{VMON}$                     | –      | 0.039 | –    |               | –   | P_8.1.49 |
| Nominal operating input voltage range $V_{MON}$                       | $V_{MON,range}$                  | 2.5    | –     | 31   | V             | <sup>1)</sup>                                       | P_8.1.8  |
| Accuracy of $V_{MON}$ sense after calibration                         | $\Delta V_{MON}$                 | -440   | –     | 440  | mV            | $V_S = 5.5\text{V to }18\text{V}$                   | P_8.1.68 |
| <b>Pad Supply Voltage Measurement <math>V_{VDDP}</math></b>           |                                  |        |       |      |               |   |          |
| Input-to-output voltage attenuation: $V_{DDP}$                        | $ATT_{VDDP}$                     | –      | 0.164 | –    |               | –   | P_8.1.33 |
| Nominal operating input voltage range $V_{DDP}$                       | $V_{DDP,range}$                  | 0      | –     | 7.50 | V             | <sup>1)</sup>                                       | P_8.1.50 |
| Accuracy of $V_{DDP}$ sense after calibration                         | $\Delta V_{DDP\_SENSE}$          | -105   | –     | 105  | mV            | <sup>2)</sup> $V_S = 5.5\text{ to }18\text{V}$      | P_8.1.5  |
| <b>10-Bit ADC Reference Voltage Measurement <math>V_{AREF}</math></b> |                                  |        |       |      |               |   |          |
| Input to output voltage attenuation: $V_{AREF}$                       | $ATT_{VAREF}$                    | –      | 0.219 | –    |               | –   | P_8.1.22 |

**Table 35 Supply Voltage Signal Conditioning (cont'd)**
 $V_S = 5.5 \text{ V to } 28 \text{ V}$ ,  $T_j = -40 \text{ }^\circ\text{C to } +150 \text{ }^\circ\text{C}$ , all voltages with respect to ground, positive current flowing into pin (unless otherwise specified)

| Parameter  | Symbol                  | Values |       |      | Unit | Note / Test Condition  | Number   |
|--|-------------------------|--------|-------|------|------|--|----------|
|  |                         | Min.   | Typ.  | Max. |      |  |          |
| Nominal operating input voltage range $V_{AREF}$                   | $V_{AREF,range}$        | 0      | –     | 5.62 | V    | <sup>1)</sup>  | P_8.1.51 |
| Accuracy of $V_{AREF}$ sense after calibration                     | $\Delta V_{AREF}$       | -79    | –     | 79   | mV   | $V_S = 5.5\text{V to } 18\text{V}$   | P_8.1.48 |
| <b>8-Bit ADC Reference Voltage Measurement <math>V_{BG}</math></b> |                         |        |       |      |      |  |          |
| Input-to-output voltage attenuation: $V_{BG}$                      | $ATT_{V_{BG}}$          | –      | 0.75  | –    |      | –  | P_8.1.57 |
| Nominal operating input voltage range $V_{BG}$                     | $V_{BG,range}$          | 0.8    | –     | 1.64 | V    | <sup>1)</sup>  | P_8.1.52 |
| Value of ADC2- $V_{BG}$ measurement after calibration              | $V_{BG\_PMU}$           | 1.01   | 1.07  | 1.18 | V    |  | P_8.1.73 |
| <b>Core supply Voltage Measurement <math>V_{DDC}</math></b>        |                         |        |       |      |      |  |          |
| Input-to-output voltage attenuation: $V_{DDC}$                     | $ATT_{V_{DDC}}$         | –      | 0.75  | –    |      | –  | P_8.1.34 |
| Nominal operating input voltage range $V_{DDC}$                    | $V_{DDC,range}$         | 0.8    | –     | 1.64 | V    | <sup>1)</sup>  | P_8.1.53 |
| Accuracy of $V_{DDC}$ sense after calibration                      | $\Delta V_{DDC\_SENSE}$ | -22    | –     | 22   | mV   | $V_S = 5.5 \text{ to } 18\text{V}$   | P_8.1.6  |
| <b>VDH Input Voltage Measurement <math>V_{VDH10BITADC}</math></b>  |                         |        |       |      |      |  |          |
| VDH Input to output voltage attenuation:                           | $ATT_{VDH\_1}$          | –      | 0.166 | –    |      | SFR setting 1  | P_8.1.64 |
| VDH Input to output voltage attenuation:                           | $ATT_{VDH\_2}$          | –      | 0.224 | –    |      | SFR setting 2  | P_8.1.65 |
| VDH Input to output voltage attenuation:                           | $ATT_{VDH\_3}$          | –      | 0.226 | –    |      | <sup>1)</sup> SFR setting 2<br>$T_j = -40..85^\circ\text{C}$   | P_8.1.75 |
| Nominal operating input voltage range $V_{VDH}$ , Range 1          | $V_{VDH,range1}$        | –      | –     | 30   |      | SFR setting 1  | P_8.1.66 |
| Nominal operating input voltage range $V_{VDH}$ , Range 2          | $V_{VDH,range2}$        | –      | –     | 20   |      | SFR setting 2  | P_8.1.67 |
| $V_{VDH}$ 10-bit ADC, Range 1                                      | $\Delta V_{VDHADC10B}$  | -300   | –     | 300  | mV   | $V_{DH} = 5.5 \text{ to } 17.5\text{V}$ ,<br>$T_j = -40..150^\circ\text{C}$                                | P_8.1.39 |
| $V_{VDH}$ 10-bit ADC, Range 3                                      | $\Delta V_{VDHADC10B}$  | -200   | –     | 200  | mV   | <sup>1)</sup> $V_{DH} = 5.5 \text{ to } 17.5\text{V}$ ,<br>$T_j = -40..85^\circ\text{C}$<br>$ATT_{VDH\_3}$ | P_8.1.71 |

**Table 35 Supply Voltage Signal Conditioning (cont'd)**

$V_S = 5.5\text{ V to }28\text{ V}$ ,  $T_j = -40\text{ °C to }+150\text{ °C}$ , all voltages with respect to ground, positive current flowing into pin (unless otherwise specified)

| Parameter                                       | Symbol                            | Values |      |      | Unit | Note / Test Condition   | Number   |
|---|-----------------------------------|--------|------|------|------|---|----------|
|   |                                   | Min.   | Typ. | Max. |      |   |          |
| $V_{VDH}$ 10-bit ADC, Range 2                   | $\Delta V_{VDHADC10B\_extend\_T}$ | -400   | –    | 400  | mV   | $V_{DH} = 5.5\text{V to }17.5\text{V}$ ,<br>$T_j = -40..150\text{°C}$ | P_8.1.74 |
| 10-Bit ADC measurement input resistance for VDH | $R_{in\_VDH,measure}$             | 200    | 390  | 470  | kΩ   | PD_N=1 (on-state)   | P_8.1.3  |
| Measurement input leakage current for $V_{VDH}$ | $I_{leak\_VDH,measure}$           | -0.05  | –    | 2.0  | μA   | PD_N=0 (off-state),<br>$V_{VDH} = 13.5\text{V}$                       | P_8.1.10 |

1) Not subject to production test, specified by design.

2) Accuracy is valid for a calibrated device.

**29.8.2 Central Temperature Sensor Parameters**
**Table 36 Electrical Characteristics Temperature Sensor Module**

$V_S = 3.0\text{ V to }28\text{ V}$ ,  $T_j = -40\text{ °C to }+150\text{ °C}$ ; all voltages with respect to ground, positive current flowing into pin (unless otherwise specified)

| Parameter   | Symbol | Values |       |      | Unit | Note / Test Condition                                 | Number  |
|---|--------|--------|-------|------|------|---|---------|
|   |        | Min.   | Typ.  | Max. |      |   |         |
| Output voltage $V_{TEMP}$ at $T_0=273\text{ K (0°C)}$ | a      | –      | 0.666 | –    | V    | <sup>1)</sup><br>$T_0=273\text{ K (0°C)}$             | P_8.2.2 |
| Temperature sensitivity b                             | b      | –      | 2.31  | –    | mV/K | <sup>1)</sup>   | P_8.2.4 |
| Accuracy_1  | Acc_1  | -10    | –     | 10   | °C   | <sup>2)1)</sup> $-40\text{ °C} < T_j < 85\text{ °C}$  | P_8.2.5 |
| Accuracy_2  | Acc_2  | -10    | –     | 10   | °C   | <sup>2)1)</sup> $125\text{ °C} < T_j < 150\text{ °C}$ | P_8.2.6 |
| Accuracy_3  | Acc_3  | -5     | –     | 5    | °C   | <sup>2)1)</sup> $85\text{ °C} < T_j < 125\text{ °C}$  | P_8.2.7 |

1) Not subject to production test, specified by design

2) Accuracy with reference to on-chip temperature calibration measurement, valid for Mode1

### 29.8.3 ADC2-VBG

#### 29.8.3.1 ADC2 Reference Voltage VBG

**Table 37 DC Specifications**

$V_S = 3.0\text{ V to }28\text{ V}$ ,  $T_j = -40\text{ °C to }+150\text{ °C}$ ; all voltages with respect to ground, positive current flowing into pin (unless otherwise specified)

| Parameter         | Symbol   | Values |       |       | Unit | Note / Test Condition | Number  |
|-------------------|----------|--------|-------|-------|------|-----------------------|---------|
|                   |          | Min.   | Typ.  | Max.  |      |                       |         |
| Reference Voltage | $V_{BG}$ | 1.199  | 1.211 | 1.223 | V    | 1)                    | P_8.3.1 |

1) Not subject to production test, spedesign

#### 29.8.3.2 ADC2 Specifications

**Table 38 DC Specifications**

$V_S = 5.5\text{ V to }28\text{ V}$ ,  $T_j = -40\text{ °C to }+150\text{ °C}$ ; all voltages with respect to ground, positive current flowing into pin (unless otherwise specified)

| Parameter                        | Symbol                | Values |      |      | Unit | Note / Test Condition | Number   |
|----------------------------------|-----------------------|--------|------|------|------|-----------------------|----------|
|                                  |                       | Min.   | Typ. | Max. |      |                       |          |
| Resolution                       | $RES$                 | –      | 8    | –    | Bits | Full                  | P_8.3.18 |
| Guaranteed offset error          | $EA_{OFF\_8}$<br>Bit  | -2.0   | ±0.3 | 2.0  | LSB  | not calibrated        | P_8.3.19 |
| Gain error                       | $EA_{Gain\_8}$<br>Bit | -2.0   | ±0.5 | 2.0  | %FSR | not calibrated        | P_8.3.20 |
| Differential non-linearity (DNL) | $EA_{DNL\_8}$<br>Bit  | -0.8   | ±0   | 0.8  | LSB  | Full                  | P_8.3.21 |
| Integral non-linearity (INL)     | $EA_{INL\_8Bit}$      | -1.2   | ±0   | 1.2  | LSB  | –                     | P_8.3.22 |



**29.9 ADC1 Reference Voltage - VAREF**
**29.9.1 Electrical Characteristics VAREF**
**Table 39 Electrical Characteristics VAREF**

$V_S = 5.5\text{ V to }28\text{ V}$ ,  $T_j = -40\text{ °C to }+150\text{ °C}$ , all voltages with respect to ground, positive current flowing into pin (unless otherwise specified)

| Parameter                       | Symbol          | Values |      |      | Unit | Note / Test Condition  | Number   |
|---------------------------------|-----------------|--------|------|------|------|--|----------|
|                                 |                 | Min.   | Typ. | Max. |      |  |          |
| Required buffer capacitance     | $C_{VAREF}$     | 0.1    | –    | 1    | μF   | ESR < 1Ω   | P_9.1.1  |
| Reference output voltage        | $V_{AREF}$      | 4.95   | 5    | 5.05 | V    | $V_S > 5.5\text{V}$  | P_9.1.2  |
| DC supply voltage rejection     | $DC_{PSRVAREF}$ | 30     | –    | –    | dB   | <sup>1)</sup> –  | P_9.1.3  |
| Supply voltage ripple rejection | $AC_{PSRVAREF}$ | 26     | –    | –    | dB   | <sup>1)</sup> $V_S = 13.5\text{V}; f = 0 \dots 1\text{KHz}; V_r = 2\text{Vpp}$ | P_9.1.4  |
| Turn ON time                    | $t_{so}$        | –      | –    | 200  | μs   | <sup>1)</sup> $C_{ext} = 100\text{nF}$<br>PD_N to 99.9% of final value         | P_9.1.5  |
| Input resistance at VAREF Pin   | $R_{IN,VAREF}$  | –      | 100  | –    | kΩ   | <sup>1)</sup> input impedance in case of VAREF is applied from external        | P_9.1.20 |

1) Not subject to production test, specified by design.

**29.9.2 Electrical Characteristics ADC1 (10-Bit)**

These parameters describe the conditions for optimum ADC performance.

*Note: Operating Conditions apply.*

**Table 40 A/D Converter Characteristics**

$V_S = 5.5\text{ V to }28\text{ V}$ ,  $T_j = -40\text{ °C to }+150\text{ °C}$ ; all voltages with respect to ground, positive current flowing into pin (unless otherwise specified)

| Parameter                                    | Symbol                    | Values  |   |   | Unit   | Note / Test Condition                | Number   |
|--|---------------------------|---|---|---|--------|--------------------------------------|----------|
|  |                           | Min.  | Typ.  | Max.  |        |                                      |          |
| Analog reference supply                      | $V_{AREF}$                | $V_{AGND} + 1.0$                                | –   | $V_{DDPA} + 0.05$                               | V      | 1)                                   | P_9.2.1  |
| Analog reference ground                      | $V_{AGND}$                | $V_{SS} - 0.05$                                 | –   | 1.5   | V      | –                                    | P_9.2.2  |
| Analog input voltage range                   | $V_{AIN}$                 | $V_{AGND}$                                      | –   | $V_{AREF}$                                      | V      | 2)                                   | P_9.2.3  |
| Analog clock frequency                       | $f_{ADCI}$                | 5   | –   | 24  | MHz    | 3)                                   | P_9.2.4  |
| Conversion time for 10-bit result            | $t_{C10}$                 | $(13 + STC) \times t_{ADCI} + 2 \times t_{SYS}$ | $(13 + STC) \times t_{ADCI} + 2 \times t_{SYS}$ | $(13 + STC) \times t_{ADCI} + 2 \times t_{SYS}$ | –      | 1)4)                                 | P_9.2.5  |
| Conversion time for 8-bit result             | $t_{C8}$                  | $(11 + STC) \times t_{ADCI} + 2 \times t_{SYS}$ | $(11 + STC) \times t_{ADCI} + 2 \times t_{SYS}$ | $(11 + STC) \times t_{ADCI} + 2 \times t_{SYS}$ | –      | 1)                                   | P_9.2.6  |
| Wakeup time from analog powerdown, fast mode | $t_{WAF}$                 | –   | –   | 4   | µs     | 1)                                   | P_9.2.7  |
| Wakeup time from analog powerdown, slow mode | $t_{WAS}$                 | –   | –   | 15  | µs     | 1)5)                                 | P_9.2.8  |
| Total unadjusted error (8 bit)               | $TUE_{8B}$                | -2  | ±1  | +2  | counts | 6)7)Reference is internal $V_{AREF}$ | P_9.2.9  |
| Total unadjusted error (10 bit)              | $TUE_{10B}$               | -12   | ±6  | +12   | counts | 7)8)Reference is internal $V_{AREF}$ | P_9.2.22 |
| DNL error                                    | $EA_{DNL}$                | -3  | ±0.8  | +3  | counts | –                                    | P_9.2.10 |
| INL error                                    | $EA_{INL\_int\_V\_AREF}$  | -5  | ±0.8  | +5  | counts | Reference is internal $V_{AREF}$     | P_9.2.11 |
| Gain error                                   | $EA_{GAIN\_int\_V\_AREF}$ | -10   | ±0.4  | +10   | counts | Reference is internal $V_{AREF}$     | P_9.2.12 |
| Offset error                                 | $EA_{OFF}$                | -2  | ±0.5  | +2  | counts | –                                    | P_9.2.13 |
| Total capacitance of an analog input         | $C_{AINT}$                | –   | –   | 10  | pF     | 1)5)9)                               | P_9.2.14 |
| Switched capacitance of an analog input      | $C_{AINS}$                | –   | –   | 4   | pF     | 1)5)9)                               | P_9.2.15 |
| Resistance of the analog input path          | $R_{AIN}$                 | –   | –   | 2   | kΩ     | 1)5)9)                               | P_9.2.16 |

**Table 40 A/D Converter Characteristics (cont'd)**
 $V_S = 5.5\text{ V to }28\text{ V}$ ,  $T_j = -40\text{ °C to }+150\text{ °C}$ ; all voltages with respect to ground, positive current flowing into pin (unless otherwise specified)

| Parameter                                   | Symbol      | Values |      |      | Unit       | Note / Test Condition | Number   |
|---|-------------|--------|------|------|------------|-----------------------|----------|
|   |             | Min.   | Typ. | Max. |            |                       |          |
| Total capacitance of the reference input    | $C_{AREFT}$ | –      | –    | 15   | pF         | 1)5)9)                | P_9.2.17 |
| Switched capacitance of the reference input | $C_{AREFS}$ | –      | –    | 7    | pF         | 1)5)9)                | P_9.2.18 |
| Resistance of the reference input path      | $R_{AREF}$  | –      | –    | 2    | k $\Omega$ | 1)5)9)                | P_9.2.19 |

- 1) Not subject to production test, specified by design.
- 2)  $V_{AIN}$  may exceed  $V_{AGND}$  or  $V_{AREFX}$  up to the absolute maximum ratings. However, the conversion result in these cases will be 0000<sub>H</sub> or 03FF<sub>H</sub>, respectively.
- 3) The limit values for  $f_{ADCI}$  must not be exceeded when selecting the peripheral frequency and the prescaler setting.
- 4) This parameter includes the sample time (also the additional sample time specified by STC), the time to determine the digital result and the time to load the result register with the conversion result.
- 5) The broken wire detection delay against  $V_{AGND}$  is measured in numbers of consecutive precharge cycles at a conversion rate of not more than 500  $\mu\text{s}$ .
- 6) The total unadjusted error TUE is the maximum deviation from the ideal ADC transfer curve, not the sum of individual errors.  
All error specifications are based on measurement methods standardized by IEEE 1241.2000.
- 7) The specified TUE is valid only if the absolute sum of input overload currents (see  $I_{OV}$  specification) does not exceed 10 mA, and if  $V_{AREF}$  and  $V_{AGND}$  remain stable during the measurement time.
- 8) The total unadjusted error TUE is the maximum deviation from the ideal ADC transfer curve, not the sum of individual errors.  
All error specifications are based on measurement methods standardized by IEEE 1241.2000.
- 9) These parameter values cover the complete operating range. Under relaxed operating conditions (temperature, supply voltage) typical values can be used for calculation. At room temperature and nominal supply voltage the following typical values can be used:  
 $C_{AINTyp} = 12\text{ pF}$ ,  $C_{AINStyp} = 5\text{ pF}$ ,  $R_{AINTyp} = 1.0\text{ k}\Omega$ ,  $C_{AREFTyp} = 15\text{ pF}$ ,  $C_{AREFSStyp} = 10\text{ pF}$ ,  $R_{AREFTyp} = 1.0\text{ k}\Omega$ .

## 29.10 Reserved

## 29.11 High-Voltage Monitoring Input

### 29.11.1 Electrical Characteristics

**Table 41 Electrical Characteristics Monitoring Input**

$T_j = -40\text{ °C to }+150\text{ °C}$ ;  $V_S = 5.5\text{ V to }28\text{ V}$ , all voltages with respect to ground, positive current flowing into pin (unless otherwise specified)

| Parameter   | Symbol                | Values            |                  |                  | Unit          | Note / Test Condition  | Number    |
|---|-----------------------|-------------------|------------------|------------------|---------------|--|-----------|
|   |                       | Min.              | Typ.             | Max.             |               |  |           |
| <b>MON Input Pin characteristics</b>                |                       |                   |                  |                  |               |  |           |
| Wake-up/monitoring threshold voltage                | $V_{MONth}$           | $0.4 \cdot V_S$   | $0.5 \cdot V_S$  | $0.6 \cdot V_S$  | V             | Without external serial resistor $R_s$ (with $R_s:DV = I_{PD/PU} \cdot R_s$ ); $V_S = 5.5\text{V to }18\text{V}$   | P_11.1.1  |
| Wake-up/monitoring threshold voltage extended range | $V_{MONth\_ext\ end}$ | $0.44 \cdot V_S$  | $0.53 \cdot V_S$ | $0.64 \cdot V_S$ | V             | Without external serial resistor $R_s$ (with $R_s:DV = I_{PD/PU} \cdot R_s$ )  | P_11.1.11 |
| Threshold hysteresis                                | $V_{MONth,hys}$       | $0.015 \cdot V_S$ | $0.05 \cdot V_S$ | $0.1 \cdot V_S$  | V             | In all modes; without external serial resistor $R_s$ (with $R_s:dV = I_{PD/PU} \cdot R_s$ ); $V_S = 5.5\text{V to }18\text{V}$ ;   | P_11.1.12 |
| Threshold hysteresis                                | $V_{MONth,hys}$       | $0.02 \cdot V_S$  | $0.06 \cdot V_S$ | $0.12 \cdot V_S$ | V             | In all modes; without external serial resistor $R_s$ (with $R_s:dV = I_{PD/PU} \cdot R_s$ ); $V_S = 18\text{V to }28\text{V}$ ;  | P_11.1.2  |
| Pull-up current                                     | $I_{PU, MON}$         | -20               | -10              | -1               | $\mu\text{A}$ | $0.6 \cdot V_S$  | P_11.1.3  |
| Pull-down current                                   | $I_{PD, MON}$         | 3                 | 10               | 20               | $\mu\text{A}$ | $0.4 \cdot V_S$  | P_11.1.4  |
| Input leakage current                               | $I_{LK, MON}$         | -2.5              | –                | 2.5              | $\mu\text{A}$ | <sup>1)</sup> $0\text{ V} < V_{MON\_IN} < 28\text{ V}$   | P_11.1.5  |
| <b>Timing</b>                                       |                       |                   |                  |                  |               |  |           |
| Wake-up filter time (internal analog filter delay)  | $t_{FT, MON}$         | –                 | 500              | –                | ns            | <sup>2)</sup> The overall filter time for MON wake-up is a sum of $t_{FT, MON}$ + adjustable digital filter time. The digital filter time can be adjusted by PMU.CNF_WAKE_FILTER.CNF_MON_FT; | P_11.1.6  |

1) Input leakage is valid for disabled state.

2) With pull-up, pull down current disabled.

## 29.12 MOSFET Driver

### 29.12.1 Electrical Characteristics

**Table 42 Electrical Characteristics MOSFET Driver**

$V_S = 5.5 \text{ V to } 28 \text{ V}$ ,  $T_j = -40 \text{ }^\circ\text{C to } +150 \text{ }^\circ\text{C}$ , all voltages with respect to ground, positive current flowing into pin (unless otherwise specified)

| Parameter  | Symbol                   | Values |      |      | Unit | Note / Test Condition   | Number    |
|--|--------------------------|--------|------|------|------|---|-----------|
|  |                          | Min.   | Typ. | Max. |      |   |           |
| <b>MOSFET Driver Output</b>                        |                          |        |      |      |      |   |           |
| Maximum total charge driver capability             | $Q_{\text{tot\_max}}$    | –      | –    | 100  | nC   | <sup>1)</sup> Due to Charge Pump current capability only 3 x MOSFETs + additional external capacitors with a total charge of max. 100nC can be driven simultaneous at a PWM frequency of 25 kHz.                                  | P_12.1.20 |
| Source current - Charge current - High Side Driver | $I_{\text{Soumax\_HS}}$  | 230    | 345  | 450  | mA   | $V_{SD} \geq 8 \text{ V}$ , $C_{\text{Load}} = 10 \text{ nF}$ ,<br>$I_{\text{Sou}} = C_{\text{Load}} * \text{slew rate} (= 20\%-50\% \text{ of } V_{\text{GHx1}})$ ,<br>$I_{\text{CHARGE}} = I_{\text{DISCHG}} = 31(\text{max})$  | P_12.1.78 |
| Sink current - Discharge current-High Side Driver  | $I_{\text{Sinkmax\_HS}}$ | 230    | 330  | 450  | mA   | $V_{SD} \geq 8 \text{ V}$ , $C_{\text{Load}} = 10 \text{ nF}$ ,<br>$I_{\text{Sink}} = C_{\text{Load}} * \text{slew rate} (= 50\%-20\% \text{ of } V_{\text{GHx1}})$ ,<br>$I_{\text{CHARGE}} = I_{\text{DISCHG}} = 31(\text{max})$ | P_12.1.79 |
| Source current - Charge current - Low Side Driver  | $I_{\text{Soumax\_LS}}$  | 200    | 295  | 375  | mA   | $V_{SD} \geq 8 \text{ V}$ , $C_{\text{Load}} = 10 \text{ nF}$ ,<br>$I_{\text{Sou}} = C_{\text{Load}} * \text{slew rate} (= 20\%-50\% \text{ of } V_{\text{GLx1}})$ ,<br>$I_{\text{CHARGE}} = I_{\text{DISCHG}} = 31(\text{max})$  | P_12.1.80 |
| Sink current - Discharge current-Low Side Driver   | $I_{\text{Sinkmax\_LS}}$ | 200    | 314  | 375  | mA   | $V_{SD} \geq 8 \text{ V}$ , $C_{\text{Load}} = 10 \text{ nF}$ ,<br>$I_{\text{Sink}} = C_{\text{Load}} * \text{slew rate} (= 50\%-20\% \text{ of } V_{\text{GHx1}})$ ,<br>$I_{\text{CHARGE}} = I_{\text{DISCHG}} = 31(\text{max})$ | P_12.1.81 |
| High level output voltage Gxx vs. Sxx              | $V_{\text{Gxx1}}$        | 10     | –    | 14   | V    | $V_{SD} \geq 8 \text{ V}$ , $C_{\text{Load}} = 10 \text{ nF}$ ,<br>$I_{\text{CP}}=2.5 \text{ mA}^2$ .   | P_12.1.3  |
| High level output voltage GHx vs. SHx              | $V_{\text{Gxx2}}$        | 8      | –    | –    | V    | $V_{SD} = 6.4 \text{ V}^1$ , $C_{\text{Load}} = 10 \text{ nF}$ ,<br>$I_{\text{CP}}=2.5 \text{ mA}^2$  | P_12.1.4  |
| High level output voltage GHx vs. SHx              | $V_{\text{Gxx3}}$        | 7      | –    | –    | V    | $V_{SD} = 5.4 \text{ V}$ , $C_{\text{Load}} = 10 \text{ nF}$ ,<br>$I_{\text{CP}}=2.5 \text{ mA}^2$  | P_12.1.5  |

**Electrical Characteristics**
**Table 42 Electrical Characteristics MOSFET Driver (cont'd)**
 $V_S = 5.5 \text{ V to } 28 \text{ V}$ ,  $T_j = -40 \text{ }^\circ\text{C to } +150 \text{ }^\circ\text{C}$ , all voltages with respect to ground, positive current flowing into pin (unless otherwise specified)

| Parameter   | Symbol                     | Values |      |      | Unit          | Note / Test Condition  | Number    |
|---|----------------------------|--------|------|------|---------------|--|-----------|
|   |                            | Min.   | Typ. | Max. |               |  |           |
| High level output voltage<br>GLx vs. GND            | $V_{Gxx6}$                 | 8      | –    | –    | V             | $V_{SD} = 6.4 \text{ V}^1$ , $C_{Load} = 10 \text{ nF}$ ,<br>$I_{CP} = 2.5 \text{ mA}^2$   | P_12.1.6  |
| High level output voltage<br>GLx vs. GND            | $V_{Gxx7}$                 | 7      | –    | –    | V             | $V_{SD} = 5.4 \text{ V}$ , $C_{Load} = 10 \text{ nF}$ ,<br>$I_{CP} = 2.5 \text{ mA}^2$   | P_12.1.7  |
| Rise time   | $t_{rise3\_3nf}$           | –      | 200  | –    | ns            | <sup>1)</sup> $C_{Load} = 3.3 \text{ nF}$ ,<br>$V_{SD} \geq 8 \text{ V}$ ,<br>25-75% of $V_{Gxx1}$ , $I_{CHARGE} =$<br>$I_{DISCHG} = 31(\text{max})$ | P_12.1.8  |
| Fall time   | $t_{fall3\_3nf}$           | –      | 200  | –    | ns            | <sup>1)</sup> $C_{Load} = 3.3 \text{ nF}$ ,<br>$V_{SD} \geq 8 \text{ V}$ ,<br>75-25% of $V_{Gxx1}$ , $I_{CHARGE} =$<br>$I_{DISCHG} = 31(\text{max})$ | P_12.1.9  |
| Rise time   | $t_{risemax}$              | 100    | 250  | 450  | ns            | $C_{Load} = 10 \text{ nF}$ ,<br>$V_{SD} \geq 8 \text{ V}$ ,<br>25-75% of $V_{Gxx1}$ , $I_{CHARGE} =$<br>$I_{DISCHG} = 31(\text{max})$                | P_12.1.57 |
| Fall time   | $t_{fallmax}$              | 100    | 250  | 450  | ns            | $C_{Load} = 10 \text{ nF}$ ,<br>$V_{SD} \geq 8 \text{ V}$ ,<br>75-25% of $V_{Gxx1}$ , $I_{CHARGE} =$<br>$I_{DISCHG} = 31(\text{max})$                | P_12.1.58 |
| Rise time   | $t_{risemin}$              | 1.25   | 2.5  | 5    | $\mu\text{s}$ | <sup>1)</sup> $C_{Load} = 10 \text{ nF}$ ,<br>$V_{SD} \geq 8 \text{ V}$ ,<br>25-75% of $V_{Gxx1}$ ,<br>$I_{CHARGE} = I_{DISCHG} = 3(\text{min})$     | P_12.1.14 |
| Fall time   | $t_{fallmin}$              | 1.25   | 2.5  | 5    | $\mu\text{s}$ | <sup>1)</sup> $C_{Load} = 10 \text{ nF}$ ,<br>$V_{SD} \geq 8 \text{ V}$ ,<br>75-25% of $V_{Gxx1}$ ,<br>$I_{CHARGE} = I_{DISCHG} = 3(\text{min})$     | P_12.1.15 |
| Absolute rise - fall time<br>difference for all LSx | $t_{r\_f(\text{diff})LSx}$ | –      | –    | 100  | ns            | $C_{Load} = 10 \text{ nF}$ ,<br>$V_{SD} \geq 8 \text{ V}$ ,<br>25-75% of $V_{Gxx1}$ , $I_{CHARGE} =$<br>$I_{DISCHG} = 31(\text{max})$                | P_12.1.35 |
| Absolute rise - fall time<br>difference for all HSx | $t_{r\_f(\text{diff})HSx}$ | –      | –    | 100  | ns            | $C_{Load} = 10 \text{ nF}$ ,<br>$V_{SD} \geq 8 \text{ V}$ ,<br>25-75% of $V_{Gxx1}$ , $I_{CHARGE} =$<br>$I_{DISCHG} = 31(\text{max})$                | P_12.1.36 |
| Resistor between GHx/GLx<br>and GND                 | $R_{GND}$                  | 30     | 40   | 50   | k $\Omega$    | <sup>1)</sup> –  | P_12.1.11 |

**Electrical Characteristics**
**Table 42 Electrical Characteristics MOSFET Driver (cont'd)**
 $V_S = 5.5 \text{ V to } 28 \text{ V}$ ,  $T_j = -40 \text{ }^\circ\text{C to } +150 \text{ }^\circ\text{C}$ , all voltages with respect to ground, positive current flowing into pin (unless otherwise specified)

| Parameter                               | Symbol                 | Values |      |      | Unit          | Note / Test Condition   | Number    |
|---|------------------------|--------|------|------|---------------|---|-----------|
|   |                        | Min.   | Typ. | Max. |               |   |           |
| Resistor between SHx and GND            | $R_{SHGN}$             | 30     | 40   | 50   | k $\Omega$    | <sup>1)3)</sup> This resistance is the resistance between GHx and GND connected through a diode to SHx. As a consequence, the voltage at SHx can rise up to 0,6V typ. before it is discharged through the resistor. | P_12.1.10 |
| Low RDSON mode (boosted discharge mode) | $R_{ONCCP}$            | –      | 9    | 12   | $\Omega$      | $V_{VSD} = 13.5 \text{ V}$ ,<br>$V_{VCP} = V_{VSD} + 14.0 \text{ V}$ ;<br>$I_{CHARGE} = I_{DISCHG} = 31(\text{max})$ ; 50mA forced into Gx, Sx grounded   | P_12.1.50 |
| Resistance between VDH and VSD          | $I_{BSH}$              | –      | 4    | –    | k $\Omega$    | <sup>1)</sup>   | P_12.1.24 |
| Input propagation time (LS on)          | $t_{P(ILN)\text{min}}$ | –      | 1.5  | 3    | $\mu\text{s}$ | <sup>1)</sup> $C_{Load} = 10 \text{ nF}$ ,<br>$I_{Charge} = 3(\text{min})$ ,<br>25% of $V_{Gxx1}$   | P_12.1.37 |
| Input propagation time (LS off)         | $t_{P(ILF)\text{min}}$ | –      | 1.5  | 3    | $\mu\text{s}$ | <sup>1)</sup> $C_{Load} = 10 \text{ nF}$ ,<br>$I_{Discharge} = 3(\text{min})$ ,<br>75% of $V_{Gxx1}$  | P_12.1.38 |
| Input propagation time (HS on)          | $t_{P(IHN)\text{min}}$ | –      | 1.5  | 3    | $\mu\text{s}$ | <sup>1)</sup> $C_{Load} = 10 \text{ nF}$ ,<br>$I_{Charge} = 3(\text{min})$ ,<br>25% of $V_{Gxx1}$   | P_12.1.39 |
| Input propagation time (HS off)         | $t_{P(IHF)\text{min}}$ | –      | 1.5  | 3    | $\mu\text{s}$ | <sup>1)</sup> $C_{Load} = 10 \text{ nF}$ ,<br>$I_{Discharge} = 3(\text{min})$ ,<br>75% of $V_{Gxx1}$  | P_12.1.40 |
| Input propagation time (LS on)          | $t_{P(ILN)\text{max}}$ | –      | 200  | 350  | ns            | $C_{Load} = 10 \text{ nF}$ ,<br>$I_{Charge} = 31(\text{max})$ ,<br>25% of $V_{Gxx1}$  | P_12.1.26 |
| Input propagation time (LS off)         | $t_{P(ILF)\text{max}}$ | –      | 200  | 300  | ns            | $C_{Load} = 10 \text{ nF}$ ,<br>$I_{Discharge} = 31(\text{max})$ ,<br>75% of $V_{Gxx1}$   | P_12.1.27 |
| Input propagation time (HS on)          | $t_{P(IHN)\text{max}}$ | –      | 200  | 350  | ns            | $C_{Load} = 10 \text{ nF}$ ,<br>$I_{Charge} = 31(\text{max})$ ,<br>25% of $V_{Gxx1}$  | P_12.1.28 |
| Input propagation time (HS off)         | $t_{P(IHF)\text{max}}$ | –      | 200  | 300  | ns            | $C_{Load} = 10 \text{ nF}$ ,<br>$I_{Discharge} = 31(\text{max})$ ,<br>75% of $V_{Gxx1}$   | P_12.1.29 |

**Electrical Characteristics**
**Table 42 Electrical Characteristics MOSFET Driver (cont'd)**
 $V_S = 5.5 \text{ V to } 28 \text{ V}$ ,  $T_j = -40 \text{ }^\circ\text{C to } +150 \text{ }^\circ\text{C}$ , all voltages with respect to ground, positive current flowing into pin (unless otherwise specified)

| Parameter  | Symbol                     | Values |      |      | Unit | Note / Test Condition  | Number    |
|--|----------------------------|--------|------|------|------|--|-----------|
|  |                            | Min.   | Typ. | Max. |      |  |           |
| Absolute input propagation time difference between propagation times for all LSx (LSx on)  | $t_{\text{Pon(diff)LSx}}$  | –      | –    | 100  | ns   | $C_{\text{Load}} = 10 \text{ nF}$ ,<br>$I_{\text{Charge}} = 31(\text{max})$ ,<br>25% of $V_{\text{Gxx1}}$    | P_12.1.30 |
| Absolute input propagation time difference between propagation times for all LSx (LSx off) | $t_{\text{Poff(diff)LSx}}$ | –      | –    | 100  | ns   | $C_{\text{Load}} = 10 \text{ nF}$ ,<br>$I_{\text{Discharge}} = 31(\text{max})$ ,<br>75% of $V_{\text{Gxx1}}$ | P_12.1.41 |
| Absolute input propagation time difference between propagation times for all HSx (HSx on)  | $t_{\text{Pon(diff)HSx}}$  | –      | –    | 100  | ns   | $C_{\text{Load}} = 10 \text{ nF}$ ,<br>$I_{\text{Charge}} = 31(\text{max})$ ,<br>25% of $V_{\text{Gxx1}}$    | P_12.1.42 |
| Absolute input propagation time difference between propagation times for all HSx (HSx off) | $t_{\text{Poff(diff)HSx}}$ | –      | –    | 100  | ns   | $C_{\text{Load}} = 10 \text{ nF}$ ,<br>$I_{\text{Discharge}} = 31(\text{max})$ ,<br>75% of $V_{\text{Gxx1}}$ | P_12.1.43 |

**Drain source monitoring**

|                                   |                       |      |      |       |   |                                 |           |     |
|-----------------------------------|-----------------------|------|------|-------|---|---------------------------------|-----------|-----|
| Drain source monitoring threshold | $V_{\text{DSMONVTH}}$ | –    | –    | –     | V | DRV_CTRL3.DSMONVT<br>H<2:0> xxx | P_12.1.46 |     |
|                                   |                       | 0.07 | 0.25 | 0.40  |   |                                 |           | 000 |
|                                   |                       | 0.35 | 0.50 | 0.650 |   |                                 |           | 001 |
|                                   |                       | 0.55 | 0.75 | 0.90  |   |                                 |           | 010 |
|                                   |                       | 0.65 | 1.00 | 1.25  |   |                                 |           | 011 |
|                                   |                       | 0.90 | 1.25 | 1.45  |   |                                 |           | 100 |
|                                   |                       | 1.00 | 1.5  | 1.80  |   |                                 |           | 101 |
|                                   |                       | 1.20 | 1.75 | 2.10  |   |                                 |           | 110 |
|                                   |                       | 1.40 | 2.00 | 2.40  |   |                                 |           | 111 |

**Open load diagnosis currents**

|                             |                     |      |      |      |               |  |           |
|-----------------------------|---------------------|------|------|------|---------------|--|-----------|
| Pull-up diagnosis current   | $I_{\text{PUDiag}}$ | -220 | -370 | -520 | $\mu\text{A}$ | $I_{\text{DISCHG}} = 1$ ; $V_{\text{SHx}} = 5.0 \text{ V}$ | P_12.1.47 |
| Pull-down diagnosis current | $I_{\text{PDDiag}}$ | 650  | 900  | 1100 | $\mu\text{A}$ | $I_{\text{DISCHG}} = 1$ ; $V_{\text{SHx}} = 5.0 \text{ V}$ | P_12.1.48 |

**Charge pump**

|                                      |                     |     |    |    |   |  |           |
|--------------------------------------|---------------------|-----|----|----|---|--|-----------|
| Output voltage VCP vs. VSD           | $V_{\text{CPmin1}}$ | 8.5 | –  | –  | V | $V_{\text{VSD}} = 5.4\text{V}$ ,<br>$I_{\text{CP}} = 5 \text{ mA}$ ,<br>$C_{\text{CP1}}, C_{\text{CP2}} = 220 \text{ nF}$ ,<br>Bridge Driver enabled                     | P_12.1.53 |
| Regulated output voltage VCP vs. VSD | $V_{\text{CP}}$     | 12  | 14 | 16 | V | $8 \text{ V} \leq V_{\text{VSD}} \leq 28$ ,<br>$I_{\text{CP}} = 10\text{mA}$ ,<br>$C_{\text{CP1}}, C_{\text{CP2}} = 220 \text{ nF}$ ,<br>$f_{\text{CP}} = 250\text{kHz}$ | P_12.1.49 |



**Table 42 Electrical Characteristics MOSFET Driver (cont'd)**

$V_S = 5.5 \text{ V to } 28 \text{ V}$ ,  $T_j = -40 \text{ °C to } +150 \text{ °C}$ , all voltages with respect to ground, positive current flowing into pin (unless otherwise specified)

| Parameter    | Symbol                 | Values |      |      | Unit | Note / Test Condition   | Number    |
|--------------|------------------------|--------|------|------|------|---|-----------|
|              |                        | Min.   | Typ. | Max. |      |   |           |
| Turn ON Time | $t_{\text{ON\_VCP}}$   | 10     | 24   | 40   | us   | $8 \text{ V} \leq V_{\text{VSD}} \leq 28$ ,<br>$I_{\text{CP}}=2.5\text{mA}$ ,<br>(25%) of $V_{\text{CP}}^{1)4)}$ ,<br>$C_{\text{CP1}}, C_{\text{CP2}}=220 \text{ nF}$ ,<br>$f_{\text{CP}}=250\text{kHz}$    | P_12.1.59 |
| Rise time    | $t_{\text{rise\_VCP}}$ | 20     | 60   | 88   | us   | $8 \text{ V} \leq V_{\text{VSD}} \leq 28$ ,<br>$I_{\text{CP}}=2.5\text{mA}$ ,<br>(25-75%) of $V_{\text{CP}}^{1)5)}$ ,<br>$C_{\text{CP1}}, C_{\text{CP2}}=220 \text{ nF}$ ,<br>$f_{\text{CP}}=250\text{kHz}$ | P_12.1.60 |

- 1) Not subject to production test.
- 2) The condition  $I_{\text{CP}}=2,5 \text{ mA}$  emulates anH-Bridge Driver with 4 MOSFET switching at 20 KHz with a  $C_{\text{Load}}=3.3\text{nF}$ . Test condition:  $I_{\text{Gx}} = -100 \mu\text{A}$ ,  $\text{ICHARGE} = \text{IDISCHARGE} = 31(\text{max})$ ,  $\text{IDISCHARGEDIV2\_N} = 1$  and  $\text{ICHARGEDIV2\_N} = 1$ .
- 3) This resistance is connected through a diode between SHx and GHx to ground.
- 4) This time applies when Bit  $\text{DRV\_CP\_CTRL\_STS.bit.CP\_EN}$  is set
- 5) This time applies when Bit  $\text{DRV\_CP\_CLK\_CTRL.bit.CPCLK\_EN}$  is set

**29.13 Operational Amplifier**
**29.13.1 Electrical Characteristics**
**Table 43 Electrical Characteristics Operational Amplifier**

$V_S = 5.5 \text{ V to } 28 \text{ V}$ ,  $T_j = -40 \text{ }^\circ\text{C to } +150 \text{ }^\circ\text{C}$ ; all voltages with respect to ground, positive current flowing into pin (unless otherwise specified)

| Parameter   | Symbol        | Values                |                      |                        | Unit | Note / Test Condition  | Number    |
|---|---------------|-----------------------|----------------------|------------------------|------|--|-----------|
|   |               | Min.                  | Typ.                 | Max.                   |      |  |           |
| Differential gain (uncalibrated)  | $G$           | 9.5<br>19<br>38<br>57 | 10<br>20<br>40<br>60 | 10.5<br>21<br>42<br>63 |      | Gain settings GAIN<1:0>:<br>00<br>01<br>10<br>11   | P_13.1.6  |
| Differential input operating voltage range OP2 - OP1                                    | $V_{IX}$      | -1.5 / G              | –                    | 1.5 / G                | V    | G is the Gain specified below  | P_13.1.1  |
| Operating. common mode input voltage range (referred to GND (OP2 - GND) or (OP1 - GND)) | $V_{CM}$      | -2.0                  | –                    | 2.0                    | V    | Input common mode has to be checked in evaluation if it fits the required range  | P_13.1.2  |
| Max. input voltage range (referred to GND (OP_2 - GND) or (OP1 - GND))                  | $V_{IX\_max}$ | -7.0                  | –                    | 7.0                    | V    | Max. rating of operational amplifier inputs, where measurement is not done   | P_13.1.3  |
| Single ended output voltage range (linear range)  | $V_{OUT}$     | $V_{ZERO} - 1.5$      | –                    | $V_{ZERO} + 1.5$       | V    | <sup>1)2)</sup> typ. output offset voltage $2 \text{ V} \pm 1.5\text{V}$   | P_13.1.4  |
| Linearity error   | $E_{PWM}$     | -15                   | –                    | 15                     | mV   | Maximum deviation from best fit straight line divided by max. value of differential output voltage range (0.5V - 3.5V); this parameter is determined at $G = 10$ . | P_13.1.5  |
| Linearity error   | $E_{PWM\%}$   | -1.0                  | –                    | 1.0                    | %    | Maximum deviation from best fit straight line divided by max. value of differential output voltage range (0.5V - 3.5V); this parameter is determined at $G = 10$ . | P_13.1.24 |
| Gain drift  |               | -1                    | –                    | 1                      | %    | Gain drift after calibration at $G = 10$ .   | P_13.1.7  |
| Adjusted output offset voltage  | $V_{OOS}$     | -40                   | 10                   | 40                     | mV   | $V_{AIP} = V_{AIN} = 0 \text{ V}$ and $G = 40$ .   | P_13.1.17 |

**Electrical Characteristics**
**Table 43 Electrical Characteristics Operational Amplifier (cont'd)**
 $V_S = 5.5 \text{ V to } 28 \text{ V}$ ,  $T_j = -40 \text{ }^\circ\text{C to } +150 \text{ }^\circ\text{C}$ ; all voltages with respect to ground, positive current flowing into pin (unless otherwise specified)

| Parameter   | Symbol                    | Values |      |      | Unit       | Note / Test Condition   | Number    |
|---|---------------------------|--------|------|------|------------|---|-----------|
|   |                           | Min.   | Typ. | Max. |            |   |           |
| DC input voltage common mode rejection ratio        | DC-CMRR                   | 58     | 80   | –    | dB         | CMRR (in dB) = $-20 \cdot \log$ (differential mode gain / common mode gain)<br>$V_{\text{CMI}} = -2\text{V} \dots 2\text{V}$ ,<br>$V_{\text{AIP}} - V_{\text{AIN}} = 0\text{V}$ | P_13.1.8  |
| Settling time to 98%                                | $T_{\text{SET}}$          | –      | 800  | 1400 | ns         | Derived from 80 - 20 % rise fall times for $\pm 2\text{V}$ overload condition (3 Tau value of settling time constant) <sup>2)</sup>   | P_13.1.9  |
| Current Sense Amplifier Input Resistance @ OP1, OP2 | $R_{\text{in\_OP1\_OP2}}$ | 1      | 1.25 | 1.5  | k $\Omega$ | <sup>2)</sup> –   | P_13.1.25 |

### 30 Package Outlines

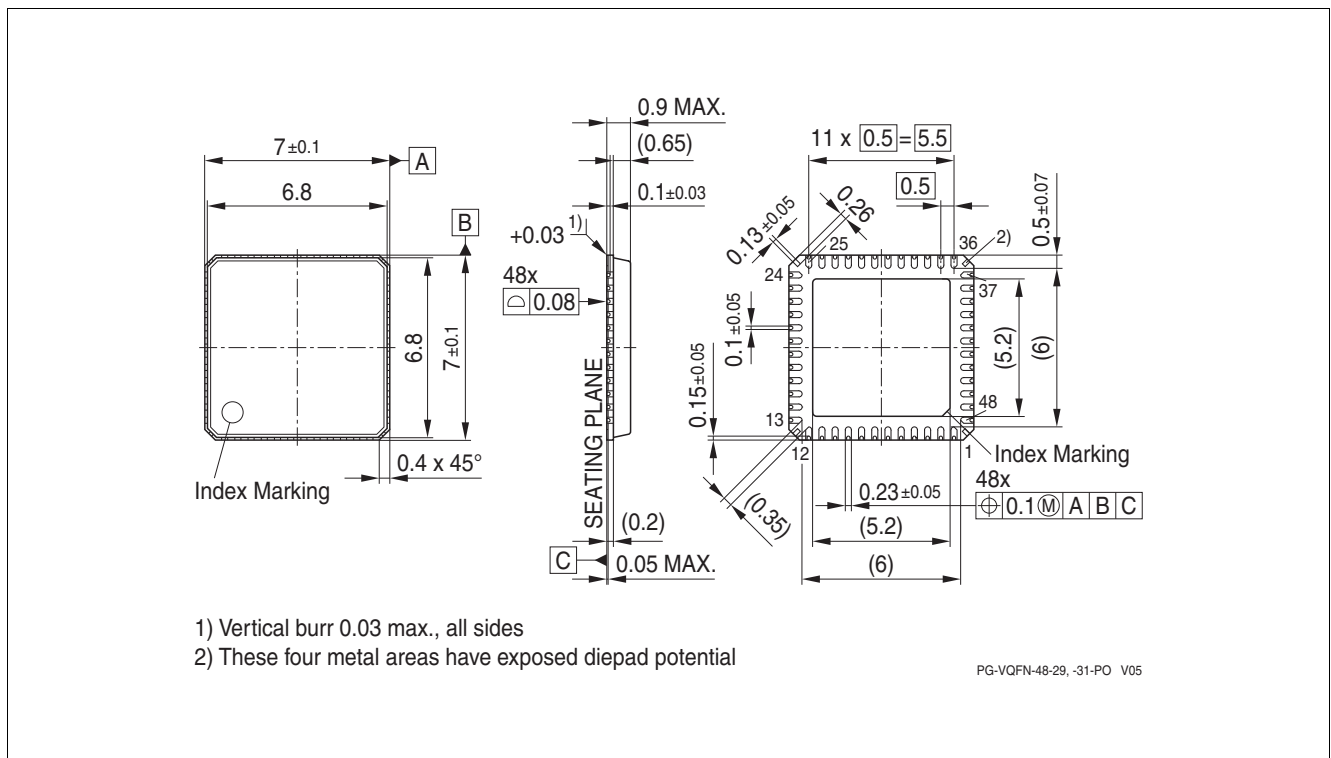

Figure 37 Package outline VQFN-48-31 (with LTI)

#### Notes

1. You can find all of our packages, sorts of packing and others in our Infineon Internet Page "Products":  
<http://www.infineon.com/products>.
2. Dimensions in mm.

## 31 Revision History

| Revision History     |  |
|----------------------|--|
| Page or Item         | Subjects (major changes since previous revision) |
| Rev. 1.0, 2017-03-03 |  |
| All                  | Initial release.                                 |

#### Trademarks of Infineon Technologies AG

$\mu$ HVIC™,  $\mu$ IPM™,  $\mu$ PFC™, AU-ConvertIR™, AURIX™, C166™, CanPAK™, CIPOS™, CIPURSE™, CoolDP™, CoolGaN™, COOLiR™, CoolMOS™, CoolSET™, CoolSiC™, DAVE™, DI-POL™, DirectFET™, DrBlade™, EasyPIM™, EconoBRIDGE™, EconoDUAL™, EconoPACK™, EconoPIM™, EiceDRIVER™, eupec™, FCOS™, GaNpowIR™, HEXFET™, HITFET™, HybridPACK™, iMOTION™, IRAM™, ISOFACE™, IsoPACK™, LEDriviR™, LITIX™, MIPAQ™, ModSTACK™, my-d™, NovalithIC™, OPTIGA™, OptiMOS™, ORIGA™, PowIRaudio™, PowIRstage™, PrimePACK™, PrimeSTACK™, PROFET™, PRO-SIL™, RASIC™, REAL3™, SmartLEWIS™, SOLID FLASH™, SPOC™, StrongIRFET™, SupIRBuck™, TEMPFET™, TRENCHSTOP™, TriCore™, UHVIC™, XHP™, XMC™.

Trademarks updated November 2015

#### Other Trademarks

All referenced product or service names and trademarks are the property of their respective owners.

**Edition 2017-03-03**

**Published by**

**Infineon Technologies AG**

**81726 Munich, Germany**

**© 2017 Infineon Technologies AG.**

**All Rights Reserved.**

**Do you have a question about any aspect of this document?**

**Email: [erratum@infineon.com](mailto:erratum@infineon.com)**

#### IMPORTANT NOTICE

The information given in this document shall in no event be regarded as a guarantee of conditions or characteristics ("Beschaffheitsgarantie").

With respect to any examples, hints or any typical values stated herein and/or any information regarding the application of the product, Infineon Technologies hereby disclaims any and all warranties and liabilities of any kind, including without limitation warranties of non-infringement of intellectual property rights of any third party.

In addition, any information given in this document is subject to customer's compliance with its obligations stated in this document and any applicable legal requirements, norms and standards concerning customer's products and any use of the product of Infineon Technologies in customer's applications.

The data contained in this document is exclusively intended for technically trained staff. It is the responsibility of customer's technical departments to evaluate the suitability of the product for the intended application and the completeness of the product information given in this document with respect to such application.

For further information on technology, delivery terms and conditions and prices, please contact the nearest Infineon Technologies Office ([www.infineon.com](http://www.infineon.com)).

#### WARNINGS

Due to technical requirements products may contain dangerous substances. For information on the types in question please contact your nearest Infineon Technologies office.

Except as otherwise explicitly approved by Infineon Technologies in a written document signed by authorized representatives of Infineon Technologies, Infineon Technologies' products may not be used in any applications where a failure of the product or any consequences of the use thereof can reasonably be expected to result in personal injury.

## Данный компонент на территории Российской Федерации

### Вы можете приобрести в компании MosChip.

Для оперативного оформления запроса Вам необходимо перейти по данной ссылке:

<http://moschip.ru/get-element>

Вы можете разместить у нас заказ для любого Вашего проекта, будь то серийное производство или разработка единичного прибора.

В нашем ассортименте представлены ведущие мировые производители активных и пассивных электронных компонентов.

Нашей специализацией является поставка электронной компонентной базы двойного назначения, продукции таких производителей как XILINX, Intel (ex.ALTERA), Vicor, Microchip, Texas Instruments, Analog Devices, Mini-Circuits, Amphenol, Glenair.

Сотрудничество с глобальными дистрибьюторами электронных компонентов, предоставляет возможность заказывать и получать с международных складов практически любой перечень компонентов в оптимальные для Вас сроки.

На всех этапах разработки и производства наши партнеры могут получить квалифицированную поддержку опытных инженеров.

Система менеджмента качества компании отвечает требованиям в соответствии с ГОСТ Р ИСО 9001, ГОСТ РВ 0015-002 и ЭС РД 009

### Офис по работе с юридическими лицами:

105318, г.Москва, ул.Щербаковская д.3, офис 1107, 1118, ДЦ «Щербаковский»

Телефон: +7 495 668-12-70 (многоканальный)

Факс: +7 495 668-12-70 (доб.304)

E-mail: [info@moschip.ru](mailto:info@moschip.ru)

Skype отдела продаж:

moschip.ru

moschip.ru\_4

moschip.ru\_6

moschip.ru\_9