

WVGA/LCD EI3 Extender Board Manual

an EZ-Extender® product

Revision 1.0, April 2012

Part Number
82-000254-01

Analog Devices, Inc.
One Technology Way
Norwood, Mass. 02062-9106



Copyright Information

©2012 Analog Devices, Inc., ALL RIGHTS RESERVED. This document may not be reproduced in any form without prior, express written consent from Analog Devices, Inc.

Printed in the USA.

Disclaimer

Analog Devices, Inc. reserves the right to change this product without prior notice. Information furnished by Analog Devices is believed to be accurate and reliable. However, no responsibility is assumed by Analog Devices for its use; nor for any infringement of patents or other rights of third parties which may result from its use. No license is granted by implication or otherwise under the patent rights of Analog Devices, Inc.

Trademark and Service Mark Notice

The Analog Devices logo, CrossCore, Blackfin, EZ-KIT Lite, EZ-Board, and EZ-Extender are registered trademarks of Analog Devices, Inc.

EngineerZone is a trademark of Analog Devices, Inc.

All other brand and product names are trademarks or service marks of their respective owners.

Regulatory Compliance

The WVGA/LCD EI3 Extender Board is designed to be used solely in a laboratory environment. The board is not intended for use as a consumer end product or as a portion of a consumer end product. The board is an open system design which does not include a shielded enclosure and therefore may cause interference to other electrical devices in close proximity. This board should not be used in or near any medical equipment or RF devices.

The WVGA/LCD EI3 Extender Board is in the process of being certified to comply with the essential requirements of the European EMC directive 89/336/EEC (inclusive 93/68/EEC) and, therefore, carries the “CE” mark.



The extender board contains ESD (electrostatic discharge) sensitive devices. Electrostatic charges readily accumulate on the human body and equipment and can discharge without detection. Permanent damage may occur on devices subjected to high-energy discharges. Proper ESD precautions are recommended to avoid performance degradation or loss of functionality. Store unused extender boards in the protective shipping package.



CONTENTS

PREFACE

Product Overview	vii
Purpose of This Manual	viii
Intended Audience	ix
Manual Contents	ix
What's New in This Manual	x
Technical Support	x
Supported Processors	xi
Product Information	xi
Analog Devices Web Site	xii
EngineerZone	xii
Related Documents	xiii

USING WVGA/LCD EI3 EXTENDER BOARD

Package Contents	1-2
Supported Operating Systems	1-2
System Requirements	1-3
Extender Board Installation	1-3
LCD	1-4

Contents

LCD Touch Controller (AD7879)	1-5
Capacitive Touch Controller (AD7147)	1-5
Digital Accelerometer (ADXL345)	1-6
Expansion Interface III	1-7
Example Programs	1-7
Board Design Database	1-8

WVGA/LCD EI3 EXTENDER BOARD HARDWARE REFERENCE

System Architecture	2-2
Software-Controlled Switches (SoftConfig)	2-3
Overview of SoftConfig	2-3
Programming SoftConfig on the WVGA/LCD EI3 Extender Board	2-7
LCD SPI Chip Select	2-13
PPICLK_DIR Select	2-13
LCD Mode Select	2-13
AD7879 PENIRQ Signal	2-13
AD7879 SPI Chip Select	2-14
AD7147 Interrupt Signal	2-14
ADXL345 Interrupt Signals	2-14
ADXL345 TWI/SPI Mode Select	2-14
ADXL345 SPI Chip Select	2-15
Connectors	2-16
Expansion Interface III (EI3) Connectors (J1–2)	2-17

Expansion Interface III (EI3) Connectors (P1–2)	2-17
Power Connector (P4)	2-17
LCD Connector (P5)	2-18
Power LED (LED1)	2-18

WVGA/LCD EI3 EXTENDER BOARD BILL OF MATERIALS

WVGA/LCD EI3 EXTENDER BOARD SCHEMATIC

Title Page	B-1
EI3 Connectors/GPIO Extender	B-2
EI3 Unused Connectors	B-3
Buffers/Clock/Pull-Ups	B-4
Soft Config and Reset	B-5
LCD Connector and Mode Switches	B-6
Accelerometer/Touch Screen/Cap Touch/Power	B-7
TWI/SPI Flash	B-8

INDEX

PREFACE

Thank you for purchasing the WVGA/LCD EI3 Extender Board, an EZ-Extender[®] for EZ-KIT Lite[®]/EZ-Board[®] evaluation systems with the Expansion Interface III (EI3).

The EZ-KIT Lite/EZ-Board and WVGA/LCD EI3 Extender Board are designed to be used in conjunction with the CrossCore[®] Embedded Studio (CCES) development environment.

To learn more about Analog Devices development software, go to <http://www.analog.com/processors/tools/>.

Product Overview

The WVGA/LCD EI3 Extender Board is a separately sold daughter board that plugs onto the IE3 of an EZ-KIT Lite/EZ-Board evaluation system. The extender board aids the design and prototyping phases of embedded processor-targeted applications.

The board extends the capabilities of the evaluation system by providing a connection between the parallel peripheral interface (PPI) of the processor and on-board 4.1 inch liquid crystal display (LCD). The serial peripheral interface (SPI) and two-wire interface (TWI) of the processor are used to communicate with the LCD, AD7879 touch screen controller, AD7147 capacitive touch controller, and ADXL345 digital accelerometer on the extender.

Purpose of This Manual

The product features:

- LCD with touch screen
 - NEC NL8048HL11-01B 4.1 inch WVGA LCD with resistive touch
 - 800 (horizontal) x 480 (vertical) landscape
 - LCD backlight
- LCD touch screen controller
 - Analog Devices AD7879 touch screen controller
- Capacitive touch controller
 - Analog Devices AD7147 capacitive touch controller
 - Four push buttons and one scroll wheel
- Digital accelerometer
 - Analog Devices ADXL345 3-axis digital accelerometer
- Software-controlled switches for board configuration
- Expansion Interface III
- No power supply required: derives power from the EZ-KIT Lite/EZ-Board
- CE certified

Purpose of This Manual

The *WVGA/LCD EI3 Extender Board Manual* provides instructions for installing the product hardware (board). The text describes operation and configuration of the board components and provides guidelines for run-

ning your own code on the WVGA/LCD EI3 Extender Board. Finally, a schematic and a bill of materials are provided for reference.

Intended Audience

The primary audience for this manual is a programmer who is familiar with Analog Devices processors. This manual assumes that the audience has a working knowledge of the appropriate processor architecture, instruction set, and C/C++ programming languages.

Programmers who are unfamiliar with Analog Devices processors can use this manual, but should supplement it with other texts that describe your target architecture and hardware development tools.

Programmers who are unfamiliar with the CrossCore Embedded Studio programming environment or the mating evaluation board, should refer to the CCES online help or the manual describing the board (see [“Related Documents”](#)).

Manual Contents

The manual consists of:

- Chapter 1, [“Using WVGA/LCD EI3 Extender Board”](#) on page 1-1
Provides basic product information.
- Chapter 2, [“WVGA/LCD EI3 Extender Board Hardware Reference”](#) on page 2-1.
Provides information about the product’s hardware components.

What's New in This Manual

- Appendix A, “[WVGA/LCD EI3 Extender Board Bill Of Materials](#)” on [page A-1](#)
Provides a list of hardware components used to manufacture the board.
- Appendix B, “[WVGA/LCD EI3 Extender Board Schematic](#)” on [page B-1](#)
Provides all of the circuits on the extender board.

What's New in This Manual

This is the first revision of the *WVGA/LCD EI3 Extender Board Manual*.

Technical Support

You can reach Analog Devices processors and DSP technical support in the following ways:

- Post your questions in the processors and DSP support community at EngineerZone™:
<http://ez.analog.com/community/dsp>
- Submit your questions to technical support directly at:
<http://www.analog.com/support>
- E-mail your questions about processors, DSPs, and tools development software from **CrossCore Embedded Studio** or **VisualDSP++**:

Choose **Help > Email Support**. This creates an e-mail to processor.tools.support@analog.com and automatically attaches your **CrossCore Embedded Studio** or **VisualDSP++** version information and `license.dat` file.

- E-mail your questions about processors and processor applications to:
processor.support@analog.com or
processor.china@analog.com (Greater China support)
- In the **USA only**, call 1-800-ANALOGD (1-800-262-5643)
- Contact your Analog Devices sales office or authorized distributor. Locate one at:
www.analog.com/adi-sales
- Send questions by mail to:
Processors and DSP Technical Support
Analog Devices, Inc.
Three Technology Way
P.O. Box 9106
Norwood, MA 02062-9106
USA

Supported Processors

This extender board supports EZ-KIT Lite/EZ-Board evaluation systems with IE3.

Product Information

Product information can be obtained from the Analog Devices Web site and CCES online help system.

Product Information

Analog Devices Web Site

The Analog Devices Web site, www.analog.com, provides information about a broad range of products— analog integrated circuits, amplifiers, converters, and digital signal processors.

To access a complete technical library for each processor family, go to http://www.analog.com/processors/technical_library. The manuals selection opens a list of current manuals related to the product as well as a link to the previous revisions of the manuals. When locating your manual title, note a possible errata check mark next to the title that leads to the current correction report against the manual.

Also note, MyAnalog.com is a free feature of the Analog Devices Web site that allows customization of a Web page to display only the latest information about products you are interested in. You can choose to receive weekly e-mail notifications containing updates to the Web pages that meet your interests, including documentation errata against all manuals. MyAnalog.com provides access to books, application notes, data sheets, code examples, and more.

Visit MyAnalog.com to sign up. If you are a registered user, just log on. Your user name is your e-mail address.

EngineerZone

EngineerZone is a technical support forum from Analog Devices. It allows you direct access to ADI technical support engineers. You can search FAQs and technical information to get quick answers to your embedded processing and DSP design questions.

Use EngineerZone to connect with other DSP developers who face similar design challenges. You can also use this open forum to share knowledge and collaborate with the ADI support team and your peers. Visit <http://ez.analog.com> to sign up.

Related Documents

For additional information about the product, refer to the following publications.

Table 1. Related Processor Publications

Title	Description
<i>Processor Data Sheet</i>	General functional description, pinout, and timing of the processor.
<i>Processor Hardware Reference</i>	Description of the internal processor architecture and all register functions.
<i>Blackfin Processor Programming Reference</i>	Description of all allowed processor assembly instructions.

Table 2. Related CCES Publications

Title	Description
<i>ADSP-BF609 EZ-KIT Lite Evaluation System Manual</i>	Description of the boards' interfaces and hardware components.
<i>CrossCore Embedded Studio Licensing Guide</i>	Description of the product's licensing options, installation, and activation.
<i>CrossCore Embedded Studio Assembler and Pre-processor Manual</i>	Description of the assembler functions and commands.
<i>CrossCore Embedded Studio C/C++ Compiler and Library Manual for Blackfin Processors</i>	Description of the compiler functions and commands for Blackfin processors.
<i>CrossCore Embedded Studio Linker and Utilities Manual</i>	Description of the linker functions and commands.
<i>CrossCore Embedded Studio Loader and Utilities Manual</i>	Description of the loader/splitter functions and commands.

Related Documents

1 USING WVGA/LCD EI3 EXTENDER BOARD

This chapter provides the setup procedure for the WVGA/LCD EI3 Extender Board and evaluation board and describes the interfaces the extender supports.

The information is presented in the following order.

- [“Package Contents” on page 1-2](#)
- [“Supported Operating Systems” on page 1-2](#)
- [“System Requirements” on page 1-3](#)
- [“Extender Board Installation” on page 1-3](#)
- [“LCD” on page 1-4](#)
- [“LCD Touch Controller \(AD7879\)” on page 1-5](#)
- [“Capacitive Touch Controller \(AD7147\)” on page 1-5](#)
- [“Digital Accelerometer \(ADXL345\)” on page 1-6](#)
- [“Expansion Interface III” on page 1-7](#)
- [“Example Programs” on page 1-7](#)
- [“Board Design Database” on page 1-8](#)

For information about the CCES integrated development environment (IDE), refer to the online help.

Package Contents

Your WVGA/LCD EI3 Extender Board package contains the following items.

- WVGA/LCD EI3 extender board
- A bag containing hardware for securing the extender board onto the EZ-KIT Lite/EZ-Board
- Release notes containing information about the product download

Contact the vendor where you purchased your extender board or contact Analog Devices, Inc. if any item is missing.

Supported Operating Systems

CCES is supported on the following operating systems:

- Windows[®] XP Professional SP3 (32-bit only)
- Windows Vista[™] Business, Enterprise, or Ultimate SP2 (32-bit only)
- Windows 7 Professional, Enterprise, or Ultimate (32- and 64-bit)



Windows Vista and Windows 7 users may experience User Access Control (UAC) related errors if the software is installed into a protected location, such as Program Files or Program Files (x86). We recommend installing the software in a non-UAC-protected location.

System Requirements

Verify that your PC has these minimum requirements for the CCES installation:

- 2 GHz single-core processor
- 1 GB RAM
- 8 GB available disk space
- One open USB port



A faster disk drive decreases the build time, especially for a large amount of source files .

Extender Board Installation

Follow these instructions to ensure correct operation of the product hardware and software.

1. Attach the extender board to the EZ-KIT Lite/EZ-Board.

The J1 connector on the extender board can be connected to the P1A, P2A, or P3A connector on the EZ-KIT Lite/EZ-Board. Refer to the example program for a reference to the proper connector.

2. Use the provided hardware to secure the extender to the EZ-KIT Lite/EZ-Board.

Insert the screws through the top of the board and screw into the

LCD

standoff on the bottom side of the board. Insert the plastic spacers between the bottom side of the EZ-KIT Lite/EZ-Board and to the top side of the extender.

3. Connect the EZ-KIT Lite/EZ-Board to a personal computer (PC) running CCES with the product BSP. Refer to the EZ-KIT Lite/EZ-Board manual for instructions.

LCD

The WVGA/LCD EI3 Extender Board is shipped with a NEC 4.1 inch WVGA (800 x 480) liquid crystal display (LCD) with backlight. All of the LCD data, touch screen pins, and power pins connect to the display via a single connector (P5). The 24-bit display connects to the processor via the processor's parallel peripheral interface (PPI).

The extender can be configured for 16-bit mode (RGB 565), 18-bit mode (RGB 666), or 24-bit mode (RGB 888) operation. The configuration is performed via a software switch (see [“LCD Mode Select” on page 2-13](#)) and [“WVGA/LCD EI3 Extender Board Schematic” on page B-1](#)).

The display also uses the serial peripheral interface (SPI) of the processor for register configurations.

The clock signal used for the LCD can be connected to the on-board oscillator or generated from the processor (see [“PPICLK_DIR Select” on page 2-13](#) for more information).

The LCD backlight circuit is controlled via a GPIO signal on the AD7879 touch screen controller.

For more information about the LCD, go to the NEC Web site.

An example program demonstrating capabilities of the LCD is available by installing the WVGA/LCD EI3 Extender Board BSP.

LCD Touch Controller (AD7879)

The WVGA/LCD EI3 Extender Board is equipped with an Analog Devices resistive touch controller (AD7879). The AD7879 controller is connected to the LCD touch screen via four pins (X+, X-, Y+, Y-). You can access the controller via the SPI of the processor. The controller generates an interrupt request for the processor whenever the user touches the LCD. The processor uses the SPI to read the appropriate registers on the controller.

An interrupt signal from the AD7879 controller is connected to a GPIO signal of the processor. The GPIO signal is configured via a software switch. The SPI is used for communications between the controller and processor; the SPI signals are configured via software as well. Refer to “AD7879 PENIRQ Signal” and “AD7879 SPI Chip Select” on page 2-14 for details.

For more information about the AD7879 touch controller, go to www.analog.com and search for AD7879.

An example program demonstrating capabilities of the touch controller is available by installing the product BSP.

Capacitive Touch Controller (AD7147)

The WVGA/LCD EI3 Extender Board is equipped with an Analog Devices CapTouch[®] programmable controller (AD7147) for applications implementing push buttons and scroll wheels. The four push button sensors and one scroll wheel are located on the top side of the extender’s printed circuit board (PCB).

The AD7147 controller generates an interrupt request for the processor whenever a user touches the push button or the scroll wheel. The two-wire interface (TWI) is used for communications between the controller and

Digital Accelerometer (ADXL345)

processor. The push buttons and scroll wheel are copper pads on the PCB. Touch the respective button or traverse around the wheel with a finger to enable sensor pads and generate an interrupt request. An interrupt signal from the controller is connected to a GPIO signal on the processor. The GPIO signal is configured via a software switch. Refer to “[AD7147 Interrupt Signal](#)” for more information.

For more information about the AD7147 capacitive touch controller, go to www.analog.com and search for AD7147.

An example program demonstrating capabilities of the touch controller is available by installing the product BSP.

Digital Accelerometer (ADXL345)

The WVGA/LCD EI3 Extender Board is equipped with an Analog Devices 3-axis accelerometer (ADXL345) with high-resolution (13-bit) measurement at up to +/- 16g. Digital output data is formatted as 16-bit twos complement and accessible through SPI or TWI.

Two interrupt signals from the ADXL345 accelerometer are connected to two GPIO signal of the processor. The GPIO signals are configured via a software switch (see “[ADXL345 Interrupt Signals](#)”). The SPI port or the TWI port is used for communications between the controller and processor; see “[ADXL345 TWI/SPI Mode Select](#)” for more information. The SPI signals are configured via software as described in “[ADXL345 SPI Chip Select](#)”. Refer to “[WVGA/LCD EI3 Extender Board Schematic](#)” on [page B-1](#) for more information.

For more information about the ADXL345 accelerometer, go to www.analog.com and search for ADX1345.

An example program demonstrating capabilities of the accelerometer is available by installing the product BSP.

Expansion Interface III

The Expansion Interface III (EI3) allows an extender board to be used across various hardware platforms that have the same expansion interface connectors.

The EI3 implemented on the WVGA/LCD EI3 Extender Board contains the PPI, SPI, TWI and GPIO ports. These signals are used for the peripherals on the extender. Signals that are not used on the extender are passed through to two connectors on the bottom side of the board (P1 and P2) and can be used for stacking another EI3 extender board. The connectors contain a majority of the processor's signals. For pinout information, go to [“WVGA/LCD EI3 Extender Board Schematic” on page B-1](#). The mechanical dimensions of the expansion connectors can be obtained by contacting [“Technical Support”](#).

For more information about extender boards, visit the Analog Devices Web site (www.analog.com).

Limits to current and interface speed must be taken into consideration when using the EI3. Current for the EI3 can be sourced from the EZ-KIT Lite/EZ-Board; therefore, the current should be limited to 200 mA for 5V and 300 mA for the 3.3V planes. If more current is required, then a separate power connector and a regulator must be designed on the daughter card. Additional circuitry can add extra loading to signals, decreasing their maximum effective speed.



Analog Devices does not support and is not responsible for the effects of additional circuitry.

Example Programs

Example programs are included with the WVGA/LCD EI3 Extender Board BSP. Example programs demonstrate various capabilities of the product. The support package is installed on top of CrossCore Embedded

Board Design Database

Studio. Once installed, the example programs can be found in the `<install_path>\WVGA_LCD_EI3_Extender_Board-RelX.X.X\WVGA_LCD_EI3` directory where *X.X.X* denotes the support package release number.

Board Design Database

A .zip file containing all of the electronic information required for the design, layout, fabrication and assembly of the product is available for download from the Analog Devices board design database at:

<http://www.analog.com/en/processors-dsp/blackfin/processors/board-design-database/resources/index.html>.

2 WVGA/LCD EI3 EXTENDER BOARD HARDWARE REFERENCE

This chapter describes the hardware design of the WVGA/LCD EI3 Extender Board.

The following topics are covered.

- [“System Architecture” on page 2-2](#)
Describes the board’s configuration and explains how the board components interface with the processor.
- [“Software-Controlled Switches \(SoftConfig\)” on page 2-3](#)
List and describe signals routed through the software-controlled switches.
- [“Connectors” on page 2-16](#)
Describes the on-board connectors.
- [“Power LED \(LED1\)” on page 2-18](#)
Describes the on-board LED.

System Architecture

A block diagram of the WVGA/LCD EI3 Extender Board is shown in Figure 2-1.

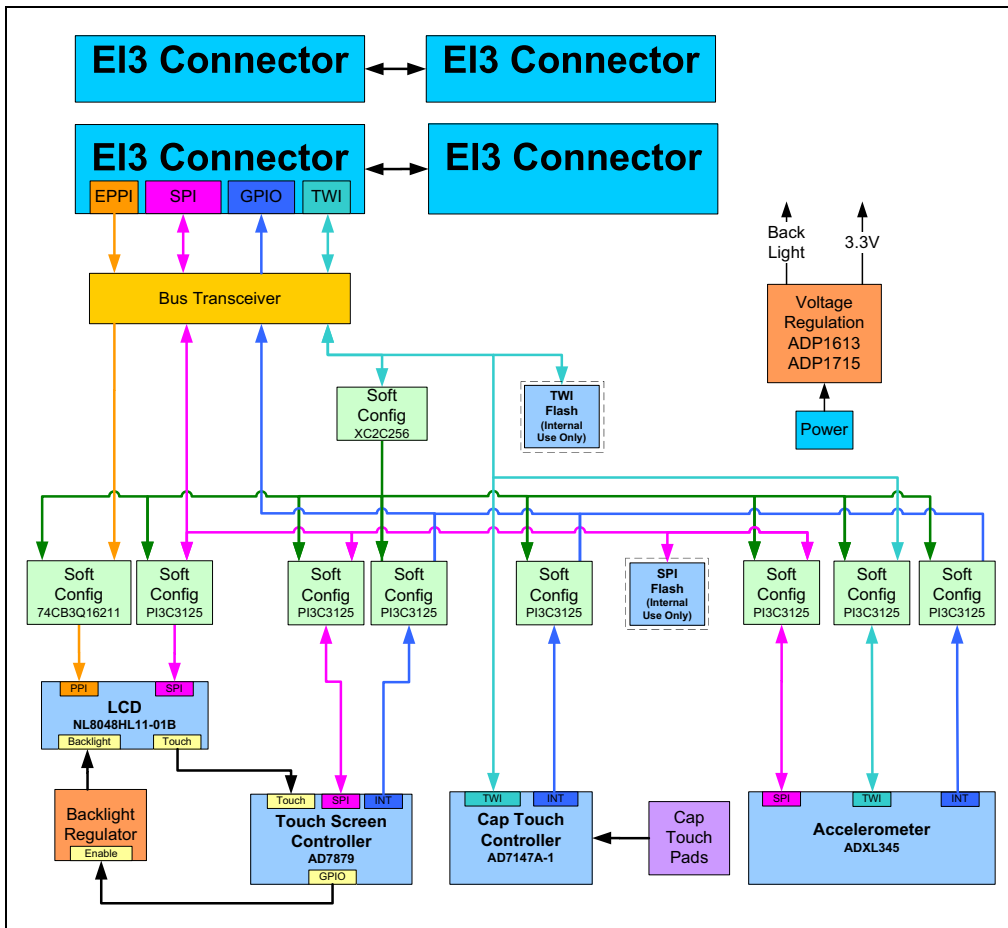



Figure 2-1. Block Diagram

Software-Controlled Switches (SoftConfig)

On the WVGA/LCD EI3 Extender Board, all of the traditional mechanical switches and jumpers have been replaced by I²C software-controlled switches. Refer to any `SoftConfig*.c` file found in the installation directory of CCES for an example of how to set up the SoftConfig features of the product through software.

The SoftConfig section of this manual serves as a reference to any user that intends to modify an existing software example. If software provided by ADI is used, there should be little need to reference this section.

 Care should be taken when changing SoftConfig settings not to create a conflict between interfaces. The same GPIO signal and SPICS should not be configured for more than one interface.

Overview of SoftConfig

In order to further clarify the use of electronic single FET switches and multi-channel bus switches, an example of each is illustrated and compared to a traditional mechanical switching solution. This is a generic example. After the generic discussion, there is a detailed explanation of the SoftConfig interface specific to the extender board.

[Figure 2-2](#) shows two individual FET switches (Pericom PI3A125CEX) with reference designators UA and UB. Net names `ENABLE_A` and `ENABLE_B` control UA and UB. In this example, the default FET switch enable settings are controlled by resistors RA and RB which pull the enable pin 1 of UA and UB to ground (low). In a real example, these enable signals are controlled by the Microchip IO expander. The default pull-down resistors connects the signals `EXAMPLE_SIGNAL_A` and `EXAMPLE_SIGNAL_B` and also connects signals `EXAMPLE_SIGNAL_C` and `EXAMPLE_SIGNAL_D`. To disconnect `EXAMPLE_SIGNAL_A` from `EXAMPLE_SIGNAL_B`, the Microchip IO expander is

Software-Controlled Switches (SoftConfig)

used to change `ENABLE_A` to a logic 1 through software that interfaces with the Microchip. The same procedure for `ENABLE_B` disconnects `EXAMPLE_SIGNAL_C` from `EXAMPLE_SIGNAL_D`.

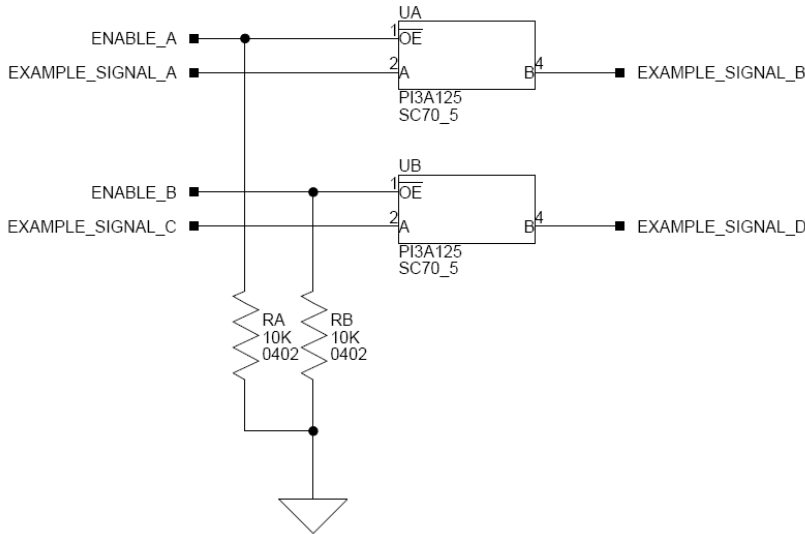

Figure 2-2. Example of Individual FET Switches

Figure 2-3 shows the equivalent circuit to Figure 2-2 but utilizes mechanical switches that are in the same package. The default is shown by black boxes located closer to the ON label of the switches. In order to disconnect these switches, physically move the switch to the OFF position.

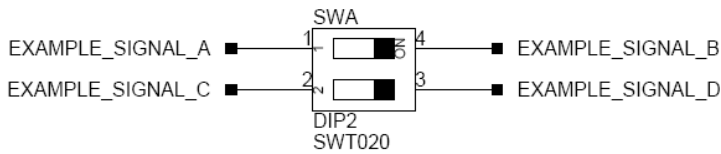

Figure 2-3. Example of Mechanical Switch Equivalent to [Figure 2-2](#)

[Figure 2-4](#) shows a bus switch example, reference designator UC (Pericom PI3LVD512ZHE), selecting between lettered functionality and numbered functionality. The signals on the left side are multiplexed signals with naming convention `letter_number`. The right side of the circuit shows the signals separated into letter and number, with the number on the lower group (eg. 0B1) and the letter on the upper group (eg. 0B2). The default setting is controlled by the signal `CONTROL_LETTER_NUMBER` which is pulled low. This selects the number signals on the right to be connected to the multiplexed signals on the left by default. In this example, the Microchip IO expander is not shown but controls the signal `CONTROL_LETTER_NUMBER` and allows the user to change the selection through software.

[Figure 2-5](#) shows the equivalent circuit to [Figure 2-4](#) but utilizes mechanical switches. Notice the default for reference designators SWC and SWD is illustrated by black boxes located closer to the ON label of the switches to enable the number signals by default. Note the default setting for reference designators SWE and SWF is OFF. In order to connect the letters instead of the numbers, the user physically changes all switches on SWC and SWD to the OFF position and all switches on SWE and SWF to the ON position.

Software-Controlled Switches (SoftConfig)

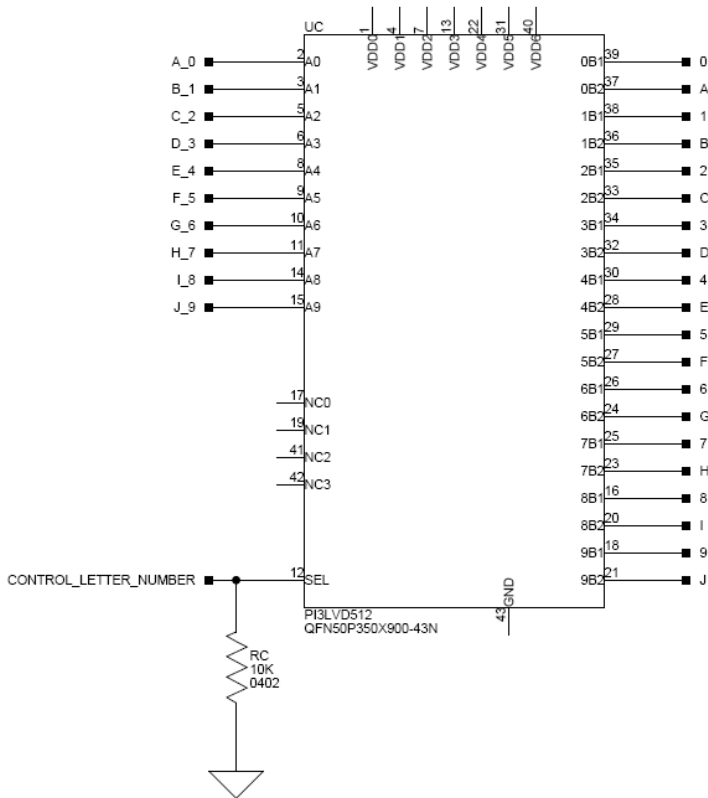

Figure 2-4. Example of Bus Switch

WVGA/LCD EI3 Extender Board Hardware Reference

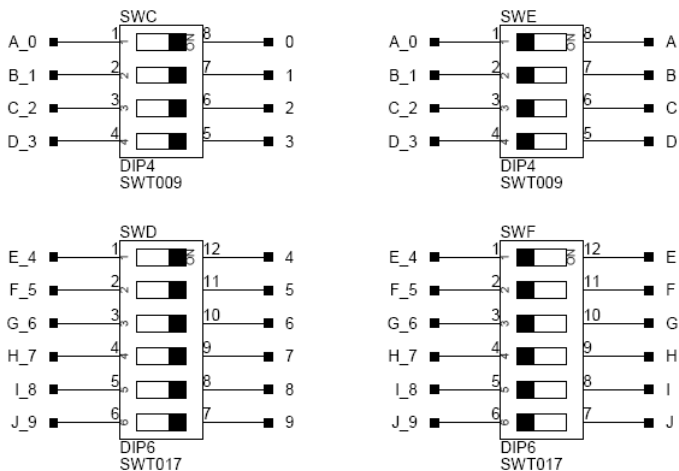

Figure 2-5. Example of Mechanical Switch Equivalent to [Figure 2-4](#)

Programming SoftConfig on the WVGA/LCD EI3 Extender Board

On the WVGA/LCD EI3 Extender Board, a single Xilinx XC2C256 complex programmable logic device (CPLD) controls individual and

Software-Controlled Switches (SoftConfig)

electronic bus switches via TWI. The device has the following programming characteristics:

- There are seven programmable GPIO registers.

GPIO Register	Register Address
GPIOA	0x03
GPIOB	0x05
GPIOC	0x07
GIPOD	0x09
GPIOE	0x0b
GPIOF	0x0d
GPIOG	0x0f

- Each GPIO register controls eight signals (software switches).
- By default, the GPIO signals function as input signals; therefore, all electronic switches are in the OFF state.

The signals must be programmed as output signals to override their default values. The following table shows the register addresses and values that must be written to them to program the signals as output signals.

IODIR Register	IODIR Register Address	Value to be Written to Program Signals as Outputs
IODIRA	0x02	0
IODIRB	0x04	0
IODIRC	0x06	0
IODIRD	0x08	0
IODIRE	0x0a	0

WVGA/LCD EI3 Extender Board Hardware Reference

IODIR Register	IODIR Register Address	Value to be Written to Program Signals as Outputs
IODIRF	0x0c	0
IODIRG	0x0e	0

Each of the examples in the BSP includes source files that program the soft switches, even if the default settings are being used. The README for each example identifies only the signals that are being changed from their default values. The code that programs the soft switches is located in the `SoftConfig_LCD.c` file in each example.

Page 2 of [“WVGA/LCD EI3 Extender Board Schematic” on page B-1](#) shows how the GPIO expander is connected to the board’s ICs.

U14-16 are 24-bit bus switches. The switches select how the LCD module is connected to the processor. You can select a 16-, 18-, or 24-bit interface.

U31-41 are 2-port bus switches. The switches select the GPIO signals to be used as interrupts and SPICS signals to connect to various IC on the extender.

The U44-45 switches select the interface to communicate with the accelerometer: SPI or TWI.

[Table 2-1](#) through [Table 2-6](#) show the output signals of the GPIO expander (U10) with a TWI address of 0100 111X, where X represents the read or write bit. The signals that control an individual FET have an entry

Software-Controlled Switches (SoftConfig)

under the **FET** column. The **Component Connected** column shows the board IC that is connected if the FET is enabled.

Table 2-1. Output Signals of GPIO Expander (U10 Port A)

Bit	Signal Name	Description	FET	Component Connected	Default
0	~TOUCH_SCREEN_IRQ_GPI00	Touch screen interrupt	U41	U19	OFF
1	~TOUCH_SCREEN_IRQ_GPI01	Touch screen interrupt	U41	U19	OFF
2	~TOUCH_SCREEN_IRQ_GPI02	Touch screen interrupt	U41	U19	OFF
3	~TOUCH_SCREEN_IRQ_GPI03	Touch screen interrupt	U41	U19	OFF
4	~TOUCH_SCREEN_IRQ_GPI04	Touch screen interrupt	U40	U19	OFF
5	~TOUCH_SCREEN_IRQ_GPI05	Touch screen interrupt	U40	U19	OFF
6	~TOUCH_SCREEN_IRQ_GPI06	Touch screen interrupt	U40	U19	OFF
7	~TOUCH_SCREEN_IRQ_GPI07	Touch screen interrupt	U40	U19	OFF

Table 2-2. Output Signals of GPIO Expander (U10 Port B)

Bit	Signal Name	Description	FET	Component Connected	Default
0	~CAP_TOUCH_INT_GPI00	Cap touch interrupt	U38	U7	OFF
1	~CAP_TOUCH_INT_GPI01	Cap touch interrupt	U38	U7	OFF
2	~CAP_TOUCH_INT_GPI02	Cap touch interrupt	U38	U7	OFF
3	~CAP_TOUCH_INT_GPI03	Cap touch interrupt	U38	U7	OFF
4	~CAP_TOUCH_INT_GPI04	Cap touch interrupt	U37	U7	OFF
5	~CAP_TOUCH_INT_GPI05	Cap touch interrupt	U37	U7	OFF
6	~CAP_TOUCH_INT_GPI06	Cap touch interrupt	U37	U7	OFF
7	~CAP_TOUCH_INT_GPI07	Cap touch interrupt	U37	U7	OFF

WVGA/LCD EI3 Extender Board Hardware Reference

Table 2-3. Output Signals of GPIO Expander (U10 Port C)

Bit	Signal Name	Description	FET	Component Connected	Default
0	~ADXL_INT1_GPI00	Accelerometer interrupt 1	U33	U27	OFF
1	~ADXL_INT1_GPI01	Accelerometer interrupt 1	U33	U27	OFF
2	~ADXL_INT1_GPI02	Accelerometer interrupt 1	U33	U27	OFF
3	~ADXL_INT1_GPI03	Accelerometer interrupt 1	U33	U27	OFF
4	~ADXL_INT1_GPI04	Accelerometer interrupt 1	U34	U27	OFF
5	~ADXL_INT1_GPI05	Accelerometer interrupt 1	U34	U27	OFF
6	~ADXL_INT1_GPI06	Accelerometer interrupt 1	U34	U27	OFF
7	~ADXL_INT1_GPI07	Accelerometer interrupt 1	U34	U27	OFF

Table 2-4. Output Signals of GPIO Expander (U10 Port D)

Bit	Signal Name	Description	FET	Component Connected	Default
0	~ADXL_INT1_GPI00	Accelerometer interrupt 2	U35	U27	OFF
1	~ADXL_INT1_GPI01	Accelerometer interrupt 2	U35	U27	OFF
2	~ADXL_INT1_GPI02	Accelerometer interrupt 2	U35	U27	OFF
3	~ADXL_INT1_GPI03	Accelerometer interrupt 2	U35	U27	OFF
4	~ADXL_INT1_GPI04	Accelerometer interrupt 2	U36	U27	OFF
5	~ADXL_INT1_GPI05	Accelerometer interrupt 2	U36	U27	OFF
6	~ADXL_INT1_GPI06	Accelerometer interrupt 2	U36	U27	OFF
7	~ADXL_INT1_GPI07	Accelerometer interrupt 2	U36	U27	OFF

Software-Controlled Switches (SoffConfig)

Table 2-5. Output Signals of GPIO Expander (U10 Port E)

Bit	Signal Name	Description	FET	Component Connected	Default
0	~TOUCH_SCREEN_SPICS_SPICSA	Touch screen SPI chip select	U39	U19	OFF
1	~TOUCH_SCREEN_SPICS_SPICSB	Touch screen SPI chip select	U39	U19	OFF
2	~TOUCH_SCREEN_SPICS_SPICSC	Touch screen SPI chip select	U39	U19	OFF
3	~LCD_SPICS_SPICSA	LCD SPI chip select	U31	LCD	OFF
4	~LCD_SPICS_SPICSB	LCD SPI chip select	U31	LCD	OFF
5	~LCD_SPICS_SPICSC	LCD SPI chip select	U31	LCD	OFF
6	Not Used				
7	PPICKL_DIR	Selects if the PPI clock is an input or output on the extender	U1	U8	Input

Table 2-6. Output Signals of GPIO Expander (U10 Port F)

Bit	Signal Name	Description	FET	Component Connected	Default
0	~ADXL_SPICS_SPICSA	Accelerometer SPI chip select	U32	U27	OFF
1	~ADXL_SPICS_SPICSB	Accelerometer SPI chip select	U32	U27	OFF
2	~ADXL_SPICS_SPICSC	Accelerometer SPI chip select	U32	U27	OFF
3	~ADXL_SPI_MODE	Enable SPI on accelerometer	U45	U27	OFF
4	ADXL_TWI_MODE	Enable TWI on accelerometer	U44	U27	OFF
5	~24_BIT_LCD_MODE	24-bit LCD mode	U16	LCD	OFF
6	~18_BIT_LCD_MODE	18-bit LCD mode	U15	LCD	OFF
7	~16_BIT_LCD_MODE	16-bit LCD mode	U14	LCD	OFF

LCD SPI Chip Select

The LCD SPICS switch connects the chip select pin of the serial peripheral interconnect interface (SPI) of the LCD to one of three SPI select pins of the processor. U10 ports GPE3, GPE4, and GPE5 select the connection to the appropriate SPICS signal via the U31 bus switch.

PPICLK_DIR Select

The PPICLK_DIR select switch determines whether the LCD clock is generated by an on-board oscillator or by the processor. By driving the PPICLK_DIR signal (U10 port GPE7) high, the on-board oscillator is enabled and driven to the LCD and processor via the U1 dual-supply bus transceiver. By driving the PPICLK_DIR signal low, the on-board oscillator is disabled, and the clock from the processor is driven to the LCD via the U1 dual-supply bus transceiver.

LCD Mode Select

The LCD mode select switch determines whether the interface to the processor's PPI is 16, 18, or 24 bits. In 16-bit mode, RGB565 is supported. In 18-bit mode, RGB666 is supported. In 24-bit mode, RGB888 is supported. The LCD mode is selected by driving low the 24_BIT_LCD_MODE (U10 port GPF5), 18_BIT_LCD_MODE (U10 port GPF6), or 16_BIT_LCD_MODE (U10 port GPF7) signal. Driving one of these signals low enables the appropriate bus switch (U14-16).

AD7879 PENIRQ Signal

The AD7879 PENIRQ switch connects the interrupt signal of the AD7879 touch screen controller to one of eight GPIO pins of the processor. U10 ports GPA0-7 select the connection to the appropriate GPIO signal via the U40 and U41 bus switches.

AD7879 SPI Chip Select

The AD7879 SPICS connects the chip select pin of the SPI of the AD7879 touch screen controller to one of three SPI select pins of the processor. U10 ports GPE0, GPE1, and GPE2 are used to select the connection to the appropriate SPICS signal via the U39 bus switch.

AD7147 Interrupt Signal

The AD7147 INT signal connects the interrupt signal of the AD7147 touch controller to one of eight GPIO pins of the processor. U10 ports GPB0-7 select the connection to the appropriate GPIO signal via the U37 and U38 bus switches.

ADXL345 Interrupt Signals

The ADXL345 INT1 and INT2 connect the interrupt signals of the ADXL345 accelerometer to one of eight GPIO pins of the processor. U10 ports GPC0-7 and GPD0-7 select the connection to the appropriate GPIO signal via the U33-36 bus switch.

ADXL345 TWI/SPI Mode Select

The ADXL345 TWI/SPI mode select pin configures the interface connected to the ADXL345 accelerometer. When the accelerometer's interface is configured for SPI, the appropriate SPICS must also be configured.

To configure the ADXL345 accelerometer for operating in SPI mode, the `~ADXL345_SPI_MODE` signal (U10 port GPF3) is driven low to enable the U45 bus switch.

To configure the ADXL345 accelerometer for operating in TWI mode, the `~ADXL345_TWI_MODE` signal (U10 port GPF4) is driven high to enable the U44 TWI switch.

ADXL345 SPI Chip Select

The ADXL345 `SPICS` pin connects the chip select pin of the SPI of the ADXL345 accelerometer to one of three SPI select pins of the processor. `U10` ports `GPF0`, `GPF1`, and `GPF2` select the connection to the appropriate `SPICS` signal via the `U32` bus switch.

Connectors

This section describes connector functionality and provides information about mating connectors. The connector locations are shown in [Figure 2-6](#).

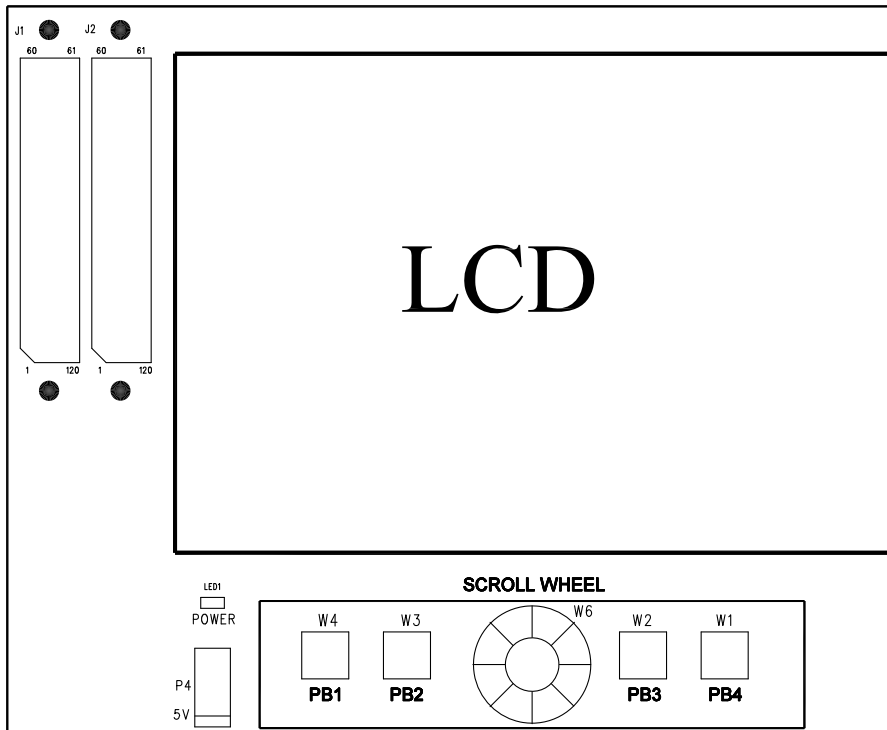

Figure 2-6. Connector Locations

Expansion Interface III (EI3) Connectors (J1–2)

Two board-to-board connectors (J1 and J2) provide signals from the SPI, TWI, UART, SPORT, and GPIO interfaces of the processor. The connectors are located on the top side of the board. For more information, see [“Expansion Interface III” on page 1-7](#).

Part Description	Manufacturer	Part Number
120-pin, 0.6 mm	HIROSE	FX8-120S-SV(21)
Mating Connector		
120-pin, 0.6 mm	HIROSE	FX8-120P-SV1(91)

Expansion Interface III (EI3) Connectors (P1–2)

Two board-to-board connectors (P1 and P2) provide signals from the SPI, TWI, UART, SPORT, and GPIO interfaces of the processor. The connectors are located on the bottom side of the board and used when stacking another board under the extender board. For more information, see [“Expansion Interface III” on page 1-7](#).

Part Description	Manufacturer	Part Number
120-pin, 0.6 mm	HIROSE	FX8-120P-SV1(91)
Mating Connector		
120-pin, 0.6 mm	HIROSE	FX8-120S-SV(21)

Power Connector (P4)

By design, the extender board derives its power from the EZ-KIT Lite/EZ-Board. If the EZ-KIT Lite/EZ-Board is not able to supply enough power to the extender, an external power supply can be connected to the extender via P4.

Power LED (LED1)

Part Description	Manufacturer	Part Number
0.65 mm power jack	CUI	045-0883R
Mating Connector		
5.0VDC@3.6A power supply	GLOBETEK	GS-1750(R)

LCD Connector (P5)

The LCD connector (P5) is used to connect the LCD to the extender board. The backlight power pins, four resistive touch pins, LCD SPI interface, data, sync, and clock pins of the LCD connect to P5 via a single flex cable.

Power LED (LED1)

When the power LED (LED1) lights solid (green), it indicates that the power is being supplied to the board properly.

A WVGA/LCD EI3 EXTENDER BOARD BILL OF MATERIALS

The bill of materials corresponds to “WVGA/LCD EI3 Extender Board Schematic” on page B-1.

Ref.	Qty.	Description	Reference Designator	Manufacturer	Part Number
1	1	25MHZ OSC003	U8	EPSON	SG-8002CA MP
2	2	SN74AVCA16424 5 TVSOP48	U5-U6	TI	74AVCA164245VRE4
3	1	SN74LVC1G08 SOT23-5	U18	TI	SN74LVC1G08DBVR
4	3	SN74CB3Q16211 TSSOP56	U14-U16	DIGI-KEY	296-17629-1-ND
5	12	PI3C3125 TSSOP14	U31-U41,U45	PERICOM	PI3C3125
6	1	PCA9525 TSSOP8	U44	DIGI KEY	568-6665-2-ND
7	1	SN74AVC2T245 QFN10	U1	DIGIKEY	296-23684-1-ND
8	1	XC2C256 VQ100	U10	XILINX	XC2C256-7VQG100C
9	1	SN74CB3Q3125 TSSOP14	U11	DIGI-KEY	296-16804-1-ND
10	1	AD7879 LFCSP_VQ16	U19	ANALOG DEVICES	AD7879ACPZ-500R7
11	1	AD7147-1 LFCSP_VQ24	U7	ANALOG DEVICES	AD7147ACPZ-1500RL7
12	1	ADP120-AUJZ18 R7 TSOT5	VR3	ANALOG DEVICES	ADP120-AUJZ18R7

Ref.	Qty.	Description	Reference Designator	Manufacturer	Part Number
13	1	ADP1715 MSOP8	VR2	ANALOG DEVICES	ADP1715ARMZ-3.3-R7
14	1	ADP1613 MSOP8	VR1	ANALOG DEVICES	ADP1613ARMZ-R7
15	1	ADXL345BCCZ LGA14	U27	ANALOG DEVICES	ADXL345BCCZ
16	1	ADP121-AUJZ30 TSOT5	VR4	ANALOG DEVICES	ADP121-AUJZ30R7
17	1	PWR .65MM CON027	P4	DIGI-KEY	CP1-022PJCT-ND
18	1	1A RESETABLE 1206	F1	RAYCHEM	NANOSMDC110F-2
19	2	.6MM 120PIN HIROSE_FX8-120 P-SV1(91)	P1-P2	HIROSE	FX8-120P-SV1(91)
20	2	.6MM 120PIN HIROSE_FX8-120 S-SV(21)	J1-J2	HIROSE	FX8-120S-SV(21)
21	1	FPC 51PIN HIROSE_FH23-5 1S-0_3SHW(06)	P5	HIROSE	FH23-51S-0.3SHW(06)
22	1	0.1UF 50V 10% 0805	C27	AVX	08055C104KAT
23	1	600 100MHZ 200MA 0603	FER1	DIGI-KEY	490-1014-2-ND
24	7	10K 31MW 5% RNET8	RN1-RN7	CTS	746X101103JP
25	2	1UF 10V 10% 0805	C28-C29	AVX	0805ZC105KAT2A
26	2	10UF 6.3V 10% 0805	C56,C68	AVX	08056D106KAT2A

WVGA/LCD EI3 Extender Board Bill Of Materials

Ref.	Qty.	Description	Reference Designator	Manufacturer	Part Number
27	2	0.1UF 10V 10% 0402	C58-C59	AVX	0402ZD104KAT2A
28	48	0.1UF 10V 10% 0402	C1-C8,C13-C22, C25-C26,C33, C36,C39-C53, C55,C57,C60- C67,C70	AVX	0402ZD104KAT2A
29	14	10K 1/16W 5% 0402	R2,R6,R9-R10, R16,R23-R25, R29,R32,R37, R52-R54	VISHAY	CRCW040210K0FKE
30	20	10K 1/16W 5% 0402	R1,R4,R19-R22, R26-R28,R30- R31,R43-R51	VISHAY	CRCW040210K0FKE
31	6	0 1/16W 5% 0402	R34-R36,R38- R40	PANASONIC	ERJ-2GE0R00X
32	1	0 1/16W 5% 0402	R5	PANASONIC	ERJ-2GE0R00X
33	1	33 1/16W 5% 0402	R18	VISHAY	CRCW040233R0JNE
34	1	1A SK12 DO-214AA	D10	DIODES INC	B120B-13-F
35	2	0.1UF 16V 10% 0603	C30,C32	AVX	0603YC104KAT2A
36	1	4.7UF 25V 20% 0805	C23	AVX	0805ZD475KAT2A
37	1	10K 1/10W 5% 0603	R14	VISHAY	CRCW060310K0JNE
38	3	10UF 10V 10% 0805	C24,C34,C54	PANASONIC	ECJ-2FB1A106K
39	2	2.0K 1/16W 1% 0603	R11,R15	PANASONIC	ERJ-3EKF2001V

Ref.	Qty.	Description	Reference Designator	Manufacturer	Part Number
40	2	2.0K 1/16W 1% 0603	R12,R17	PANASONIC	ERJ-3EKF2001V
41	2	1.1K 1/16W 1% 0402	R55-R56	PANASONIC	ERJ-2RKF1101X
42	2	1.1K 1/16W 1% 0402	R57-R58	PANASONIC	ERJ-2RKF1101X
43	1	430 1/16W 1% 0402	R33	DIGI-KEY	311-430LRCT-ND
44	1	47.0K 1/16W 1% 0402	R8	ROHM	MCR01MZPF4702
45	1	1UF 50V 10% 0603	C31	DIGI-KEY	587-1257-2-ND
46	1	15uH 20% IND015	L1	COILCRAFT	MSS4020-153ML
47	3	.5A B0540W SOD-123	D7-D9	DIODES INC	B0540W-7-F
48	1	.5A BZT52C33S SOD-323	D11	DIODES INC	BZT52C33S-7-F
49	6	2.2UF 25V 10% 0805	C9,C11-C12, C35,C37,C69	DIGI KEY	445-6860-2-ND
50	3	1A MBR130LSFT1G SOD-123FL	D3-D5	ON SEMI	MBR130LSFT1G
51	1	30A GSOT03 SOT23-3	D6	VISHAY	GSOT03-GS08
52	1	GREEN 0603	LED1	DIGI KEY	475-1409-2-ND
53	1	1UF 50V 10% 0805	C38	DIGI KEY	490-4736-2-ND

WVGA/LCD EI3 Extender Board Bill Of Materials

Ref.	Qty.	Description	Reference Designator	Manufacturer	Part Number
54	1	100K 1/4W 20% TRIM_PVG3A104 C01R00	R3	DIGIKEY	490-2645-1-ND
55	1	43.2 1/10W 1% 0402	R13	PANASONIC	ERJ-2RKF43R2X

A

B

C

D

1

1

2

2

3

3

4

4

WVGA/LCD EI3 Extender Board SCHEMATIC

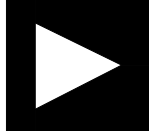
		ANALOG DEVICES		20 Cotton Road Nashua, NH 03063 PH: 1-800-ANALOGD
Title		WVGA/LCD EI3 Extender Board Title Sheet		
Size C	Board No.	A0254-2010		Rev 1.0
Date	2/13/12	Sheet	1	of 8

A

B

C

D

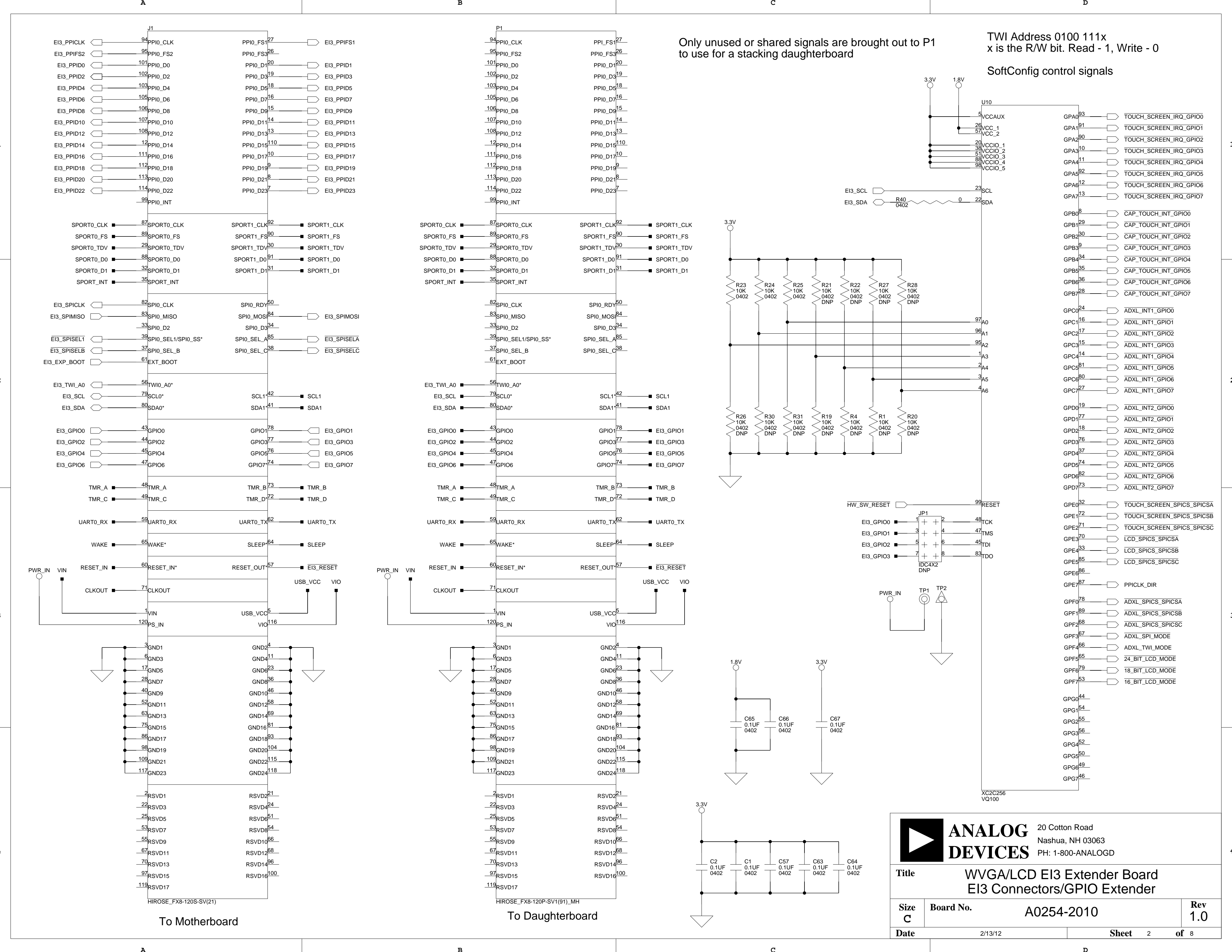

Only unused or shared signals are brought out to P1 to use for a stacking daughterboard

TWI Address 0100 111x
 x is the R/W bit. Read - 1, Write - 0

SoftConfig control signals

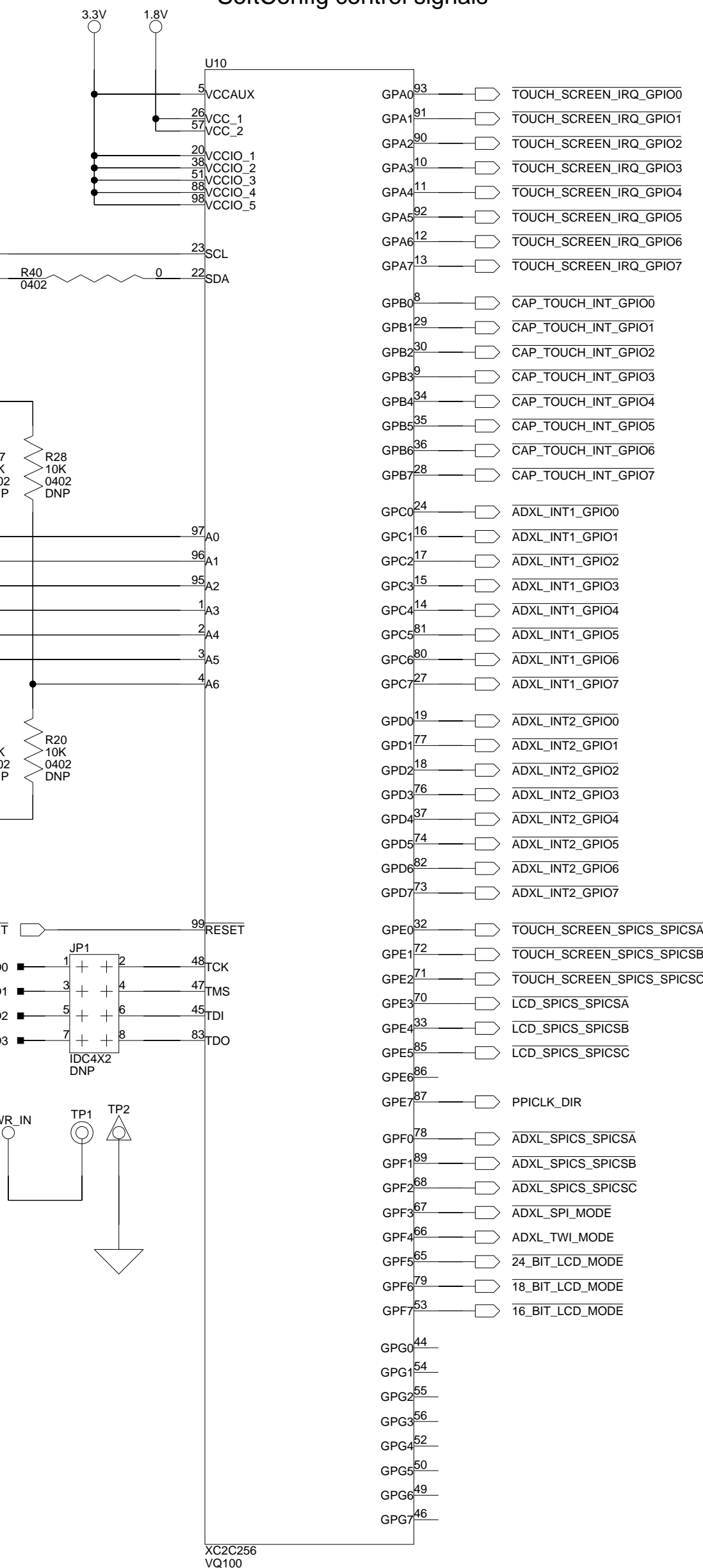

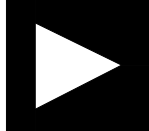
 ANALOG DEVICES		20 Cotton Road Nashua, NH 03063 PH: 1-800-ANALOGD	
Title WVGA/LCD E13 Extender Board E13 Connectors/GPIO Extender			
Size C	Board No.	A0254-2010	
Date	2/13/12	Sheet	2 of 8
		Rev 1.0	

The signals are passed from J2 to P2

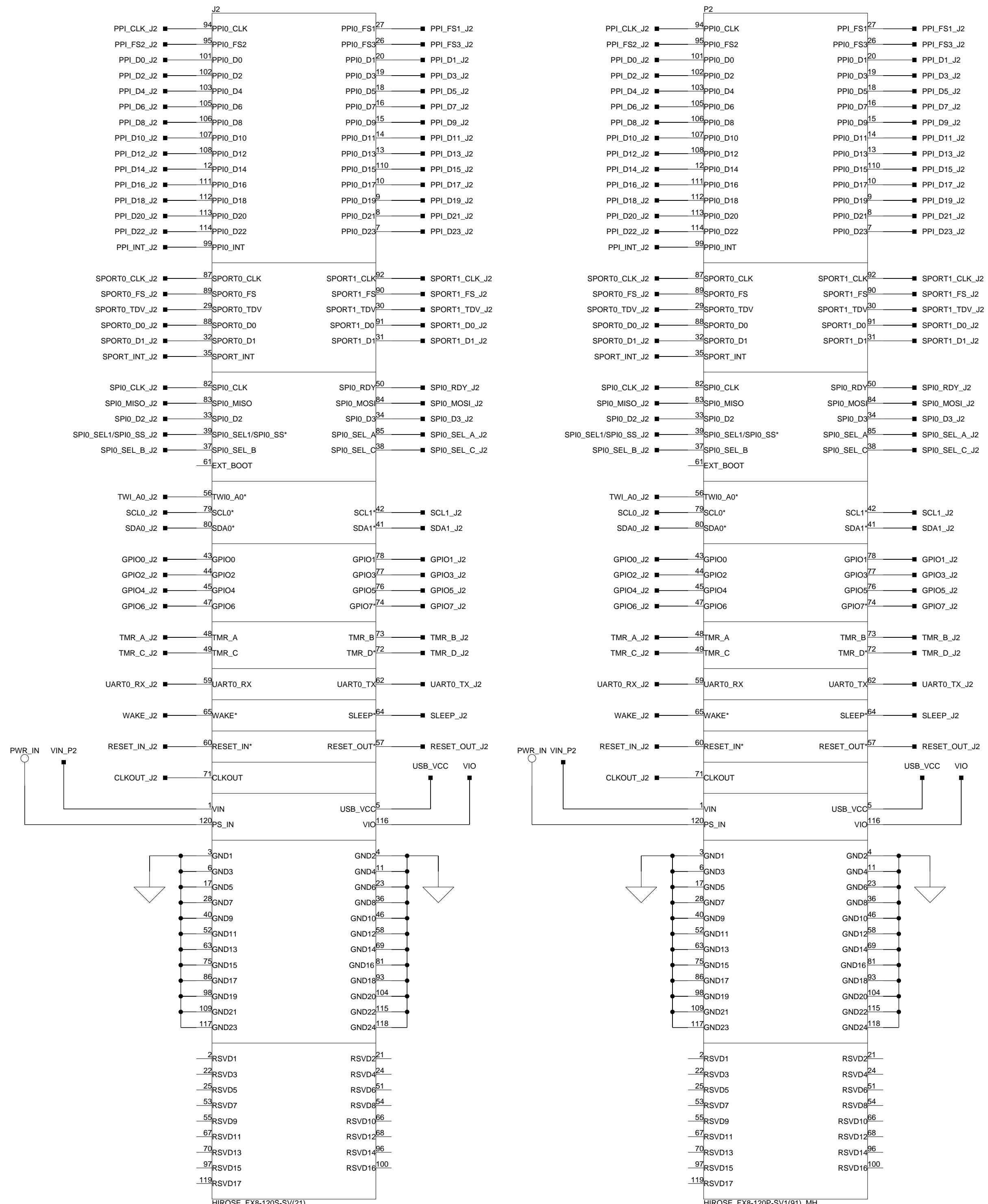

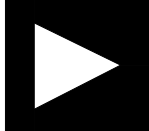
 ANALOG DEVICES		20 Cotton Road Nashua, NH 03063 PH: 1-800-ANALOGD	
		Title WVGA/LCD EI3 Extender Board EI3 Unused Connectors	
Size C	Board No.	A0254-2010	
Date	2/13/12	Sheet	3 of 8
		Rev	1.0

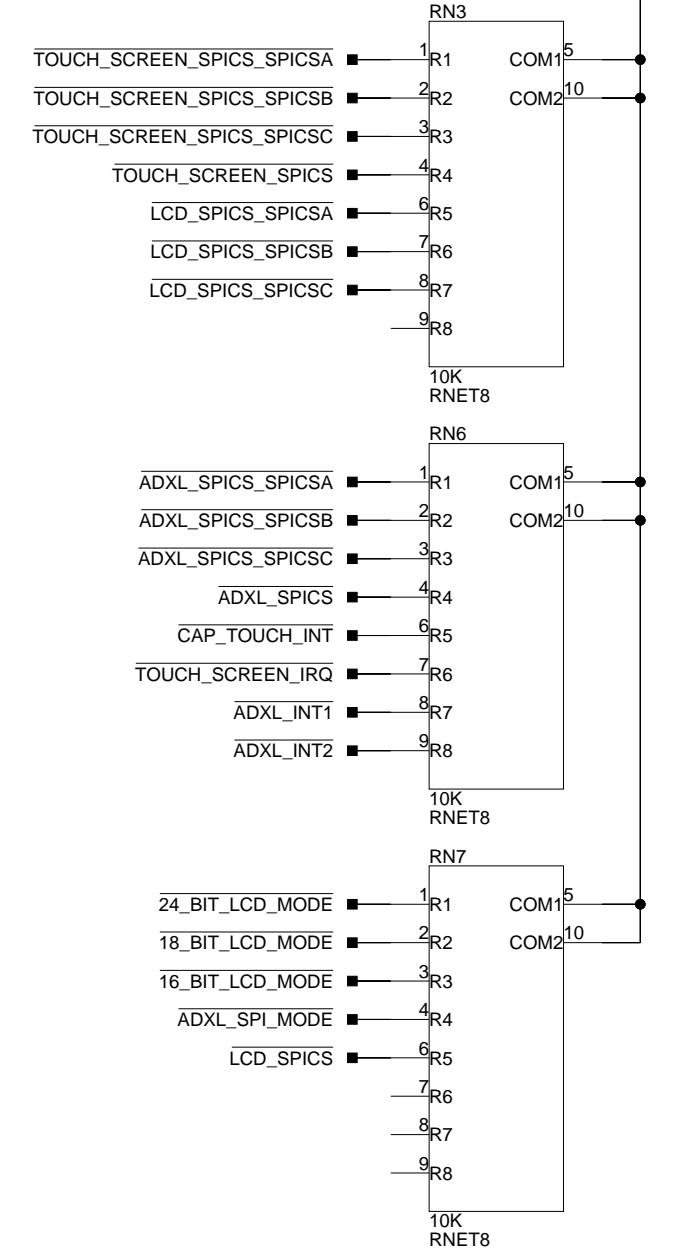
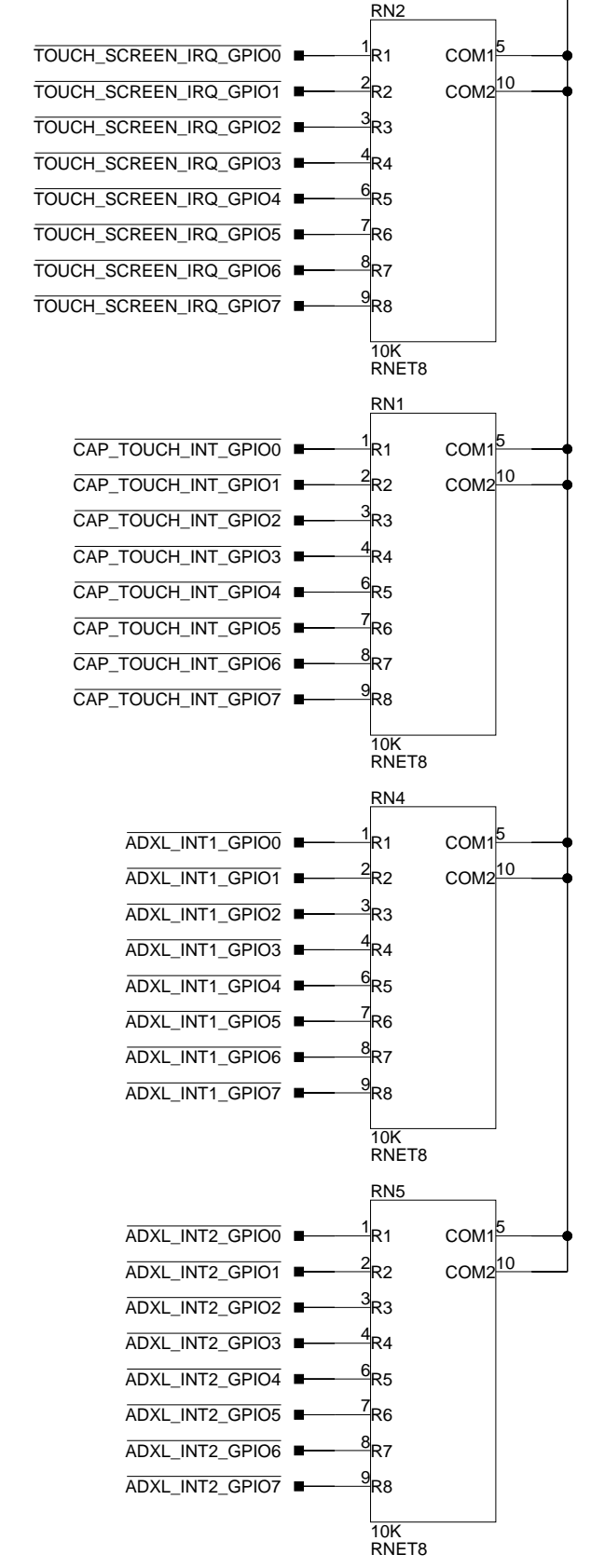
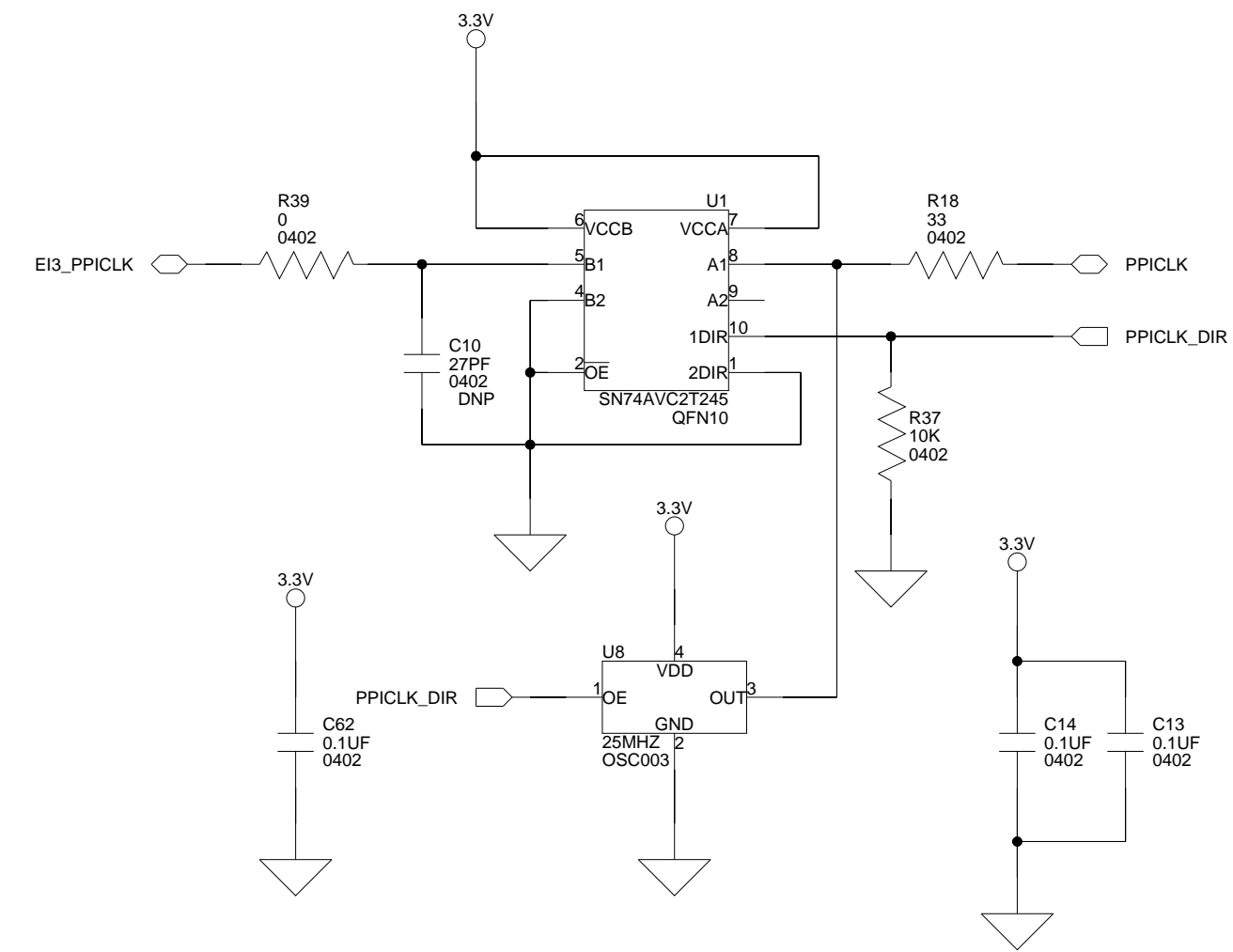
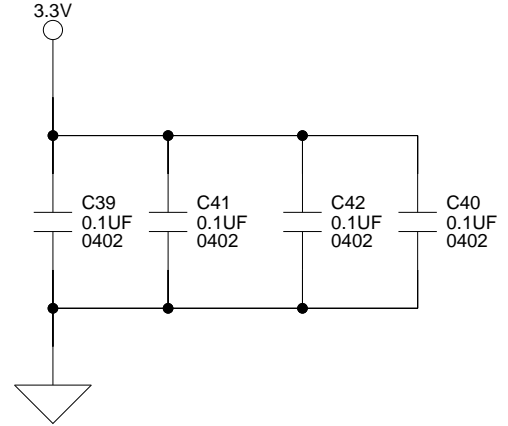
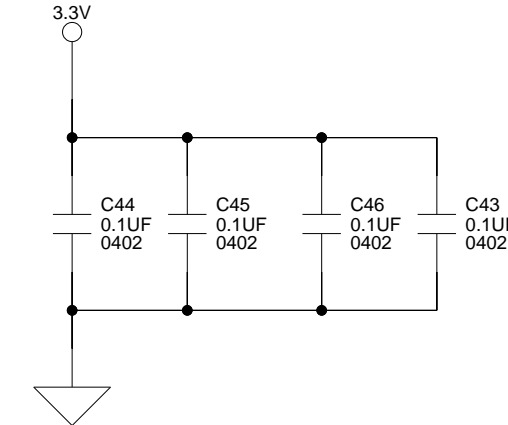
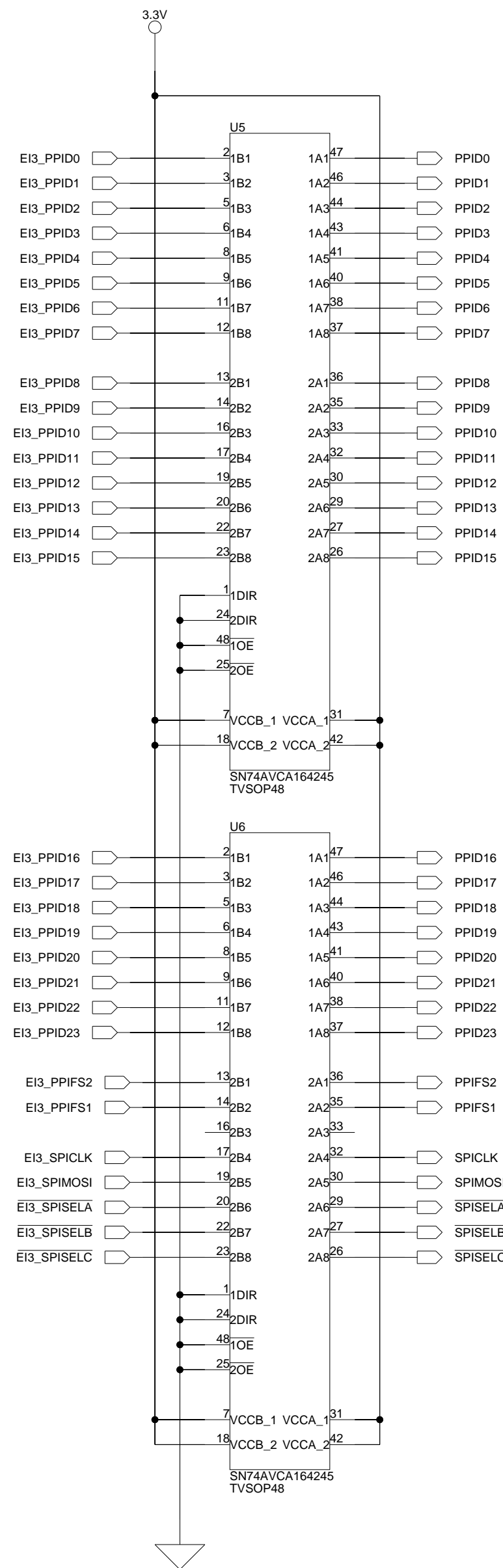

		20 Cotton Road Nashua, NH 03063 PH: 1-800-ANALOGD	
		Title WVGA/LCD EI3 Extender Board Buffers/Clock/Pull-Ups	
Size C	Board No. A0254-2010	Rev 1.0	
Date 2/13/12	Sheet 4 of 8		

A

B

C

D

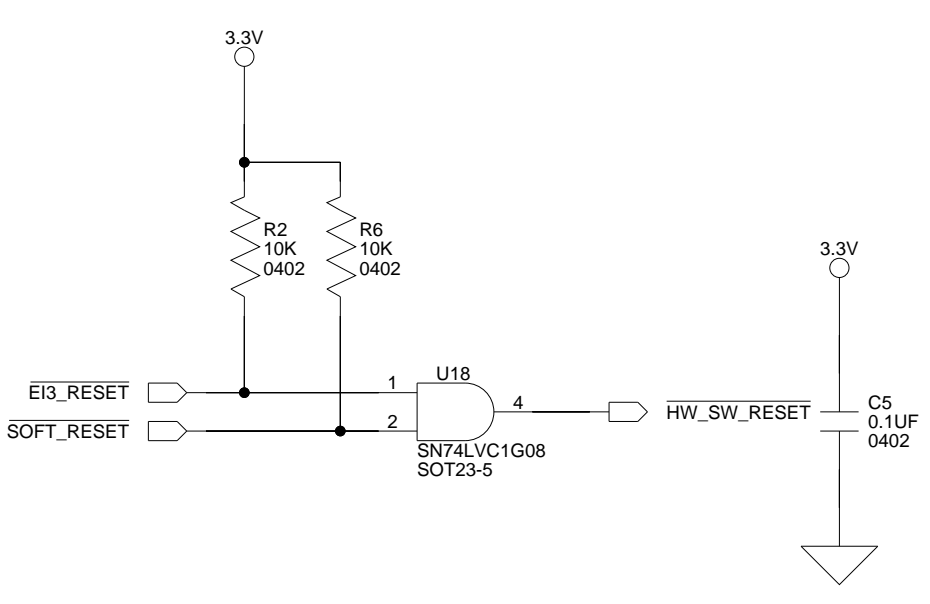
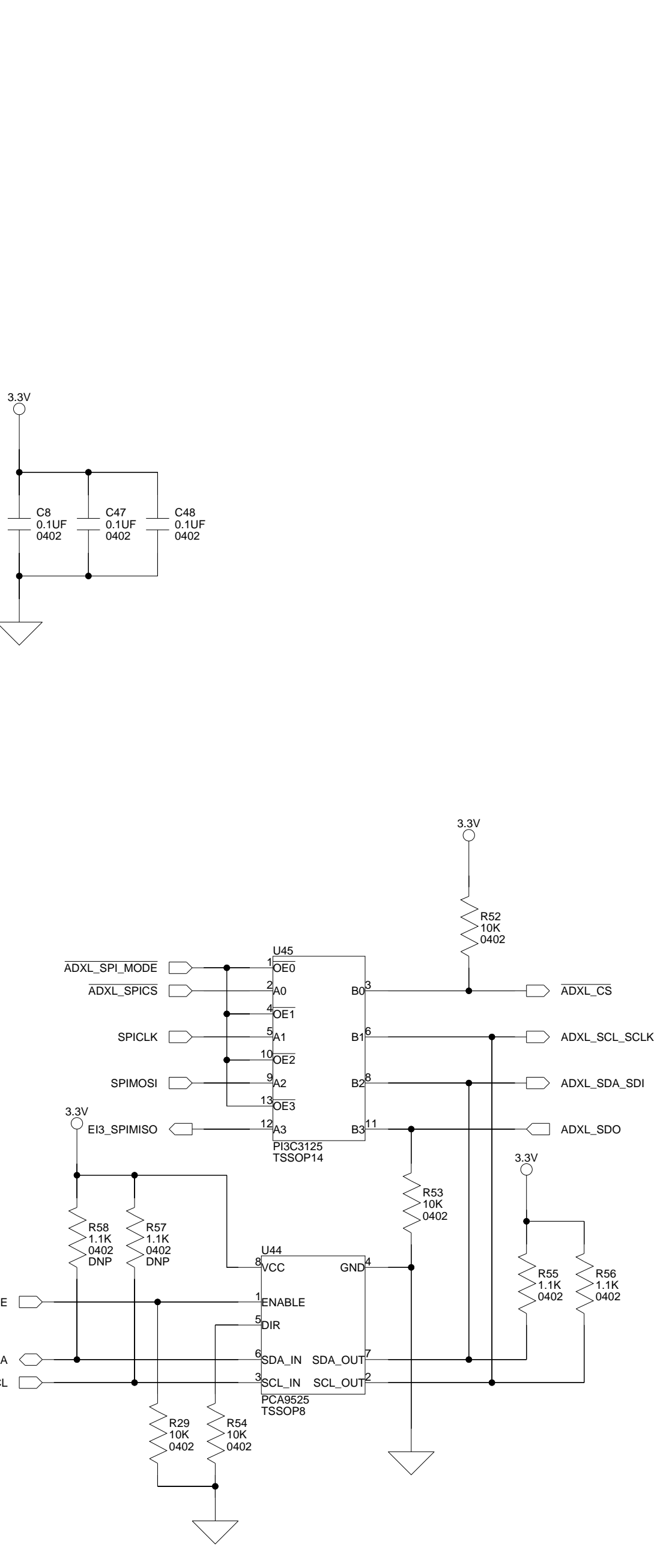
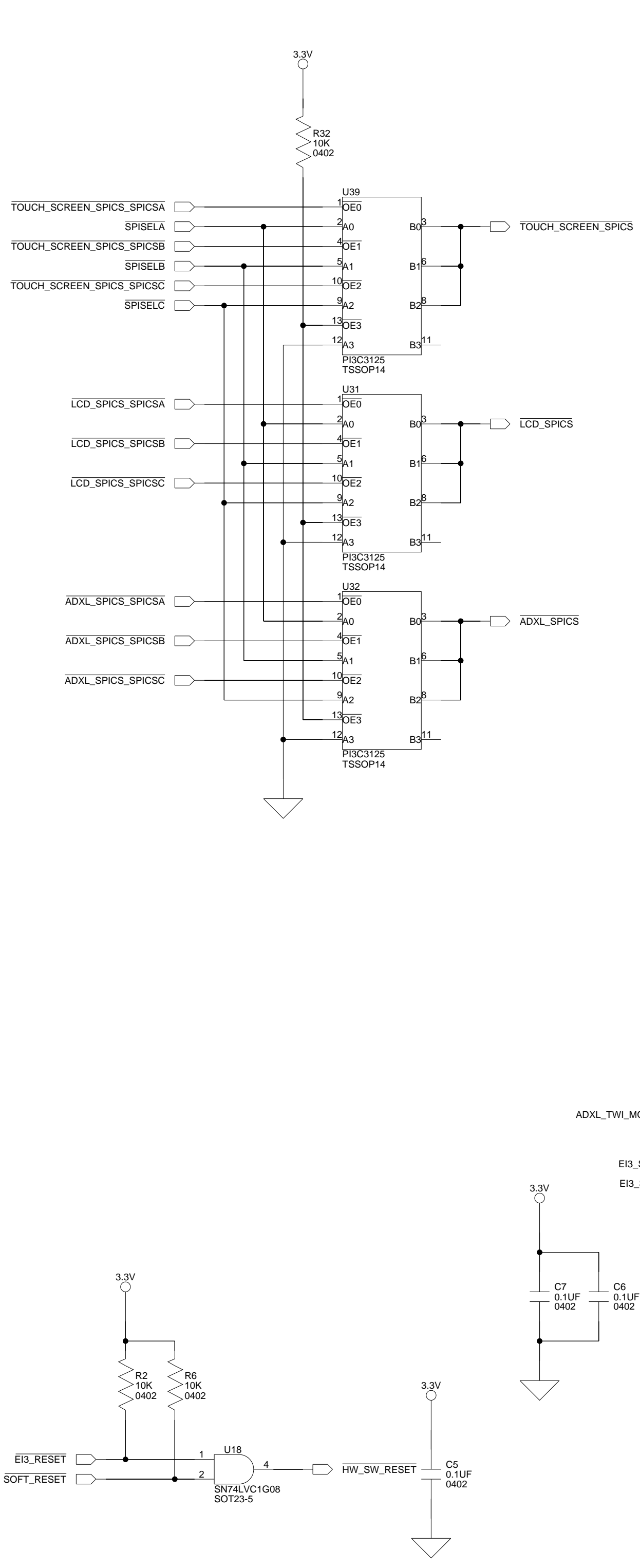
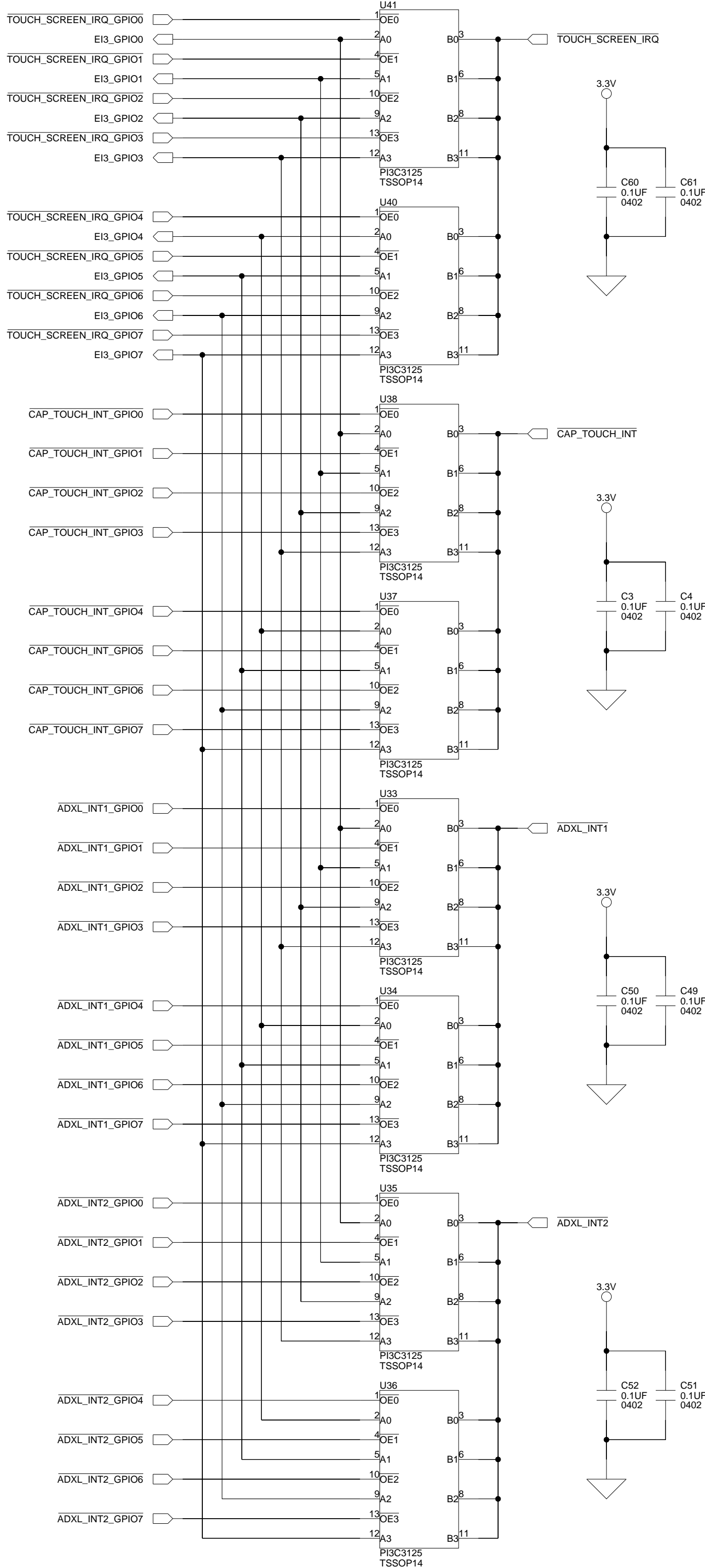

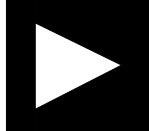
 ANALOG DEVICES		20 Cotton Road Nashua, NH 03063 PH: 1-800-ANALOGD	
		Title WVGA/LCD EI3 Extender Board SoftConfig and Reset	
Size C	Board No. A0254-2010	Rev 1.0	
Date 2/13/12	Sheet 5 of 8		

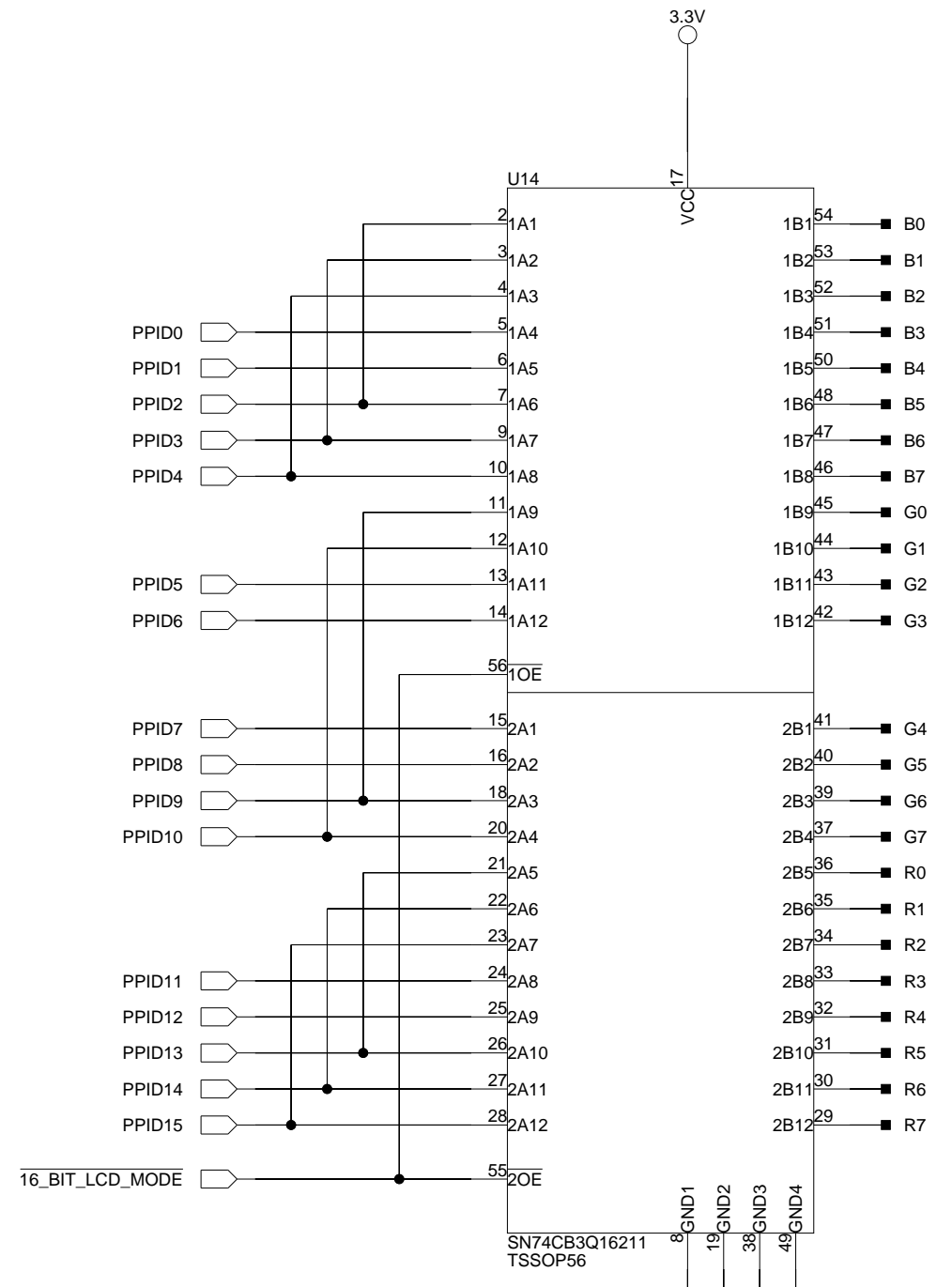

16-Bit Mode

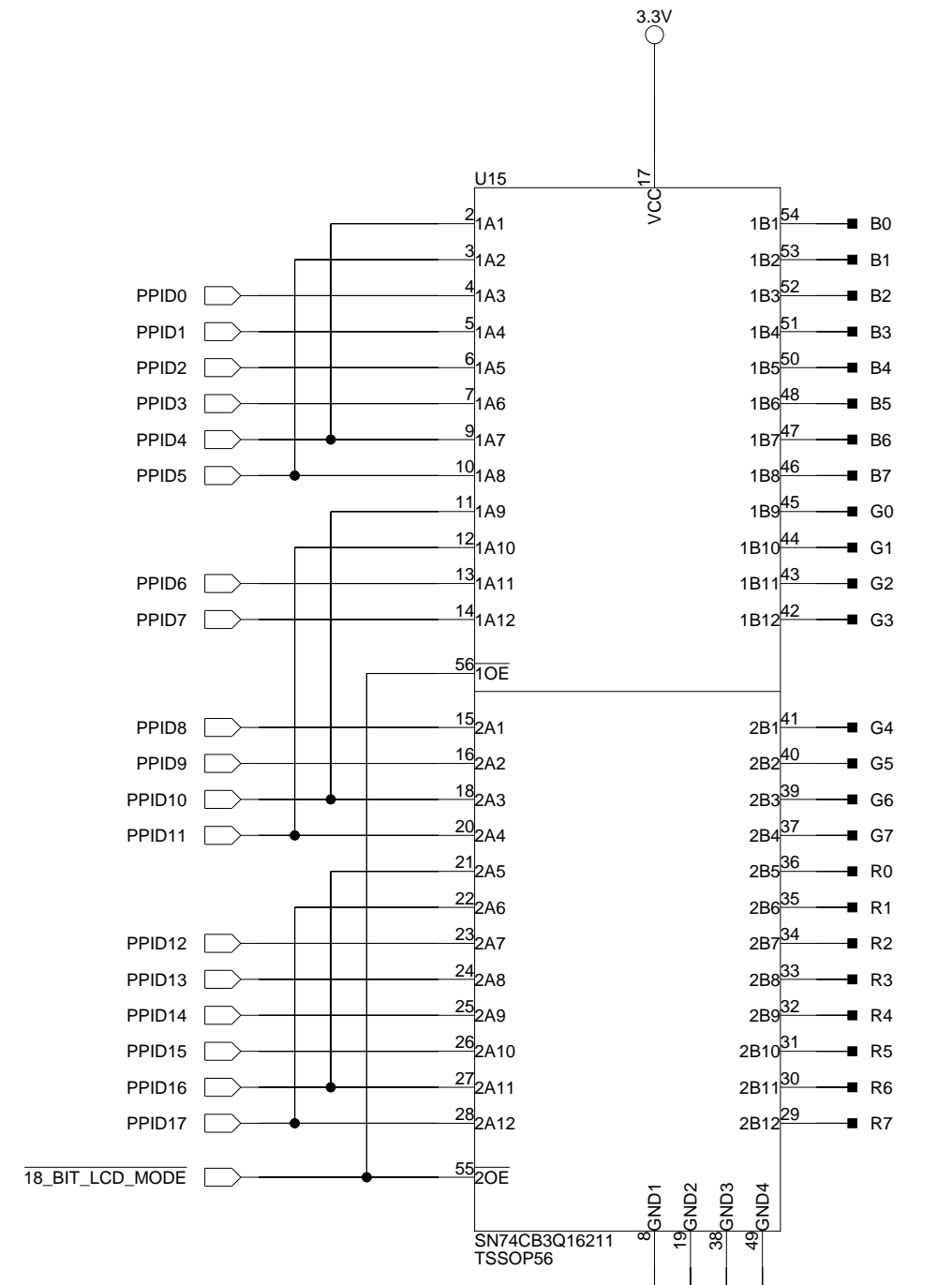

18-Bit Mode

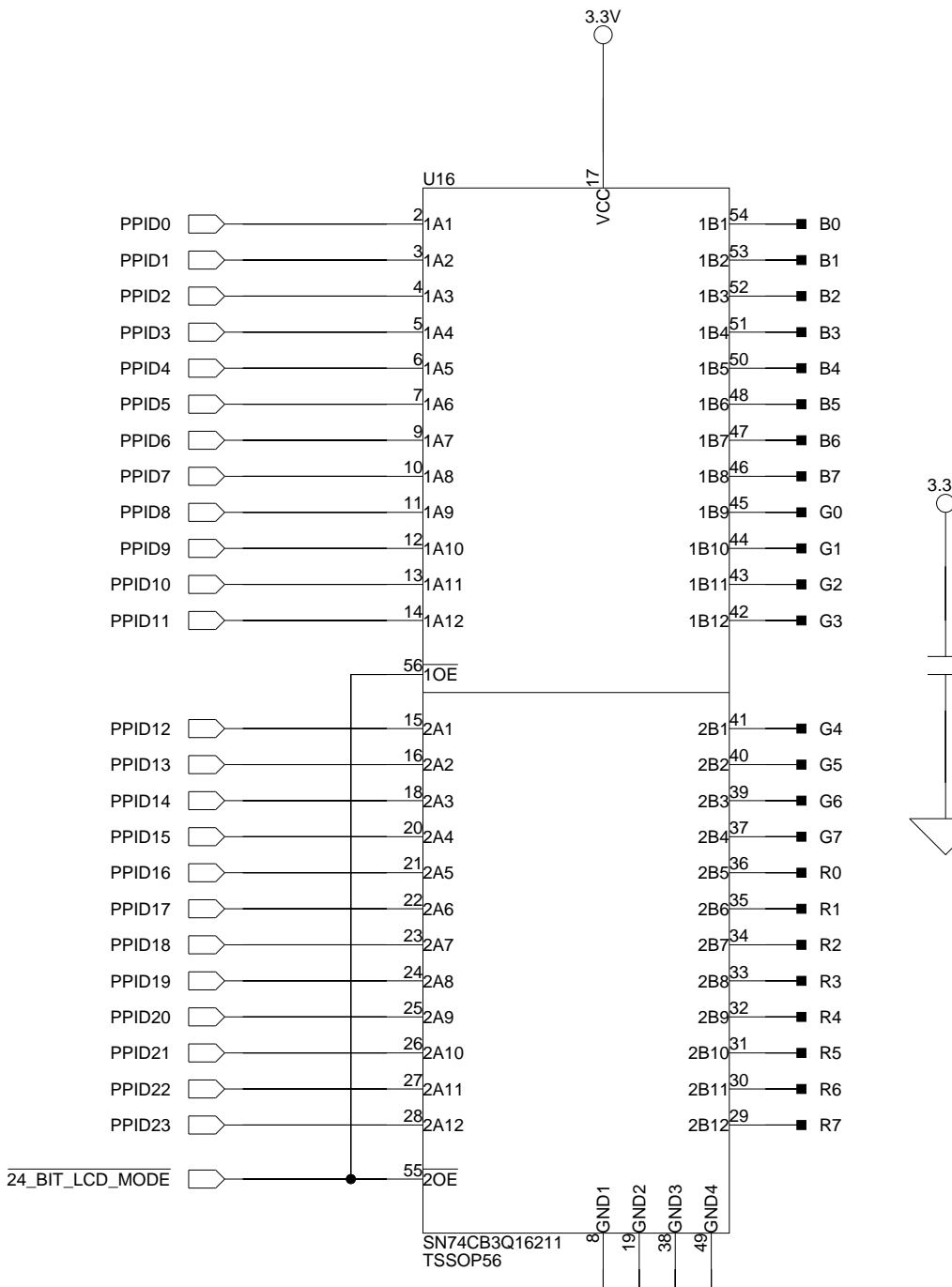

24-Bit Mode

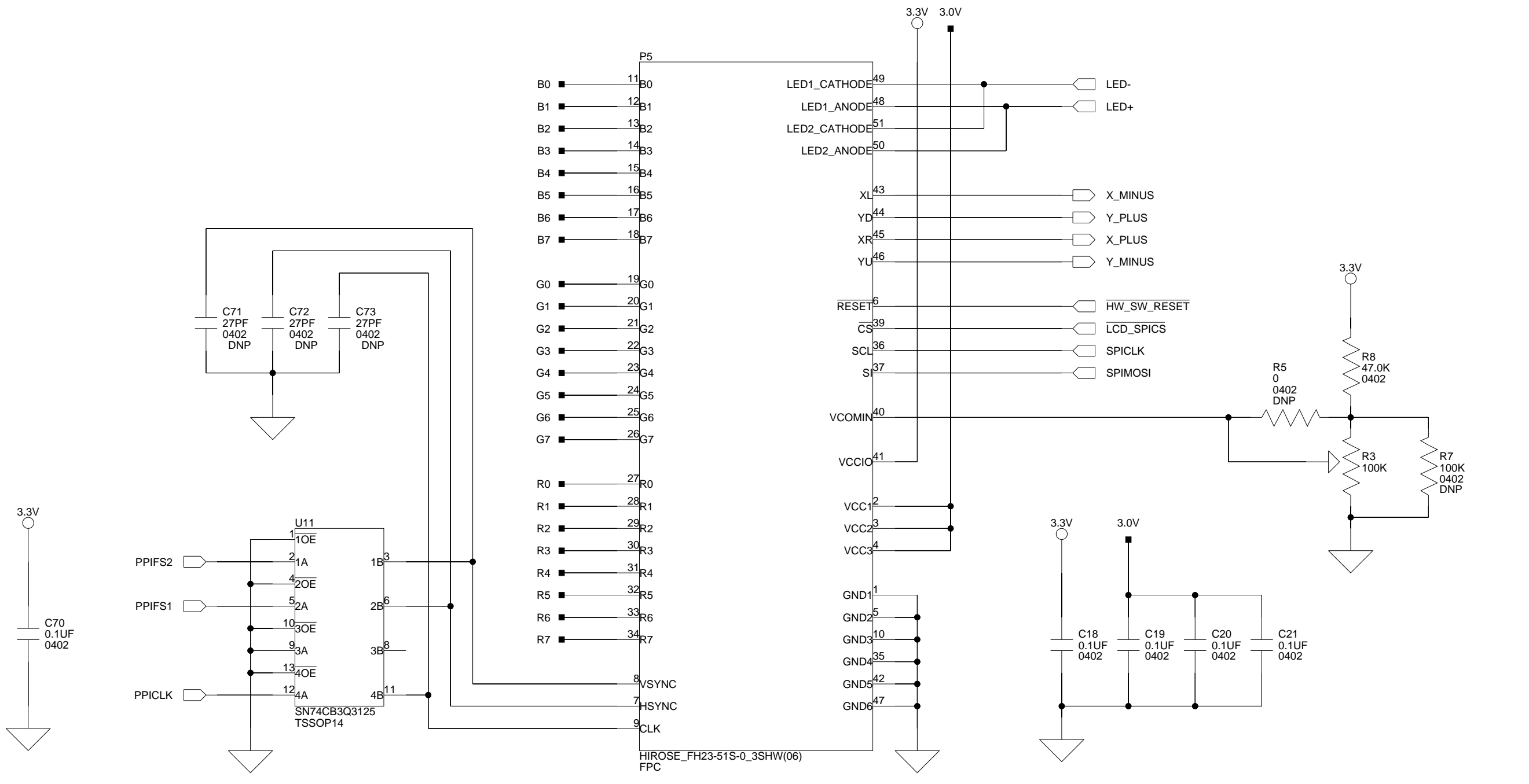

		20 Cotton Road Nashua, NH 03063 PH: 1-800-ANALOGD	
		Title WVGA/LCD EI3 Extender Board LCD Connector and Mode Switches	
Size C	Board No. A0254-2010	Rev 1.0	
Date 2/13/12	Sheet 6 of 8		Rev 1.0

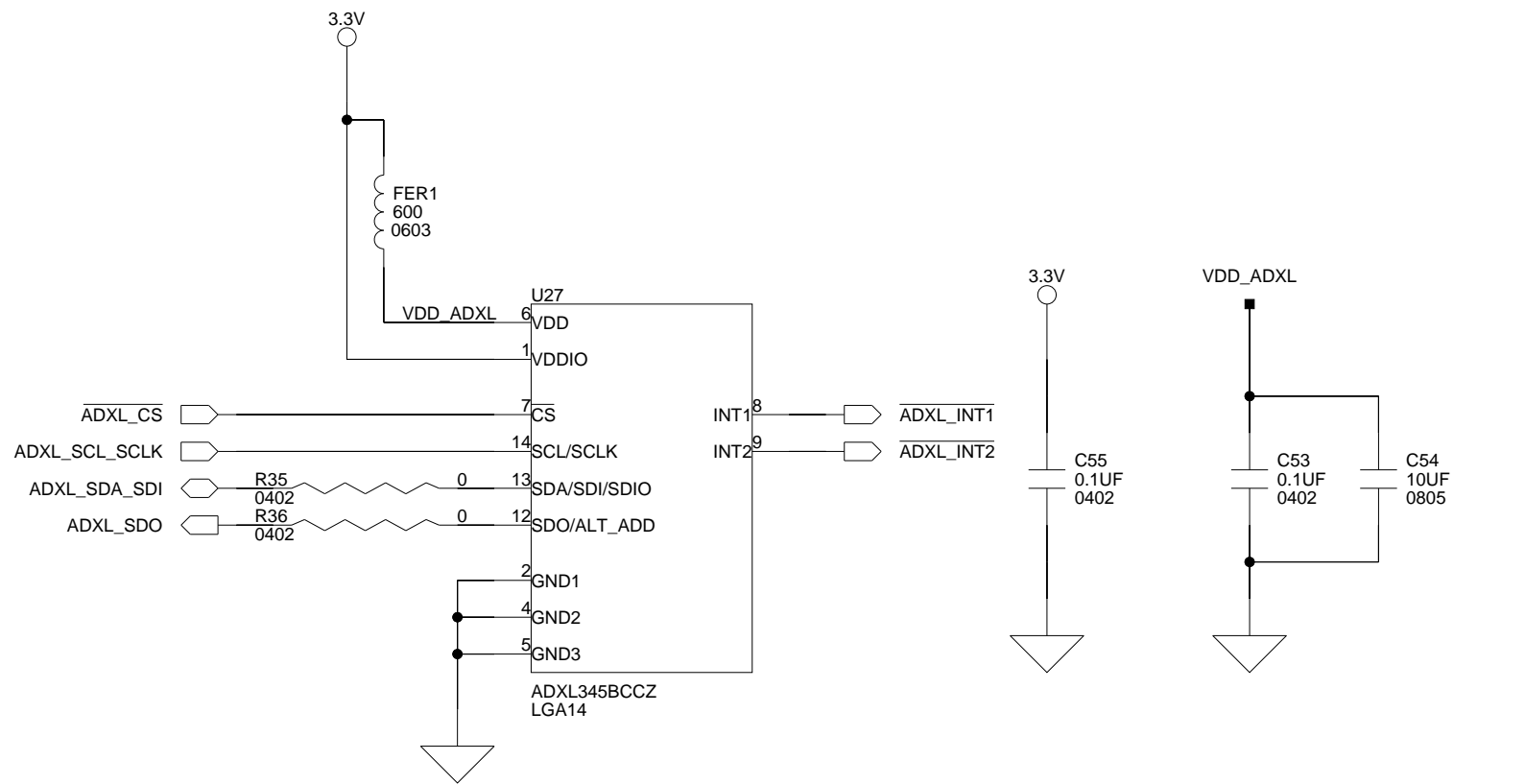
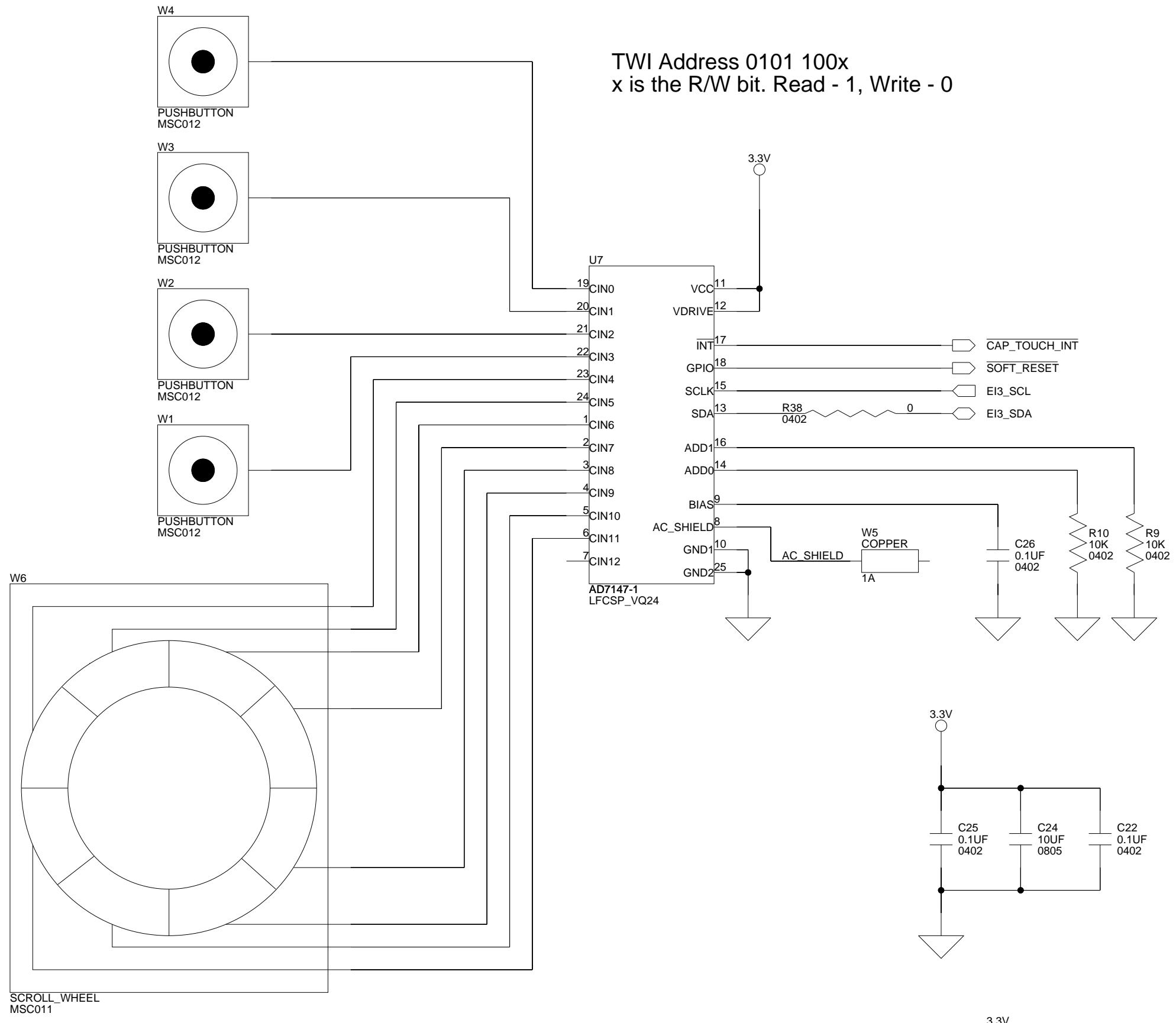
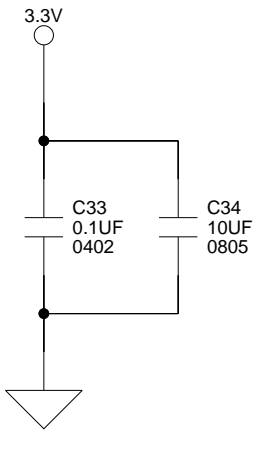
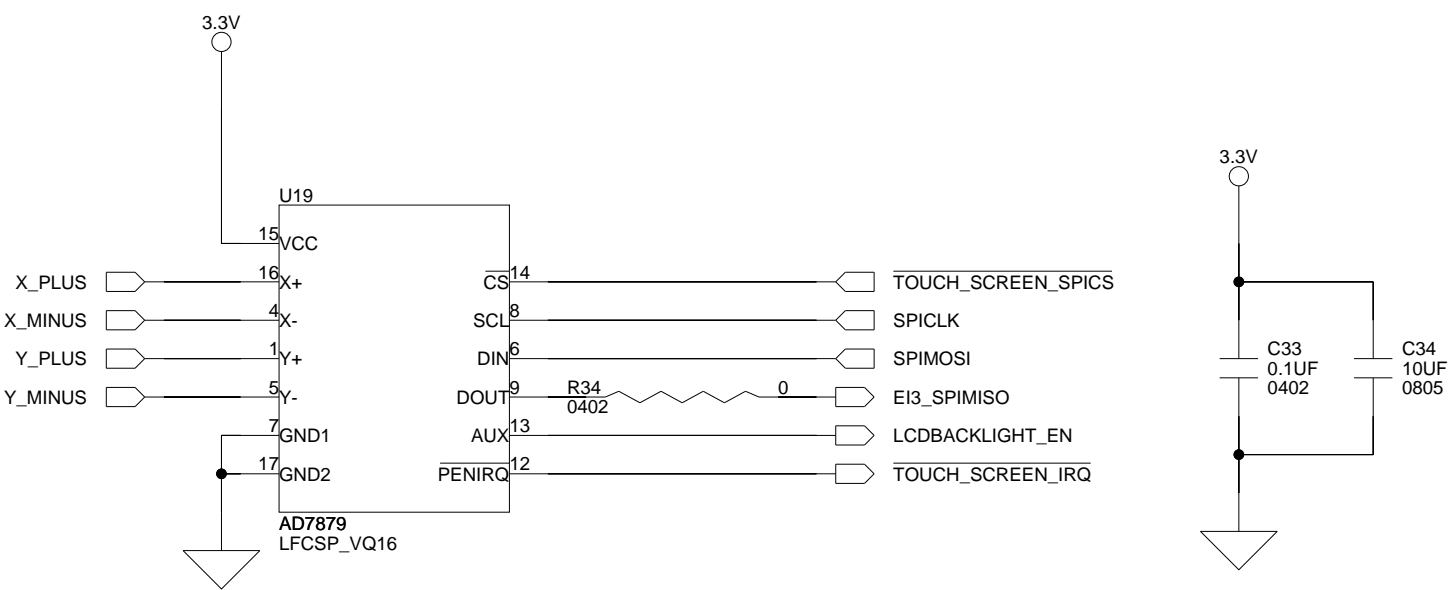

3.3V
TWI Address 0101 011x
x is the R/W bit. Read - 1, Write - 0

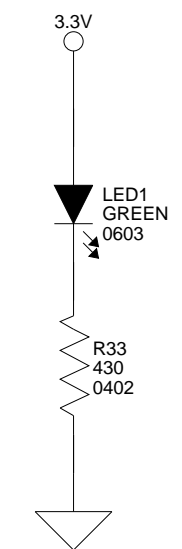

BACKLIGHT POWER

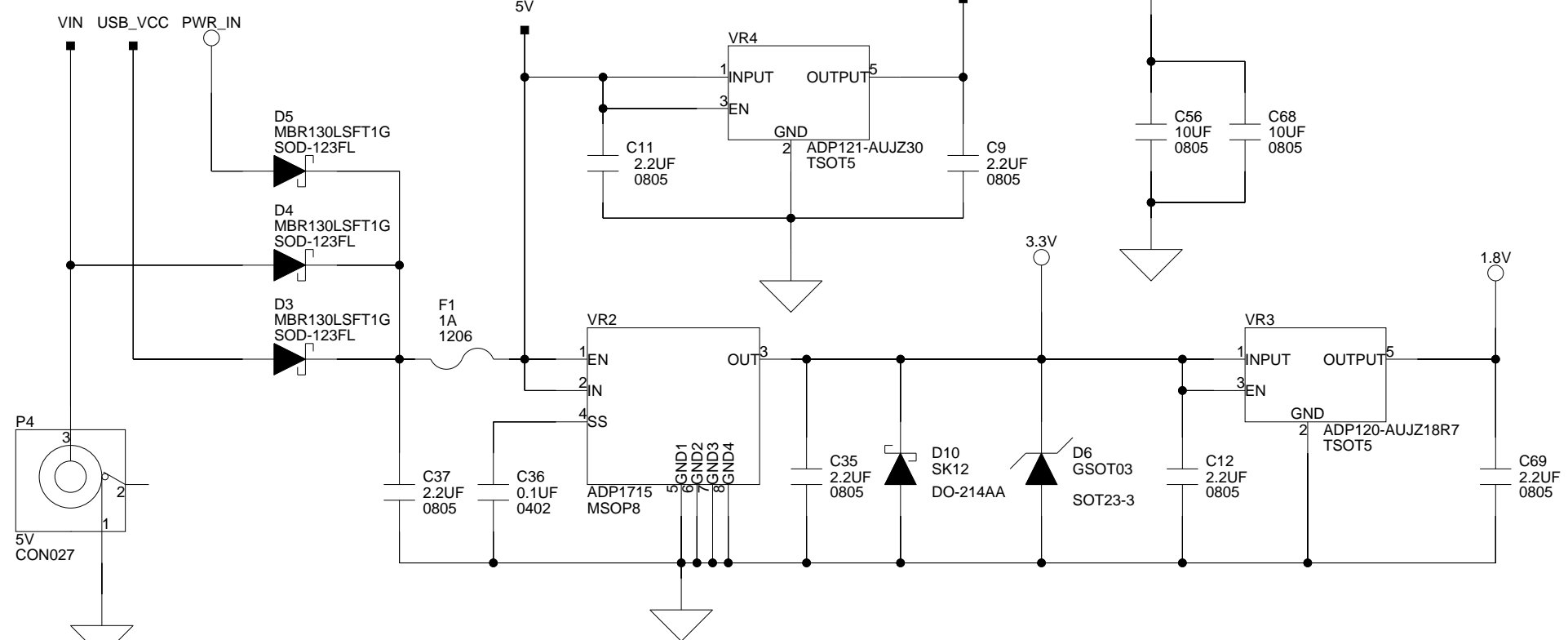
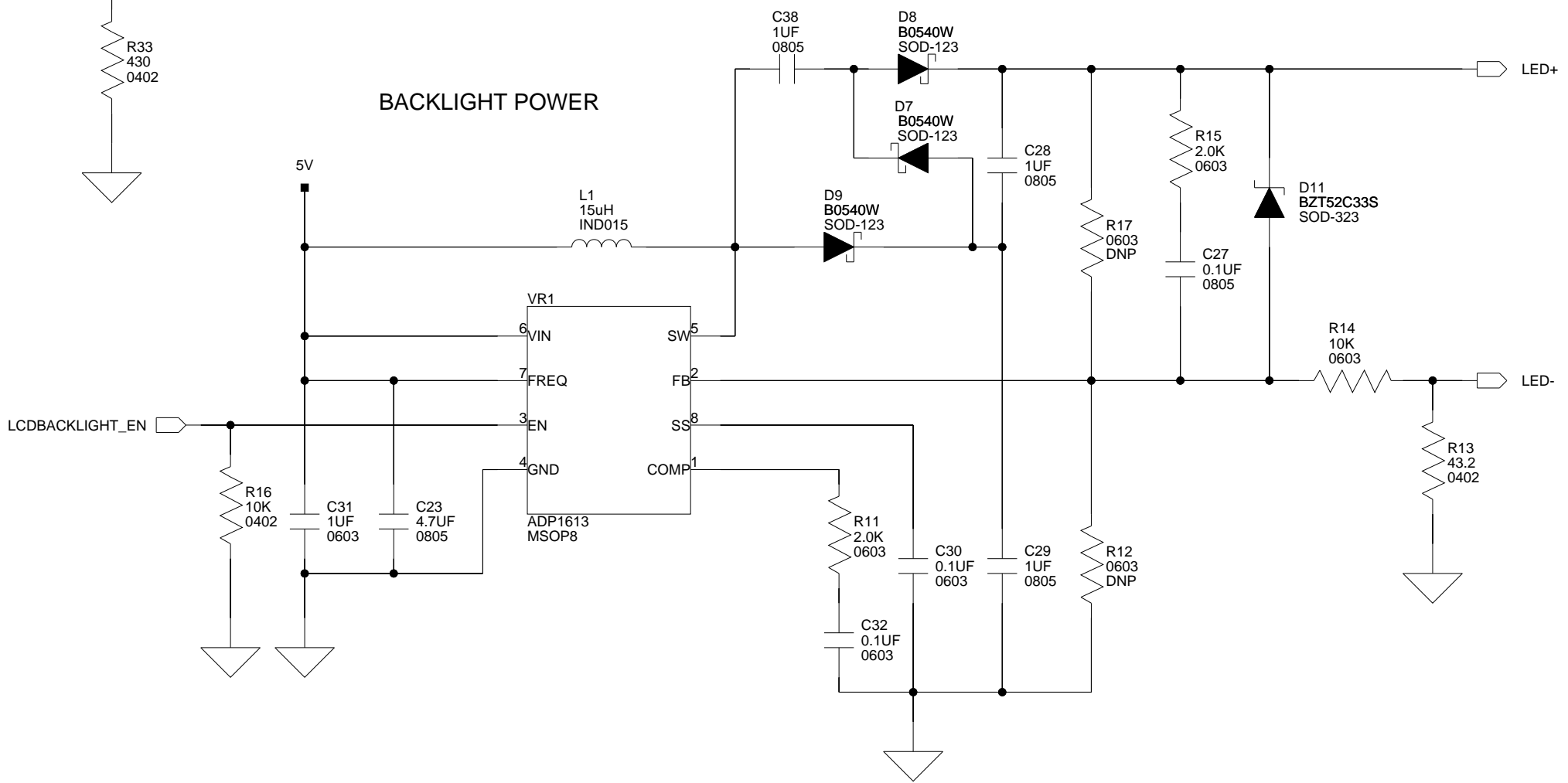

ANALOG DEVICES

20 Cotton Road
Nashua, NH 03063
PH: 1-800-ANALOGD

Title			WVGA/LCD EI3 Extender Board Accelerometer/TouchScreen/Cap Touch/Power		
Size C	Board No.	A0254-2010			Rev 1.0
Date	2/13/12	Sheet	7	of	8

These parts will be populated by internal people who want to use this board with the SDP.

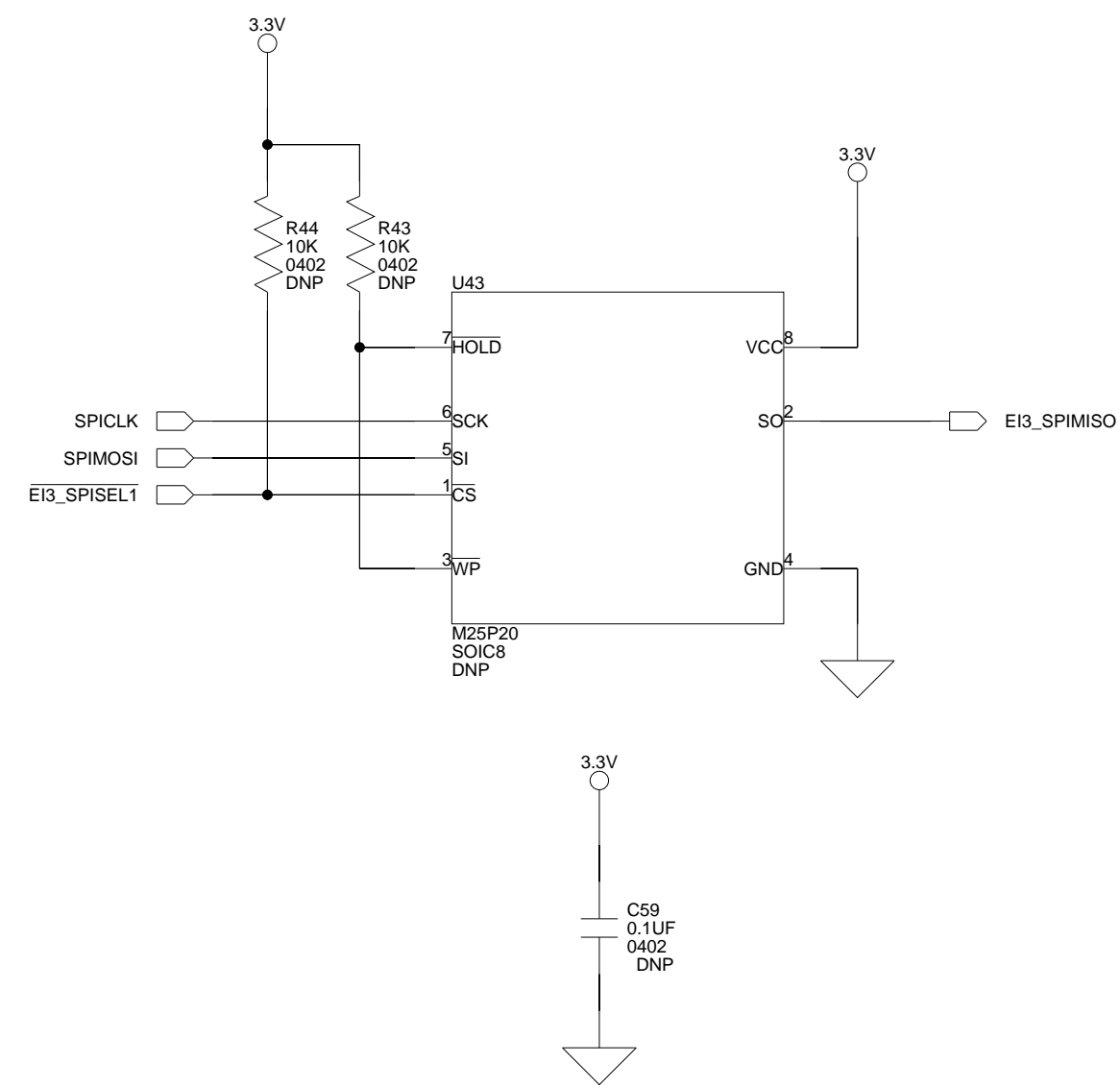
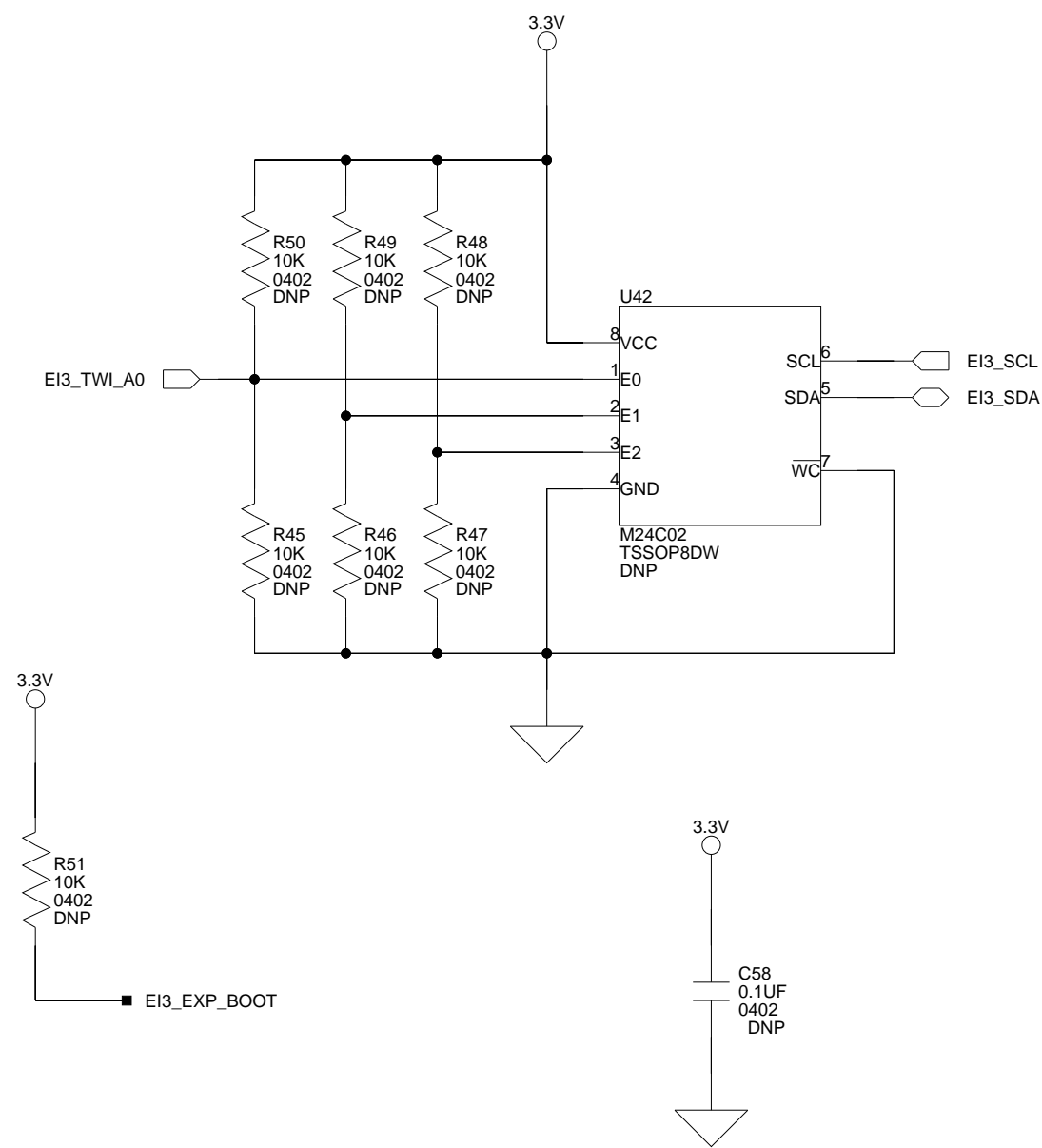

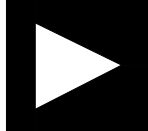
 ANALOG DEVICES		20 Cotton Road Nashua, NH 03063 PH: 1-800-ANALOGD	
		Title WVGA/LCD EI3 Extender Board TWI/SPI Flash	
Size C	Board No.	Rev A0254-2010 1.0	
Date	2/13/12	Sheet	8 of 8

I INDEX

A

AD7147 interrupt signal, [2-14](#)
AD7879 PENIRQ signal, [2-13](#)
AD7879 SPI chip select, [2-14](#)
ADXL345 interrupt signals, [2-14](#)
ADXL345 SPI chip select, [2-15](#)
ADXL345 TWI/SPI mode select, [2-14](#)
architecture, of this Extender Board, [2-2](#)

B

bill of materials, [A-1](#)
board design database, [1-8](#)
board schematic (WVGA/LCD EI3 Extender Board), [B-1](#)
bus switch example, [2-6](#)

C

capacitive touch controller, [1-5](#)
connectors
 diagram of locations, [2-16](#)
 J1-2 (expansion), [2-17](#)
 P1-2 (expansion), [2-17](#)
 P4 (power), [2-17](#)
 P5 (LCD), [1-4](#), [2-18](#)
contents, of this Extender Board package, [1-2](#)
customer support, [-x](#)

D

digital accelerometer, [1-6](#)

E

example programs, [1-7](#)
expansion interface III (EI3), [1-7](#), [2-17](#)

F

FET switches, [2-3](#), [2-4](#)

G

GPIO expander (U10), [2-9](#)
GPIO signals, [1-5](#), [2-9](#)

I

installation, of this Extender Board, [1-3](#)

L

LCD
 backlight, [1-4](#)
 connector (P5), [1-4](#), [2-18](#)
 mode select switch, [2-13](#)
 SPI chip select switch, [2-13](#)
 touch controller, [1-5](#)
 touch screen, [1-5](#)
LED1 (power), [2-18](#)

M

mechanical switch equivalent, [2-5](#), [2-7](#)

Index

O

operating systems, supported, [1-2](#)

P

package contents, [1-2](#)

parallel peripheral interface (PPI), [1-4](#)

power connector (P4), [2-17](#)

power LED (LED1), [2-18](#)

PPICLK_DIR select switch, [2-13](#)

PPICLK select, [1-4](#)

programmable controller, [1-5](#)

S

schematic, of WVGA/LCD EI3 Extender Board, [B-1](#)

serial peripheral interface (SPI), [1-4](#), [1-6](#)
SoftConfig (software-controlled switches)

examples, [2-3](#)

on the Extender Board, [2-9](#)

overview, [2-3](#)

programming, [2-7](#)

SPICS signals, [2-9](#)

supported operating systems, [1-2](#)

system architecture, of this Extender Board,
[2-2](#)

system requirements, [1-3](#)

T

touch controller, [1-5](#)

touch controller (capacitive), [1-5](#)

two-wire interface (TWI), [1-5](#), [1-6](#), [2-8](#)

Данный компонент на территории Российской Федерации

Вы можете приобрести в компании MosChip.

Для оперативного оформления запроса Вам необходимо перейти по данной ссылке:

<http://moschip.ru/get-element>

Вы можете разместить у нас заказ для любого Вашего проекта, будь то серийное производство или разработка единичного прибора.

В нашем ассортименте представлены ведущие мировые производители активных и пассивных электронных компонентов.

Нашей специализацией является поставка электронной компонентной базы двойного назначения, продукции таких производителей как XILINX, Intel (ex.ALTERA), Vicor, Microchip, Texas Instruments, Analog Devices, Mini-Circuits, Amphenol, Glenair.

Сотрудничество с глобальными дистрибьюторами электронных компонентов, предоставляет возможность заказывать и получать с международных складов практически любой перечень компонентов в оптимальные для Вас сроки.

На всех этапах разработки и производства наши партнеры могут получить квалифицированную поддержку опытных инженеров.

Система менеджмента качества компании отвечает требованиям в соответствии с ГОСТ Р ИСО 9001, ГОСТ РВ 0015-002 и ЭС РД 009

Офис по работе с юридическими лицами:

105318, г.Москва, ул.Щербаковская д.3, офис 1107, 1118, ДЦ «Щербаковский»

Телефон: +7 495 668-12-70 (многоканальный)

Факс: +7 495 668-12-70 (доб.304)

E-mail: info@moschip.ru

Skype отдела продаж:

moschip.ru

moschip.ru_4

moschip.ru_6

moschip.ru_9