

CM3-BT1

Extreme Rugged™, PCI-104 Single Board Computer with Intel® Atom™ Processor E3800 Series SOC

NEW

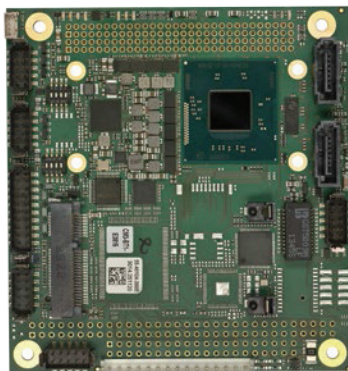

Features

- Single-core Intel® Atom™ or Celeron® Processors
- Up to 4GB DDR3L at 1333MHz
- Supports VGA and LVDS
- GbE, 1x SATA 3Gb/s
- 1x USB 3.0 + 2x USB 2.0, 8x GPIO
- Extreme Rugged™ operating temperature: -40°C +85°C
- Supports Smart Embedded Management Agent (SEMA) functions

Specifications

Core System

CPU	Single-core Intel® Atom™ or Celeron® Processor System-on-Chip Atom™ E3815 (1C), 1.46 GHz, 400 MHz Gfx, 5W Supports : single, dual or quad Out-of-Order Execution (OOE) processor cores, Intel® VT-x, Intel® SSE4.1 and SSE4.2, Intel® 64 architecture, IA 32-bit, PCLMULQDQ Instruction DRNG, Intel® Thermal Monitor (TM1 & TM2) Note: Availability of features may vary between processor SKUs.
Memory	Up to 4GB DDR3L-1066/1333 MHz DDR3L SO-DIMM
Embedded BIOS	AMI EFI with CMOS backup in 8MB SPI BIOS
Cache	Primary 32 KiB, 8-way L1 instruction cache and 24 KiB, 6-way L1 write-back data cache
Expansion Busses	PCI-104 (PCI)
SEMA Board Controller	Supports: Voltage/Current monitoring, Power Sequence debug support, AT/ATX mode control, Logistics and Forensic information, Flat Panel Control, General Purpose I ² C, Failsafe BIOS (dual BIOS), Watchdog Timer and Fan Control
Debug Headers	40-pin multipurpose flat cable connector Note: Use in combination with DB-40 debug module providing BIOS POST code LED, BMC access, SPI BIOS flashing, Power Testpoints, Debug LEDs

Video

GPU Feature Support	7th generation Intel® graphics core architecture with four execution units Supporting two independent displays 3D graphics hardware acceleration Support for DirectX 11, OCL 1.1, OGL ES Halt/2.0/1.1, OGL 3.2 Video decode hardware acceleration including support for H.264, MPEG2, MVC, VC-1, WMV9 and VP8 formats Video encode hardware acceleration including support for H.264, MPEG2 and MVC formats
LVDS	Single/dual channel 18/24-bit LVDS from eDP
VGA	Yes

Audio

Chipset	Intel® HD Audio integrated in SOC
Audio Codec	ALC886

Ethernet

Intel® MAC/PHY Interface	1x Intel® i210 (MAC/PHY) Ethernet controller 10/100/1000 GbE connection
--------------------------	--

I/O Interfaces

USB	3x USB 2.0 (1x on mSATA) + 1x USB 3.0
SATA	1x SATA 3Gb/s shared with mSATA
GPIO	8x
Serial	2x RS-232/485 (with full handshake)

LPC

LPC UART NCT5104D (Nuvoton)

Power

Standard Input	ATX = 5V±5% / 5Vsb ±5% AT = 5V±5%
Management	ACPI 5.0 compliant
Power States	C1-C6, S0, S3, S4, S5 (Wake on USB S3/S4, Wake on LAN S3/S4/S5)
ECO mode	Supports deep S5 (ECO mode) for power saving

Mechanical and Environmental

Form Factor	PCI-104 Version 2.3
Dimension	90 mm x 96 mm
Operating Temperature	Standard: 0°C to +60°C Extreme Rugged™: -40°C to +85°C
Humidity	5-90% RH operating, non-condensing 5-95% RH storage (and operating with conformal coating)
Shock and Vibration	IEC 60068-2-64 and IEC-60068-2-27
HALT	MIL-STD-202F, Method 213B, Table 213-I, Condition A and Method 214A, Table 214-I, Condition D Thermal Stress, Vibration Stress, Thermal Shock and Combined Test

Operating Systems

Standard Support	Windows 7/8 32/64-bit, Linux 32/64-bit
Extended Support (BSP)	WES7/8, WEC7, Linux, QNX, VxWorks

Functional Diagram

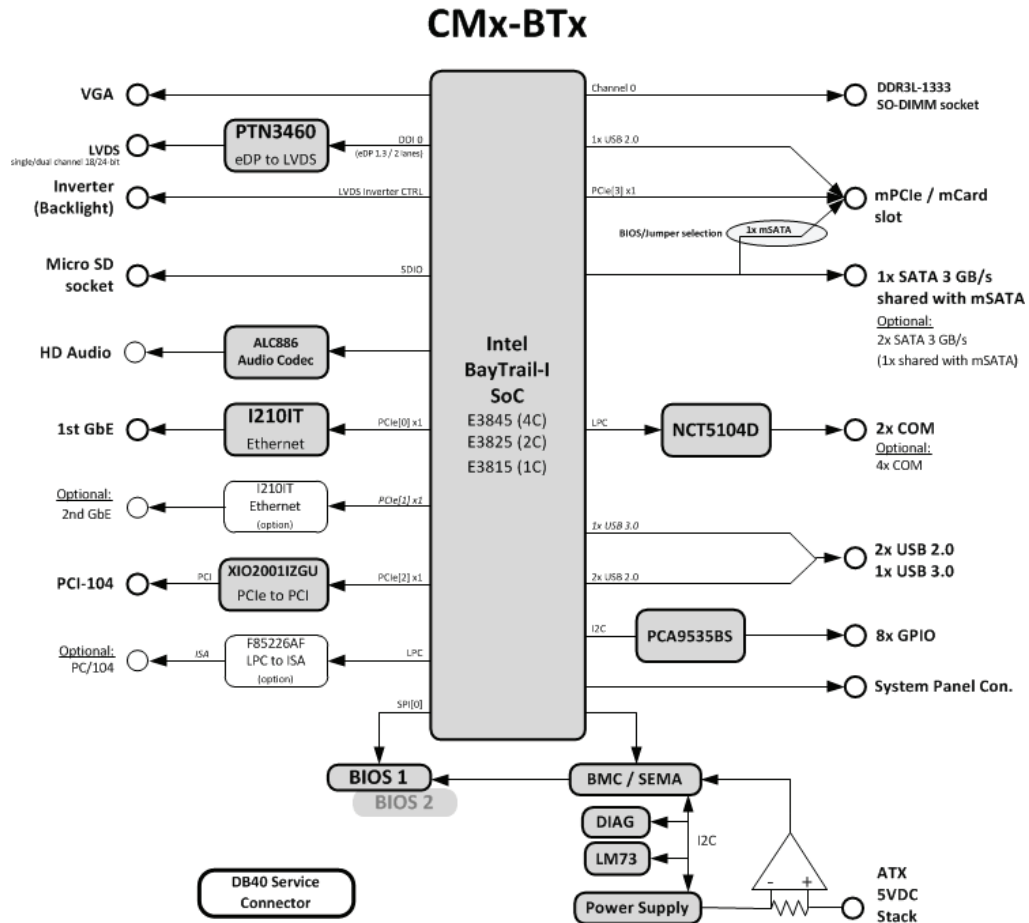

Ordering Information

Modules

Model Number	Description/Configuration
CM3-BT1-E3815	PCI-104, Atom E3815 (1C), 1.46 GHz, incl. heat spreader, Standard operating temperature: 0°C to +60°C

Accessories

Model Number	Description/Configuration
tbd	ETT screening -40°C to +85°C
CMx-BTx-X-10	CMx-BTx cable kit
CMx-BTx-TM-10	Passive low profile heatsink for CMx-BTx
CMx-BTx-TM-20	Active low profile heatsink for CMx-BTx (with fan)
DDR3L memory	Verified 2GB, 4GB DDR3L SODIMM memory available

CMx-BTx Standard Variant Comparison

Model Number	CM1-BT1-E3815	CM2-BT2-E3825	CM3-BT4-E3845	CM3-BT1-E3815
Form factor	PC/104	PC/104-Plus	PCI-104	PCI-104
PCI Bus (PCI-104)	No	Yes	Yes	Yes
ISA Bus (PC/104)	Yes	Yes	No	No
CPU	E3815	E3825	E3845	E3815
CPU cores	1	2	4	1
VGA	1x	1x	1x	1x
LVDS	1x	1x	1x	1x
SATA	config 1: 2, config 2: 1	config 1: 2, config 2: 1	config 1: 2, config 2: 1	config 1: 1, config 2: 0
mSATA	0, 1	0, 1	0, 1	0, 1
mPCIe	1, 0	1, 0	1, 0	1, 0
MicroSD card slot	1x	1x	1x	0x
GbE	2x	2x	2x	1x
COM	4x	4x	4x	2x
GPIO	8x	8x	8x	8x
HD Audio	1x	1x	1x	1x
USB 2.0	3x	3x	3x	3x
USB 3.0	1x	1x	1x	1x

Данный компонент на территории Российской Федерации

Вы можете приобрести в компании MosChip.

Для оперативного оформления запроса Вам необходимо перейти по данной ссылке:

<http://moschip.ru/get-element>

Вы можете разместить у нас заказ для любого Вашего проекта, будь то серийное производство или разработка единичного прибора.

В нашем ассортименте представлены ведущие мировые производители активных и пассивных электронных компонентов.

Нашей специализацией является поставка электронной компонентной базы двойного назначения, продукции таких производителей как XILINX, Intel (ex.ALTERA), Vicor, Microchip, Texas Instruments, Analog Devices, Mini-Circuits, Amphenol, Glenair.

Сотрудничество с глобальными дистрибьюторами электронных компонентов, предоставляет возможность заказывать и получать с международных складов практически любой перечень компонентов в оптимальные для Вас сроки.

На всех этапах разработки и производства наши партнеры могут получить квалифицированную поддержку опытных инженеров.

Система менеджмента качества компании отвечает требованиям в соответствии с ГОСТ Р ИСО 9001, ГОСТ РВ 0015-002 и ЭС РД 009

Офис по работе с юридическими лицами:

105318, г.Москва, ул.Щербаковская д.3, офис 1107, 1118, ДЦ «Щербаковский»

Телефон: +7 495 668-12-70 (многоканальный)

Факс: +7 495 668-12-70 (доб.304)

E-mail: info@moschip.ru

Skype отдела продаж:

moschip.ru

moschip.ru_4

moschip.ru_6

moschip.ru_9