

Table of Contents

TD2 Series Time Delay Relays, per MIL-PRF-83726/28, /29, /30, & /31	5-2 – 5-5
Double-pole, Electrically Held, 5 Amps and Less	
FCB-205 Series	5-6 – 5-8
Four-pole, Electrically Held, 5 Amps and Less	
FCB-405 Series	5-9 – 5-11
Double-pole, Electrically Held, 15 Amps and Less	
FCA-210 Series	5-12 – 5-14
FCA-212 Series	5-15 – 5-17
FCA-215 Series	5-12 – 5-14
Four-pole, Electrically Held, 15 Amps and Less	
FCA-410 Series	5-18 – 5-20
FCA-415 Series	5-18 – 5-20
Single-pole, Electrically Held, 25 Amps and Less	
FCA-125 Series	5-21 – 5-23
Three-pole, Electrically Held, 25 Amps and Less	
FCA-325 Series	5-24 – 5-26
Three-pole, Electrically Held, 25 Amps and Less, with Auxiliary Contacts	
FCAC-325 Series	5-27 – 5-29
Single-Pole, Electrically Held, 50 Amps or Less	
FCA-150	5-30 – 5-33
Single-Pole, Electrically Held, 50 Amps and Less, Normally Closed, with Auxiliary Contacts	
FCA-150NC	5-34 – 5-37
Single Pole, Electrically Held, 50 Amps and Less, with Auxiliary Contacts	
FCAC-150	5-38 – 5-41
Selection and Application Guide	5-42
Cross Reference - Socket to Relay	5-43

TD2 Series Time Delay Relay

Product Facts

- **Qualified to:**
 - MIL-PRF-83726/28
 - MIL-PRF-83726/29
 - MIL-PRF-83726/30
 - MIL-PRF-83726/31
- **Fixed delay on operate, fixed delay on release, adjustable delay on operate & adjustable delay on release**
- **Meets or exceeds electrostatic discharge MIL-STD-1686 Class Non-Sensitive**
- **Welded hermetically sealed enclosure occupies about 1 in³ (16.4 cm³)**
- **10A, 2 form C (DPDT) output contacts**

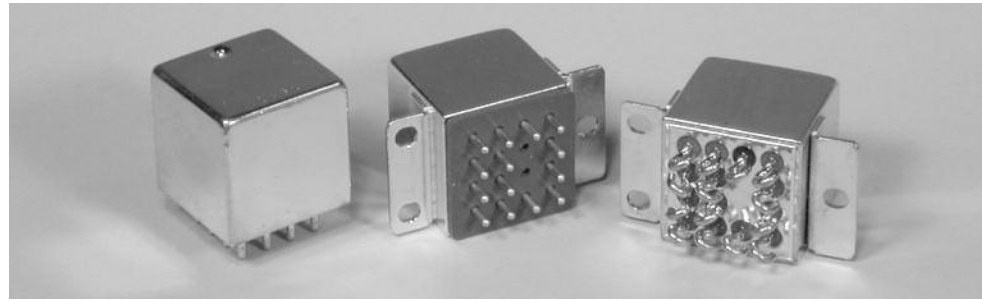

TD2 series time delay relays are available for delay on operate or delay on release operation. Either can be supplied as fixed or resistor adjustable types. Both military and commercial versions are offered.

These products consist of solid state timing circuits controlling our FCA-210 series relays, providing 2 Form C (DPDT) output contacts rated 10 amps. The internal timing circuit uses an R/C controlled oscillator with a program-

mable digital pulse counter, gating a semiconductor switch to operate the relay. Timing is independent of whether the controlling voltage is a ramp or step function.

For the adjustable models the user specifies a one decade range in seconds, within which the required delay will be set. This range is programmed internally at the time of manufacture. The required delay is obtained by calculating the oscillator timing resistor as

follows and connecting it externally to terminals 1D - 3D as below.

$$R_{EXT} = [(T_1 / T_0) - 1] 100K \text{ Ohms}$$

T_0 = Minimum time of selected decade in seconds.

T_1 = Required time delay.

EXAMPLE

Selected Range = 3-30 sec

Required Time = 15 sec

$$R_{EXT} = [(15/3) - 1] 100K = 400K$$

Timing Action and Terminal Wiring

Delay On Operate:

The time delay starts on the application of input voltage to X1-X2. The timing circuit energizes the end of the time delay period.

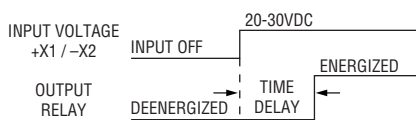

Fixed Model

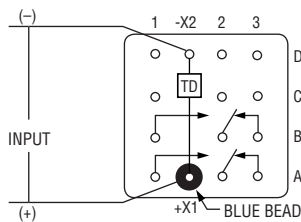

Adjustable Model

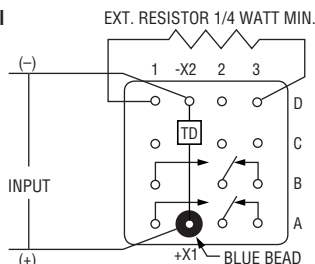

Delay On Release:

The input voltage is continuous to X1-X2. When the control voltage is applied to C1-X2 the timing circuit and the relay are both energized. The time delay starts when the control voltage is shut off.

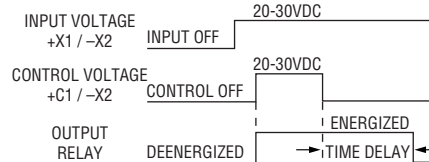

Fixed Model

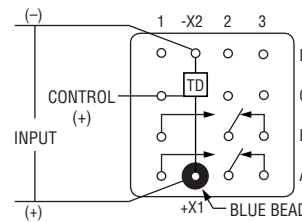

Adjustable Model

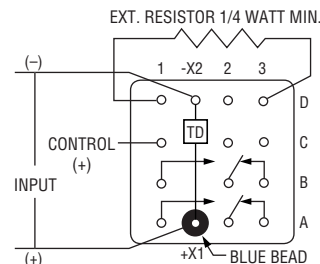

Terminal designations shown in the diagrams above are for reference only. They do not appear on the relay header.

TD2 Series Time Delay Relay (Continued)

Specifications

Timing Data

Timing Action	Delay on Operate or Delay on Release
Time Delay, Fixed – M83726/28, /29 and Commercial 28C, 29C	Select from 0.1 to 600 sec for Commercial Models Select from 0.1 to 500 sec for Mil-Spec Models
Time Delay, Adjustable – M83726/30, /31 and Commercial 30C, 31C	Select one decade between 0.1 to 1.0 and 60 to 600 seconds
Timing Accuracy (note 1)	±10% of Nominal Value
Recycle Time (note 2)	50 ms, max., to next cycle.
Power Interrupts	Accuracy is not affected by power interruptions up to 1 ms spaced at least 10ms apart.

Input Data

Input Voltage	28 Vdc nominal, range 20 - 32 Vdc
Duty Rating	Continuous
Input Current	110 mAdc Max @ 25°C
Control Voltage (applies only to Delay on Release type)	20 - 32 Vdc
Control Current	15 mAdc Max (applies only to delay on release types)
Input Voltage Polarity Protection	The timer will be inoperative during, and undamaged by, reversal of the polarity of the input voltage.

Output Data

Contact Form	2 Form C (DPDT)
Contact Material	Silver Cadmium Oxide, Gold plated
Contact Rating in Amps (Continuous Duty)	

Type of Load	Life (Min.) Cycles	28 Vdc	115 Vac 400Hz	115/200 Vac – 3 phase 400 Hz.	60 Hz.*
Resistive	100 x 10 ³	10	10	10	2.5
Inductive	20 x 10 ³	8	8	8	2.5
Motor	100 x 10 ³	4	4	4	2.0
Lamp	100 x 10 ³	2	2	2	1.0

* 60 Hz. loads are rated at 10 x 10³ cycles.

Overload Current	40 Adc; 60A, 400 Hz.
Rupture Current	50 Adc; 80A, 400 Hz.
Max. Contact Drop at 10A	Initial 0.150V; After Life 0.175V

Electrical Data

Electrostatic Discharge Withstand Voltage	16,000V
Transients (note 3):	
Positive Transients	+80V
Self-generated Transients	±50V, Max.
Spike Susceptibility	±600V, 10 μs, Max.
Insulation Resistance (note 4)	1,000 megohms at 500Vdc, between each pin and case
Dielectric Strength (note 4)	1,000Vrms at 60 Hz at sea level, between case and all pins connected together

Environmental Data

Ambient Temperature Range, Operating	-55°C to +125°C
Altitude	80,000 feet maximum
Shock Resistance	100 G's, 6 ms.
Vibration Resistance, Sinusoidal	Z & Y Enclosure: 30 G's, 33-3000Hz.; X & W Enclosure: 20 G's, 33-3000Hz.

Mechanical Data

Approximate Weight	2.5 oz. (71g) Max.
--------------------	--------------------

NOTES

- The accuracy requirement applies to any combination of operating temperature and voltage. Add ±10ms for timing less than one second.
- Recycle time to assure that the next timing cycle will be completed. Units can be recycled during timing and after time-out:
Delay on operate models – Power must be OFF the input at least 10 ms. Delay on release models – Power must be ON the control terminal at least 10 ms.
- Transient specifications are based on a maximum duty cycle of 1/50.
- All wired terminals must be connected together during this test. Dielectric withstanding voltage and insulation resistance are measured between all mutually insulated wired terminals and between all these terminals and case.
- Inductive loads must be diode suppressed.

TD2 Series Time Delay Relay (Continued)

Outline Dimensions

The standard terminal types and enclosures are illustrated below with dimensions expressed as inches ± 0.010 and (millimeters ± 0.25).

Terminals

All terminals on 0.200 (5.4) centers.

CODE "P"

Socket Pins – Gold Plated

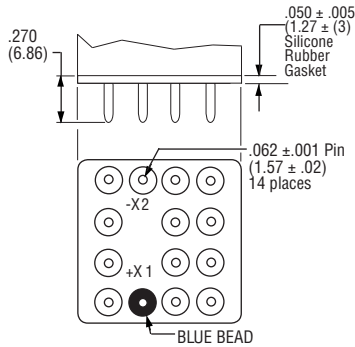

CODE "T"

Circuit Board Pins – Tin/Lead Plated

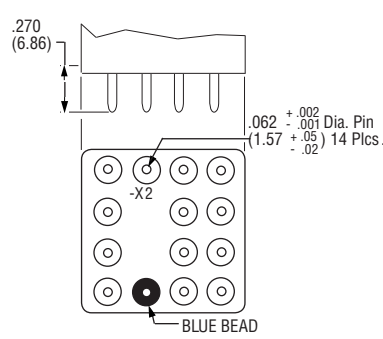

CODE "S"

Solder Hooks

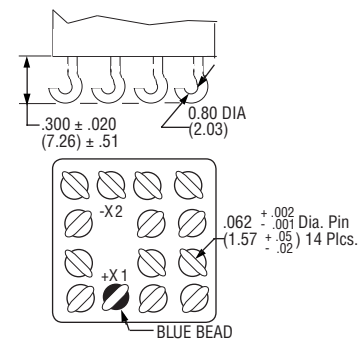

Enclosures

All Enclosures have cupro-nickel cans bright acid tin/lead plated after assembly to terminal headers.

CODE "Z"

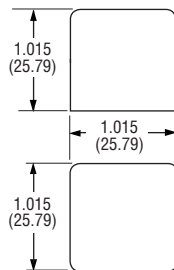

CODE "Y"

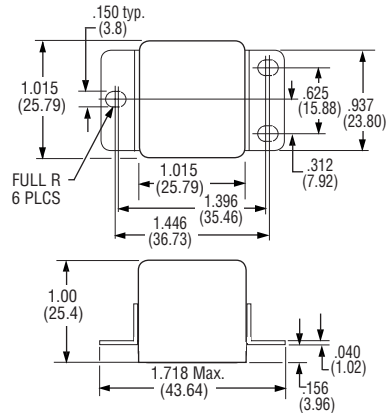

CODE "X"

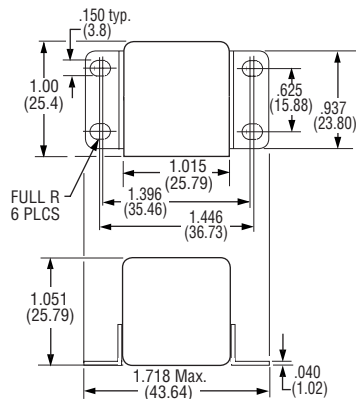

CODE "W"

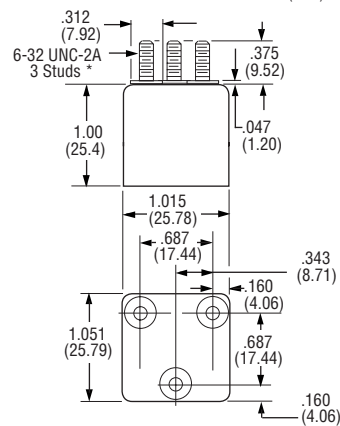

*Metric threads available. To specify use "M" in place of "W"

For factory-direct application assistance, phone 419-521-9500 or fax 419-526-2749.

TD2 Series Time Delay Relay (Continued)

**Part Numbering System
Mil-Spec Types**

Typical Mil-Spec Part Number	TD2	28-	5002	P
Series:				
TD2 = Time delay relay with 2 pole, 10A output				
Mil-Spec Model:				
28 = M83726/28 (Fixed, Delay on Operate)				
29 = M83726/29 (Fixed, Delay on Release)				
30 = M83726/30 (Adjustable, Delay on Operate)				
31 = M83726/31 (Adjustable, Delay on Release)				
Time Delay Range (Within 0.1 to 500 seconds):				
For /28 and /29 types (fixed types), the delay is expressed in milliseconds in a four-digit code. The first three digits are significant. The fourth is the number of zeros following the first three. Example: 5002 is 50 seconds.				
For /30 and /31 types (adjustable types), the delay decade range is expressed in milliseconds in a four-digit code representing the upper limit of the range. The first three digits are significant. The fourth is the number of zeros following the first three. Example: 1001 is 1 second, so the range is 0.1 to 1 second.				
Terminals:				
P= Socket Pin Terminals				
S= Solder Hook Terminals				

Note: Mil-spec models have "Y" type enclosure.

Commercial Types

Typical Commercial Part Number	TD2	28C-	1001	P	Y
Series:					
TD2 = Time delay relay with 2 pole, 10A output					
Commercial Model:					
28C = Fixed, Delay on Operate (COTS version of M83726/28)					
29C = Fixed, Delay on Release (COTS version of M83726/29)					
30C = Adjustable, Delay on Operate (COTS version of M83726/30)					
31C = Adjustable, Delay on Release (COTS version of M83726/31)					
Time Delay Range (Within 0.1 to 600 seconds):					
For fixed types, the delay is expressed in milliseconds in a four-digit code. The first three digits are significant. The fourth is the number of zeros following the first three. Example: 5002 is 50 seconds.					
For adjustable types, the delay decade range is expressed in milliseconds in a four-digit code representing the upper limit of the range. The first three digits are significant. The fourth is the number of zeros following the first three. Example: 1001 is 1 second, so the range is 0.1 to 1 second.					
Terminals:					
P= Socket Pin Terminals					
S= Solder Hook Terminals					
T= Solder Pin Terminals					
Enclosure					
W = Mounting Studs					
X = Horizontal Flange Mount					
Y = Raised Vertical Flange Mount					
Z = No Mount					

NOTE: Commercial versions are available with timing ranges outside of .1 to 600 sec. range.

For factory-direct application assistance, phone 419-521-9500 or fax 419-526-2749.

FCB-205 Series, 5 Amperes, DPDT



The Series FCB-205 relay is a polarized single-side stable design, where the flux from a permanent magnet provides the armature holding force in the deactivated state, and its flux path is switched and combined with the coil flux in the operated state. This results in appreciably

increased contact pressure in both states over that of a spring return nonpolar design. We also manufacture other forms of the FCB relay:

FCB-405 — 5 Amp 4PDT Relay

General Specifications

Temperature Rating —
-70°C TO + 125°C

Altitude — 300,000 Feet

Shock* —

Z, Y, & X Enclosures —

200 g for 6 mS

W & M Enclosures (Stud Mtg.) —

100 g for 6 mS

T Enclosure (Socket Mounted in Track) —
50 g for 11 mS

Vibration, Sinusoidal* —

Z, Y, & X Enclosures —

0.12 DA 10 to 70 Hz, 30 g 70-3000Hz

W & M Enclosures (Stud Mtg.) —

0.12 DA 10 to 57 Hz, 20 g 57-3000Hz

T Enclosure (Socket Mounted in Track) —

0.06 DA 10 to 57 Hz, 10 g 57 to 500Hz,
20 g 500 to 3000 Hz

Vibration, Random* —

Z, Y, & X Enclosures —

0.4 g²/Hz 50-2000Hz

T, W & M Enclosures —

0.2 g²/Hz 50-2000Hz

Dielectric Strength —

At Sea Level —

All circuits to ground and circuit to
circuit — 1000 V rms

Coil to ground — 1000 V rms

At 80,000 Feet — 250 V rms

Insulation Resistance —

Initial (500 VDC) — 100 M Ω Min.

After Life or Environmental Tests —

50 M Ω Min.

Operate Time at Nominal

Voltage — 4 ms or less

Release Time at Nominal

Voltage — 4 ms or less

* Max. contact opening under vibration
or shock 10 microseconds

Product Facts

- Hermetically Sealed
- All Welded Construction
- Balanced Force
- Permanent Magnet Drive
- Contacts rated low level to 5 Amps VDC and 115/200 VAC 400 Hz, 3 Phase
- Weight .54 ounces max. (15.4 grams)
- Qualified to M83536/1, /2

Contact Rating — Amperes Ratings Are Continuous Duty

Type of Load	Life (Min.) Cycles x 10 ³	28 VDC	115VAC 400Hz	115/200VAC 400Hz, 3 ϕ
Resistive	100	5	5	5
Inductive	20	3	5	5
Motor	100	2	3	3
Lamp	100	1	1	1

*60 Hz loads rated for 10,000 operations

Low Level Switching Capability: With contacts operating a load of 10 to 50 microamperes at 10 to 50 millivolts, the contact resistance miss detection level shall be 100 ohms max. Cycling rate is 1 to 12 per second, for 100,000 operations.

Overload Current — 20 AMPS DC, 30 AMPS 400Hz

Rupture Current — 25 AMPS DC, 40 AMPS 400Hz

Contact Make Bounce — 1.0 MILLISECOND AT NOMINAL VOLTAGE

Max. Contact Drop at 5 Amps — INITIAL 0.100 VOLTS

End of Life — 0.125 VOLTS

Coil Data

Coil Code	Nominal Voltages	Freq. Hz	DC Res. (B)	Over Temperature Range		
				Pickup or Below Volts	Dropout or Above Volts	Must Hold Voltage (C)
1	6	DC	20 Ω	4.5	0.3	2.5
2	12	DC	95 Ω	9.0	0.75	4.5
3	28	DC	500 Ω	18.0	1.5	7.0
4 (A)	28	DC	500 Ω	18.0	1.5	7.0
5	48	DC	1600 Ω	36.0	2.5	14.0

A. CODE 4 COILS HAVE BACK EMF SUPPRESSION TO 42 VOLTS MAX.

B. DC COIL RESISTANCE \pm 10% AT 25°C

C. RELAY WILL STAY IN PICKED-UP STATE DOWN TO MUST HOLD VOLTAGES SHOWN.

D. MAX. OVERVOLTAGE: 6 & 12 VDC COILS 120% OF NOMINAL; ALL OTHERS 110% OF NOMINAL.

FCB-205 Series, 5 Amperes, DPDT (Continued)

Below are shown the standard terminal types and the enclosures available. Specify the assembly as indicated under How To Order. Dimensions are shown in inches $\pm .010$ and (Millimeters $\pm .25$).

Terminals

CODE "A" Socket Pin Terminals

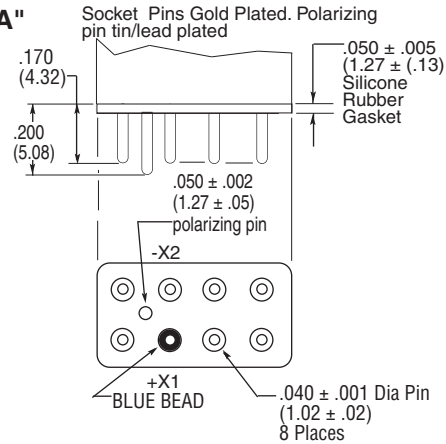

CODE "B" Solder Pin Terminals

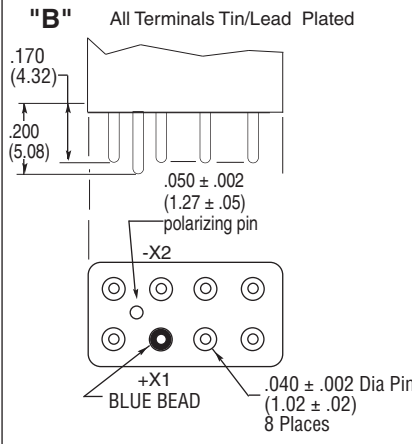

CODE "C" Solder Hook Terminals

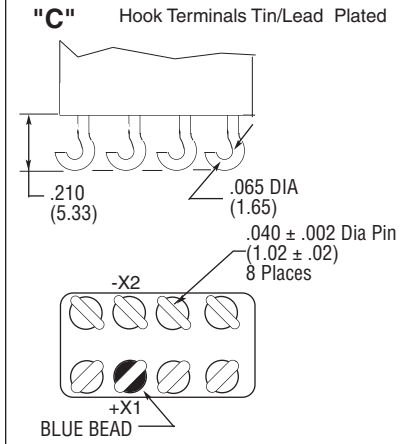

CODE "H" 90° Solder Pins

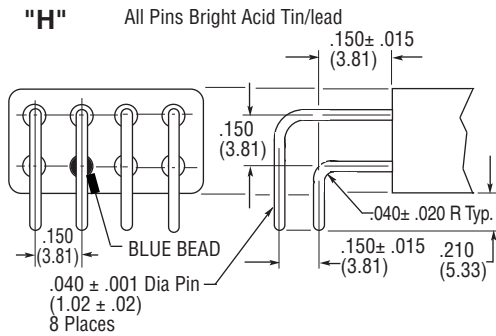

CODE "Z"

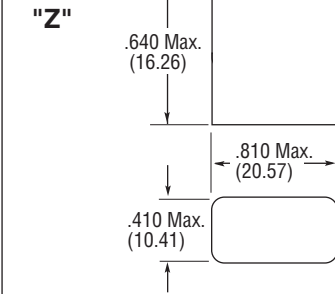

CODE "Y"

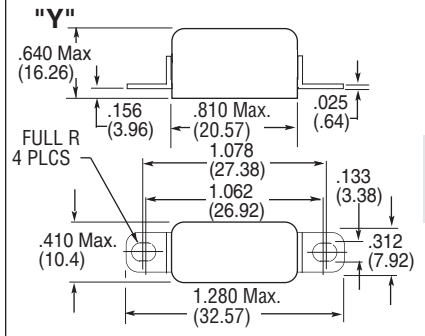

Enclosures

All Enclosures have Cupro-Nickel Cans bright acid tin/lead plated after assembly to terminal headers.

Dimensions: Inches $\pm .010$ (mm $\pm .25$)

Enclosure "T" is for use with track mounted sockets and requires socket pin terminals, but no gasket. The gasket is included in the socket assembly.

CODE "X"

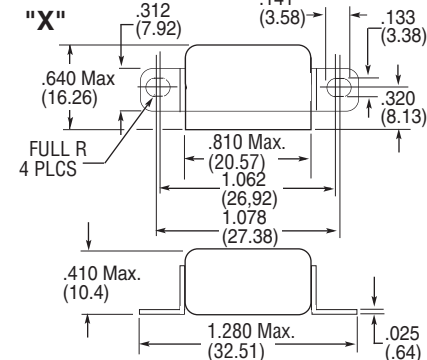

CODE "W"

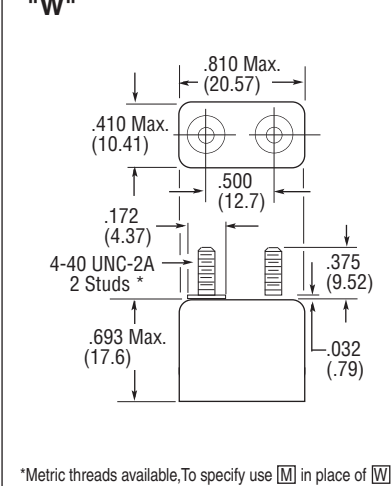

*Metric threads available, To specify use **M** in place of **W**

CODE "T"

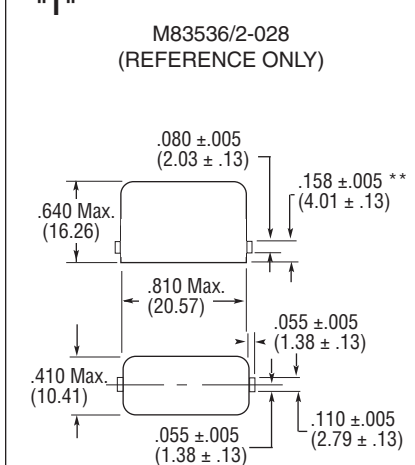

NOTE: FOR USE WITH TRACK MOUNT PER MIL-R-6106/23

** MEASURED FROM SURFACE OF HEADER

FCB-205 Series, 5 Amperes, DPDT (Continued)

Terminal Wiring

DC Coils

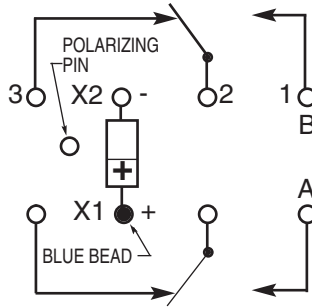

Transient Suppression

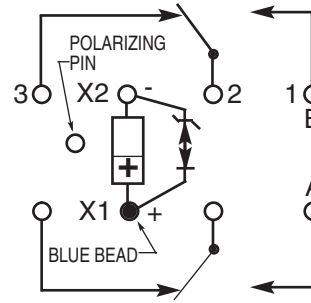

NOTE: Polarity must be observed with DC coil supply. Relay is polarized with a permanent magnet and will not operate or be damaged by reverse polarity.

Diodes used in transient suppression and in AC rectifier circuits have peak inverse voltage rating of 600 VDC minimum. Zener diodes have a minimum rating of 1 watt.

Terminal designations are for reference only and do not appear on the header.

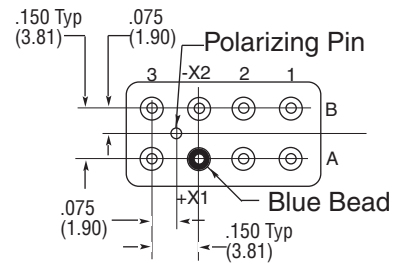

TERMINAL VIEW

HOW TO ORDER

FCB-205-A Y 4

RELAY TYPE _____

TERMINALS (Socket Pins) _____

ENCLOSURE (With Flanges) _____

COIL (28 VDC With Transient Suppression). _____

* The part number example shown on this page is for catalog items. For a list of specific QPL part numbers, please see the index in Section 15.

FCB-405 Series, 5 Amperes, 4PDT



Product Facts

- Hermetically Sealed
- All Welded Construction
- Balanced Force
- Permanent Magnet Drive
- Contacts rated low level to 5 Amps 28 VDC and 115/200 VAC 400 Hz, 3 Phase
- Weight .93 ounces max. (26.4 grams)
- Qualified to M83536/5 & /6

The Series FCB-405 relay is a polarized single-side stable design, where the flux from a permanent magnet provides the armature holding force in the deactivated state, and its flux path is switched and combined with the coil flux in the operated state. This results in appreciably

increased contact pressure in both states over that of a spring return nonpolar design. We also manufacture other versions of this relay:

FCB-205 — 5 Amp DPDT Relay

General Specifications

Temperature Rating —
-70°C TO + 125°C

Altitude — 300,000 Feet

Shock* —

Z & Y Enclosures —

200 g for 6 mS

W, X & M Enclosures —

100 g for 6 mS

T Enclosure (In Track) —

50 g for 11 mS

Vibration, Sinusoidal* —

Z & Y Enclosures —

30 g 70-3000Hz

W, X & M Enclosures —

20 g 70-3000Hz

T Enclosure (Socket Mounted in Track) —

20 g 500-3000 Hz

Vibration, Random* —

Z & Y Enclosures —

0.4 g²/Hz 50-2000Hz

T, W, X & M Enclosures —

0.2 g²/Hz 50-2000Hz

Dielectric Strength —

At Sea Level —

All circuits to ground and circuit to

circuit — 1000 V rms

Coil to ground — 1000 V rms

At 80,000 Feet — 250 V rms

Insulation Resistance —

Initial (500 VDC) — 100 MΩ Min.

After Life or Environmental Tests —

50 MΩ Min.

Operate Time at Nominal

Voltage — 6 ms or less

Release Time at Nominal

Voltage — 6 ms or less

* Max. contact opening under vibration or shock 10 microseconds

Contact Rating — Amperes Ratings Are Continuous Duty

Type of Load	Life (Min.) Cycles x 10 ³	28 VDC	115VAC 400Hz	115/200VAC 400Hz-3Ø
Resistive	100	5	5	5
Inductive	20	3	5	5
Motor	100	2	3	3
Lamp	100	1	1	1

Low Level Switching Capability: With contacts operating a load of 10 to 50 microamperes at 10 to 50 millivolts, the contact resistance miss detection level shall be 100 ohms max. Cycling rate is 1 to 12 per second, for 100,000 operations.

Overload Current — 20 AMPS DC, 30 AMPS 400Hz

Rupture Current — 25 AMPS DC, 40 AMPS 400Hz

Contact Make Bounce — 1.0 MILLISECOND AT NOMINAL VOLTAGE

Max. Contact Drop at 5 Amps — INITIAL 0.100 VOLTS

End of Life — 0.125 VOLTS

Coil Data

Coil Code	Nominal Voltages	Freq. Hz	DC Res. (B)	Over Temperature Range		
				Pickup or Below Volts	Dropout or Above Volts	Must Hold Voltage (C)
1	6	DC	25 Ω	4.5	0.3	2.5
2	12	DC	78 Ω	9.0	0.75	4.5
3	28	DC	400 Ω	18.0	1.5	7.0
4 (A)	28	DC	400 Ω	18.0	1.5	7.0
5	48	DC	1275 Ω	36.0	2.5	14.0

A. CODE 4 COILS HAVE BACK EMF SUPPRESSION TO 42 VOLTS MAX.

B. DC COIL RESISTANCE ± 10% AT 25°C

C. RELAY WILL STAY IN PICKED-UP STATE DOWN TO MUST HOLD VOLTAGES SHOWN.

D. MAX. OVERVOLTAGE: 6 & 12 VDC COILS 120% OF NOMINAL; ALL OTHERS 110% OF NOMINAL.

FCB-405 Series, 5 Amperes, 4PDT (Continued)

Below are shown the standard terminal types and the enclosures available. Specify the assembly as indicated under How To Order. Dimensions are shown in inches $\pm .010$ and (Millimeters $\pm .25$).

Terminals

CODE

"A"

Socket Pins - All DC Coils

PIN TERMINALS ARE GOLD PLATED

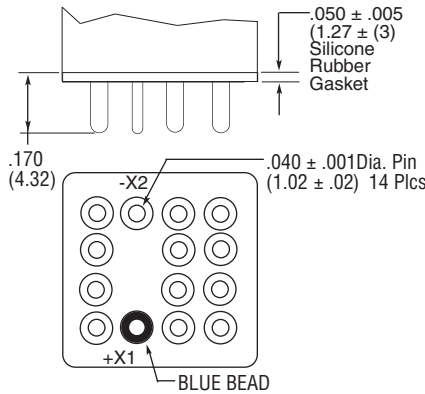

CODE

"B"

Solder Pin Terminals

PIN TERMINALS TIN/LEAD PLATED

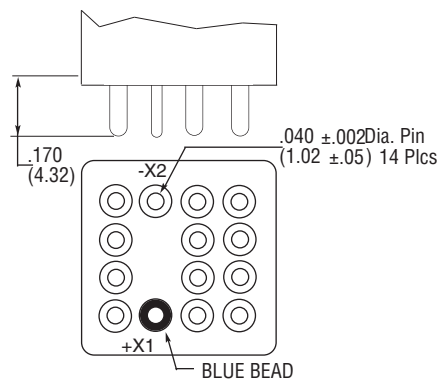

CODE

"C"

Solder Hook Terminals

HOOK TERMINALS TIN/LEAD PLATED

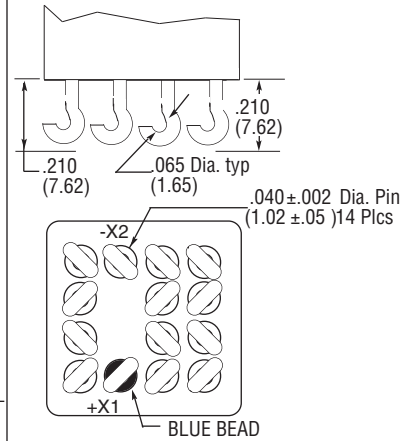

CODE

"T"

M83536/6-025
(REFERENCE ONLY)

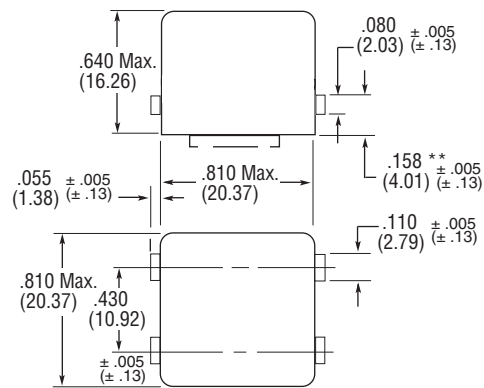

** Measured from surface of header

Enclosures

All Enclosures have cupro-Nickel cans bright acid tin/lead plated after assembly to terminal headers.
Dimensions: Inches $\pm .010$ (mm $\pm .25$)
Code "T" used only with track-mounted Sockets. Requires code "A" pin terminals. Gasket is included in the socket assembly.

CODE

"Z"

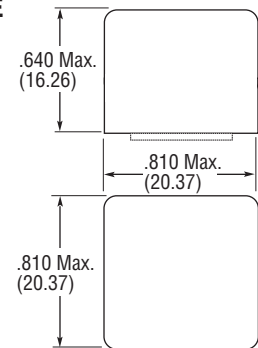

CODE

"Y"

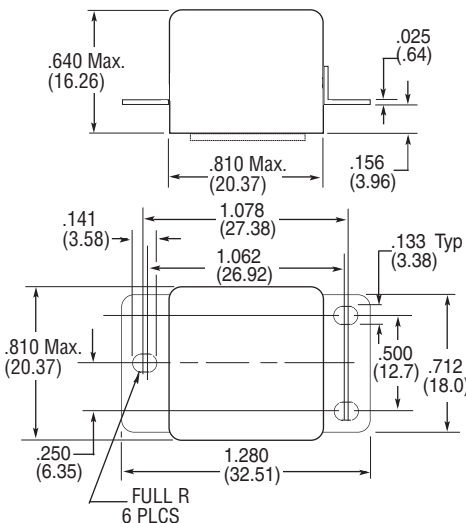

CODE

"W"

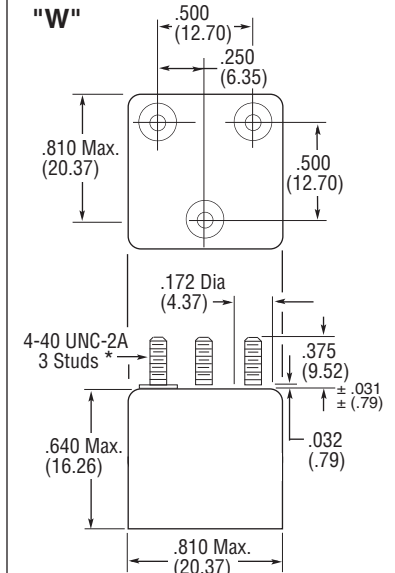

CODE

"X"

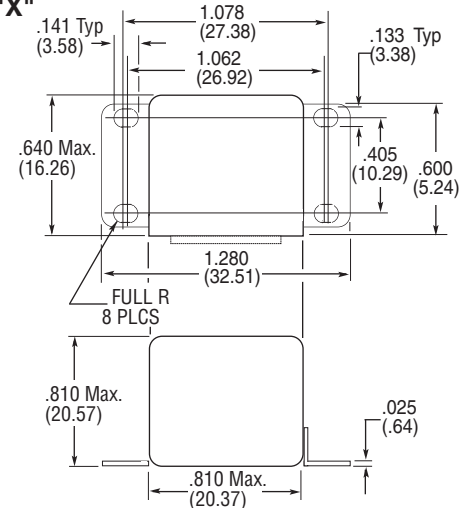

FCB-405 Series, 5 Amperes, 4PDT (Continued)

Terminal Wiring

DC Coils

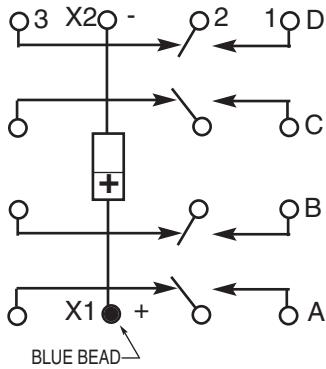

DC Coils with Transient Suppression

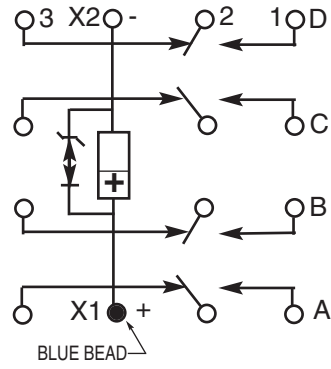

NOTE: Polarity must be observed with DC coil supply. Relay is polarized with a permanent magnet and will not operate or be damaged by reverse polarity.

Diodes used in transient suppression and in AC rectifier circuits have peak inverse voltage rating of 600 VDC minimum. Zener diodes have a minimum rating of 1 watt.

Terminal designations are for reference only and do not appear on the header.

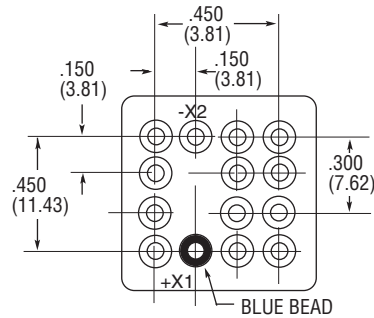

TERMINAL VIEW

HOW TO ORDER

FCB-405-A Y 4

RELAY TYPE _____

TERMINALS (Socket Pins) _____

ENCLOSURE (With Flanges) _____

COIL (28 VDC With Transient Suppression). _____

* The part number example shown on this page is for catalog items. For a list of specific QPL part numbers, please see the index in Section 15.

FCA-210 Series, 10 Amperes, DPDT



Product Facts

- Hermetically Sealed
- All Welded Construction
- Balanced Force
- Permanent Magnet Drive
- Contacts — Silver Cadmium Oxide with Gold Plating
- Coils for DC, 50 to 400Hz and 400Hz AC
- Weight 1.6 ounces max. (45.4 grams)
- Qualified to M83536/9, /10

The Series FCA-210 relay is a polarized single-side stable design, where the flux from a permanent magnet provides the armature holding force in the deactivated state, and its flux path is switched on the operated state. This results in appreciably increased contact pressure in both states over that of a spring return nonpolar design. We also

manufacture other versions of this relay:

FCA-410 — 10 Ampere 4PDT Relay

FCA-610 — 10 Ampere 6 PDT Relay

Available:

FCA-215 — 15 Ampere DPDT Relay, Has the same specifications as the FCA-210 except is rated at 15 amps. (Commercial Only)

General Specifications

- Temperature Rating** — -70°C TO + 125°C
- Altitude** — 300,000 Feet
- Shock*** — Z, Y, & X Enclosures — 200 g for 6 mS
W & M Enclosures (Stud Mtg.) — 100 g for 6 mS
- Vibration, Sinusoidal*** — Z, Y, & X Enclosures — 30 g 33-3000Hz
W & M Enclosures (Stud Mtg.) — 20 g 33-3000Hz
- Vibration, Random*** — Z, Y, & X Enclosures — 0.4 g²/Hz 50-2000Hz
W & M Enclosures (Stud Mtg.) — 0.2 g²/Hz 50-2000Hz
- Dielectric Strength** — At Sea Level — All circuits to ground and circuit to circuit — 1250 V rms
Coil to ground — 1000 V rms
At 80,000 Feet — 350 V rms
- Insulation Resistance** — Initial (500 VDC) — 100 MΩ Min.
After Life or Environmental Tests — 50 MΩ Min.
- Operate Time at Nominal Voltage** — DC Relays — 10 ms or less
AC Relays — 15 ms or less
- Release Time at Nominal Voltage** — DC Relays — 10 ms or less
AC Relays — 50 ms or less
- * Max. contact opening under vibration or shock 10 microseconds

Contact Rating — Amperes Ratings Are Continuous Duty

Type of Load	Life (Min.) Cycles x 10 ³	28 VDC	115VAC 400Hz	115/200VAC 3Ø	
				400Hz	60Hz*
Resistive	100	10	10	10	2.5
Inductive	20	8	8	8	2.5
Motor	100	4	4	4	2.0
Lamp	100	2	2	2	1

*60 Hz loads rated for 10,000 operations

Overload Current — 40 AMPS DC, 60 AMPS 400Hz

Rupture Current — 50 AMPS DC, 80 AMPS 400Hz

Contact Make Bounce — 1 MILLISECOND AT NOMINAL VOLTAGE

Max. Contact Drop at 10 Amps — INITIAL 0.100 VOLTS

End of Life — 0.125 VOLTS

Coil Data

Coil Code	Nominal Voltages	Freq. Hz	DC Res. AC Amps (B)	Over Temperature Range		
				Pickup or Below Volts	Dropout or Above Volts	Must Hold Voltage (C)
1	6	DC	20 Ω	4.5	0.3	2.5
2	12	DC	80 Ω	9.0	0.75	4.5
3	28	DC	320 Ω	18.0	1.5	7.0
4 (A)	28	DC	320 Ω	18.0	1.5	7.0
5	48	DC	920 Ω	32.0	2.5	14.0
6	28	400Hz	180 mA	22.0	1.25	10.0
7	28	50/400Hz	100 mA	22.0	1.25	10.0
8	115	400 Hz	40 mA	90.0	5.0	40.0
9	115	50/400 Hz	30 mA	95.0	5.0	40.0

A. CODE 4 COILS HAVE BACK EMF SUPPRESSION TO 42 VOLTS MAX.

B. DC COIL RESISTANCE ± 10% AT 25°C; AC COIL MAX. CURRENT AT NOMINAL VOLTAGE.

C. RELAY WILL STAY IN PICKED-UP STATE DOWN TO MUST HOLD VOLTAGES SHOWN.

D. MAX. OVERVOLTAGE: 6 & 12 VDC COILS 120% OF NOMINAL; ALL OTHERS 110% OF NOMINAL.

E. COILS AVAILABLE FOR OTHER VOLTAGES AND FOR AC 50/60HZ.

NOTE: Only DC Coil Models are QPL Approved.

FCA-210 Series, 10 Amperes, DPDT (Continued)

Below are shown the standard terminal types and the enclosures available. Specify the assembly as indicated under How To Order. Dimensions are shown in inches ± .010 and (Millimeters ± .25).

Terminals

SOCKET PINS ARE GOLD PLATED
POLARIZING PINS ARE TIN/LEAD PLATED
CIRCUIT BOARD PINS ARE TIN/LEAD PLATED
DIMENSIONS EXCEPT AS NOTED:
INCHES ± .010 (MILLIMETERS ± .25)

CODE "A" Socket Pins - All DC Coils

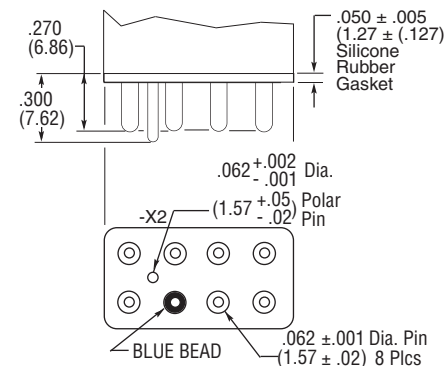

CODE "B" Circuit Board Pins - All DC Coils

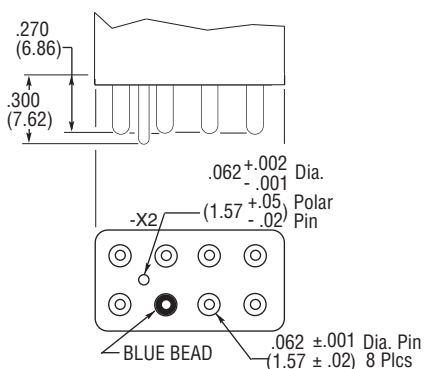

CODE "C" Solder Hook Terminals

HOOK TERMINALS TIN/LEAD PLATED

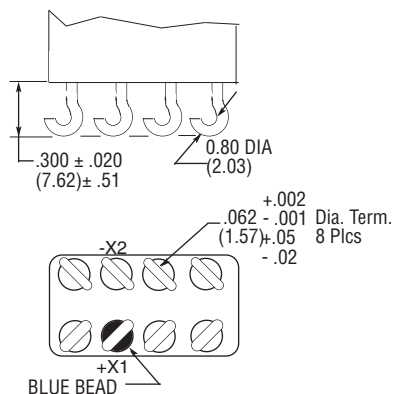

CODE "D" Socket Pins 115 VAC

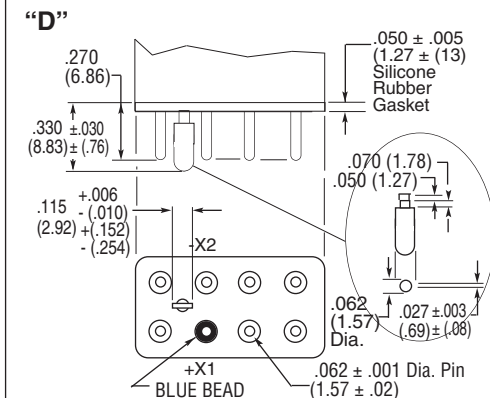

CODE "E" Socket Pins 28 VAC Coils

Same as Code "D" Except polarizing Pin turned 90° to this plane.

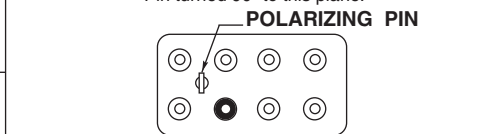

CODE "F" Circuit Board Pins 115 VAC Coils

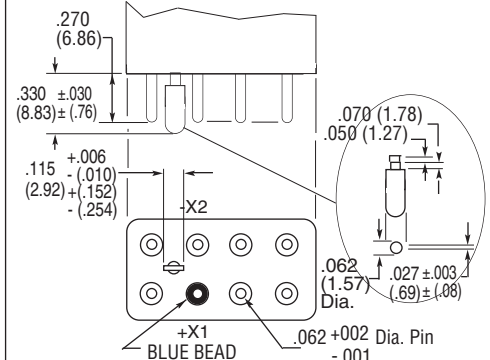

CODE "G" Circuit Board Pins 28 VAC Coils

Same as Code "F" Except polarizing Pin turned 90° to this plane.

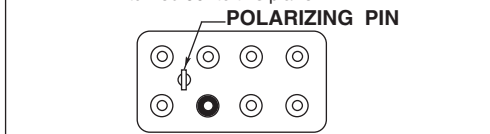

CODE "H" 90° Solder Pins

All Pins Bright Acid Tin/lead

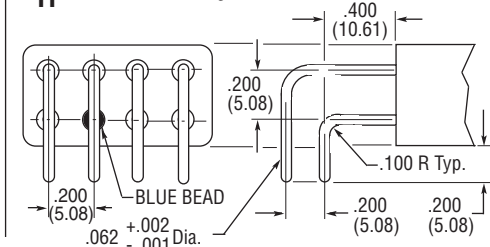

Enclosures

All Enclosures have Cupro-Nickel Cans bright acid tin/lead plated after assembly to terminal headers.

Dimensions: Inches ± .010 (mm ± .25)

"A" AC Coils 1.125 in. (28.57) Max.
DC Coils 1.010 in. (25.65) Max.

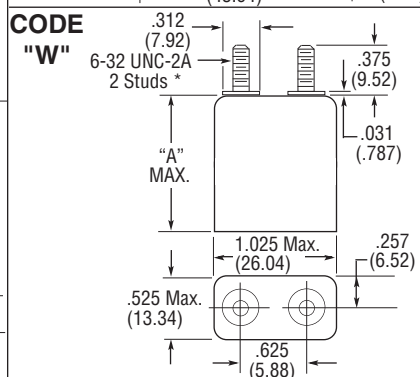
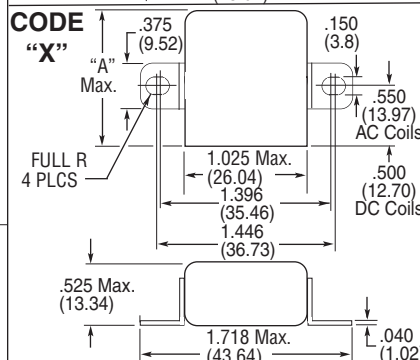
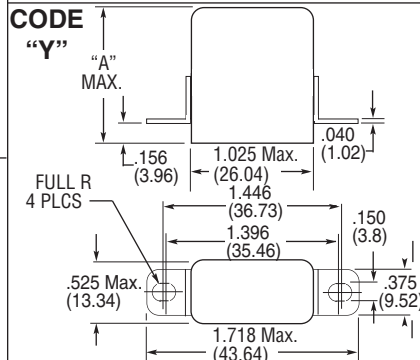
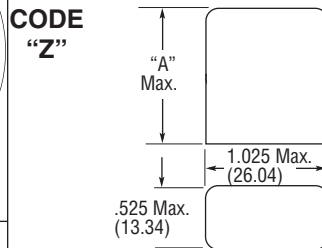

*Metric threads available. To specify use [M] in place of [W]

5 CII Mid-Range Relays

FCA-210 Series, 10 Amperes, DPDT (Continued)

Terminal Wiring

DC Coils with Transient Suppression

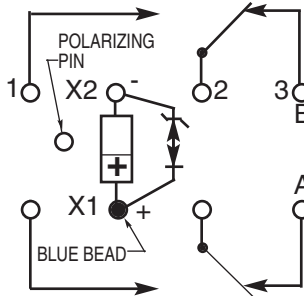

DC Coils

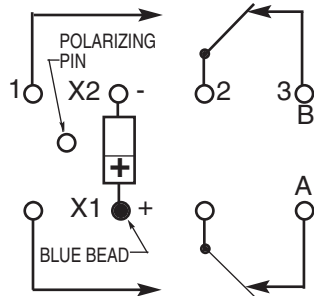

AC Coils 115 VAC

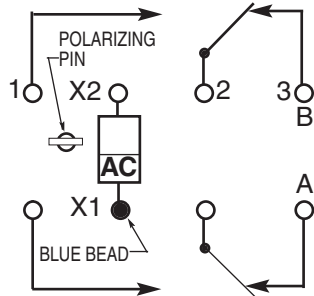

AC Coils 28 VAC

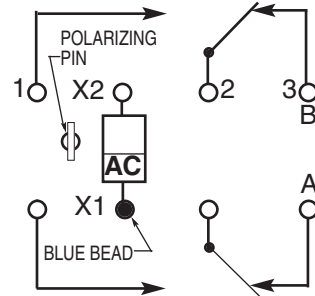

NOTE: Polarity must be observed with DC coil supply. Relay is polarized with a permanent magnet and will not operate or be damaged by reverse polarity.

Diodes used in transient suppression and in AC rectifier circuits have peak inverse voltage rating of 600 VDC minimum. Zener diodes have a minimum rating of 1 watt.

Terminal designations are for reference only and do not appear on the header.

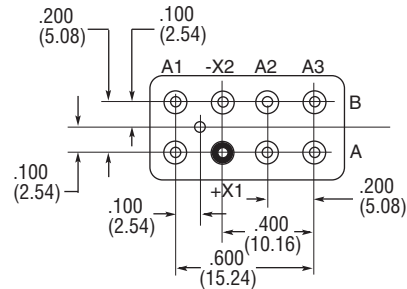

TERMINAL VIEW

HOW TO ORDER

**FCA-215-
FCA-210-A Y 4**

RELAY TYPE _____

TERMINALS (Socket Pins, DC Coil) _____

ENCLOSURE (With Flanges) _____

COIL (28 VDC With Transient Suppression). _____

NOTE: Only DC coil models are QPL Approved

* The part number example shown on this page is for catalog items. For a list of specific QPL part numbers, please see the index in Section 15.

FCA-212 Series, 12 Amperes, DPDT



The Series FCA-212 relay is a polarized single-side stable design, where the flux from a permanent magnet provides the armature holding force in the deactivated state, and its flux path is switched and combined with the coil flux in the operated state. This

results in appreciably increased contact pressure in both states over that of a spring return nonpolar design. We also manufacture other versions of this relay:

FCA-412 — 12 Amp 4PDT Relay

General Specifications

- Temperature Rating** — -70°C TO + 125°C
- Altitude** — 300,000 Feet
- Shock*** — Z, Y, & X Enclosures — 200 g for 6 mS
W & M Enclosures (Stud Mtg.) — 100 g for 6 mS
- Vibration, Sinusoidal*** — Z, Y, & X Enclosures — 30 g 33-3000Hz
W Enclosure — 20 g 33-3000Hz
- Vibration, Random*** — Z, Y, & X Enclosures — 0.4 g²/Hz 50-2000Hz
W & M Enclosures (Stud Mtg.) — 0.2 g²/Hz 50-2000Hz
- Dielectric Strength** — At Sea Level — All circuits to ground and circuit to circuit — 1250 V rms
Coil to ground — 1000 V rms
At 80,000 Feet — 350 V rms
- Insulation Resistance** — Initial (500 VDC) — 100 MΩ Min.
After Life or Environmental Tests — 50 MΩ Min.
- Operate Time at Nominal Voltage** — DC Relays — 10 ms or less
AC Relays — 15 ms or less
- Release Time at Nominal Voltage** — DC Relays — 10 ms or less
AC Relays — 50 ms or less

Product Facts

- Hermetically Sealed
- All Welded Construction
- Balanced Force
- Permanent Magnet Drive
- Contacts — Silver Cadmium Oxide with Gold Plating
- Coils for DC, 50 to 400Hz and 400Hz AC
- Weight 1.6 ounces max. (45.4 grams)

Contact Rating — Amperes Ratings Are Continuous Duty

Type of Load	Life (Min.) Cycles x 10 ³	28 VDC	115VAC 400Hz	115/200VAC 3Ø	
				400Hz	60Hz*
Resistive	100	12	12	12	2.5
Inductive	20	8	8	8	2.5
Motor	100	4	4	4	2.0
Lamp	100	2	2	2	1

*60 Hz loads rated for 10,000 operations

- Overload Current** — 40 AMPS DC, 60 AMPS 400Hz
- Rupture Current** — 50 AMPS DC, 80 AMPS 400Hz
- Contact Make Bounce** — 1 MILLISECOND AT NOMINAL VOLTAGE
- Max. Contact Drop at 12 Amps** — INITIAL 0.150 VOLTS
- End of Life** — 0.175 VOLTS

* Max. contact opening under vibration or shock 10 microseconds

Coil Data

Coil Code	Nominal Voltages	Freq. Hz	DC Res. AC Amps (B)	Over Temperature Range		
				Pickup or Below Volts	Dropout or Above Volts	Must Hold Voltage (C)
1	6	DC	20 Ω	4.5	0.3	2.5
2	12	DC	80 Ω	9.0	0.75	4.5
3	28	DC	320 Ω	18.0	1.5	7.0
4 (A)	28	DC	320 Ω	18.0	1.5	7.0
5	48	DC	920 Ω	32.0	2.5	14.0
6	28	400Hz	180 mA	22.0	1.25	10.0
7	28	50/400Hz	100 mA	22.0	1.25	10.0
8	115	400 Hz	40 mA	90.0	5.0	40.0
9	115	50/400 Hz	30 mA	95.0	5.0	40.0

- A. CODE 4 COILS HAVE BACK EMF SUPPRESSION TO 42 VOLTS MAX.
- B. DC COIL RESISTANCE ± 10% AT 25°C; AC COIL MAX. CURRENT AT NOMINAL VOLTAGE.
- C. RELAY WILL STAY IN PICKED-UP STATE DOWN TO MUST HOLD VOLTAGES SHOWN.
- D. MAX. OVERVOLTAGE: 6 & 12 VDC COILS 120% OF NOMINAL; ALL OTHERS 110% OF NOMINAL.
- E. COILS AVAILABLE FOR OTHER VOLTAGES AND FOR AC 50/60HZ.

FCA-212 Series, 12 Amperes, DPDT (Continued)

Below are shown the standard terminal types and the enclosures available. Specify the assembly as indicated under How To Order. Dimensions are shown in inches ± .010 and (Millimeters ± .25).

Terminals

SOCKET PINS ARE GOLD PLATED
POLARIZING PINS ARE TIN/LEAD PLATED
CIRCUIT BOARD PINS ARE TIN/LEAD PLATED
DIMENSIONS EXCEPT AS NOTED:
INCHES ± .010 (MILLIMETERS ± .25)

CODE "A" Socket Pins - All DC Coils

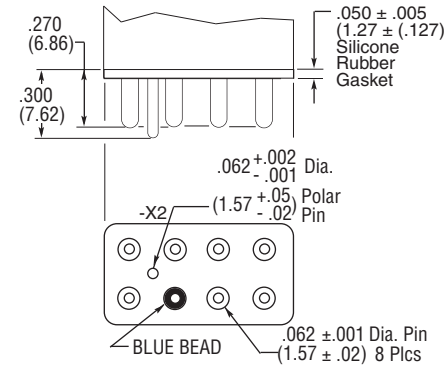

CODE "B" Circuit Board Pins - All DC Coils

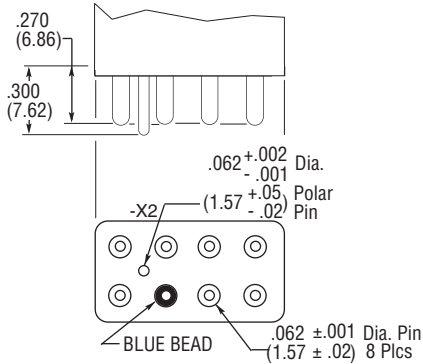

CODE "C" Solder Hook Terminals
HOOK TERMINALS TIN/LEAD PLATED

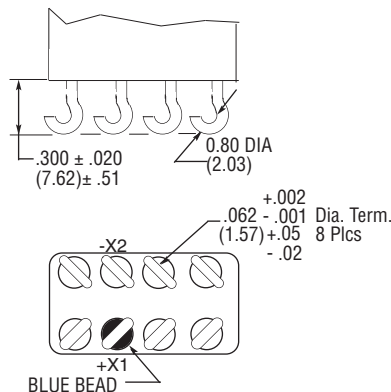

CODE "D" Socket Pins 115 VAC

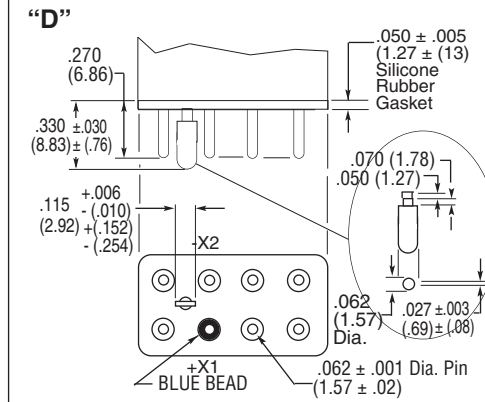

CODE "E" Socket Pins 28 VAC Coils

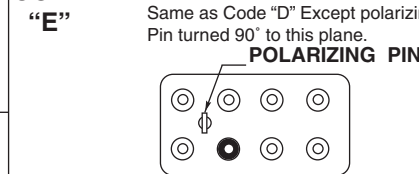

CODE "F" Circuit Board Pins 115 VAC Coils

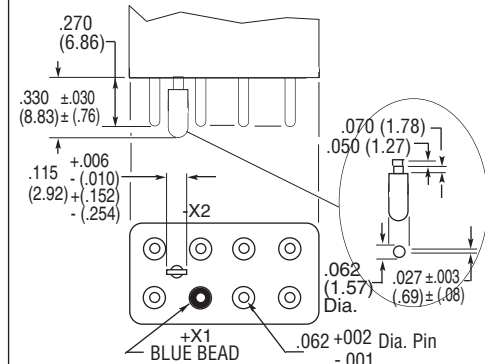

CODE "G" Circuit Board Pins 28 VAC Coils

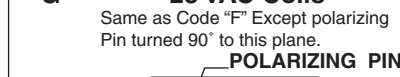

CODE "H" 90° Solder Pins

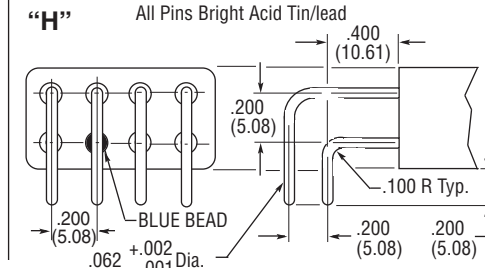

Enclosures

All Enclosures have Cupro-Nickel Cans bright acid tin/lead plated after assembly to terminal headers.

Dimensions: Inches ± .010 (mm ± .25)

"A" AC Coils 1.125 in. (28.57) Max.
DC Coils 1.010 in. (25.65) Max.

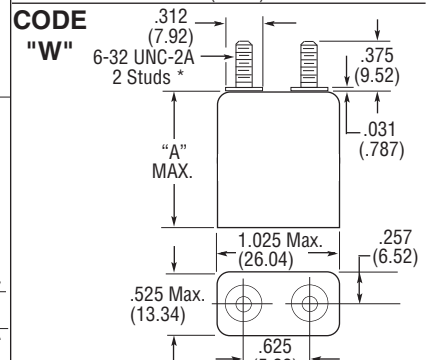
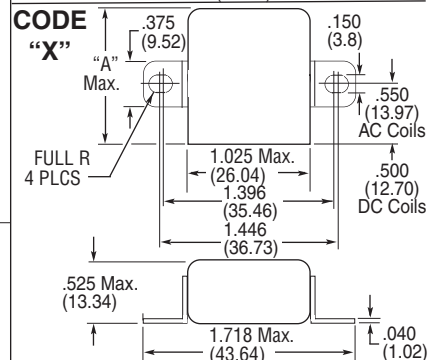
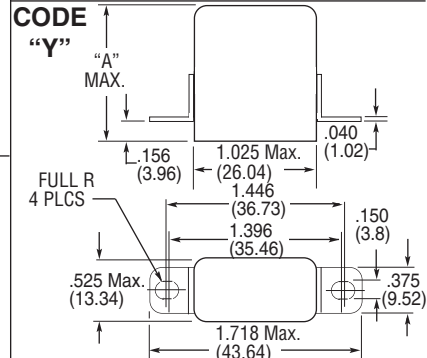
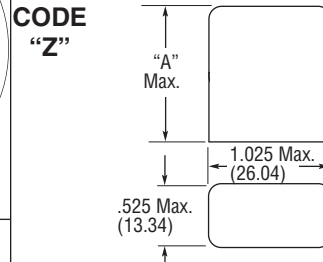

*Metric threads available. To specify use [M] in place of [W]

FCA-212 Series, 12 Amperes, DPDT (Continued)

Terminal Wiring

DC Coils with Transient Suppression

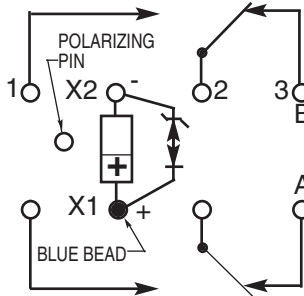

DC Coils

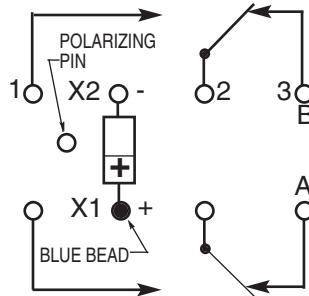

AC Coils 115 VAC

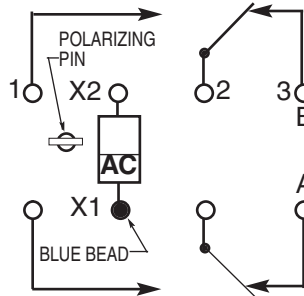

AC Coils 28 VAC

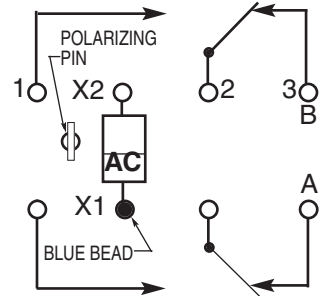

NOTE: Polarity must be observed with DC coil supply. Relay is polarized with a permanent magnet and will not operate or be damaged by reverse polarity.

Diodes used in transient suppression and in AC rectifier circuits have peak inverse voltage rating of 600 VDC minimum. Zener diodes have a minimum rating of 1 watt.

Terminal designations are for reference only and do not appear on the header.

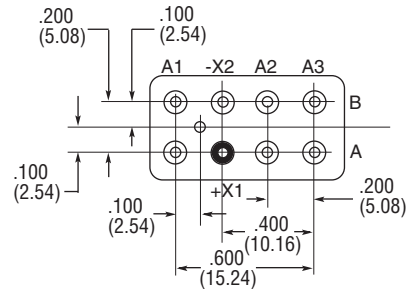

TERMINAL VIEW

HOW TO ORDER

FCA-212-A Y 4

RELAY TYPE _____

TERMINALS (Socket Pins, DC Coil) _____

ENCLOSURE (With Flanges) _____

COIL (28 VDC With Transient Suppression). _____

FCA-410 Series, 10 Amperes, 4PDT



Product Facts

- Hermetically Sealed
- All Welded Construction
- Balanced Force
- Permanent Magnet Drive
- 4PDT switching in one inch cube
- Contacts — Silver Cadmium Oxide with Gold Plating
- Coils for DC and AC 50 to 400Hz or 400Hz
- Weight 2.72 ounces max. (77 grams max.)
- Qualified to M83536/15, /16

The Series FCA-410 relay is a polarized single-side stable design, where the flux from a permanent magnet provides the armature holding force in the deactivated state, and its flux path is switched on the operated state. This results in appreciably increased contact pressure in both states over that of a spring return nonpolar

design. We also manufacture 2-pole and 6-pole versions of this relay.

FCA-210 — 10 Amp DPDT Relay

FCA-610 — 10 Amp 6PDT Relay

Available

FCA-415 — 15 Amp 4PDT, Has the same specifications as the FCA-410 except is rated at 15 amps. (Commercial Only)

General Specifications

Temperature Rating — -70°C TO + 125°C

Altitude — 300,000 Feet

Shock* —

Z & Y Enclosures —

200 g for 6 mS

W, X & M Enclosures —

100 g for 6 mS

Vibration, Sinusoidal* —

Z & Y Enclosures —

0.12 DA 10 to 70Hz

30 g 70 to 3000Hz

W, X & M Enclosures —

0.12 DA 10 to 57Hz

20 g 57 to 3000Hz

Vibration, Random* —

Z & Y Enclosures —

0.4 g²/Hz 50-2000Hz

W, X & M Enclosures —

0.2 g²/Hz 50-2000Hz

Dielectric Strength —

At Sea Level —

All circuits to ground and circuit to circuit — 1250 V rms

Coil to ground — 1000 V rms

At 80,000 Feet — 350 V rms

Insulation Resistance —

Initial (500 VDC) — 100 MΩ Min.

After Life or Environmental Tests —

50 MΩ Min.

Operate Time at Nominal Voltage —

DC Relays — 15 ms or less

AC Relays — 20 ms or less

Release Time at Nominal Voltage —

DC Relays — 15 ms or less

AC Relays — 50 ms or less

* Max. contact opening under vibration or shock 10 microseconds

Contact Rating — Amperes Ratings Are Continuous Duty

Type of Load	Life (Min.) Cycles x 10 ³	28 VDC	120VAC 400Hz	120/200VAC	
				400Hz-3Ø	60Hz-3Ø*
Resistive	100	10	10	10	2.5
Inductive	20	8	8	8	2.5
Motor	100	4	4	4	2.0
Lamp	100	2	2	2	1.0

*60 Hz loads rated for 10,000 operations

Overload Current — 40 AMPS DC, 60 AMPS 400Hz

Rupture Current — 50 AMPS DC, 80 AMPS 400Hz

Contact Make Bounce — 1 MILLISECOND AT NOMINAL VOLTAGE

Max. Contact Drop at 10 Amps — INITIAL 0.100 VOLTS

End of Life — 0.125 VOLTS

Coil Data

Coil Code	Nominal Voltages	Freq. Hz	DC Res. AC Amps (B)	Over Temperature Range		
				Pickup or Below Volts	Dropout or Above Volts	Must Hold Voltage (C)
1	6	DC	18 Ω	4.5	0.3	2.5
2	12	DC	70 Ω	9.0	0.75	4.5
3	28	DC	290 Ω	18.0	1.5	7.0
4 (A)	28	DC	290 Ω	18.0	1.5	7.0
5	48	DC	865 Ω	32.0	2.5	14.0
6	28	400Hz	225 mA	22.0	1.25	10.0
7	28	50/400Hz	120 mA	22.0	1.25	10.0
8	115	400 Hz	40 mA	90.0	5.0	40.0
9	115	50/400 Hz	30 mA	95.0	5.0	40.0

A. CODE 4 COILS HAVE BACK EMF SUPPRESSION TO 42 VOLTS MAX.

B. DC COIL RESISTANCE ± 10% AT 25°C; AC COIL MAX. CURRENT AT NOMINAL VOLTAGE.

C. RELAY WILL STAY IN PICKED-UP STATE DOWN TO MUST HOLD VOLTAGES SHOWN.

D. MAX. OVER-VOLTAGE: 6 & 12 VDC COILS 120% OF NOMINAL; ALL OTHERS 110% OF NOMINAL.

E. COILS AVAILABLE FOR OTHER VOLTAGES AND FOR AC 50/60HZ.

NOTE: Only DC Coil Models are QPL Approved.

FCA-410 Series, 10 Amperes, 4PDT (Continued)

Below are shown the standard terminal types and the enclosures available. Note that the pin configuration for coil connections is determined by the coil supply voltage. Specify the assembly as indicated under How To Order. Dimensions are shown in inches $\pm .010$ and (Millimeters $\pm .25$) except as noted.

Terminals

Terminals on 0.200 centers.
Coil terminals: X1-X2.
Socket Pins are Gold Plated.
Circuit Board Pins are Tin/Lead Plated.

CODE "A"
Socket Pins-All DC Coils

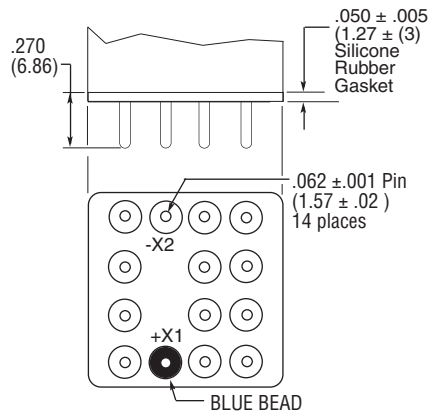

CODE "B"
Circuit Board Pins-All DC Coils

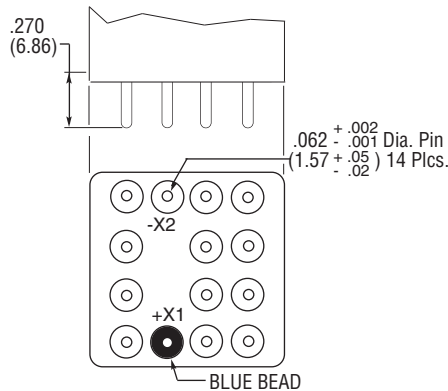

CODE "C"
Solder Hooks-AC or DC Coils

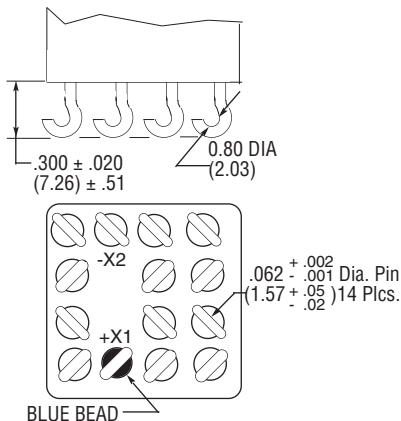

CODE "D"
Socket Pins-115 VAC Coils

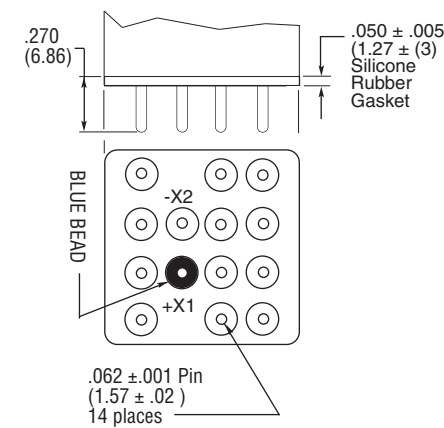

Enclosures

All Enclosures have cupro-Nickel cans bright acid tin/lead plated after assembly to terminal headers.

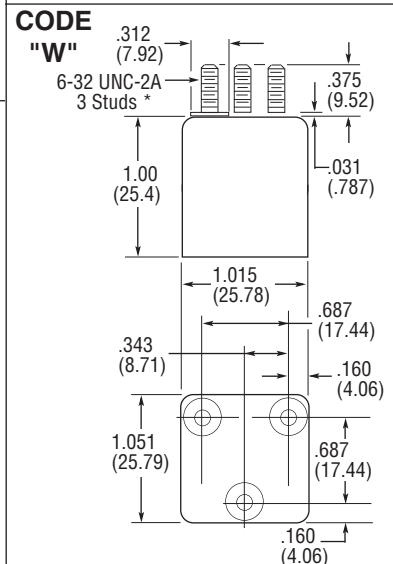
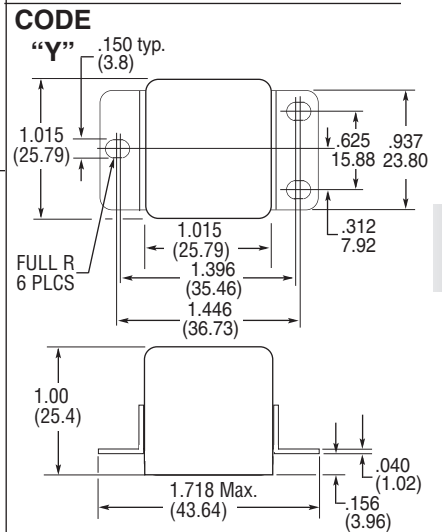
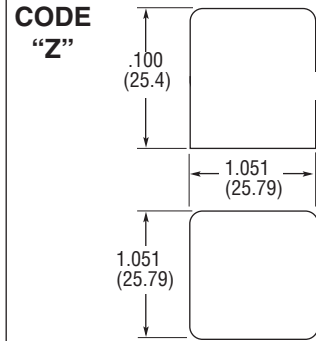

SEE NEXT PAGE
FOR MORE COIL
TERMINAL OPTIONS

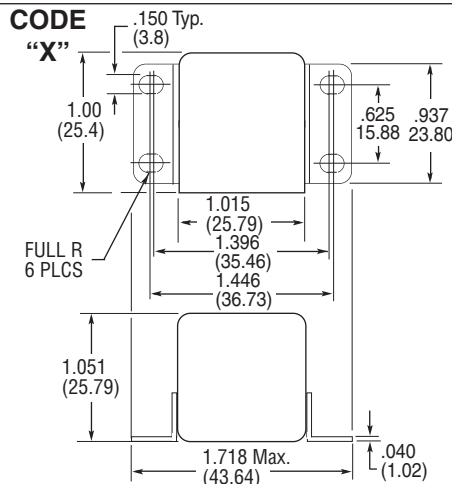

*Metric threads available, To specify use **M** in place of **W**

FCA-410 Series, 10 Amperes, 4PDT (Continued)

Terminals (Continued)

CODE "E"

Socket Pins- 28 VAC Coils

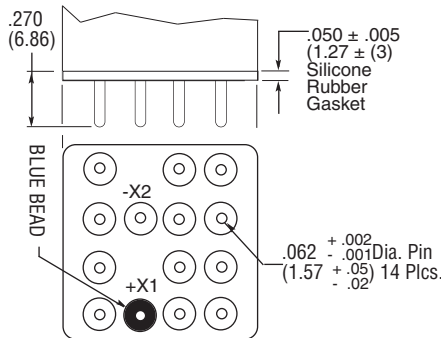

CODE "F"

Circuit Board Pins-115 VAC Coils

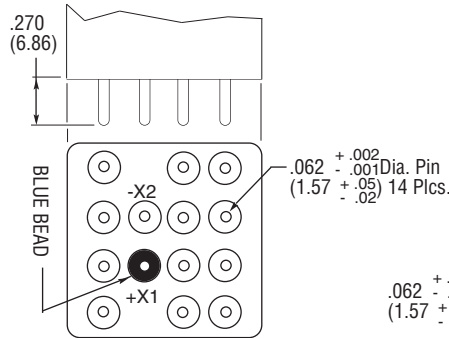

CODE "G"

Circuit Board Pins- 28 VAC Coils

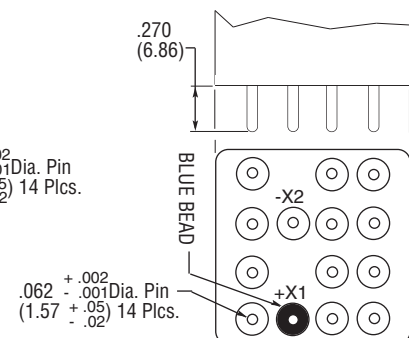

Terminal Wiring

A & B Pin Terminal
All DC Coils

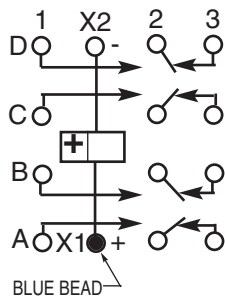

C Hook Terminal
All AC & DC Coils

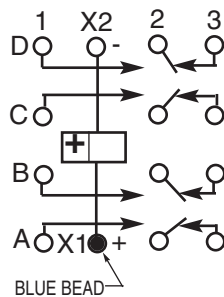

Transient Suppression
Cir.

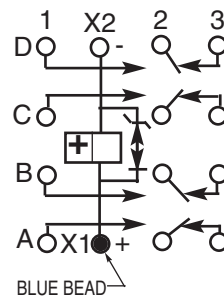

D & F Pin Terminal
115 VAC Coils

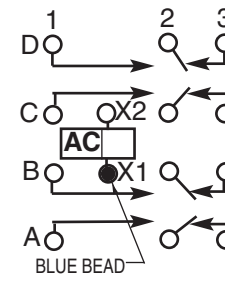

E & G Pin Terminal
28 VAC Coils

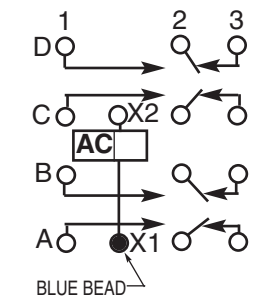

NOTE: Polarity must be observed with DC coil supply. Relay is polarized with a permanent magnet and will not operate or be damaged by reverse polarity.

Diodes used in transient suppression and in AC rectifier circuits have peak inverse voltage rating of 600 VDC minimum. Zener diodes have a minimum rating of 1 watt.

Terminal designations are for reference only and do not appear on the header.

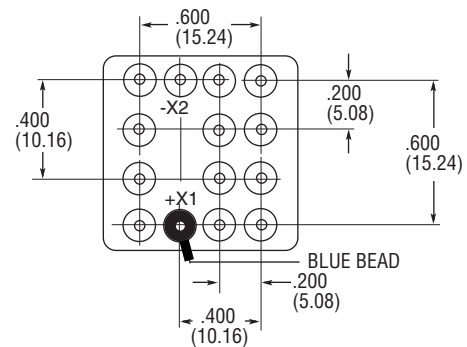

TERMINAL VIEW

**FCA-415-
FCA-410 A Y 4**

HOW TO ORDER

RELAY TYPE _____

TERMINALS (Socket Pins) _____

ENCLOSURE (With Flanges) _____

COIL (28 VDC With Transient Suppression). _____

NOTE: Only DC coil models are QPL Approved

* The part number example shown on this page is for catalog items. For a list of specific QPL part numbers, please see the index in Section 15.

FCA-125 Series, 25 Amperes, SPDT



Product Facts

- Hermetically Sealed
- All Welded Construction
- Balanced Force
- Permanent Magnet Drive
- Contacts — Silver Cadmium Oxide with Gold Plating
- Coils for DC, 50 to 400Hz and 400Hz AC
- Weight 1.6 ounces max. (45.4 grams)
- Qualified to M6106/19, M83536/36, /37

The Series FCA-125 relay is a polarized single-side stable design, where the flux from a permanent magnet provides the armature holding force in the deactivated state, and its flux path is switched and combined with the coil flux in the operated state.

This results in appreciably increased contact pressure in both states over that of a spring return nonpolar design. We also manufacture other versions of this relay:

FCA-325 — 25 Ampere 3PDT Relay

FCAC-325 — 25 Ampere 3PST-NO Relay with 2 amp SPDT auxiliary

General Specifications

- Temperature Rating** — -70°C TO + 125°C
- Altitude** — 300,000 Feet
- Shock*** — Z, Y, & X Enclosures — 200 g for 6 mS
W & M Enclosures (Stud Mtg.) — 100 g for 6 mS
- Vibration, Sinusoidal*** — Z, Y, & X Enclosures — 30 g 33-3000Hz
W & M Enclosures (Stud Mtg.) — 20 g 33-3000Hz
- Vibration, Random*** — Z, Y, & X Enclosures — 0.4 g²/Hz 50-2000Hz
W & M Enclosures (Stud Mtg.) — 0.2 g²/Hz 50-2000Hz
- Dielectric Strength** — At Sea Level — All circuits to ground and circuit to circuit — 1250 V rms
Coil to ground — 1000 V rms
At 80,000 Feet — 350 V rms
- Insulation Resistance** — Initial (500 VDC) — 100 MΩ Min.
After Life or Environmental Tests — 50 MΩ Min.
- Operate Time at Nominal Voltage** — DC Relays — 10 ms or less
AC Relays — 15 ms or less
- Release Time at Nominal Voltage** — DC Relays — 10 ms or less
AC Relays — 50 ms or less

Contact Rating — Amperes Ratings Are Continuous Duty

Type of Load	Life (Min.) Cycles x 10 ³	28 VDC	115VAC 400Hz	115VAC 60Hz*
Resistive	50	25	25	10
Inductive	10	12	—	10
Inductive	20	—	15	—
Motor	50	10	10	8
Lamp	50	5	5	—

*60 Hz loads rated for 10,000 operations

- Overload Current** — 50 AMPS DC, 80 AMPS 400Hz
- Rupture Current** — 60 AMPS DC, 100 AMPS 400Hz
- Contact Make Bounce** — 1 MILLISECOND AT NOMINAL VOLTAGE
- Max. Contact Drop at 25 Amps** — INITIAL 0.150 VOLTS
- End of Life** — 0.175 VOLTS

* Max. contact opening under vibration or shock 10 microseconds

Coil Data

Coil Code	Nominal Voltages	Freq. Hz	DC Res. AC Amps (B)	Over Temperature Range		
				Pickup or Below Volts	Dropout or Above Volts	Must Hold Voltage (C)
1	6	DC	20 Ω	4.5	0.3	2.5
2	12	DC	80 Ω	9.0	0.75	4.5
3	28	DC	320 Ω	18.0	1.5	7.0
4 (A)	28	DC	320 Ω	18.0	1.5	7.0
5	48	DC	920 Ω	32.0	2.5	14.0
6	28	400Hz	180 mA	22.0	1.25	10.0
7	28	50/400Hz	100 mA	22.0	1.25	10.0
8	115	400 Hz	40 mA	90.0	5.0	40.0
9	115	50/400 Hz	30 mA	95.0	5.0	40.0

- A. CODE 4 COILS HAVE BACK EMF SUPPRESSION TO 42 VOLTS MAX.
- B. DC COIL RESISTANCE ± 10% AT 25°C; AC COIL MAX. CURRENT AT NOMINAL VOLTAGE.
- C. RELAY WILL STAY IN PICKED-UP STATE DOWN TO MUST HOLD VOLTAGES SHOWN.
- D. MAX. OVERVOLTAGE: 6 & 12 VDC COILS 120% OF NOMINAL; ALL OTHERS 110% OF NOMINAL.
- E. COILS AVAILABLE FOR OTHER VOLTAGES AND FOR AC 50/60HZ.

NOTE: Only DC Coil Models are QPL Approved.

FCA-125 Series, 25 Amperes, SPDT (Continued)

Below are shown the standard terminal types and the enclosures available. Specify the assembly as indicated under How To Order. Dimensions are shown in inches ± .010 and (Millimeters ± .25).

Terminals

CODE "A"

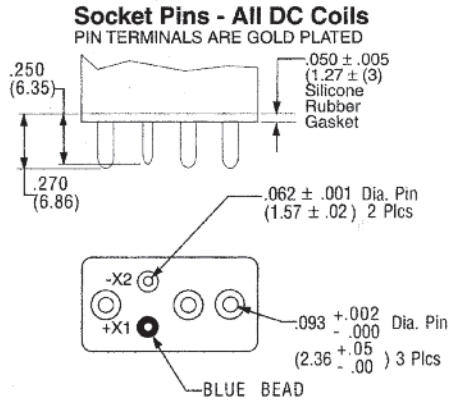

CODE "B"

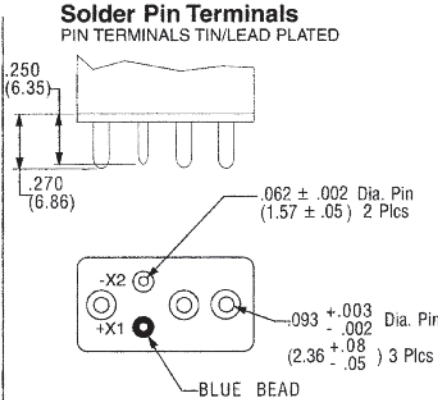

CODE "C"

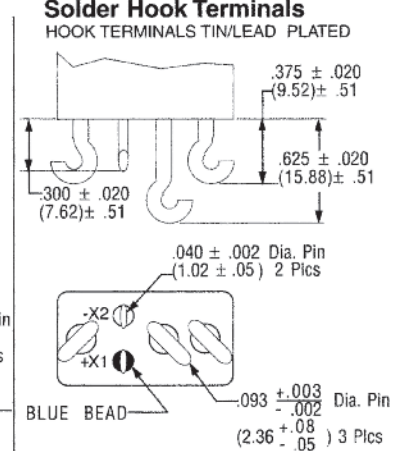

CODE "D"

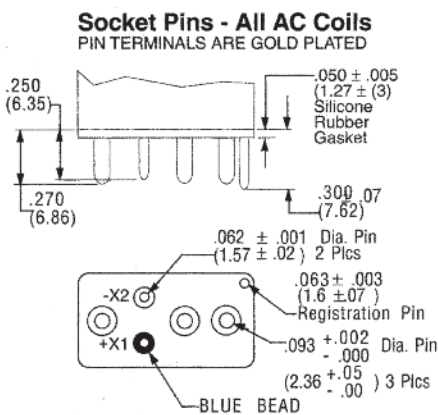

Enclosures

All Enclosures have cupro-Nickel cans bright acid tin/lead plated after assembly to terminal headers.

Dimensions: Inches ± .010 (mm ± .25)

"A" - AC Coils 1.125 in. (31.91) Max
DC Coils 1.010 in. (28.65) Max..

CODE "X"

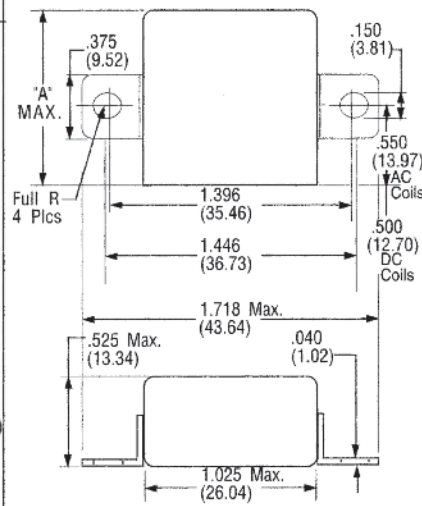

CODE "Z"

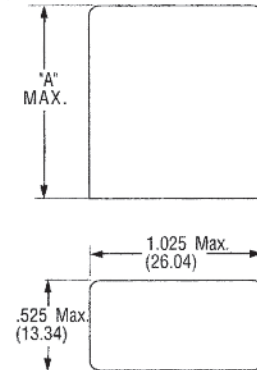

CODE "Y"

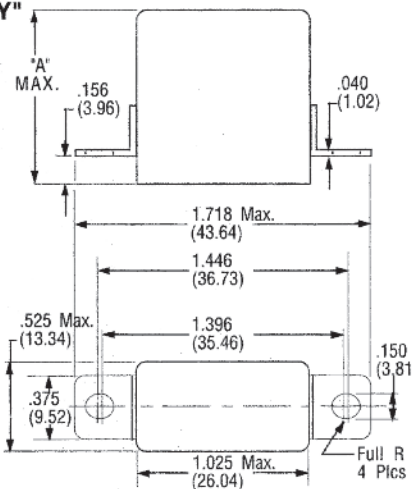

CODE "W"

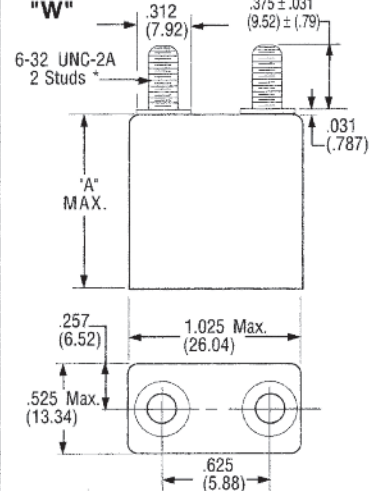

*Metric threads available. To specify use M in place of W

FCA-125 Series, 25 Amperes, SPDT (Continued)

Terminal Wiring

DC COILS

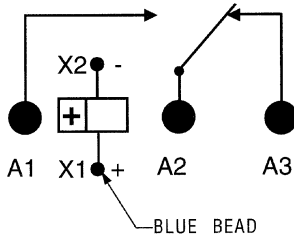

DC COILS WITH TRANSIENT SUPPRESSION

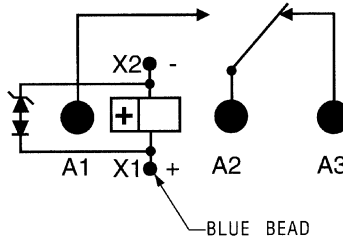

AC COILS

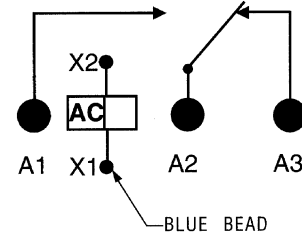

NOTE: Polarity must be observed with DC coil supply. Relay is polarized with a permanent magnet and will not operate or be damaged by reverse polarity.

Diodes used in transient suppression and in AC rectifier circuits have peak inverse voltage rating of 600 VDC minimum. Zener diodes have a minimum rating of 1 watt.

Terminal designations are for reference only and do not appear on the header.

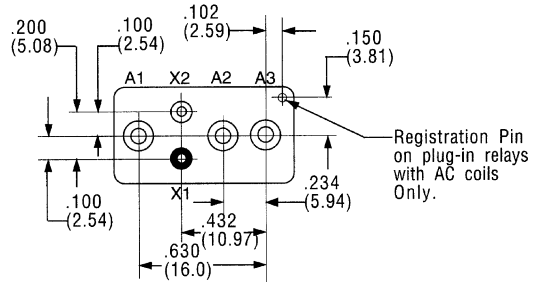

TERMINAL VIEW

HOW TO ORDER

FCA-125-A Y 4

RELAY TYPE _____

TERMINALS (Socket Pins, DC Coil) _____

ENCLOSURE (With Flanges) _____

COIL (28 VDC With Transient Suppression). _____

NOTE: Only DC coil models are QPL Approved

* The part number example shown on this page is for catalog items. For a list of specific QPL part numbers, please see the index in Section 15.

FCA-325 Series, 25 Amperes, 3PDT



Product Facts

- Hermetically Sealed
- All Welded Construction
- Balanced Force
- Permanent Magnet Drive
- Contacts — Silver Cadmium Oxide with Gold Plating
- Coils for DC, 50 to 400Hz and 400Hz AC
- Weight 2.89 ounces max. (82 grams)
- Qualified to M83536/32, /33

The Series FCA-325 relay is a polarized single-side stable design, where the flux from a permanent magnet provides the armature holding force in the deactivated state, and its flux path is switched when combined with the coil flux in the operated state.

This results in appreciably increased contact pressure in both states over that of a spring return nonpolar design. We also manufacture other versions of this relay:

FCA-125 — 25 Amp SPDT Relay

FCAC-325 — 25 Ampere 3PST-NO Relay with 2 amp SPDT auxiliary

General Specifications

- Temperature Rating** — -70°C TO + 125°C
- Altitude** — 300,000 Feet
- Shock*** — Z, Y, & V Enclosures — 200 g for 6 mS
W, X & M Enclosures — 100 g for 6 mS
- Vibration, Sinusoidal*** — Z, Y, & V Enclosures — 30 g 33-3000Hz
W, X & M Enclosures — 20 g 33-3000Hz
- Vibration, Random*** — Z, Y, & V Enclosures — 0.4 g²/Hz 50-2000Hz
W, X & M Enclosures — 0.2 g²/Hz 50-2000Hz
- Dielectric Strength** — At Sea Level — All circuits to ground and circuit to circuit — 1250 V rms
Coil to ground — 1000 V rms
At 80,000 Feet — 350 V rms
- Insulation Resistance** — Initial (500 VDC) — 100 MΩ Min.
After Life or Environmental Tests — 50 MΩ Min.
- Operate Time at Nominal Voltage** — DC Relays — 15 ms or less
AC Relays — 20 ms or less
- Release Time at Nominal Voltage** — DC Relays — 15 ms or less
AC Relays — 50 ms or less

Contact Rating — Amperes Ratings Are Continuous Duty

Type of Load	Life (Min.) Cycles x 10 ³	28 VDC	115VAC		
			400Hz	115/200VAC	
			400Hz-3Ø	60Hz-3Ø*	
Resistive	50	25	25	25	2.5
Inductive	10	12	—	—	2.5
Inductive	20	—	15	15	—
Motor	50	10	10	10	2.0
Lamp	50	5	5	5	1.0

*60 Hz loads rated for 10,000 operations

Overload Current — 50 AMPS DC, 80 AMPS 400Hz

Rupture Current — 60 AMPS DC, 100 AMPS 400Hz

Contact Make Bounce — 1 MILLISECOND AT NOMINAL VOLTAGE

Max. Contact Drop at 25 Amps — INITIAL 0.150 VOLTS

End of Life — 0.175 VOLTS

* Max. contact opening under vibration or shock 10 microseconds

Coil Data

Coil Code	Nominal Voltages	Freq. Hz	DC Res. AC Amps (B)	Over Temperature Range		
				Pickup or Below Volts	Dropout or Above Volts	Must Hold Voltage (C)
1	6	DC	18 Ω	4.5	0.3	2.5
2	12	DC	70 Ω	9.0	0.75	4.5
3	28	DC	290 Ω	18.0	1.5	7.0
4 (A)	28	DC	290 Ω	18.0	1.5	7.0
5	48	DC	865 Ω	32.0	2.5	14.0
6	28	400Hz	225 mA	22.0	1.25	10.0
7	28	50/400Hz	120 mA	22.0	1.25	10.0
8	115	400 Hz	40 mA	90.0	5.0	40.0
9	115	50/400 Hz	30 mA	95.0	5.0	40.0

A. CODE 4 COILS HAVE BACK EMF SUPPRESSION TO 42 VOLTS MAX.

B. DC COIL RESISTANCE ± 10% AT 25°C; AC COIL MAX. CURRENT AT NOMINAL VOLTAGE.

C. RELAY WILL STAY IN PICKED-UP STATE DOWN TO MUST HOLD VOLTAGES SHOWN.

D. MAX. OVER-VOLTAGE: 6 & 12 VDC COILS 120% OF NOMINAL; ALL OTHERS 110% OF NOMINAL.

E. COILS AVAILABLE FOR OTHER VOLTAGES AND FOR AC 50/60HZ.

NOTE: Only DC Coil Models are QPL Approved.

FCA-325 Series, 25 Amperes, 3PDT (Continued)

Below are shown the standard terminal types and the enclosures available. Specify the assembly as indicated under How To Order. Dimensions are shown in inches ± .010 and (Millimeters ± .25).

Terminals

CODE

"A" Socket Pins - All DC Coils

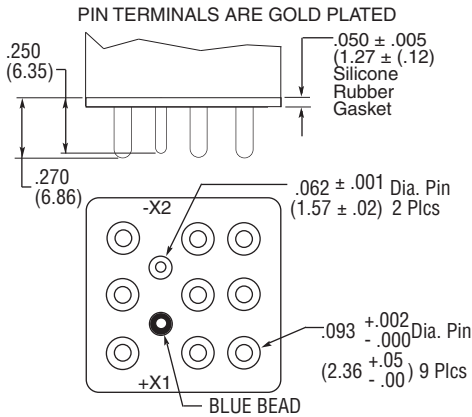

CODE

"B" Solder Pin Terminals

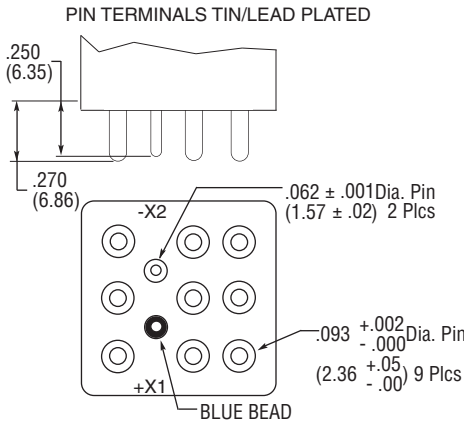

CODE

"C" Solder Hook Terminals

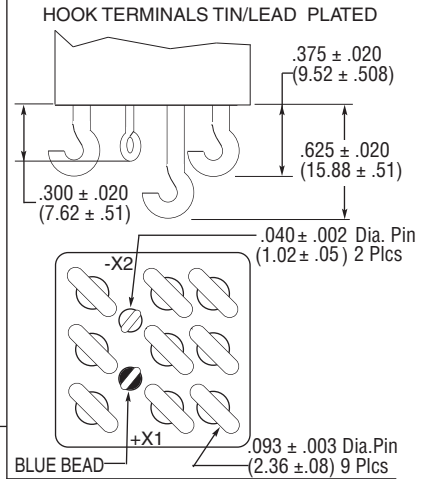

CODE

"V"

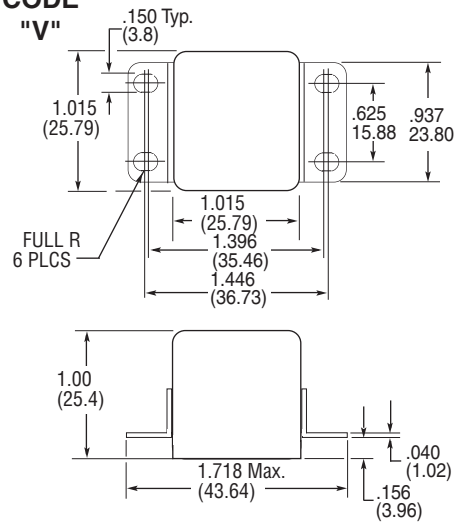

Enclosures

All Enclosures have cupro-Nickel cans bright acid tin/lead plated after assembly to terminal headers.

Dimensions: Inches ± .010 (mm ± .25)

For socket pin terminals: specify "Y" enclosures with DC coils and "V" enclosures with AC coils.

CODE

"Z"

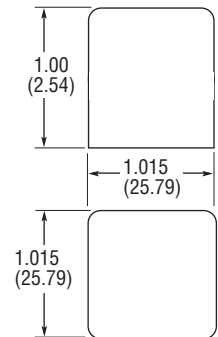

CODE

"Y"

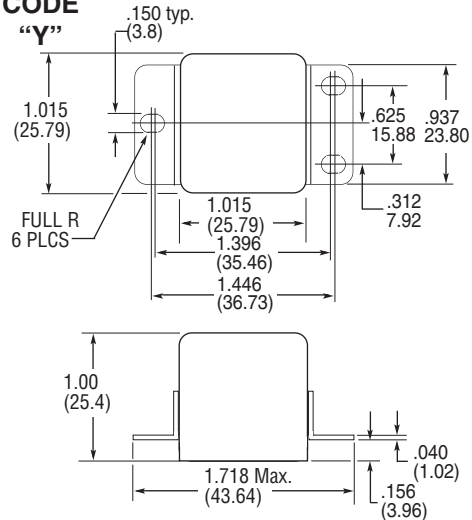

CODE

"X"

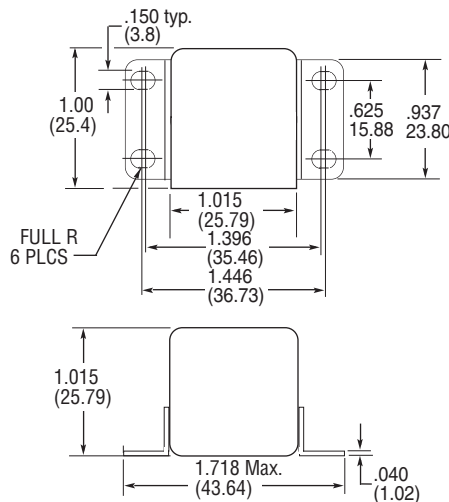

CODE

"W"

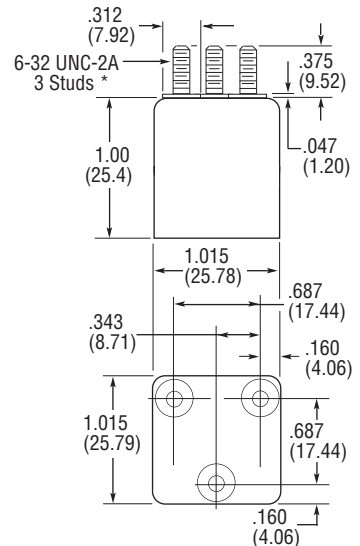

*Metric threads available, To specify use [M] in place of [W]

5 CII Mid-Range Relays

FCA-325 Series, 25 Amperes, 3PDT (Continued)

Terminal Wiring

DC Coils

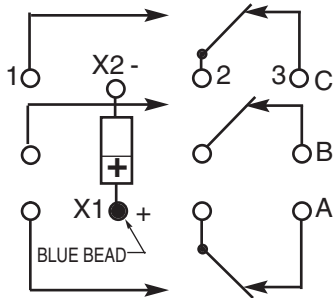

DC Coils with Transient Suppression

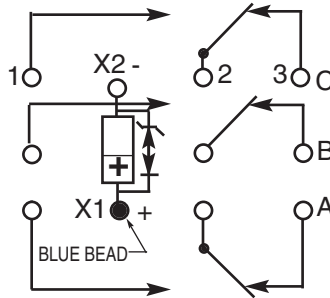

AC Coils

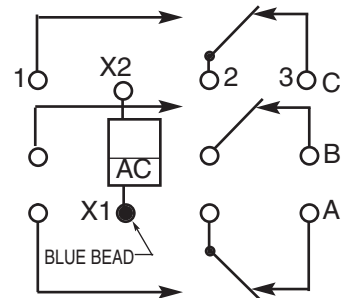

NOTE: Polarity must be observed with DC coil supply. Relay is polarized with a permanent magnet and will not operate or be damaged by reverse polarity.

Diodes used in transient suppression and in AC rectifier circuits have peak inverse voltage rating of 600 VDC minimum. Zener diodes have a minimum rating of 1 watt.

Terminal designations are for reference only and do not appear on the header.

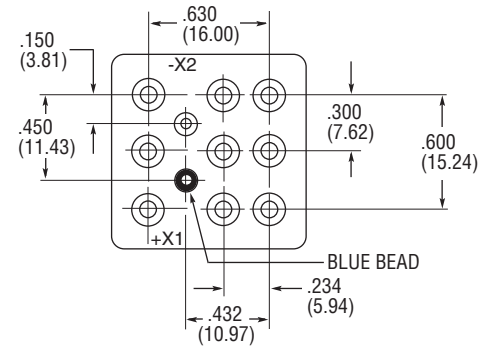

TERMINAL VIEW

HOW TO ORDER

FCA-325-A Y 4

RELAY TYPE _____

TERMINALS (Socket Pins, DC Coil) _____

ENCLOSURE (With Flanges) _____

COIL (28 VDC With Transient Suppression). _____

NOTE: Only DC coil models are QPL Approved

* The part number example shown on this page is for catalog items. For a list of specific QPL part numbers, please see the index in Section 15.

FCAC-325 Series, 25 Amperes, 3PST-NO with 2 Amp SPDT Auxiliary Contacts



Product Facts

- Hermetically Sealed
- All Welded Construction
- Balanced Force
- Permanent Magnet Drive
- Contacts — Silver Cadmium Oxide with Gold Plating
- Coils for DC, 50 to 400Hz and 400Hz AC
- Weight 2.89 ounces max. (82grams)

The Series FCAC-325 relay is a polarized single-side stable design, where the flux from a permanent magnet provides the armature holding force in the deactivated state, and its flux path is switched on the operated state. This results in appreciably increased contact pressure

in both states over that of a spring return nonpolar design. We also manufacture other versions of this relay:

FCA-125 — 25 Ampere SPDT Relay

FCA-325 — 25 Ampere 3PDT Relay

General Specifications

- Temperature Rating** — -70°C TO + 125°C
- Altitude** — 300,000 Feet
- Shock*** —
Z, Y, & V Enclosures — 200 g for 6 mS
W, X & M Enclosures — 100 g for 6 mS
- Vibration, Sinusoidal*** —
Z, Y, & V Enclosures — 30 g 33-3000Hz
W, X & M Enclosures — 20 g 33-3000Hz
- Vibration, Random*** —
Z, Y, & V Enclosures — 0.4 g²/Hz 50-2000Hz
W, X & M Enclosures — 0.2 g²/Hz 50-2000Hz
- Dielectric Strength** —
At Sea Level —
All circuits to ground and circuit to circuit — 1250 V rms
Coil to ground — 1000 V rms
At 80,000 Feet — 350 V rms
- Insulation Resistance** —
Initial (500 VDC) — 100 MΩ Min.
After Life or Environmental Tests — 50 MΩ Min.
- Operate Time at Nominal Voltage** —
DC Relays — 15 ms or less
AC Relays — 10 ms or less
- Release Time at Nominal Voltage** —
DC Relays — 15 ms or less
AC Relays — 50 ms or less

Contact Rating — Amperes Ratings Are Continuous Duty

Type of Load	Life (Min.) Cycles x10 ³	28 VDC		115VAC 400Hz		115/200VAC 400Hz-3Ø	115/200VAC 60Hz-3Ø*
		Main	Aux.	Main	Aux.		
Resistive	50	25	2	25	2	25	2.5
Inductive	10	12	1	—	—	—	2.5
Inductive	20	—	—	15	1	15	—
Motor	50	10	—	10	—	10	2.0
Lamp	50	5	.5	5	.5	.5	1.0

*60 Hz loads rated for 10,000 operations

- Overload Current** — 50 AMPS DC, 80 AMPS 400Hz
- Rupture Current** — 60 AMPS DC, 100 AMPS 400Hz
- Contact Make Bounce** — 1 MILLISECOND AT NOMINAL VOLTAGE
- Auxiliary Contact Bounce** — 4 MILLISECONDS MAX.
- Max. Contact Drop at 25 Amps** — INITIAL 0.150 VOLTS
- End of Life** — 0.175 VOLTS

* Max. contact opening under vibration or shock 10 microseconds

Coil Data

Coil Code	Nominal Voltages	Freq. Hz	DC Res. AC Amps (B)	Over Temperature Range		
				Pickup or Below Volts	Dropout or Above Volts	Must Hold Voltage (C)
1	6	DC	18 Ω	4.5	0.3	2.5
2	12	DC	70 Ω	9.0	0.75	4.5
3	28	DC	290 Ω	18.0	1.5	7.0
4 (A)	28	DC	290 Ω	18.0	1.5	7.0
5	48	DC	865 Ω	32.0	2.5	14.0
6	28	400Hz	225 mA	22.0	1.25	10.0
7	28	50/400Hz	120 mA	22.0	1.25	10.0
8	115	400 Hz	40 mA	90.0	5.0	40.0
9	115	50/400 Hz	30 mA	95.0	5.0	40.0

- A. CODE 4 COILS HAVE BACK EMF SUPPRESSION TO 42 VOLTS MAX.
- B. DC COIL RESISTANCE ± 10% AT 25°C; AC COIL MAX. CURRENT AT NOMINAL VOLTAGE.
- C. RELAY WILL STAY IN PICKED-UP STATE DOWN TO MUST HOLD VOLTAGES SHOWN.
- D. MAX. OVERVOLTAGE: 6 & 12 VDC COILS 120% OF NOMINAL; ALL OTHERS 110% OF NOMINAL.
- E. COILS AVAILABLE FOR OTHER VOLTAGES AND FOR AC 50/60HZ.

FCAC-325 Series (Continued)

Below are shown the standard terminal types and the enclosures available. Specify the assembly as indicated under How To Order. Dimensions are shown in inches ± .010 and (Millimeters ± .25).

Terminals

CODE "A"
Socket Pin Terminals
Pin Terminals are Gold Plated

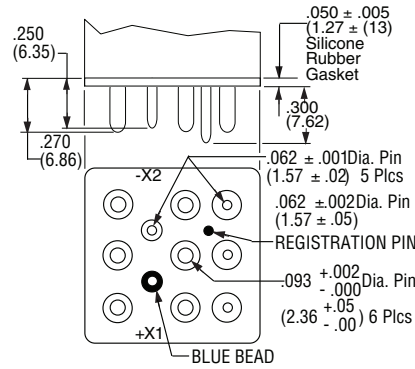

CODE "B"
Solder Pin Terminals
Pin Terminals are Tin/Lead Plated

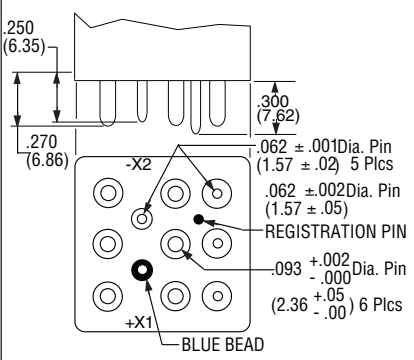

CODE "C"
Solder Hook Terminals
Hook Terminals are Tin/Lead Plated

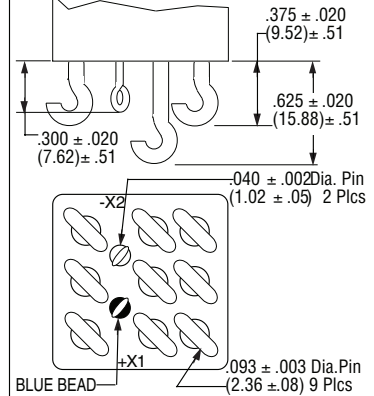

CODE "V"

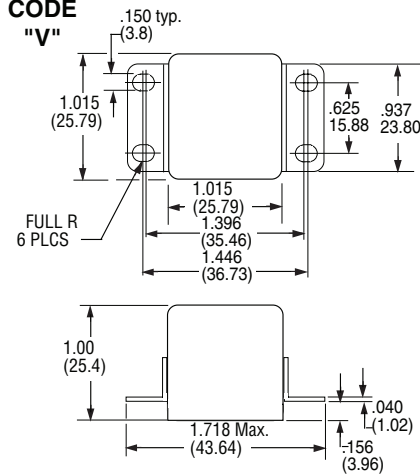

ENCLOSURES

All Enclosures have cupro-Nickel cans bright acid tin/lead plated after assembly to terminal headers.

Dimensions: Inches ± .010 (mm ± .25)

For socket pin terminals: specify "Y" enclosures with DC coils and "V" enclosures with AC coils.

CODE "Z"

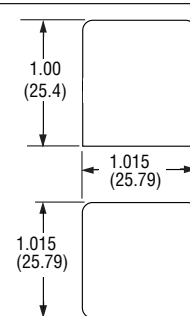

CODE "Y"

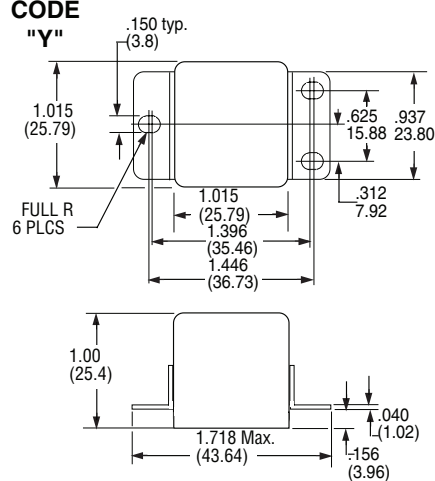

CODE "X"

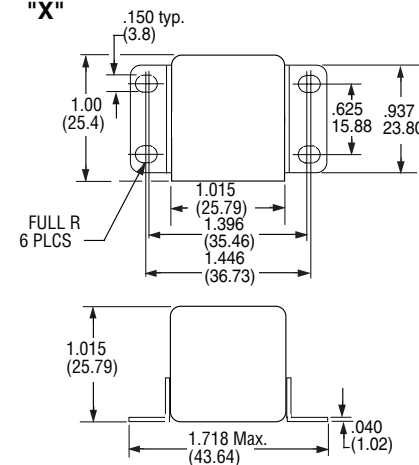

CODE "W"

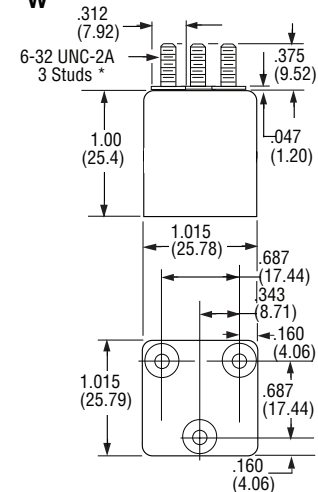

*Metric threads available, To specify use **M** in place of **UNC**

FCAC-325 Series (Continued)

Terminal Wiring

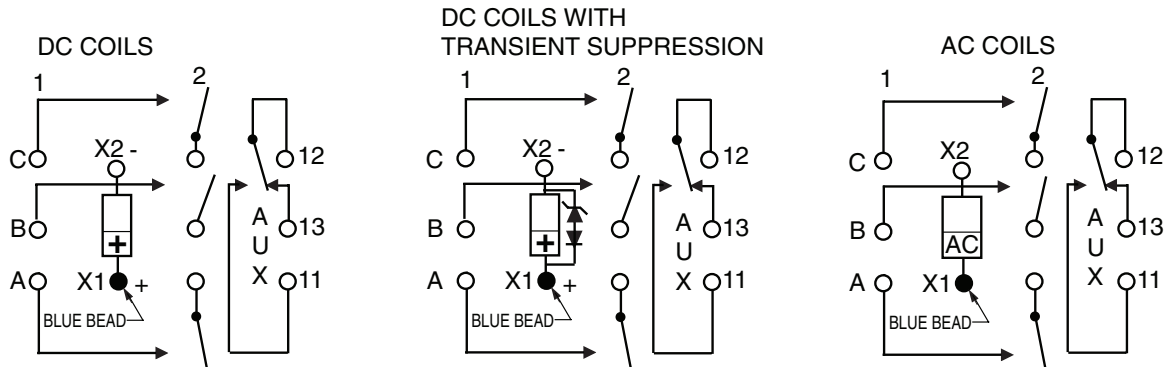

NOTE: Polarity must be observed with DC coil supply. Relay is polarized with a permanent magnet and will not operate or be damaged by reverse polarity.

Diodes used in transient suppression and in AC rectifier circuits have peak inverse voltage rating of 600 VDC minimum. Zener diodes have a minimum rating of 1 watt.

Terminal designations are for reference only and do not appear on the header.

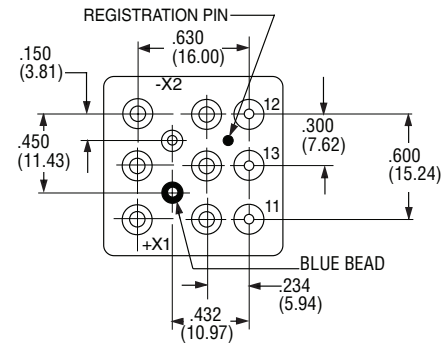

TERMINAL VIEW

HOW TO ORDER

FCAC-325 -A Y 4

RELAY TYPE _____

TERMINALS (Socket Pins, DC Coil) _____

ENCLOSURE (With Flanges and DC Coil) _____

COIL (28 VDC With Transient Suppression) _____

FCA-150 Series, 50 Amps, 1PST/NO (DM) Relay

Product Facts

- Non-latching relay
- Balanced force design
- Corrosion protected metal enclosure
- All welded hermetically sealed enclosure occupies about 1 in³ (16.4 cm³)
- 1 Form X (SPST-NO-DM)
- 6, 12 and 28 Vdc coils
- Weight: 90 grams
- Designed and built in accordance to MIL-PRF-6106

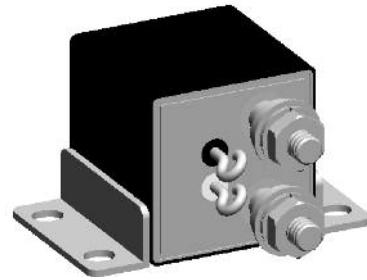
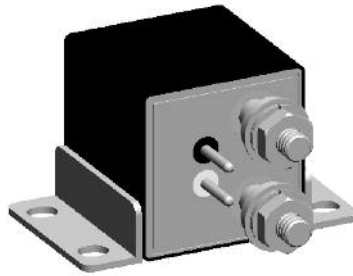

The FCA-150 series relay is a polarized, single-side stable design, where the flux from a permanent magnet provides the armature holding force in the deactivated state, and its flux path is switched and combined

with the coil flux in the operated state. This results in appreciably increased contact pressure in both states over that of a spring return non-polar design.

1 Form X (SPST-NO-DM) configuration with main contacts rated 50 Amps.

Specifications

Contact Data

Contact Form 1 Form X (SPST-NO-DM)

Contact Rating in Amps (Continuous Duty)

Type of Load	Life (Min.) Cycles	28 Vdc
Resistive	50,000	50
Inductive (L/R=5ms)	20,000	20
Motor	20,000	20
None	100,000	—

Overload Current (Resistive) 200 A, 50 cycles

Max. Contact Drop at 10A Initial 30mV; After Life 175mV

Operate Time at Nominal Voltage 15ms

Release Time 15ms

Bounce Time 1ms

Coil Data

Coil Code	1	2	3	4
Nominal Operating Voltage (Vdc)	6	12	28	28
Maximum Operating Voltage (Vdc)	7.3	14.5	29	29
Maximum Pick-Up Voltage at +125°C	4.5	9	18	18
Maximum Pick-Up Voltage at +125°C, continuous current test (Vdc)	5.7	11.25	22.5	22.5
Drop-Out Voltage at OTR	0.3 – 2.5	0.75 – 4.5	1.5 – 7.0	1.5 – 7.0
Maximum Coil Current at +25°C (A)	.50	.26	.15	.15
Back EMF Suppressed to (Vdc) (Max)	N/A	N/A	N/A	-42
Coil Resistance ±10%	18Ω	70Ω	290Ω	290Ω

FCA-150 Series, 50 Amps, 1PST/NO (DM) Relay (Continued)

Specifications

Electrical Data

Initial Insulation Resistance (note 1)	100 megohms, minimum, at 500Vdc, between each pin and case
Insulation Resistance After Life or Environmental Test (note 1)	50 megohms, minimum, at 500Vdc, between each pin and case
Dielectric Strength At Sea Level	
Contacts to Ground and Between Contacts	1,250Vrms, 60 Hz.
Coil to Ground	1,000Vrms, 60 Hz.
Dielectric Strength at 80,000 ft (25,000m), All Points (note 4)	
	500Vrms, 60 Hz

Environmental Data

Ambient Temperature Range, Operating	-70°C to +125°C
Altitude	300,000 feet
Shock Resistance	50 G's, 11 ms.
Vibration Resistance, Sinusoidal	20 G's, 75-3000Hz.

Mechanical Data

Approximate Weight	3.2 oz. (90g) Max.
--------------------	--------------------

NOTES

1. All wired terminals must be connected together during this test. Dielectric withstanding voltage and insulation resistance are measured between all mutually insulated wired terminals and between all these terminals and case.

Terminals

CODE "B"

Solder Pin Terminals
Tin/Lead Plated

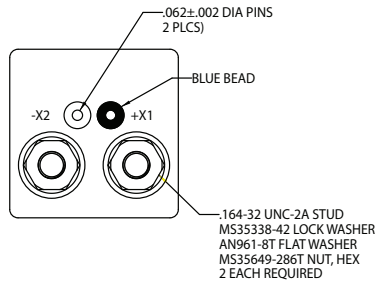
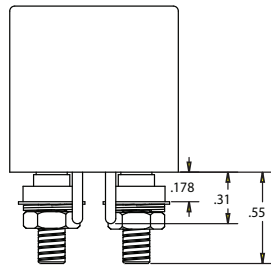

CODE "C"

Solder Hook Terminals
Tin/Lead Plated

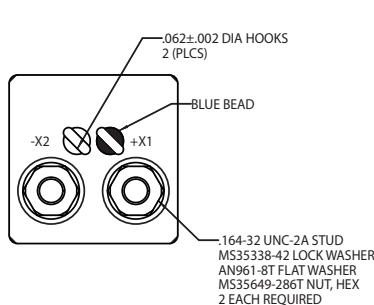
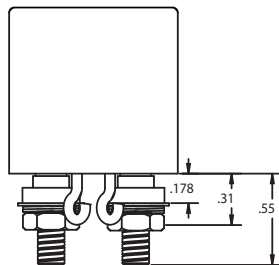

CODE "K"

Terminal Shield

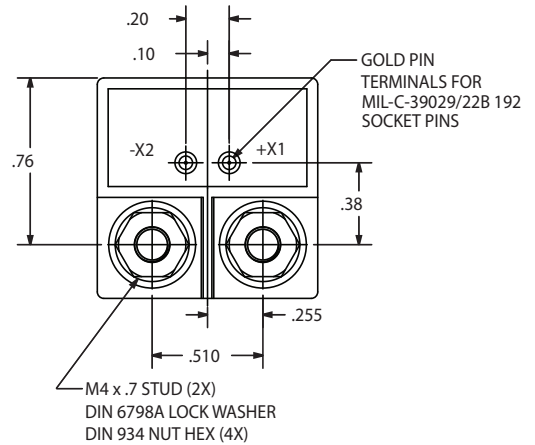

FCA-150 Series, 50 Amps, 1PST/NO (DM) Relay (Continued)

Outline Dimensions

The standard terminal types and enclosures are illustrated below with dimensions in inches ± 0.010 and (millimeters ± 0.25).

Enclosures

CODE "U"

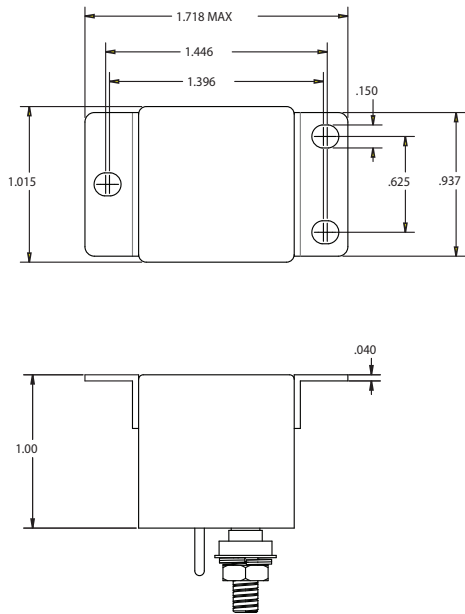

CODE "Y"

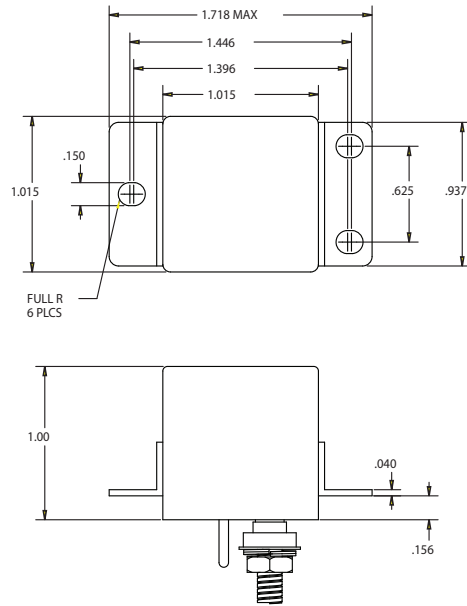

CODE "X"

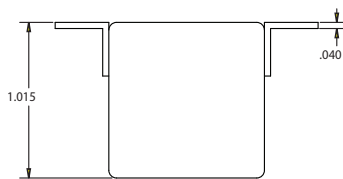

CODE "R"

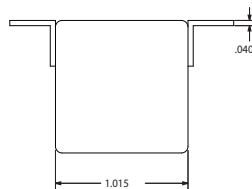

CODE "Z"

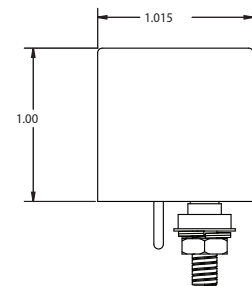
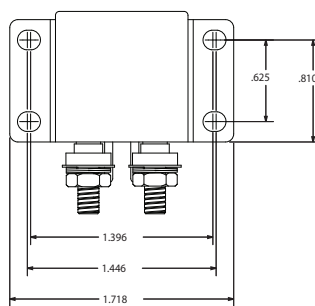
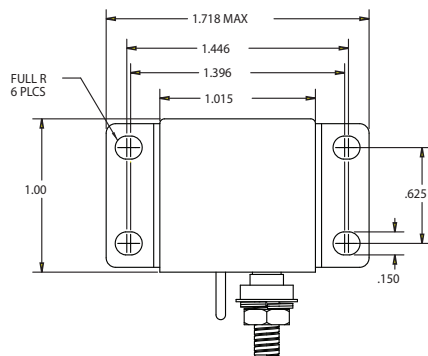
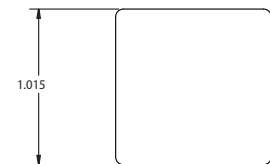

FCA-150 Series, 50 Amps, 1PST/NO (DM) Relay (Continued)

Terminal Wiring

DC Coils

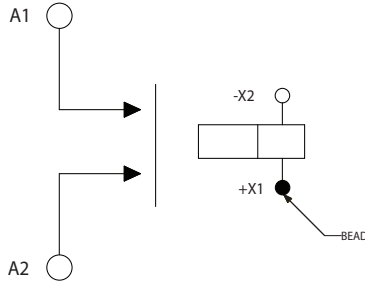

DC Coils with Transient Suppression

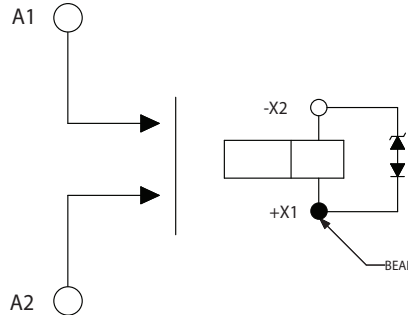

NOTE: Polarity must be observed with DC coil supply. Relay is polarized with a permanent magnet and will not operate or be damaged by reverse polarity.

Diodes used in transient suppression and in AC rectifier circuits have peak inverse voltage rating of 600 VDC minimum. Zener diodes have a minimum rating of 1 watt.

Terminal designations are for reference only and do not appear on the header.

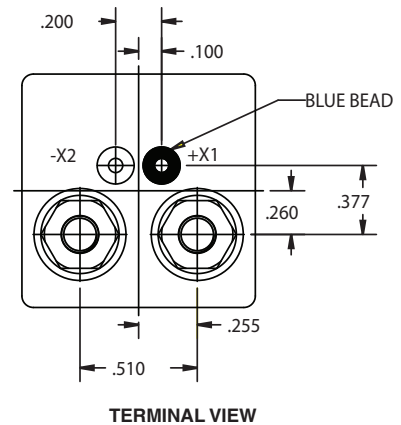

How to Order

Typical Part Number	FCA-150	-A	Y	3
Series and Contact Arrangement: FCA-150 = Relay with 1 Form X Main Contacts				
Terminals (see drawings for details): B = Solder Pin Coil Terminals, Stud Power Terminals C = Solder Hook Coil Terminals, Stud Power Terminals K = Terminal Block, Stud Power Terminals				
Enclosure (see drawings for details): R = Horizontal Flange Mount, Rotated U = Flush Vertical Flange Mount X = Horizontal Flange Mount Y = Raised Vertical Flange Mount Z = No Mount				
Coil: 1 = 6Vdc nominal 2 = 12Vdc nominal 3 = 28Vdc nominal 4 = 28Vdc nominal, with back EMF suppression				

5
CII Mid-Range Relays

FCA-150NC Series, 50 Amps, 1PST/NC (DB) Relay

Product Facts

- Non latching hermetically sealed relay
- Balanced force design
- Hermetically sealed, corrosion protected metal can
- All welded construction
- 6, 12 and 28Vdc coils available.
- Weight 90 grams
- Designed and built in accordance to MIL-PRF-6106

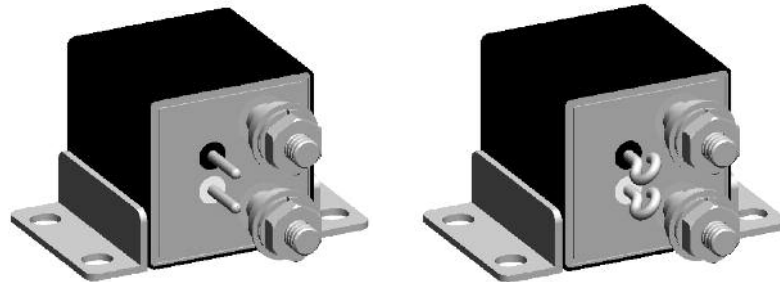

Specifications

General Characteristics

Temperature range	-70° C to +125° C
Altitude	300,000 feet
Dielectric strength at sea level	
- Contacts to ground and between contacts	1250 Vrms / 60 Hz
- Coil to ground	1000 Vrms / 60 Hz
Dielectric strength at altitude 25000 m (80,000 ft) (all points)	500 Vrms / 60 Hz
Initial insulation resistance at 500 Vdc	100 MΩ min.
Initial insulation after life or environmental test	50 MΩ min.
Sinusoidal vibration	20g / 75 to 3000 Hz
Shock	50g / 11 ms
Operate time at nominal voltage	15 ms max.
Release time	15 ms max.
Bounce time	1 ms max.
Contact voltage drop at nominal current	
-initial value	150 mV max.
-after life	175 mV max.

Coil Data

Coil Code	1	2	3	4(A)
Nominal Operating Voltage (Vdc)	6	12	28	28
Maximum Operating Voltage (Vdc)	7.3	14.5	29	29
Maximum Pick-Up Voltage at +125°C	4.5	9	18	18
Maximum Pick-Up Voltage at +125°C, continuous current test (Vdc)	5.7	11.25	22.5	22.5
Drop-Out Voltage at OTR	0.3 – 2.5	0.75 – 4.5	1.5 – 7.0	1.5 – 7.0
Maximum Coil Current at +25°C (mA)	.50	.26	.15	.15
Back EMF Suppressed to (Vdc)	N/A	N/A	N/A	-42
Coil Resistance	18Ω	70Ω	290Ω	290Ω

For other coil voltages, consult factory.

FCA-150NC Series, 50 Amps, 1PST/NC (DB) Relay (Continued)

Contact Electrical Characteristics

Contact Type	Rated Current	Rated Voltage
Main Contact	50A	28Vdc
Minimum Operating cycles	Contact rating per pole and load type MAIN Contact	Load Currents in Amps
50,000 cycles	Resistive load	50
20,000 cycles	Inductive load (L/R=5ms)	20
20,000 cycles	Motor load	20
50 cycles	Resistive overload	200
100,000 cycles	No Load	

All endurance ratings are subject to validation - consult factory

Terminals

CODE "B"

Solder Pin Terminals
Tin/Lead Plated

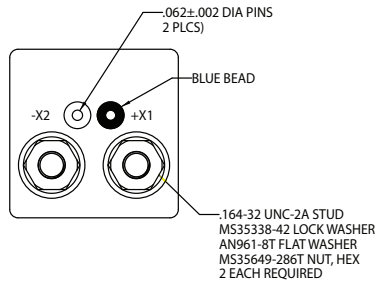
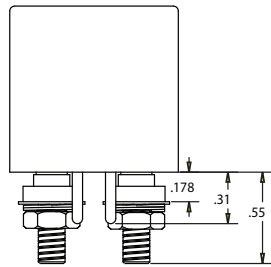

CODE "C"

Solder Hook Terminals
Tin/Lead Plated

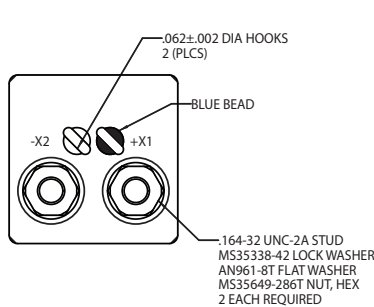
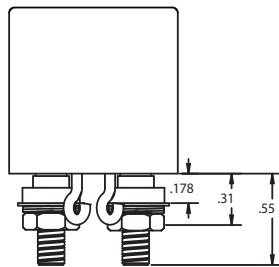

CODE "K"

Terminal Shield

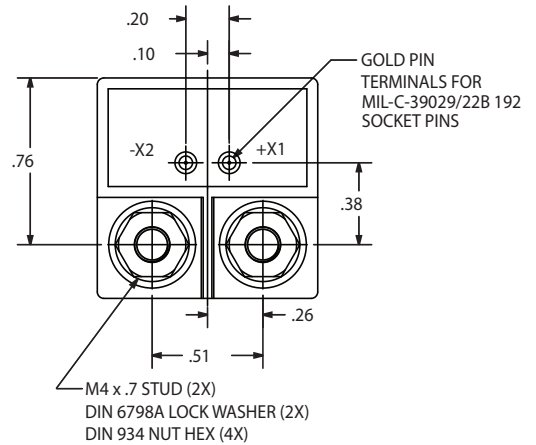

FCA-150NC Series, 50 Amps, 1PST/NC (DB) Relay (Continued)

Outline Dimensions

The standard terminal types and enclosures are illustrated below with dimensions in inches ± 0.010 and (millimeters ± 0.25).

Enclosures

CODE "U"

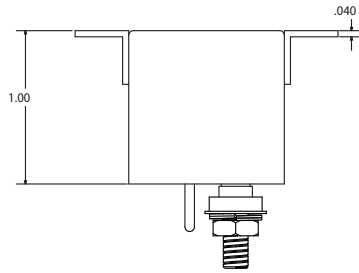
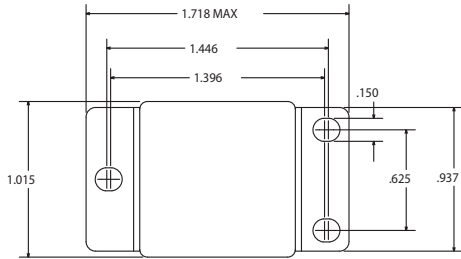

CODE "Y"

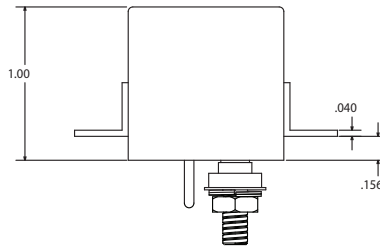
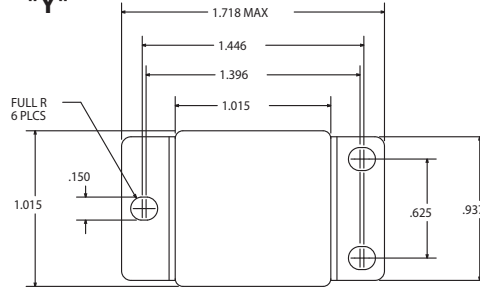

CODE "Z"

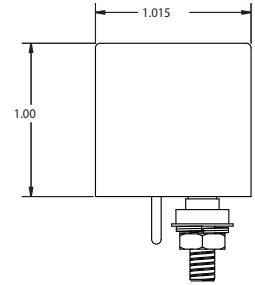
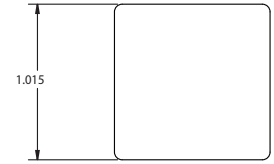

CODE "X"

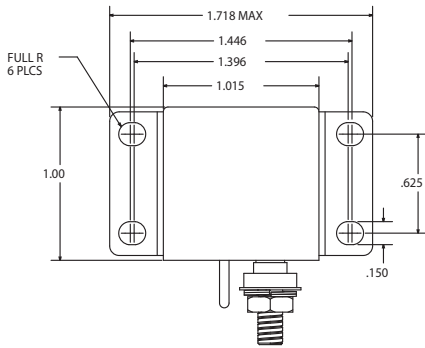
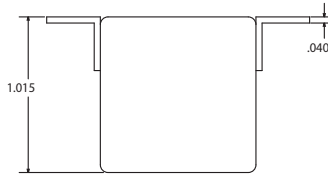

CODE "V"

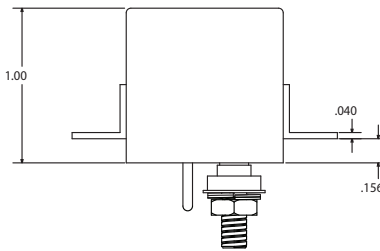
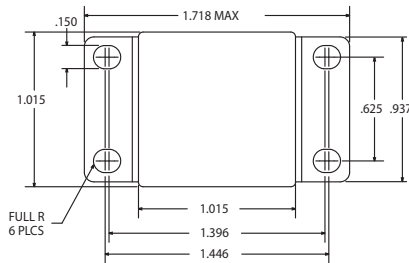

CODE "R"

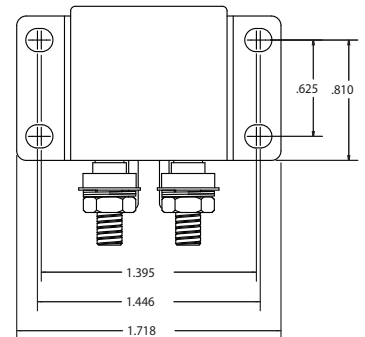
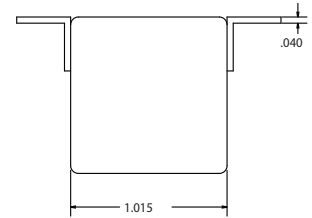

FCA-150NC Series, 50 Amps, 1PST/NC (DB) Relay (Continued)

Terminal Wiring

DC Coils

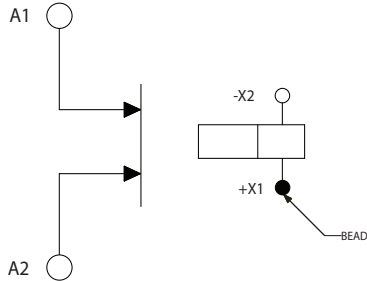

DC Coils with Transient Suppression

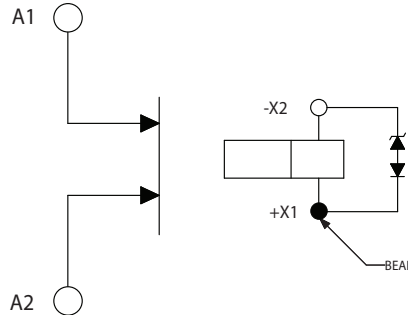

NOTE: Polarity must be observed with DC coil supply. Relay is polarized with a permanent magnet and will not operate or be damaged by reverse polarity.

Diodes used in transient suppression and in AC rectifier circuits have peak inverse voltage rating of 600 VDC minimum. Zener diodes have a minimum rating of 1 watt.

Terminal designations are for reference only and do not appear on the header.

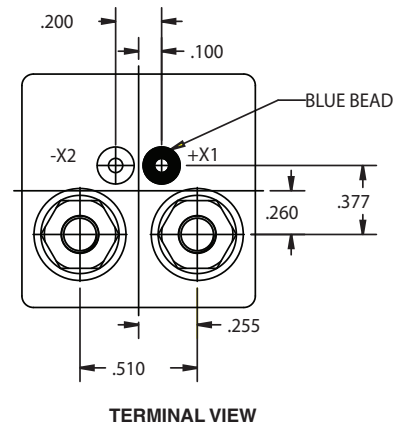

PART NUMBERING SYSTEM

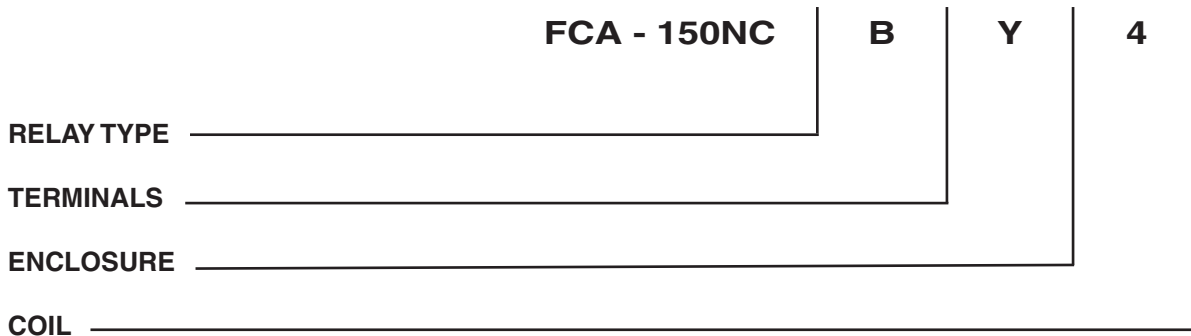

FCAC-150 Series, 50 Amps, 1PST/NO (DM) with 1PDT Auxiliary Contacts

Product Facts

- Non-latching relay
- Balanced force design
- Corrosion protected metal enclosure
- All welded hermetically sealed enclosure occupies about 1 in³ (16.4 cm³)
- 1 Form C (SPDT) auxiliary contact
- 6, 12 and 28 Vdc coils
- Weight: 90 grams
- Designed and built in accordance to MIL-PRF-6106

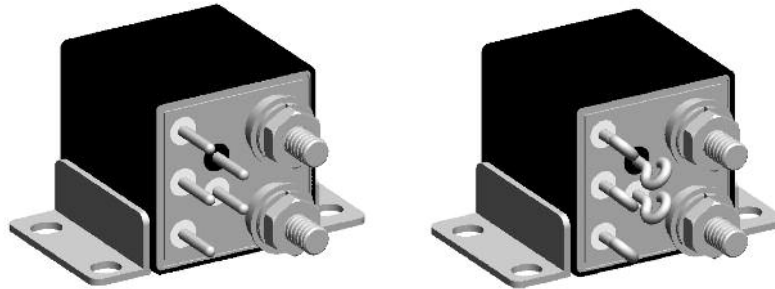

The FCAC-150 series relay is a polarized, single-side stable design, where the flux from a permanent magnet provides the armature holding force in the deactivated state, and its flux path is switched and combined

with the coil flux in the operated state. This results in appreciably increased contact pressure in both states over that of a spring return non-polar design.

A 1 form C (SPDT) auxiliary contact set rated 2 amps is available.

Specifications

Auxiliary Contact Data

Contact Form	1 Form X (SPDT-NO-DM) with 1 Form C (SPDT) Auxiliary
Contact Rating in Amps (Continuous Duty)	

Type of Load	Life (Min.) Cycles	28 Vdc		115 Vac 400Hz	
Resistive	50,000	50	50	50	50
Inductive (L/R=5ms)	20,000	20	20	20	20
Motor	20,000	20	20	20	20
None	100,000	—	—	—	—

Coil Data

Coil Code	1	2	3	4(A)
Nominal Operating Voltage (Vdc)	6	12	28	28
Maximum Operating Voltage (Vdc)	7.3	14.5	29	29
Maximum Pick-Up Voltage at +125°C	4.5	9	18	18
Maximum Pick-Up Voltage at +125°C, continuous current test (Vdc)	5.7	11.25	22.5	22.5
Drop-Out Voltage at OTR	0.3 – 2.5	0.75 – 4.5	1.5 – 7.0	1.5 – 7.0
Maximum Coil Current at +25°C (mA)	.50	.26	.15	.15
Back EMF Suppressed to (Vdc) (max)	N/A	N/A	N/A	-42
Coil Resistance ±10%	18Ω	70Ω	290Ω	290Ω

FCAC-150 Series, 50 Amps, 1PST/NO (DM) with 1PDT Auxiliary Contacts (Continued)

Specifications

Electrical Data

Initial Insulation Resistance (note 1)	100 megohms, minimum, at 500Vdc, between each pin and case
Insulation Resistance After Life or Environmental Test (note 1)	50 megohms, minimum, at 500Vdc, between each pin and case
Dielectric Strength At Sea Level	
Contacts to Ground and Between Contacts	1,250Vrms, 60 Hz.
Coil to Ground	1,000Vrms, 60 Hz.
Dielectric Strength at 80,000 ft (25,000m), All Points (note 4)	
	500Vrms, 60 Hz

Environmental Data

Ambient Temperature Range, Operating	-70°C to +125°C
Altitude	300,000 feet
Shock Resistance	50 G's, 11 ms.
Vibration Resistance, Sinusoidal	20 G's, 75-3000Hz.

Mechanical Data

Approximate Weight	3.2 oz. (90g) Max.
--------------------	--------------------

NOTES

1. All wired terminals must be connected together during this test. Dielectric withstanding voltage and insulation resistance are measured between all mutually insulated wired terminals and between all these terminals and case.

Terminals

CODE "B"

Solder Pin Terminals
Tin/Lead Plated

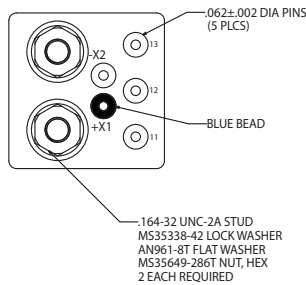
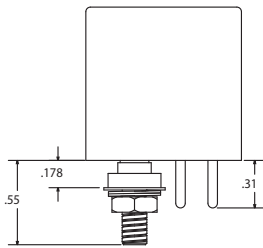

CODE "C"

Solder Hook Terminals
Tin/Lead Plated

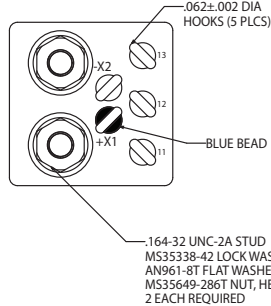
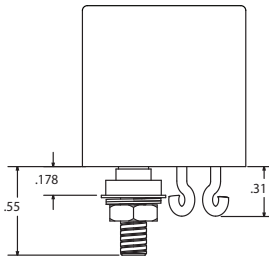

CODE "K"

Terminal Shield

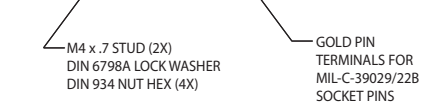
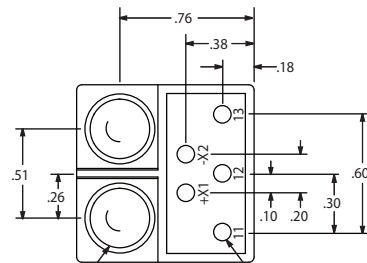

FCAC-150 Series, 50 Amps, 1PST/NO (DM) with 1PDT Auxiliary Contacts (Continued)

Outline Dimensions

The standard terminal types and enclosures are illustrated below with dimensions in inches ± 0.010 and (millimeters ± 0.25).

Enclosures

**CODE
"U"**

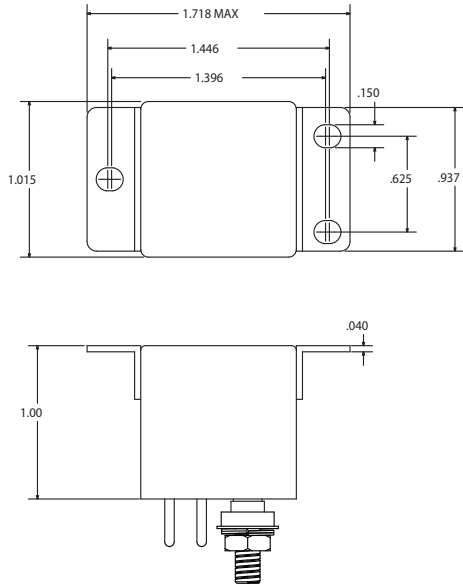

**CODE
"Y"**

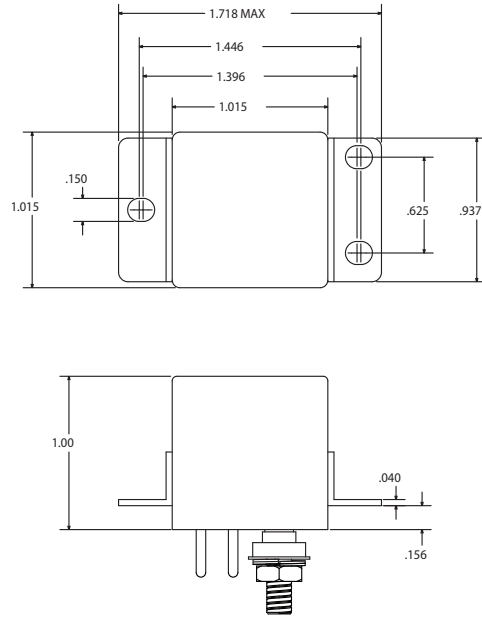

**CODE
"X"**

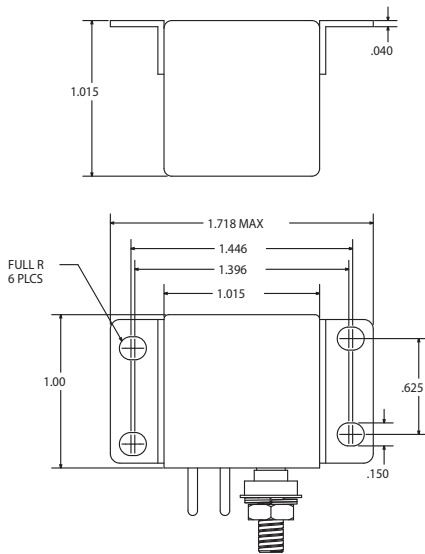

**CODE
"R"**

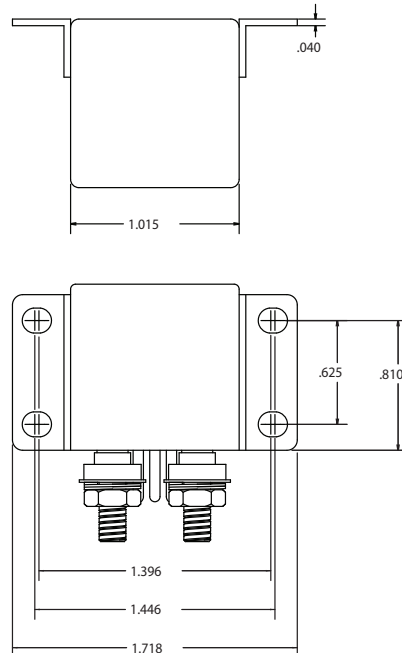

FCAC-150 Series, 50 Amps, 1PST/NO (DM) with 1PDT Auxiliary Contacts (Continued)

Terminal Wiring

DC Coils

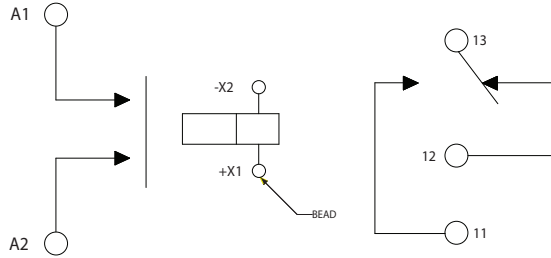

DC Coils with Transient Suppression

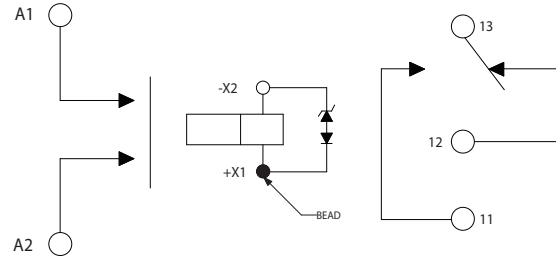

NOTE: Polarity must be observed with DC coil supply. Relay is polarized with a permanent magnet and will not operate or be damaged by reverse polarity.

Diodes used in transient suppression and in AC rectifier circuits have peak inverse voltage rating of 600 VDC minimum. Zener diodes have a minimum rating of 1 watt.

Terminal designations are for reference only and do not appear on the header.

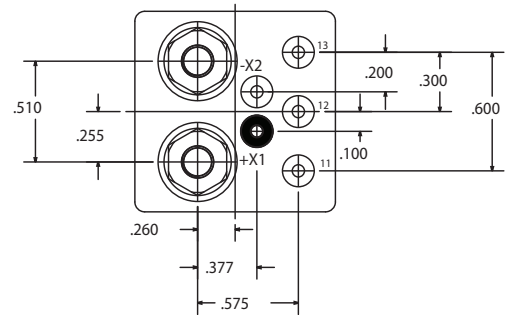

TERMINAL VIEW

How to Order

Typical Part Number	FCAC-150	B	Y	3
Series and Contact Arrangement: FCAC-150 = Relay with 1 Form X Main Contacts, 1 Form C Aux. Contacts				
Terminals (see drawings for details): B = Solder Pin Coil Terminals, Stud Power Terminals C = Solder Hook Coil Terminals, Stud Power Terminals K = Terminal Block, Stud Power Terminals				
Enclosure (see drawings for details): R = Horizontal Flange Mount, Rotated U = Flush Vertical Flange Mount X = Horizontal Flange Mount Y = Raised Vertical Flange Mount Z = No Mount				
Coil: 1 = 6Vdc nominal 2 = 12Vdc nominal 3 = 28Vdc nominal 4 = 28Vdc nominal, with back EMF suppression				

Selection and Application Guide

This selection and application guide is suggested practices from ARP (Aerospace Recommended Practice) 4005 Concerning proper performance of relays.

Caution:

The use of any coil voltage less than the rated coil voltage may compromise the operation of the relay. Choosing the proper relay depends primarily on matching the relay to the load, power supply, and environment. Selection should be limited to items that meet the following requirements:

- A. Contacts** must be rated for the load. Current rating, type of load (resistive, lamp, motor, inductive, and so forth), impedance range, voltage rating, DC or AC, frequency, single phase or polyphase, polyphase load balance, and type of switching or transfer should all be considered. Each of the following switching and transfer functions places a different requirement on each of the relay contacts and must be considered when selecting a relay with the proper contact rating:
 - (1) On-Off Switching - DC, single phase or polyphase
 - (2) Motor Reversing (AC or DC)
 - (3) Transferring load between phases of same source
 - (4) Transferring load between unsynchronized AC sources
- B. Power supply characteristics** must be taken into account. Voltage regulation, variations in frequency, ripples and spikes, as well as steady state conditions, should be included. If more than one power supply is involved, not only must each be suitable but interaction between them also should be investigated.
- C. Coil (or coils)** should be rated so as to have proper operation under all anticipated conditions.
- D. Consideration of environmental conditions** anticipated throughout the service of life, as well as those expected during storage and transportation before installing the relays in equipment, is mandatory. Electrical parameters, environmental factors, mechanical stresses, and compatibility are among the categories for which the relay must be reviewed.
- E. The circuit in which the relay is used**, the interlocking feature employed, the wiring harness, and the associated components should all be reviewed for assuring mutual suitability.
- F. Relays should be hard wired** whenever possible, to avoid the need for additional contact points associated with the relay plug-in socket arrangement. (Plug-in types should be considered for quick turnaround times).
- G. To permit "safe" isolation** of relay circuit in the OFF condition, and better eliminate an electrical shock hazard, an electromechanical switching device should be placed between the positive terminal of the power source and relay coil.
- H. Proper transistor control** of the relay coil requires a stable reference voltage. This can be done by connecting the plus side of the coil to the positive side of the power source, the minus side of the relay coil to the collector of an NPN transistor, the emitter of the transistor to the grounded side of the power source, and the transistor base to the control voltage. For example, see MIL-R-28776/1.
- I. Any switching device** controlling the relay coil circuit must be capable of withstanding, without damage, the sum of the maximum coil circuitry voltage and the peak value of transient voltage that results when the coil circuit is opened; for example, a switch controlling a relay coil that is supplied with a 28V DC line and subjected to a transient voltage suppressed to 42V must be capable of withstanding 28V + 42V or a 70V surge without damage.
- J. In selecting solid state electronic switching devices** to control relay coil circuits, care must be used in selecting a solid state device with a leakage current (in the "off state") that is sufficiently low to permit the relay to drop out.
- K. Control of the relay coil circuit** by other than step-function switching may invalidate published relay performance properties such as pickup and dropout voltages, pickup, dropout, and bounce times.

Cross Reference - Socket to Relay

NOTE:
TE Connectivity Does Not Manufacture Relay Sockets.

This Socket to Relay cross reference is provided for additional design assistance. Several of TE Authorized Distributors carry relay sockets for your convenience. Relay sockets come with a variety of profiles, mounting styles, and mounting hardware options, so please contact the relay socket supplier of your choice or one of our Authorized Distributors who carry relay sockets for additional information.

Military Socket P/N	Relay Part Number	Relay Type
M12883/40-01		
M12883/40-05		
M12883/40-07		
M12883/40-11	M83536/15-022	4 Pole, 10 Amp
M12883/40-13	M83536/16-006, 014, 031, 034	
M12883/40-17		
M12883/40-19		
M12883/40-23		
M12883/40-02		
M12883/40-08	FCA-410-DY8 (Catalog Version)	4 Pole, 10 Amp, AC
M12883/40-14	FCA-410-DY9 (Catalog Version)	
M12883/40-20		
M12883/41-01		
M12883/41-04		
M12883/41-06		
M12883/41-09	M83536/9-006, 015, 024, 035	2 Pole, 10 Amp
M12883/41-11	M83536/10-006, 015, 024, 034, 038	
M12883/41-14		
M12883/41-16		
M12883/41-19		
M12883/41-02		
M12883/41-07	FCA-210-DY8 (Catalog Version)	2 Pole, 10 Amp, AC
M12883/41-12	FCA-210-DY9 (Catalog Version)	
M12883/41-17		
M12883/44-01	M83536/5-006, 014, 022, 030	4 Pole, 5 Amp
	M83536/6-006, 014, 022, 032	
M12883/45-01	M83536/1-006, 015, 024, 033	2 Pole, 5 Amp
	M83536/2-006, 015, 024, 035	
M12883/47-01		
M12883/47-04	FCA-610-AY3 (Catalog Version)	6 Pole, 10 Amp
M12883/47-07	FCA-610-AY4 (Catalog Version)	
M12883/47-10		
M12883/47-02		
M12883/47-05	FCA-610-DY8 (Catalog Version)	6 Pole, 10 Amp
M12883/47-08		AC
M12883/47-11		
M12883/48-01		
M12883/48-02	M83536/32-003L	3 Pole, 25 Amp
M12883/48-03	M83536/33-003L	
M12883/48-04		
M12883/48-05		
M12883/48-06	FCA-325-AV8 (Catalog Version)	3 Pole, 25 Amp
M12883/48-07	FCA-325-AV9 (Catalog Version)	AC
M12883/48-08		
M12883/52-01	M83536/2-028	2 Pole, 5 Amp Track Mount
M12883/52-02	M83536/6-025	4 Pole, 5 Amp Track Mount
M12883/55-01		
M12883/55-02	M6106/19-004, 007, 012, 017, 022	1 Pole, 25 Amp

Engineering Notes

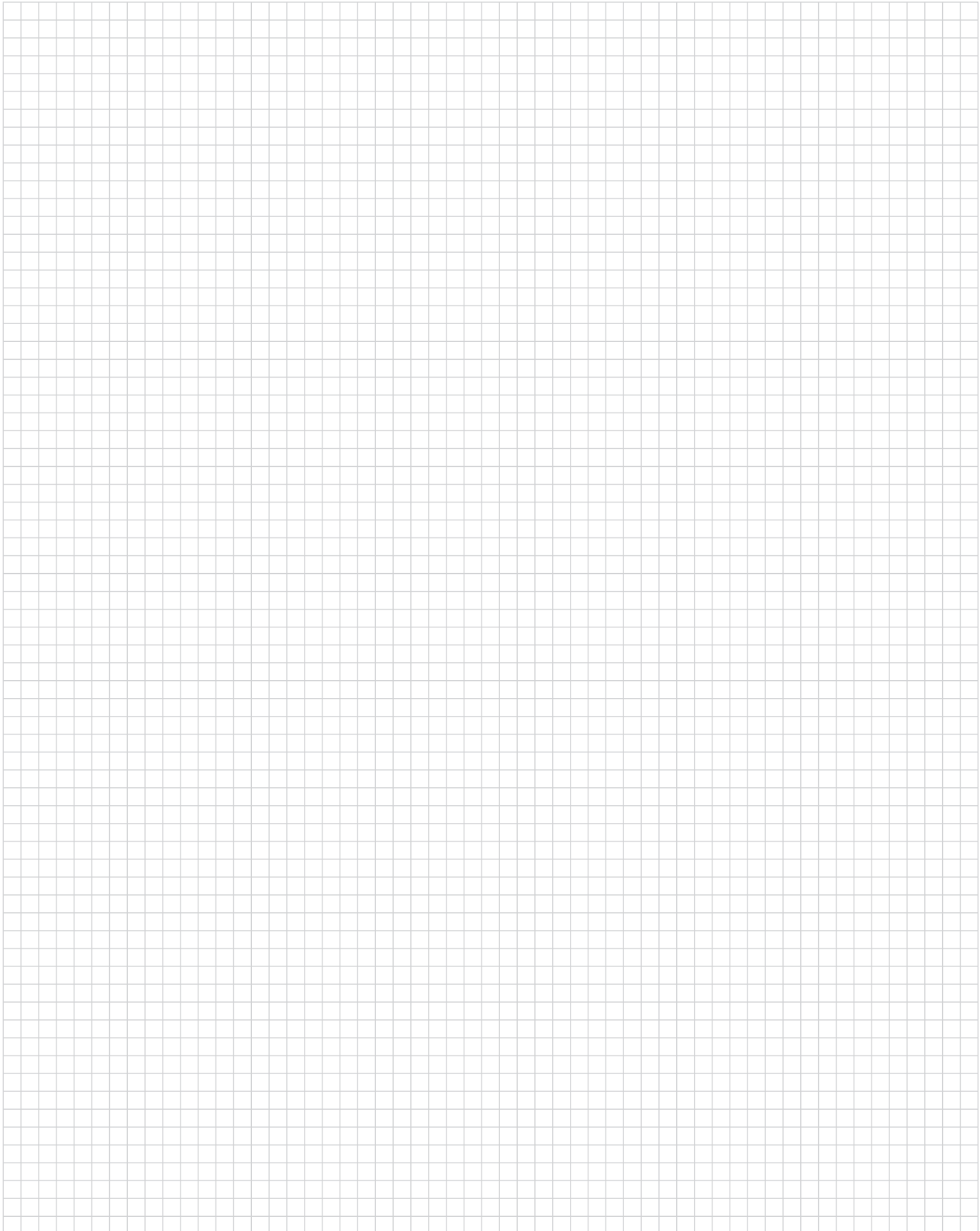

Данный компонент на территории Российской Федерации

Вы можете приобрести в компании MosChip.

Для оперативного оформления запроса Вам необходимо перейти по данной ссылке:

<http://moschip.ru/get-element>

Вы можете разместить у нас заказ для любого Вашего проекта, будь то серийное производство или разработка единичного прибора.

В нашем ассортименте представлены ведущие мировые производители активных и пассивных электронных компонентов.

Нашей специализацией является поставка электронной компонентной базы двойного назначения, продукции таких производителей как XILINX, Intel (ex.ALTERA), Vicor, Microchip, Texas Instruments, Analog Devices, Mini-Circuits, Amphenol, Glenair.

Сотрудничество с глобальными дистрибьюторами электронных компонентов, предоставляет возможность заказывать и получать с международных складов практически любой перечень компонентов в оптимальные для Вас сроки.

На всех этапах разработки и производства наши партнеры могут получить квалифицированную поддержку опытных инженеров.

Система менеджмента качества компании отвечает требованиям в соответствии с ГОСТ Р ИСО 9001, ГОСТ РВ 0015-002 и ЭС РД 009

Офис по работе с юридическими лицами:

105318, г.Москва, ул.Щербаковская д.3, офис 1107, 1118, ДЦ «Щербаковский»

Телефон: +7 495 668-12-70 (многоканальный)

Факс: +7 495 668-12-70 (доб.304)

E-mail: info@moschip.ru

Skype отдела продаж:

moschip.ru

moschip.ru_4

moschip.ru_6

moschip.ru_9