



# 38 series

## Potential Motor Starting Relay 1-pole, 35A, Normally Closed AC Coil

**us** File E83865

Users should thoroughly review the technical data before selecting a product part number. It is recommended that users also seek out the pertinent approvals files of the agencies/laboratories and review them to ensure the product meets the requirements for a given application.

### Features

- Single-pole, normally closed relay used extensively in HVAC applications.
- Variety of mounting positions and brackets.
- Convenient 0.250" (6.35 mm) quick connect terminals.
- Custom-built to meet customer requirements.

### Contact Data @ 25°C

**Arrangements:** Normally-Closed.

**Materials:** Silver cadmium oxide.

**Maximum Rating:** 35A inductive @ 277VAC, 0.5 power factor (Break only)

**Expected Life:** 750,000 ops, mechanical.  
250,000 ops., breaking rated load.

### Initial Dielectric Strength

**Initial Breakdown Voltage:** 1,554 VAC @ 60 Hz. between live parts and exposed non-current carrying metal parts.

### Coil Data @ 25°C

**Voltage:** 130, 170, 214, 256, 336, 395, 420 and 495 VAC, 60 Hz.

**Nominal Sealed Power:** 5 VA).

**Insulation Class:** UL Class B (130°C).

**Duty Cycle:** Continuous.

### Mechanical Data

**Termination:** 0.250" (6.35 mm) quick connects (single or dual, model dependent). Terminals #4 & #6 are dummies for customer convenience.

**Mounting Position:** Each model is calibrated for its specified mounting position. Pick-up voltage may vary if relay is mounted in positions other than specified.

**Weight:** 5.76 oz. (163.8 g) approximately

### Ordering Information

Typical Part No. ▶	38	-A	144	C	3	000
<b>1. Series:</b> 38 = 1-pole, normally-closed, potential motor starting relay						
<b>2. Wiring and Terminal Type (number of QCs at given base locations):</b> A = 2 @ loc. 1, 2 @ loc. 2, 4 @ loc. 3, 2 @ loc. 5 and 2 @ loc. 6. D = 2 @ loc. 1, 2 @ loc. 2, 4 @ loc. 3, 2 @ loc. 5 and 0 @ loc. 6. M = 2 @ loc. 1, 2 @ loc. 2, 2 @ loc. 3, 2 @ loc. 5 and 0 @ loc. 6. R = 1 @ loc. 1, 2 @ loc. 2, 0 @ loc. 3, 1 @ loc. 5 and 0 @ loc. 6. S = 1 @ loc. 1, 2 @ loc. 2, 0 @ loc. 3, 2 @ loc. 5 and 0 @ loc. 6. T = 2 @ loc. 1, 2 @ loc. 2, 0 @ loc. 3, 2 @ loc. 5 and 0 @ loc. 6. Y = 1 @ loc. 1, 2 @ loc. 2, 4 @ loc. 3, 2 @ loc. 5 and 0 @ loc. 6.						
<b>3. Coil Rating and Calibration:</b> 000-999 = See table on following page for details.						
<b>4. Mounting Bracket Style:</b> C, D, F or J = See drawings below for details.						
<b>5. Mounting Position:</b> 1, 2, 3, 4, 5 & 6 = See drawings below for details. NOTE: Devices calibrated in specified mounting position only.						
<b>6. Customer ID Suffix:</b> 000-999 = Factory assigned customer ID						

**Standard part numbers listed below are more likely to be available from stock.**

Custom parts only.

**Coil Rating & Calibration Table**

Select proper continuous coil voltage from top of appropriate column, select pick - up (PU) and drop-out (DO) voltages and insert relay calibration (RC) number in part number.

COIL #1 130 V 60 Hz 117 V 50 Hz*			COIL #2 170 V 60 Hz 151 V 50 Hz*			COIL #3 256 V 60 Hz 228 V 50 Hz*			COIL #4 336 V 60 Hz 299 V 50 Hz*		
RES.@ 1480±10%			RES.@ 2040±10%			RES.@ 5100±10%			RES.@ 6800±10%		
24°C			24°C			24°C			24°C		
RC#	PU	DO	RC#	PU	DO	RC#	PU	DO	RC#	PU	DO
1			2	159-172	20-77	3	240-269	45-95	4	243-271	55-125
8			9			10	259-288	45-95	11	261-290	55-125
15			16			17	278-306	45-115	18	280-309	55-125
22			23			24	296-325	45-115	25	299-327	55-125
29			30			31	315-343	45-115	32	317-345	55-125
36			37			38	323-352	45-115	39	326-354	55-125
43			44			45	333-363	45-115	46	335-364	55-125
50			51			52	285-305	MAX. 77	53	340-370	55-125
57	111-125	20-50	58	111-124	30-65	59	240-269	35-77	60	171-184	40-90
64	121-134	20-50	65	120-134	30-65	66	123-134	25-77	67	168-182	MAX. 90
71	130-143	20-55	72	130-144	30-65	73			74	180-195	40-90
78	139-153	20-55	79	140-153	30-65	80	136-150	45-90	81	219-253	40-115
85	149-163	20-55	86	149-163	30-65	87	150-163	45-90	88	152-166	55-115
92			93	159-172	30-65	94	159-172	45-90	95	162-175	55-115
99			100	168-182	30-65	101	168-182	45-95	102	171-184	55-115
106			107	178-192	30-75	108	178-192	45-95	109	180-193	55-115
113			114	139-153	MAX. 55	115	185-213	45-95	116	188-214	55-115
120			121			122	203-231	45-95	123	205-234	55-115
127			128			129	221-250	45-95	130	224-252	55-125
134			135			136	140-152	33-77	137	186-215	40-90
141	80-110	20-55	142			143	285-305	45-115	144	162-175	40-90
148	62-76	20-45	149			150	159-172	35-77	151	162-175	70-100
156			157			158	150-162	MAX. 77	159	243-271	40-90
163			164			165	136-150	MAX. 50	166	205-234	40-90
170			171			172	166-182	35-77	173	180-195	MAX. 105
178			179			180			181	224-252	40-90
185			186			187			188	280-309	55-100
									194	205-234	40-90
									198	152-166	40-90

COIL #5 395 V 60 Hz 338 V 50 Hz*			COIL #6 420 V 60 Hz 378 V 50 Hz*			COIL #7 495 V 60 Hz 452 V 50 Hz*			COIL #8 214 V 60 Hz 193 V 50 Hz*		
RES.@ 9600±10%			RES.@ 12700±10%			RES.@ 15200±10%			RES.@ 2840±10%		
24°C			24°C			24°C			24°C		
RC#	PU	DO	RC#	PU	DO	RC#	PU	DO	RC#	PU	DO
5	245-275	60-140	6	242-272	75-150	7	239-268	75-170	193	158-171	25-57
12	262-290	60-140	13	262-290	75-150	14	258-287	75-170	196	120-134	25-56
19	280-310	60-140	20	280-310	75-160	21	277-305	75-170	197	129-142	25-57
26	305-335	60-140	27	300-328	75-160	28	295-324	75-170			
33	187-208	60-130	34	318-347	75-160	35	314-342	75-180			
40	326-354	60-140	41	328-356	75-150	42	323-352	75-180			
47	335-365	60-140	48	337-366	75-160	49	332-361	75-180			
54	340-370	60-140	55	340-370	75-160	56	258-287	60-135			
61	180-195	40-105	62	300-328	75-121	63					
68	215-225	MAX.120	69	300-328	MAX.125	70	323-352	MAX.135			
75	334-363	50-110	76	212-232	MAX.121	77	277-305	75-150			
82	298-326	50-110	83	195-224	60-121	84	295-324	60-135			
89	189-205	60-130	90	204-233	60-121	91	325-345	MAX.135			
96	162-175	50-100	97	260-290	60-121	98					
103	180-195	50-100	104	242-272	60-121	105					
110	180-195	60-130	111	180-195	60-121	112	239-268	60-135			
117	190-215	60-130	118	190-215	60-121	119	325-345	75-170			
124	208-239	60-130	125	204-233	75-150	126	277-305	60-135			
131	223-254	60-140	132	223-252	75-150	133					
138	245-275	MAX.120	139	195-224	75-150	140					
145	208-239	MAX.120	146	320-340	60-121	147					
152	260-275	MAX.120	153	295-315	MAX.195	154					
160	260-275	60-140	161	218-243	60-121	162					
167	215-225	60-130	168	205-234	40-90	169					
174	239-270	50-110	175	223-252	60-121	176					
182	208-239	50-110	183	295-315	MAX.125	184					
189	224-252	60-121	190	280-310	60-121	191					
195	190-215	40-105	192	180-195	40-105						
200	279-308	50-110									

\*For 50 Hz, add 300 to RC# - i.e. for 151 V 50 Hz, RC# 58 changes to 358.

**Outline Dimensions**

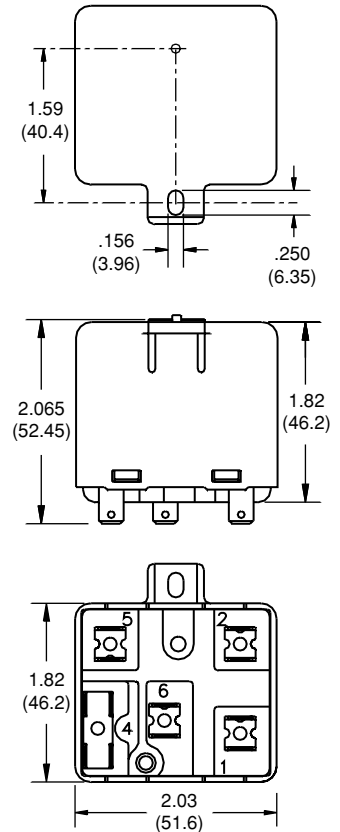

## Данный компонент на территории Российской Федерации

### Вы можете приобрести в компании MosChip.

Для оперативного оформления запроса Вам необходимо перейти по данной ссылке:

<http://moschip.ru/get-element>

Вы можете разместить у нас заказ для любого Вашего проекта, будь то серийное производство или разработка единичного прибора.

В нашем ассортименте представлены ведущие мировые производители активных и пассивных электронных компонентов.

Нашей специализацией является поставка электронной компонентной базы двойного назначения, продукции таких производителей как XILINX, Intel (ex.ALTERA), Vicor, Microchip, Texas Instruments, Analog Devices, Mini-Circuits, Amphenol, Glenair.

Сотрудничество с глобальными дистрибьюторами электронных компонентов, предоставляет возможность заказывать и получать с международных складов практически любой перечень компонентов в оптимальные для Вас сроки.

На всех этапах разработки и производства наши партнеры могут получить квалифицированную поддержку опытных инженеров.

Система менеджмента качества компании отвечает требованиям в соответствии с ГОСТ Р ИСО 9001, ГОСТ РВ 0015-002 и ЭС РД 009

### Офис по работе с юридическими лицами:

105318, г.Москва, ул.Щербаковская д.3, офис 1107, 1118, ДЦ «Щербаковский»

Телефон: +7 495 668-12-70 (многоканальный)

Факс: +7 495 668-12-70 (доб.304)

E-mail: [info@moschip.ru](mailto:info@moschip.ru)

Skype отдела продаж:

moschip.ru

moschip.ru\_4

moschip.ru\_6

moschip.ru\_9