

SIX CHANNEL HD AUDIO CODEC

92HD73C

PREMIUM WLP 3/4 COMPLIANT

Description

The 92HD73C codec is a low power optimized, high fidelity, 6-channel audio codec compatible with Intel's High Definition (HD) Audio Interface. The 92HD73C codec provides stereo 24-bit resolution with sample rates up to 192kHz. Dual SPDIF provides connectivity to consumer electronic equipment that is WLP compliant. The 92HD73C provides high quality, HD Audio capability to multimedia notebook and desktop PC applications.

Features

- **6 Channels (3 stereo DACs and 2 stereo ADCs) with 24-bit resolution**
 - Supports 5.1 audio
- **Microsoft WLP 3/4 premium logo compliant, as defined in WLP 3.09**
- **Optimized and flexible power management with pop/click mitigation**
- **2 independent S/PDIF Output converters for WLP compliant HDMI/SPDIF support.**

- **Support for 1.5V and 3.3V HDA signaling with runtime selection**
- **Digital microphone input (mono, stereo, or quad array)**
- **4 adjustable VREF Out pins for microphone bias**
- **High performance analog mixer**
- **9 stereo analog ports with presence detect capability**
- **Two-pin volume up/down control**
- **Digital and Analog PC BEEP to all outputs**
- **Integrated headphone amps (3)**
- **Sample rates up to 192kHz**
- **+3.3 V, +4 V, +4.75 V and +5 V analog power supply options**
- **Package Options**
 - 48-pin QFP RoHS package
 - 48-pin QFP RoHS package INDUSTRIAL TEMP

Block Diagram

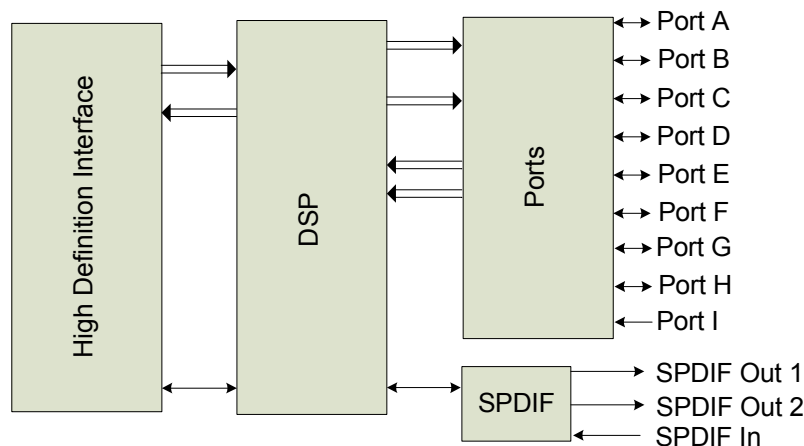

Software Support

- Intuitive graphical user interface that allows configurability and preference settings
- SKPI (Kernel Processing Interface)
 - Enables plug-ins that can operate globally on all audio streams of the system
- 12 band fully parametric equalizer (SKPI plug-in)
 - Constant, system-level effects tuned to optimize a particular platform can be combined with user-mode “presets” tailored for specific acoustical environments and applications
 - System-level effects automatically disabled when external audio connections made
- Dynamics Processing (SKPI plug-in)
 - Enables improved voice articulation
 - Compressor/limiter allows higher average noise level without resonances or damage to speakers.
- IDT Vista APO wrapper
 - Enables multiple APOs to be used with the IDT Driver
- Microphone Beam Forming, Acoustic Echo Cancellation, and Noise Suppression
- Dynamic Stream Switching
 - Improved multi-streaming user experience with less support calls
- Dolby PC Entertainment Experience Logo Program
 - Dolby Master Studio™ (MS)
 - Dolby Home Theater™ (HT)
 - Dolby Sound Room™ (SR)
- Dolby Technologies
 - Dolby Headphone™, Dolby Virtual Speaker™
 - Dolby ProLogic II™, Dolby ProLogic IIx™
 - Dolby Digital Live™ (DDL)
- Maxx Player™ from Waves
- WOW™ and Tru Surround™ from SRS

TABLE OF CONTENTS

| | |
|---|-----------|
| 1. DESCRIPTION | 11 |
| 1.1. Overview | 11 |
| 1.2. Orderable Part Numbers | 11 |
| 1.3. Block Diagram | 12 |
| 1.4. Detailed Description | 13 |
| 1.4.1. Port Functionality | 13 |
| 1.4.2. Port Characteristics | 13 |
| 1.4.3. Jack Detect | 14 |
| 1.4.4. SPDIF Output | 14 |
| 1.4.5. SPDIF Input | 16 |
| 1.4.6. Analog Mixer | 16 |
| 1.4.7. Input Multiplexers | 17 |
| 1.4.8. ADC Multiplexers | 17 |
| 1.4.9. Power Management | 17 |
| 1.4.10. Low-voltage HDA Signaling | 19 |
| 1.4.11. Multi-channel capture | 19 |
| 1.4.12. EAPD | 21 |
| 1.4.13. Digital Microphone Support | 23 |
| 1.4.14. PC-Beep | 28 |
| 1.4.15. Headphone Drivers | 28 |
| 1.4.16. GPIO | 29 |
| 1.4.17. External Volume Control | 30 |
| 2. CHARACTERISTICS | 32 |
| 2.1. Electrical Specifications | 32 |
| 2.1.1. Absolute Maximum Ratings | 32 |
| 2.1.2. Recommended Operating Conditions | 32 |
| 2.2. 92HD73C 5V, 4.75V, and 3.3V Analog Performance Characteristics | 33 |
| 3. PORT CONFIGURATIONS | 39 |
| 4. FUNCTIONAL BLOCK DIAGRAMS | 40 |
| 5. WIDGET INFORMATION AND SUPPORTED COMMAND VERBS | 41 |
| 5.1. Widget List | 42 |
| 5.2. Pin Configuration Default Register Settings | 43 |
| 6. WIDGET INFORMATION | 44 |
| 6.1. Root Node (NID = 00) | 44 |
| 6.1.1. Root VendorID | 44 |
| 6.1.2. Root RevID | 45 |
| 6.2. AFG Node (NID = 01) | 46 |
| 6.2.1. AFG Reset | 46 |
| 6.2.2. AFG NodeInfo | 46 |
| 6.2.3. AFG FGType | 46 |
| 6.2.4. AFG AFGCap | 47 |
| 6.2.5. AFG PCMCap | 48 |
| 6.2.6. AFG StreamCap | 49 |
| 6.2.7. AFG InAmpCap | 49 |
| 6.2.8. AFG PwrStateCap | 50 |
| 6.2.9. AFG GPIOCnt | 50 |
| 6.2.10. AFG OutAmpCap | 51 |
| 6.2.12. AFG UnsolResp | 52 |
| 6.2.11. AFG PwrState | 52 |
| 6.2.13. AFG GPIO | 53 |
| 6.2.14. AFG GPIOEn | 54 |
| 6.2.15. AFG GPIODir | 55 |
| 6.2.16. AFG GPIOWakeEn | 56 |

| | |
|-----------------------------------|----|
| 6.2.17. AFG GPIOUnsol | 58 |
| 6.2.18. AFG GPIOSticky | 59 |
| 6.2.19. AFG SubID | 60 |
| 6.2.20. AFG GPIOIrty | 61 |
| 6.2.21. AFG GPIODrive | 62 |
| 6.2.22. AFG DMic | 63 |
| 6.2.23. AFG AnaBeep | 64 |
| 6.3. Port A Node (NID = 0A) | 64 |
| 6.3.1. PortA WCap | 64 |
| 6.3.2. PortA PinCap | 65 |
| 6.3.3. PortA ConLst | 66 |
| 6.3.4. PortA ConLstEntry0 | 67 |
| 6.3.5. PortA ConSelectCtrl | 67 |
| 6.3.6. PortA PinWCntrl | 68 |
| 6.3.7. PortA UnsolResp | 68 |
| 6.3.8. PortA ChSense | 69 |
| 6.3.9. PortA InAmpLeft | 70 |
| 6.3.10. PortA InAmpRight | 70 |
| 6.3.11. PortA ConfigDefault | 70 |
| 6.4. PortB Node (NID = 0B) | 72 |
| 6.4.1. PortB WCap | 72 |
| 6.4.2. PortB PinCap | 73 |
| 6.4.3. PortB ConLstEntry0 | 74 |
| 6.4.4. PortB ConLstEntry0 | 74 |
| 6.4.5. PortB ConSelectCtrl | 75 |
| 6.4.6. PortB PinWCntrl | 75 |
| 6.4.7. PortB UnsolResp | 76 |
| 6.4.8. PortB ChSense | 77 |
| 6.4.9. PortB InAmpLeft | 77 |
| 6.4.10. PortD InAmpRight | 78 |
| 6.4.11. PortB ConfigDefault | 78 |
| 6.5. Port C Node (NID = 0C) | 79 |
| 6.5.1. PortC WCap | 79 |
| 6.5.2. PortC PinCap | 81 |
| 6.5.3. PortC ConLst | 82 |
| 6.5.4. PortC ConLstEntry0 | 82 |
| 6.5.5. PortC ConSelectCtrl | 83 |
| 6.5.6. PortC PinWCntrl | 83 |
| 6.5.7. PortC UnsolResp | 84 |
| 6.5.8. PortC ChSense | 84 |
| 6.5.9. PortC InAmpLeft | 85 |
| 6.5.10. PortC InAmpRight | 85 |
| 6.5.11. PortC ConfigDefault | 86 |
| 6.6. Port D Node (NID = 0D) | 87 |
| 6.6.1. PortD WCap | 87 |
| 6.6.2. PortD PinCap | 89 |
| 6.6.3. PortD ConLst | 90 |
| 6.6.4. PortD ConLstEntry0 | 90 |
| 6.6.5. PortD ConSelectCtrl | 91 |
| 6.6.6. PortD PinWCntrl | 91 |
| 6.6.7. PortD UnsolResp | 92 |
| 6.6.8. PortD ChSense | 92 |
| 6.6.9. PortD InAmpLeft | 93 |
| 6.6.10. PortD InAmpRight | 93 |
| 6.6.11. PortD ConfigDefault | 94 |

| | |
|------------------------------------|-----|
| 6.7. PortE Node (NID = 0E) | 95 |
| 6.7.1. PortE WCap | 95 |
| 6.7.2. PortE PinCap | 96 |
| 6.7.3. PortE ConLst | 97 |
| 6.7.4. PortE ConLstEntry0 | 98 |
| 6.7.5. PortE ConSelectCtrl | 98 |
| 6.7.6. PortE PinWCntrl | 99 |
| 6.7.7. PortE UnsolResp | 99 |
| 6.7.8. PortE ChSense | 100 |
| 6.7.9. PortE InAmpLeft | 101 |
| 6.7.10. PortE InAmpRight | 101 |
| 6.7.11. PortE ConfigDefault | 101 |
| 6.8. PortF Node (NID = 0F) | 103 |
| 6.8.1. PortF WCap | 103 |
| 6.8.2. PortF PinCap | 104 |
| 6.8.3. PortF ConLst | 105 |
| 6.8.4. PortF ConLstEntry0 | 105 |
| 6.8.5. PortF ConSelectCtrl | 106 |
| 6.8.6. PortF PinWCntrl | 106 |
| 6.8.7. PortF UnsolResp | 107 |
| 6.8.8. PortF ChSense | 107 |
| 6.8.9. PortF InAmpLeft | 108 |
| 6.8.10. PortF InAmpRight | 108 |
| 6.9. PortG Node (NID = 10) | 109 |
| 6.9.1. PortG WCap | 109 |
| 6.9.2. PortG PinCap | 110 |
| 6.9.3. PortG ConLst | 111 |
| 6.9.4. PortG ConLstEntry0 | 112 |
| 6.9.5. PortG ConSelectCtrl | 112 |
| 6.9.6. PortG PinWCntrl | 113 |
| 6.9.7. PortG UnsolResp | 113 |
| 6.9.8. PortG ChSense | 114 |
| 6.9.9. PortG InAmpLeft | 114 |
| 6.9.10. PortG InAmpRight | 115 |
| 6.9.11. PortG ConfigDefault | 116 |
| 6.10. PortH Node (NID = 11) | 117 |
| 6.10.1. PortH WCap | 117 |
| 6.10.2. PortH PinCap | 118 |
| 6.10.3. PortH ConLst | 119 |
| 6.10.4. PortH ConLstEntry0 | 120 |
| 6.10.5. PortH ConSelectCtrl | 120 |
| 6.10.6. PortH PinWCntrl | 121 |
| 6.10.7. PortH UnsolResp | 121 |
| 6.10.8. PortH ChSense | 122 |
| 6.10.9. PortH InAmpLeft | 122 |
| 6.10.10. PortH InAmpRight | 123 |
| 6.10.11. PortH ConfigDefault | 124 |
| 6.11. PortI Node (NID = 12) | 125 |
| 6.11.1. PortI WCap | 125 |
| 6.11.2. PortI PinCap | 126 |
| 6.11.3. PortI PinWCntrl | 127 |
| 6.11.4. PortI UnsolResp | 127 |
| 6.11.5. PortI ChSense | 128 |
| 6.11.6. PortI ConfigDefault | 128 |
| 6.12. DMic0 Node (NID = 13) | 130 |

| | |
|-----------------------------------|-----|
| 6.12.1. DMic0 WCap | 130 |
| 6.12.2. DMic0 PinCap | 131 |
| 6.12.3. DMic0 PinWCntrl | 132 |
| 6.12.4. DMic0 InAmpLeft | 132 |
| 6.12.5. DMic0 InAmpRight | 133 |
| 6.12.6. DMic0 ConfigDefault | 133 |
| 6.13. DMic1 Node (NID = 14) | 134 |
| 6.13.1. DMic1 WCap | 134 |
| 6.13.2. DMic1 PinCap | 136 |
| 6.13.3. DMic1 PinWCntrl | 137 |
| 6.13.4. DMic1 InAmpLeft | 137 |
| 6.13.5. DMic1 InAmpRight | 137 |
| 6.13.6. DMic1 ConfigDefault | 138 |
| 6.14. DAC0 Node (NID = 15) | 139 |
| 6.14.1. DAC0 WCap | 139 |
| 6.14.2. DAC0 Cnvtr | 140 |
| 6.14.3. DAC0 OutAmpLeft | 141 |
| 6.14.4. DAC0 OutAmpRight | 142 |
| 6.14.5. DAC0 PwrState | 142 |
| 6.14.6. DAC0 CnvtrID | 143 |
| 6.14.7. DAC0 LR | 143 |
| 6.15. DAC1 Node (NID = 16) | 144 |
| 6.15.1. DAC1 WCap | 144 |
| 6.15.2. DAC1 Cnvtr | 145 |
| 6.15.3. DAC1 OutAmpLeft | 146 |
| 6.15.4. DAC1 OutAmpRight | 147 |
| 6.15.5. DAC1 PwrState | 147 |
| 6.15.6. DAC1 CnvtrID | 148 |
| 6.15.7. DAC1 LR | 148 |
| 6.16. DAC2 Node (NID = 17) | 149 |
| 6.16.1. DAC2 WCap | 149 |
| 6.16.2. DAC2 Cnvtr | 150 |
| 6.16.3. DAC2 OutAmpLeft | 151 |
| 6.16.4. DAC2 OutAmpRight | 152 |
| 6.16.5. DAC2 PwrState | 152 |
| 6.16.6. DAC2 CnvtrID | 153 |
| 6.16.7. DAC2 LR | 153 |
| 6.17. Reserved (NID = 18) | 154 |
| 6.18. Reserved (NID = 19) | 154 |
| 6.19. ADC0 Node (NID = 1A) | 154 |
| 6.19.1. ADC0 WCap | 154 |
| 6.19.2. ADC0 ConLst | 155 |
| 6.19.3. ADC0 ConLstEntry0 | 156 |
| 6.19.4. ADC0 Cnvtr | 156 |
| 6.19.5. ADC0 ProcState | 157 |
| 6.19.6. ADC0 PwrState | 158 |
| 6.19.7. ADC0 CnvtrID | 158 |
| 6.20. ADC1 Node (NID = 1B) | 159 |
| 6.20.1. ADC1 WCap | 159 |
| 6.20.2. ADC1 ConLst | 160 |
| 6.20.3. ADC1 ConLstEntry0 | 161 |
| 6.20.4. ADC1 Cnvtr | 161 |
| 6.20.5. ADC1 ProcState | 162 |
| 6.20.6. ADC1 PwrState | 163 |
| 6.20.7. ADC1 CnvtrID | 163 |

| | |
|-----------------------------------|-----|
| 6.21. DigBeep Node (NID = 1C) | 164 |
| 6.21.1. DigBeep WCap | 164 |
| 6.21.2. DigBeep OutAmpCap | 164 |
| 6.21.3. DigBeep OutAmpLeft | 165 |
| 6.21.4. DigBeep Gen | 166 |
| 6.22. Mixer Node (NID = 1D) | 166 |
| 6.22.1. Mixer WCap | 166 |
| 6.22.2. Mixer ConLst | 168 |
| 6.22.3. Mixer ConLstEntry0 | 168 |
| 6.22.4. Mixer InAmpCap | 169 |
| 6.22.5. Mixer InAmpLeft0 | 169 |
| 6.22.6. Mixer InAmpRight0 | 170 |
| 6.22.7. Mixer InAmpLeft1 | 170 |
| 6.22.8. Mixer InAmpRight1 | 171 |
| 6.22.9. Mixer InAmpLeft2 | 171 |
| 6.22.10. Mixer InAmpRight2 | 172 |
| 6.22.11. Mixer InAmpLeft3 | 172 |
| 6.22.12. Mixer InAmpRight3 | 173 |
| 6.22.13. Mixer InAmpLeft4 | 173 |
| 6.22.14. Mixer InAmpRight4 | 174 |
| 6.23. MixerOutVol Node (NID = 1E) | 174 |
| 6.23.1. MixerOutVol WCap | 174 |
| 6.23.2. MixerOutVol ConLst | 176 |
| 6.23.3. MixerOutVol ConLstEntry0 | 176 |
| 6.23.4. MixerOutVol OutAmpCap | 177 |
| 6.23.5. MixerOutVol OutAmpLeft | 177 |
| 6.23.6. MixerOutVol OutAmpRight0 | 178 |
| 6.24. VolumeKnob Node (NID = 1F) | 178 |
| 6.24.1. VolumeKnob WCap | 178 |
| 6.24.2. VolumeKnob VolKnobCap | 179 |
| 6.24.3. VolumeKnob ConLst | 179 |
| 6.24.4. VolumeKnob ConLstEntry0 | 180 |
| 6.24.5. VolumeKnob UnsolResp | 180 |
| 6.24.6. VolumeKnob Cntrl | 181 |
| 6.24.7. VolumeKnob VS | 181 |
| 6.25. ADC0Mux Node (NID = 20) | 182 |
| 6.25.1. ADC0Mux WCap | 182 |
| 6.25.2. ADC0Mux ConLst | 183 |
| 6.25.3. ADC0Mux ConLstEntry0 | 184 |
| 6.25.4. ADC0Mux ConSelectCtrl | 184 |
| 6.25.5. ADC0Mux LR | 185 |
| 6.25.6. ADC0Mux OutAmpCap | 185 |
| 6.25.7. ADC0Mux OutAmpLeft | 186 |
| 6.25.8. ADC0Mux OutAmpRight | 187 |
| 6.26. ADC1Mux Node (NID = 21) | 187 |
| 6.26.1. ADC1Mux WCap | 187 |
| 6.26.2. ADC1Mux ConLst | 188 |
| 6.26.3. ADC1Mux ConLstEntry0 | 189 |
| 6.26.4. ADC1Mux ConSelectCtrl | 189 |
| 6.26.5. ADC1Mux LR | 190 |
| 6.26.6. ADC1Mux OutAmpCap | 190 |
| 6.26.7. ADC1Mux OutAmpLeft | 191 |
| 6.26.8. ADC1Mux OutAmpRight | 192 |
| 6.27. Dig0Pin Node (NID = 22) | 192 |
| 6.27.1. Dig0Pin WCap | 192 |

| | |
|---------------------------------------|-----|
| 6.27.2. Dig0Pin PinCap | 193 |
| 6.27.3. Dig0Pin ConLst | 194 |
| 6.27.4. Dig0Pin ConLstEntry0 | 195 |
| 6.27.5. Dig0Pin ConSelectCtrl | 195 |
| 6.27.6. Dig0Pin PinWCntrl | 196 |
| 6.27.7. Dig0Pin ConfigDefault | 196 |
| 6.28. Dig1Pin Node (NID = 23) | 198 |
| 6.28.1. Dig1Pin WCap | 198 |
| 6.28.2. Dig1Pin PinCap | 199 |
| 6.28.3. Dig1Pin ConLst | 200 |
| 6.28.4. Dig1Pin ConLstEntry0 | 200 |
| 6.28.5. Dig1Pin ConSelectCtrl | 201 |
| 6.28.6. Dig1Pin PinWCntrl | 201 |
| 6.28.7. Dig1Pin ConfigDefault | 202 |
| 6.29. Dig2Pin Node (NID = 24) | 203 |
| 6.29.1. Dig2Pin WCap | 203 |
| 6.29.2. Dig2Pin PinCap | 205 |
| 6.29.3. Dig2Pin PinWCntrl | 206 |
| 6.29.4. Dig2Pin UnsolResp | 206 |
| 6.29.5. Dig2Pin ChSense | 207 |
| 6.29.6. Dig2Pin PwrState | 207 |
| 6.29.7. Dig2Pin EAPD | 208 |
| 6.29.8. Dig2Pin ConfigDefault | 208 |
| 6.30. SPDIFOut0 Node (NID = 25) | 210 |
| 6.30.1. SPDIFOut0 WCap | 210 |
| 6.30.2. SPDIFOut0 PCMCap | 211 |
| 6.30.3. SPDIFOut0 StreamCap | 212 |
| 6.30.4. SPDIFOut0 Cnvtr | 213 |
| 6.30.5. SPDIFOut0 CnvtrID | 214 |
| 6.30.6. SPDIFOut0 DigCnvtr | 214 |
| 6.30.7. SPDIFOut0 OutAmpCap | 215 |
| 6.30.8. SPDIFOut0 OutAmpLeft | 216 |
| 6.30.9. SPDIFOut0 OutAmpRight | 216 |
| 6.31. SPDIFOut1 Node (NID = 26) | 216 |
| 6.31.1. SPDIFOut1 WCap | 216 |
| 6.31.2. SPDIFOut1 PCMCap | 218 |
| 6.31.3. SPDIFOut1 StreamCap | 219 |
| 6.31.4. SPDIFOut1 Cnvtr | 219 |
| 6.31.5. SPDIFOut1 CnvtrID | 220 |
| 6.31.6. SPDIFOut1 DigCnvtr | 221 |
| 6.31.7. SPDIFOut1 OutAmpCap | 222 |
| 6.31.8. SPDIFOut1 OutAmpLeft | 222 |
| 6.31.9. SPDIFOut1 OutAmpRight | 223 |
| 6.32. SPDIFIn Node (NID = 27) | 223 |
| 6.32.1. SPDIFOut1 WCap | 223 |
| 6.32.2. SPDIFInCnvtr | 225 |
| 6.32.3. SPDIFIn PCMCap | 226 |
| 6.32.4. SPDIFIn StreamCap | 227 |
| 6.32.5. SPDIFIn ConLst | 227 |
| 6.32.6. SPDIFIn ConLstEntry0 | 228 |
| 6.32.7. SPDIFIn CnvtrID | 228 |
| 6.32.8. SPDIFIn DigCnvtr | 229 |
| 6.32.9. SPDIFIn OutAmpCap | 230 |
| 6.32.10. SPDIFIn InAmpLeft | 230 |
| 6.32.11. SPDIFIn InAmpRight | 231 |

| | |
|--|------------|
| 6.32.12. SPDIFIn VS | 231 |
| 6.32.13. SPDIFIn Status | 232 |
| 6.33. InPort0Mux Node (NID = 28) | 235 |
| 6.33.1. InPort0Mux WCap | 235 |
| 6.33.2. InPort0Mux ConLst | 236 |
| 6.33.3. InPort0Mux ConLstEntry0 | 236 |
| 6.33.4. InPort0Mux ConSelectCtrl | 237 |
| 6.34. InPort1Mux Node (NID = 29) | 237 |
| 6.34.1. InPort1Mux WCap | 237 |
| 6.34.2. InPort1Mux ConLst | 239 |
| 6.34.3. InPort1Mux ConLstEntry0 | 239 |
| 6.34.4. InPort1Mux ConSelectCtrl | 240 |
| 6.35. InPort2Mux Node (NID = 2A) | 240 |
| 6.35.1. InPort2Mux WCap | 240 |
| 6.35.2. InPort2Mux ConLst | 241 |
| 6.35.3. InPort2Mux ConLstEntry0 | 242 |
| 6.35.4. InPort1Mux ConSelectCtrl | 242 |
| 6.36. InPort3Mux Node (NID = 2B) | 243 |
| 6.36.1. InPort3Mux WCap | 243 |
| 6.36.2. InPort3Mux ConLst | 244 |
| 6.36.3. InPort3Mux ConLstEntry0 | 245 |
| 6.36.4. InPort3Mux ConSelectCtrl | 245 |
| 7. DISCLAIMER | 246 |
| 8. PINOUTS | 247 |
| 8.1. Pin Assignment | 247 |
| 8.2. Pin Tables for 48-pin QFP | 248 |
| 9. PACKAGE OUTLINE AND PACKAGE DIMENSIONS | 251 |
| 9.1. 48-Pin QFP Package | 251 |
| 10. SOLDER REFLOW PROFILE | 252 |
| 10.1. Standard Reflow Profile Data | 252 |
| 10.2. Pb Free Process - Package Classification Reflow Temperatures | 253 |
| 11. REVISION HISTORY | 253 |

LIST OF FIGURES

| | |
|--|-----|
| Figure 1. 92HD73D Block Diagram | 12 |
| Figure 2. System Diagram | 12 |
| Figure 3. Multi-channel capture | 20 |
| Figure 4. Multi-channel timing diagram | 20 |
| Figure 5. EAPD | 23 |
| Figure 6: Mono Digital Microphone (data is ported to both left and right channels) | 25 |
| Figure 7: Stereo Digital Microphone Configuration | 26 |
| Figure 8: Quad Digital Microphone Configuration | 27 |
| Figure 9: External Volume Control Circuit | 31 |
| Figure 10. Port Configuration | 39 |
| Figure 11. Functional Block Diagram | 40 |
| Figure 12. Widget Diagram | 41 |
| Figure 13. Pin Assignment | 253 |
| Figure 14. 48-pin QFP Package Drawing | 257 |
| Figure 15. Solder Reflow Profile | 258 |

LIST OF TABLES

| | |
|--|-----|
| Table 1. Port Functionality | 13 |
| Table 2. Analog I/O Port Behavior | 14 |
| Table 4. SPDIF OUT 0 (Pin 48) Behavior | 15 |
| Table 5. SPDIF OUT 1 (Pin 40) Behavior | 15 |
| Table 6. Input Multiplexers | 17 |
| Table 7. Function state vs. AFG power state | 17 |
| Table 10. EAPD Behavior | 22 |
| Table 11. Valid Digital Mic Configurations | 24 |
| Table 12. DMIC_CLK and DMIC_0,1 Operation During Power States | 24 |
| Table 13. GPIO Pin mapping | 29 |
| Table 14. Electrical Specification: Maximum Ratings | 32 |
| Table 15. Recommended Operating Conditions | 32 |
| Table 16. 92HD73D 5V, 4.75V, and 3.3V Analog Performance Characteristics | 33 |
| Table 17. High Definition Audio Widget | 42 |
| Table 18. Pin Configuration Default Settings | 43 |
| Table 19. Command Format for Verb with 4-bit Identifier | 45 |
| Table 20. Command Format for Verb with 12-bit Identifier | 45 |
| Table 21. Solicited Response Format | 45 |
| Table 22. Unsolicited Response Format | 45 |
| Table 23. Digital Pins | 254 |
| Table 24. Analog Pins | 254 |
| Table 25. Power Pins | 255 |
| Table 26. Standard Reflow Profile | 258 |
| Table 27. Pb-Free Process Reflow | 259 |

1. DESCRIPTION

1.1. Overview

The 92HD73C is a high fidelity, 6-channel audio codec compatible with the Intel High Definition (HD) Audio Interface. The 92HD73C codec provides high quality, HD Audio capability to desktop and multi-media notebook.

The 92HD73C is designed to meet or exceed premium logo requirements for Microsoft's Windows Logo Program (WLP) 3.09 and revisions 4 as indicated in WLP 3.09.

The 92HD73C provides stereo 24-bit, full duplex resolution supporting sample rates up to 192kHz by the DAC and ADC. 92HD73C SPDIF outputs support sample rates of 192kHz, 176.4kHz, 96kHz, 88.2kHz, 48kHz, and 44.1kHz. 92HD73C SPDIF input supports sample rates of 96kHz, 88.2kHz, 48kHz, and 44.1kHz. Additional sample rates are supported by the driver software.

The 92HD73C supports a wide range of desktop and consumer 8 channel configurations. The 2 independent SPDIF output interfaces provides connectivity to Consumer Electronic equipment like Dolby Digital decoders, powered speakers, mini disk drives or to a home entertainment system. Simultaneous HDMI and SPDIF output is possible.

MIC inputs can be programmed with 0/10/20/30dB boost. For more advanced configurations, the 92HD73C has 8 General Purpose I/O (GPIO).

The port presence detect capabilities allow the codecs to detect when audio devices are connected to the codec. Load impedance sensing helps identify attached peripherals for easy set-up and a better user experience. The fully parametric IDT SoftEQ can be initiated upon headphone jack insertion and removal for protection of notebook speakers.

The 92HD73C operates with a 3.3V digital supply and either 3.3V, or 5V analog supply. It can also work with 1.5V and 3.3V HDA signaling; the correct signalling level is selected dynamically based on the power supply voltage on the DVDD-IO pin.

The 92HD73C1X is available in a 48-pin LQFP Environmental (ROHS) package.

The 92HD73C1T is available in a 48-pin LQFP Environmental (ROHS) INDUSTRIAL Temperature package.

Additional products with the same features as the 92HD73C are the 10-channel 92HD73E and the 8-channel 92HD73D.

1.2. Orderable Part Numbers

| | |
|-------------------|-----------------------------|
| 92HD73C1X5PRGXyyX | 6 channel, 5V, 48QFP |
| 92HD73C1T5PRGIyyX | 6 channel, 5V, 48QFP i-temp |

yy = silicon stepping/revision, contact sales for current data.

Add an "8" to the end for tape and reel delivery. Min/Mult order quantity 2ku.

Contact IDT if interested in 3.3V Analog version.

1.3. Block Diagram

Figure 1. 92HD73C Block Diagram

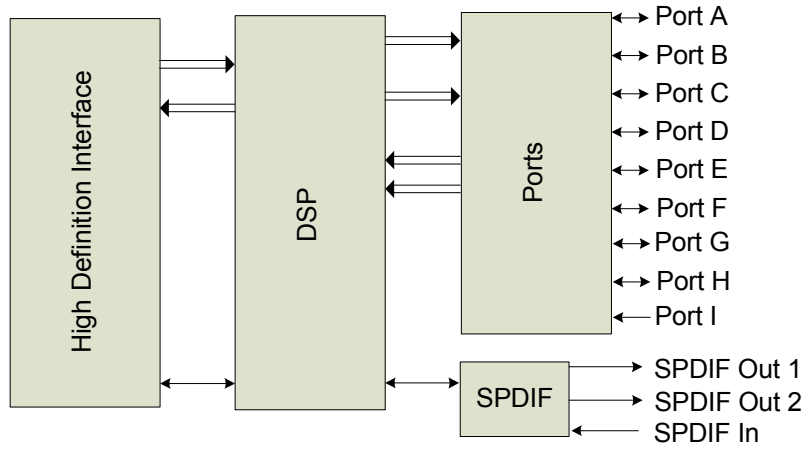
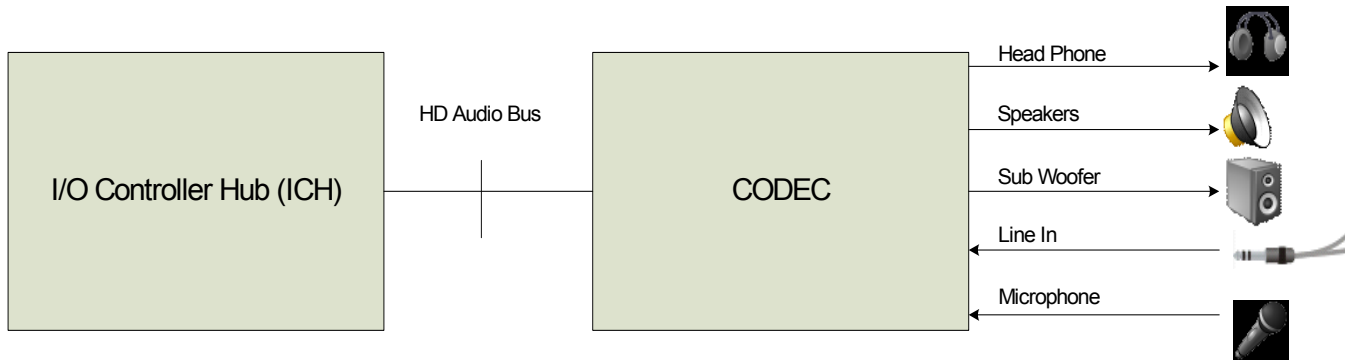

Figure 2. System Diagram



1.4. Detailed Description

1.4.1. Port Functionality

Multi-function (Input / output) ports allow for the highest possible flexibility. 8 bi-directional ports (3 headphone capable) support a wide variety of consumer desktop and mobile system use models.

| Pins | Port | Input | Output | Headphone | Mic Bias (Vref pin) | Input boost amp ¹ | CD (pseudo differential) |
|------------|-------------|-------|--------|-----------|---------------------|------------------------------|--------------------------|
| 39/41 | A | Yes | Yes | Yes | Yes | Yes | |
| 21/22 | B | Yes | Yes | Yes | Yes | Yes | |
| 23/24 | C | Yes | Yes | | Yes | Yes | |
| 35/36 | D | Yes | Yes | Yes | | Yes | |
| 14/15 | E | Yes | Yes | | Yes | Yes | |
| 16/17 | F | Yes | Yes | | | Yes | |
| 43/44 | G | Yes | Yes | | | Yes | |
| 45/46 | H | Yes | Yes | | | Yes | |
| 18/19/20 | CD (Port I) | Yes | | | | | Yes |
| 48 | SPDIF_OUT0 | | Yes | | | | |
| 40 | SPDIF_OUT1 | | Yes | | | | |
| 47 | SPDIF_IN | Yes | | | | | |
| 4 (CLK=2) | DMIC0 | Yes | | | | Yes | |
| 30 (CLK=2) | DMIC1 | Yes | | | | Yes | |

Table 1. Port Functionality

Note¹: 40dB boost requires using the IDT driver. When the 40dB mic boost feature is enabled, additional gain increases greater than 6dB may result in significant audio quality degradation of the microphone audio input. In particular, when the 40dB MIC boost is active, the SNR, THD+N and DC offset will significantly degrade regardless of the input signal level.

1.4.2. Port Characteristics

Universal (Bi-directional) jacks are supported on all ports except the CD input. Ports A, B, and D are designed to drive a set of 32 ohm (nominal) headphones or a 10K (nominal) load with on board shunt resistance as low as 20K ohms (typical - used to maintain coupling CAP bias.) Line Level outputs are intended to drive an external 10K speaker load (nominal) and an on board shunt resistor of 20K-47K (nominal). However, applications may support load impedances of 5K ohms and above. Input ports are 47K (nominal) at the pin.

DAC full scale output and intended full scale input levels are 1V rms. Line output ports and Headphone output ports on 92HD73C may be configured for +3dBV full scale output levels by using a vendor specific verb.

Output ports are always on to prevent pops/clicks associated with charging and discharging output coupling capacitors. This maintains proper bias on output coupling caps even in D3 as long as AVDD is available. Unused ports should be left unconnected. When updating existing designs to use the 92HD73C, ensure that there are no conflicts between the output ports on 92HD73C and existing circuitry.

| AFG Power State | Input Enable | Output Enable | Mute | Port Behavior |
|-----------------|--------------|---------------|------|---|
| D0-D2 | 1 | 1 | - | Not allowed. Port becomes input. |
| | 1 | 0 | - | Active - port enabled as input |
| | 0 | 1 | 0 | Active - port enabled as output |
| | 0 | 1 | 1 | Mute - port enabled as output but drives silence |
| | 0 | 0 | - | Inactive - Port keeps coupling caps charged (same as mute.) |
| D3 | | - | - | Inactive (lower power) - Port keeps output coupling caps charged but consumes less power. |

Table 2. Analog I/O Port Behavior

1.4.3. Jack Detect

Plugs inserted to a jack on Ports A, B, C, & D are detected using SENSE_A. Plugs inserted to a jack on Ports E, F, G, and H are detected using SENSE_B. The following table summarizes the proper resistor tolerances for different analog supply voltages.

SENSE_C, is different from SENSE_A and SENSE_B. Because SENSE_C only determines the presence of a plug for the CD port (port I), SENSE_C is a simple digital input pin referenced to the analog supply. An internal pull-up resistor is provided. No external resistors are needed (jack switch shorts to ground when a plug is inserted.) If external components are added, or if the pin is driven by a logic gate, care should be taken to ensure that the pin voltage is above 70% of AVDD when no plug is in the jack and less than 30% AVDD when a plug is inserted

| AVdd Nominal Voltage (+/- 5%) | Resistor Tolerance SENSE_A (If port D used) | Resistor Tolerance SENSE_A (If port D is not used) | Resistor Tolerance SENSE_B (If port H used) | Resistor Tolerance SENSE_B (If port H is not used) |
|-------------------------------|---|--|---|--|
| 5V | 1% | 1% | 1% | 1% |
| 4.75V | 1% | 1% | 1% | 1% |
| 4V | 0.50% | 1% | 0.50% | 1% |
| 3.3V | 0.10% | 1% | 0.10% | 1% |

Table 3: SENSE Resistor Tolerance

See reference design for more information on Jack Detect implementation.

1.4.4. SPDIF Output

All SPDIF Outputs can operate at 44.1kHz, 48kHz, 88.2kHz, 96kHz, 176.4KHz, and 192KHz as defined in the Intel High Definition Audio Specification with resolutions up to 24 bits. This insures compatibility with all consumer audio gear and allows for convenient integration into home theater systems and media center PCs.

A second independant SPDIF Output is provided as an option for WLP compliant HDMI and SPDIF outputs. Its function is identical to the primary SPDIF output.

Note: Peak to peak jitter is currently limited to less than 4.5nS (half of the internal master clock cycle) which does not meet the IEC-60958-3 0.05UI requirement at 192KHz.

The two SPDIF output converters can not be aligned in phase with the DACs. Even when attached to the same stream, the two SPDIF output converters may be misaligned with respect to their frame boundaries.

SPDIF Outputs on pins 48 and 40 are outlined in tables below. Pin 47 behavior table resides in the EAPD section

| AFG Power State | RESET# | Output Enable | Converter Dig Enable | Stream ID | Pin Behavior |
|-----------------|--------------------|---------------|----------------------|-----------|--|
| D0-D3 | Asserted (Low) | - | - | - | Hi-Z (internal pull-down enabled) immediately after power on, otherwise the previous state is retained until the rising edge of RESET# |
| D0 | De-Asserted (High) | Disabled | - | - | Hi-Z (internal pull-down enabled) |
| | De-Asserted (High) | Enabled | Disabled | - | Active - Pin drives 0 (internal pull-down NA) |
| | De-Asserted (High) | Enabled | Enabled | 0 | Active - Pin drives SPDIF-format, but data is zeroes (internal pull-down NA) |
| | De-Asserted (High) | Enabled | Enabled | 1-15 | Active - Pin drives SPDIFOut0 data (internal pull-down NA) |
| D1-D2 | De-Asserted (High) | Disabled | - | - | Hi-Z (internal pull-down enabled) |
| | De-Asserted (High) | Enabled | - | - | Active - Pin drives 0 (internal pull-down NA) |
| D3 | De-Asserted (High) | - | - | - | Hi-Z (internal pull-down enabled) |

Table 4. SPDIF OUT 0 (Pin 48) Behavior

| AFG Power State | RESET# | GPIO 3 Enable | Output Enable | Converter Dig Enable | Stream ID | Pin Behavior |
|-----------------|--------------------|---------------|---------------|----------------------|-----------|--|
| D0-D3 | Asserted (Low) | - | - | - | - | Hi-Z (internal pull-down enabled) immediately after power on, otherwise the previous state is retained until the rising edge of RESET# |
| D0-D3 | De-Asserted (High) | Enabled | - | - | - | Active - Pin reflects GPIO7 configuration (internal pull-up enabled) |

Table 5. SPDIF OUT 1 (Pin 40) Behavior

| AFG Power State | RESET# | GPIO 3 Enable | Output Enable | Converter Dig Enable | Stream ID | Pin Behavior |
|-----------------|--------------------|---------------|---------------|----------------------|-----------|---|
| D0 | De-Asserted (High) | Disabled | Disabled | - | - | Hi-Z (internal pull-down enabled) |
| | De-Asserted (High) | Disabled | Enabled | Disabled | - | Active - Pin drives 0 (internal pull-down enabled) |
| | De-Asserted (High) | Disabled | Enabled | Enabled | 0 | Active - Pin drives SPDIF-format, but data is zeroes (internal pull-down enabled) |
| | De-Asserted (High) | Disabled | Enabled | Enabled | 1-15 | Active - Pin drives SPDIFOut1 data (internal pull-down enabled) |
| D1-D2 | De-Asserted (High) | Disabled | Disabled | - | - | Hi-Z (internal pull-down enabled) |
| | De-Asserted (High) | Disabled | Enabled | - | - | Active - Pin drives 0 (internal pull-down NA) |
| D3 | De-Asserted (High) | Disabled | - | - | - | Hi-Z (internal pull-down enabled) |

Table 5. SPDIF OUT 1 (Pin 40) Behavior

1.4.5. SPDIF Input

SPDIF IN can operate at 44.1 KHz, 48 KHz, 88.2 KHz or 96 KHz, and implements internal Jack Sensing.

A sophisticated digital PLL allows automatic rate detection and accurate data recovery. The ability to directly accept consumer SPDIF voltage levels eliminates the need for costly external receiver ICs. Advanced features such as record-slot-select and SPDIF_IN routing to the DAC allow for simultaneous record and play.

1.4.6. Analog Mixer

An analog mixer is available on the 92HD73C. The mixer supports independent gain (-34.5 to +12dB in 1.5dB steps) on each input as well as independent mutes on each input. A master volume follows mixing and provides gain from -46.5dB to 0dB in 1.5dB steps.

The following inputs are available:

- CD
- Analog PC_Beep
- Inport0_Mux
- Inport1_Mux
- Inport2_Mux
- Inport3_mux

1.4.7. Input Multiplexers

92HD73C implements 4 port input multiplexers. These multiplexers allow a preselection of one of four possible inputs:

| Inport0_Mux | Inport1_Mux | Inport2_Mux | Inport3_mux |
|-------------|-------------|-------------|-------------|
| Port A | Port A | Port B | DAC 0 |
| Port B | Port E | Port C | DAC 1 |
| Port D | Port G | Port G | DAC 2 |
| Port F | Port H | Port H | DAC 3 |

Table 6. Input Multiplexers

1.4.8. ADC Multiplexers

92HD73C implements 2 ADC input multiplexers. These multiplexers incorporate the ADC record gain function (0 to +22.5dB gain in 1.5dB steps) as an output amp and allow a preselection of one of 12 possible inputs:

- DMIC 0
- DMIC 1
- Mixer output
- CD input
- Ports A - H

1.4.9. Power Management

The HD Audio specification defines power states, power state widgets, and power state verbs. Power management is implemented at several levels. The Audio Function Group (AFG) and all converter widgets support the power state verb F05/705 (as well as the pin widget associated with pin 47.) Converter widgets are active in D0 and inactive in D1-D3.

The following table describes what functionality is active in each power state supported by the AFG.

| Function | D0 | D1 ¹ | D2 | D3 | vendor specific |
|---------------------------|----|-----------------|-----|-----|-----------------|
| SPDIF Outputs | On | Off | Off | Off | - |
| SPDIF Inputs | On | Off | Off | Off | - |
| Digital Microphone inputs | On | Off | Off | Off | - |
| DAC | On | Off | Off | Off | - |
| D2S | On | Off | Off | Off | - |
| ADC | On | Off | Off | Off | - |
| ADC Volume Control | On | Off | Off | Off | - |
| Ref ADC | On | Off | Off | Off | - |
| Analog Clocks | On | Off | Off | Off | - |
| GPIO pins | On | On | On | On | - |
| VrefOut Pins | On | On | Off | Off | - |

Table 7. Function state vs. AFG power state

| Function | D0 | D1 ¹ | D2 | D3 | vendor specific |
|--------------------------|----|-----------------|-----|------------------------|---------------------------|
| Input Boost | On | On | Off | Off | - |
| Analog mixer | On | On | Off | Off | - |
| Mixer Volumes | On | On | Off | Off | |
| Analog PC_Beep | On | On | Off | Off | |
| Digital PC_Beep | On | On | On | On | - |
| Lo Amp | On | On | On | Low Drive ² | Programmable |
| HP Amps | On | On | On | Low Drive ² | Programmable |
| VAG amp | On | On | On | Low Drive ³ | Programmable |
| Port Sense | On | On | On | On ⁴ | Programmable |
| Reference Bias generator | On | On | On | On | Programmable ⁵ |
| Reference Bandgap core | On | On | On | On | Programmable ⁵ |
| HD Audio-Link | On | On | On | On ⁶ | - |

Table 7. Function state vs. AFG power state

- 1.No DAC or ADC streams are active. Analog mixing and loop thru are supported.
- 2.VAG is kept active when ports are disabled or in D2/D3. Ports may be powered down using vendor specific verbs.
- 3.VAG is always ramped up and down gradually, except in the case of a sudden power removal. VAG is active in D2/D3 but in a low power state.
4. BITCLK must be active and both AVDD and DVDD must be available for Port Sense to operate.
- 5.Vendor specific bit for Ref Top controls VAG generator, Bandgap Reference, and Reference bias generator. Place part into D3 and power down all ports (using vendor specific verbs) before powering down Ref Top.
- 6.Obviously not active if BITCLK is not running (Controller in D3).

1.4.9.1. AFG D0

The AFG D0 state is the active state for the device. All functions are active if their power state (if they support power management at their node level) has been set to D0.

1.4.9.2. AFG D1

D1 is a lower power mode where all converter widgets are disabled. Analog mixer and port functions are active.

1.4.9.3. AFG D2

The D2 state further reduces power by disabling the mixer and port functions. The port amplifiers and internal references remain active to keep port coupling caps charged and the system ready for a quick resume to either the D1 or D0 state.

1.4.9.4. AFG D3

The D3-default state is available for HD Audio compliance. All converters are shut down. Port amplifiers and references are active but in a low power state to prevent pops. Resume times may be longer than those from D2, but still very fast to meet Intel low power goals.

The traditional use for D3 was as a transitional state before power was removed (D3 cold) before the system entered into standby, hibernate, or shut-down. To conserve power, Intel now promotes using D3 whenever there are no active streams or other activity that requires the part to consume full power. The system remains in S0 during this time. When a stream request or user activity requires

the CODEC to become active, the driver will immediately transition the CODEC from D3 to D0. To enable this use model, the CODEC must resume within 10mS and not pop.

The default power state for the Audio Function Group after reset is D3-default

1.4.9.5. AFG D3 and vendor specific verbs

The programmable values, exposed via vendor-specific settings, are under the IDT Device Driver control for further power reduction.

1.4.10. Low-voltage HDA Signaling

The 92HD73C is compatible with either 1.5V or 3.3V HDA bus signaling; the voltage selection is done dynamically based on the input voltage of DVDD_IO.

When in 1.5V mode, the 92HD73C can correctly decode BITCLK, SYNC, RESET# and SDO as they operate at 1.5V; additionally it will drive SDI and SDO at 1.5V. None of the GPIOs are affected, as they always function at their nominal voltage (DVDD or AVDD).

1.4.11. Multi-channel capture

The capability to assign multiple ADC “Input Converters” to the same stream is supported to meet the microphone array requirements of Vista and future operating systems. Single converter streams are still supported and is done by assigning unique non zero Stream IDs to each converter. All capture devices (ADCs 0 and 1) may be used to create a multi-channel input stream. There are no restrictions regarding digital microphones. However, the SPDIF input can not be used with an ADC to create a 4-channel stream. SPDIF_In only supports stereo capture.

The ADC Converters can be associated with a single stream as long as the sample rate and the bits per sample are the same. The assignment of converter to channel is done using the “CnvtrID” widget and is restricted to even values. The ADC converters will always put out a stereo sample and therefore require 2 channels per converter.

The stream will not be generated unless all entries for the targeted converters are set identically, and the total number of assigned converter channels matches the value in the NnbrChan field. These are listed the “Multi-Converter Stream Critical Entries” table.

An example of a 4 Channel Steam with ADC0 supplying channels 0&1 and ADC1 supplying channels 2&3 is shown below. A 4 Channel stream can be created by assigning the same non-zero stream id “Strm= N” to both ADC0 and ADC1. The sample rates must be set the same and the number of channels must be set to 4 channels “NnbrChan = 0011”.

| | | |
|--------------|--------------|--------|
| ADC1 CnvtrID | (NID = 0x08) | |
| | [3:0] | Ch = 2 |
| ADC0 CnvtrID | (NID = 0x07) | |
| | [3:0] | Ch = 0 |

Table 8: Example channel mapping

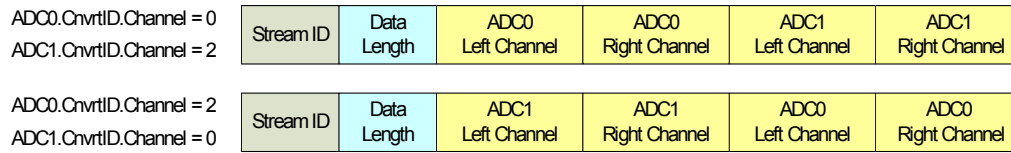

Figure 3. Multi-channel capture

The following figure describes the bus waveform for a 24-bit, 48KHz capture stream with ID set to 1.

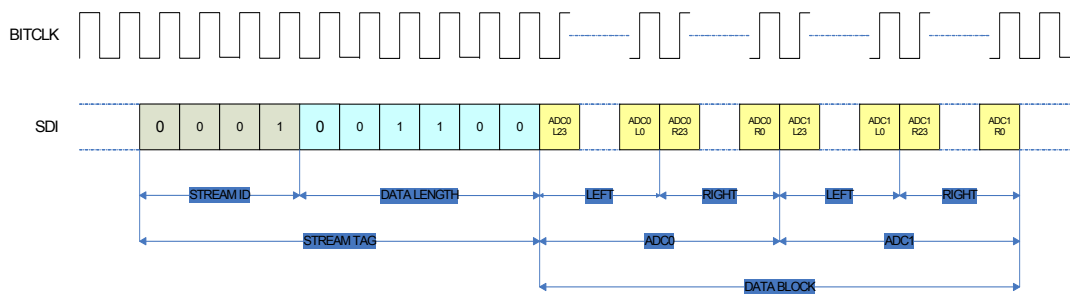

Figure 4. Multi-channel timing diagram

| ADC[1:0] Cnvr | Bit Number | Sub Field Name | Description |
|---------------|------------|----------------|--|
| | [15] | StrmType | Stream Type (TYPE): 0: PCM 1: Non-PCM (not supported) |
| | [14] | FrmtSmplRate | Sample Base Rate 0= 48kHz 1=44.1KHz |
| | [13:11] | SmplRateMultp | Sample Base Rate Multiple 000=48kHz/44.1kHz or less 001= x2 010= x3 (not supported) 011= x4 100-111= Reserved |

Table 9: Multi-Converter Stream Critical Entries.

| | | | |
|-------------------------|-------------------|-----------------------|--|
| | [10:8] | SmplRateDiv | Sample Base Rate Divisor 000= Divide by 1 001= Divide by 2 (not supported) 010= Divide by 3 (not supported) 011= Divide by 4 (not supported) 100= Divide by 5 (not supported) 101= Divide by 6 (not supported) 110= Divide by 7 (not supported) 111= Divide by 8 (not supported) |
| | [6:4] | BitsPerSmpl | Bits per Sample 000= 8 bits (not supported) 001= 16 bits 010= 20 bits 011= 24 bits 100-111= Reserved |
| | [3:0] | NmbrChan | Number of Channels Number of channels for this stream in each “sample block” of the “packets” in each “frame” on the link. 0000=1 channel (not supported) 0001 = 2 channels ... 1111= 16 channels. |
| ADC[1:0] CnvtrID | Bit Number | Sub Field Name | Description |
| | [7:4] | Strm | Software-programmable integer representing link stream ID used by the converter widget. By convention stream 0 is reserved as unused. |
| | [3:0] | Ch | Integer representing lowest channel used by converter. 0 and 2 are valid Entries If assigned to the same stream, one ADC must be assigned a value of 0 and the other ADC assigned a value of 2. |

Table 9: Multi-Converter Stream Critical Entries.

1.4.12. EAPD

The EAPD pin (pin 47) also supports SPDIF_In and GPIO functions. The pin defaults to EAPD after power on reset and will remain in EAPD mode until either GPIO is enabled for pin 47 or the port I/O is enabled to support SPDIF. Although named External Amplifier Power Down (EAPD) by the HD Audio specification, this pin operates as an external amplifier power up signal. The EAPD value is reflected on the EAPD pin; a 1 causes the external amplifier to power up, and a 0 causes it to power down. When the EAPD value = 1, the EAPD pin must be placed in a state appropriate to the current power state of the associated Pin Widget even though the EAPD value may remain 1. The default state of this pin is 0 (driving low) and a Pull-down prevents the line from floating high when the part is in reset.

| AFG Power State | RESET# | GPIO Enable | Input Enable | EAPD Power State | Pin Behavior |
|-----------------|--------------------|-------------|--------------|------------------|--|
| D0-D3 | Asserted (Low) | - | - | - | Hi-Z (internal pull-down enabled) immediately after power on, otherwise the previous state is retained until the rising edge of RESET# |
| D0 | De-Asserted (High) | Enabled | - | - | Active - Pin reflects GPIO0 configuration (internal pull-up enabled) |
| | De-Asserted (High) | Disabled | Enabled | - | Active - Pin is SPDIF_In |
| | De-Asserted (High) | Disabled | Disabled | D0-D1 | Active - Pin drives the value of the EAPD bit (internal pull-down enabled) |
| | De-Asserted (High) | Disabled | Disabled | D2-D3 | Hi-Z (internal pull-down enabled) |
| D1 | De-Asserted (High) | Disabled | Enabled | - | Inactive - Pin configured as input, but SPDIF_In idle. |
| | De-Asserted (High) | Disabled | Disabled | D0-D1 | Active - Pin drives the value of the EAPD bit (internal pull-down enabled) |
| | De-Asserted (High) | Disabled | Disabled | D2-D3 | Hi-Z (internal pull-down enabled) |
| D2 | De-Asserted (High) | Disabled | - | D0-D3 | Hi-Z (internal pull-down enabled) |
| D3 | De-Asserted (High) | Disabled | - | D0-D3 | Hi-Z (internal pull-down enabled) |

Table 10. EAPD Behavior

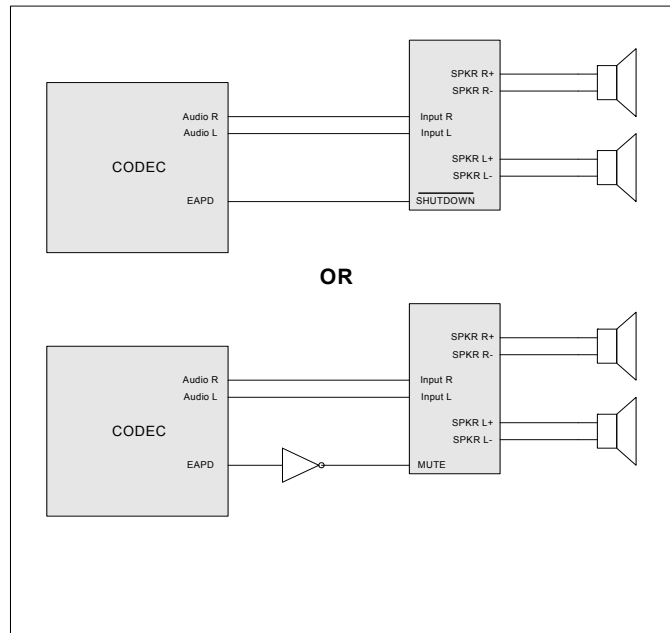

Figure 5. EAPD

1.4.13. Digital Microphone Support

The digital microphone interface permits connection of a digital microphone(s) to the CODEC via the DMIC0, DMIC1, and DMIC_CLK 3-pin interface. The DMIC0 and DMIC1 signals are inputs that carry individual channels of digital Mic data to the ADC. In the event that a single microphone is used, the data is ported to both ADC channels.

The DMIC_CLK output is controllable from 4.704Mhz, 3.528Mhz, 2.352Mhz, 1.176Mhz and is synchronous to the 24Mhz internal clock. The default frequency is 2.352Mhz.

The two DMIC data inputs are reported as two stereo input pin widgets that incorporate a boost amplifier. The pin widgets are shown connected to the ADCs through the same multiplexors as the analog ports. Although the internal implementation is different between the analog ports and the digital microphones, the functionality is the same. In most cases, the default values for the DMIC clock rate and data sample phase will be appropriate and an audio driver will be able to configure and use the digital microphones exactly like an analog microphone.

92HD73C supports the following digital microphone configurations:

| Digital Mics | Data Sample | ADC Conn. | Notes |
|--------------|--|-----------|--|
| 0 | N/A | N/A | No Digital Microphones |
| 1 | Single Edge | 0, or 1 | Available on either DMIC_0 or DMIC_1 Both ADC Channels produce data, may be in phase or out by 1/2 DMIC_CLK period depending upon external configuration and timing |
| 2 | Double Edge on either DMIC_0 or 1 OR Single Edge on DMIC_0 and 1 | 0, or 1 | Available on either DMIC_0 or DMIC_1, External logic required to support sampling on a single Digital Mic pin channel on rising edge and second Digital Mic right channel on falling edge of DMIC_CLK for those digital microphones that don't support alternative clock edge capability. If both DMIC_0 and DMIC_1 are used to support 2 digital microphones, 2 separate ADC units will be used, however, this configuration is not recommended since it consumes two stereo ADC resources. |
| 3 | Double Edge on one DMIC pin and Single Edge on the second DMIC pin. | 0, or 1 | Requires both DMIC_0 or DMIC_1, External logic required to support sampling on a single Digital Mic pin channel on rising edge and second Digital Mic right channel on falling edge of DMIC_CLK for those digital microphones that don't support alternative clock edge capability. Two ADC units are required to support this configuration |
| 4 | Double Edge | 0, or 1 | Connected to DMIC_0 and DMIC_1, External logic required to support sampling on a single Digital Mic pin channel on rising edge and second Digital Mic right channel on falling edge of DMIC_CLK for those digital microphones that don't support alternative clock edge capability. Two ADC units are required to support this configuration |

Table 11. Valid Digital Mic Configurations

| Power State | DMIC Widget Enabled | DMIC_CLK Output | DMIC_0,1 | Notes |
|-------------|---------------------|-----------------|----------------|--|
| D0 | Yes | Clock Capable | Input Capable | DMIC_CLK Output is Enabled when either DMIC_0 or DMIC_1 Input Widget is Enabled. Otherwise, the DMIC_CLK remains Low |
| D1-D3 | Yes | Clock Disabled | Input Disabled | DMIC_CLK is HIGH-Z with Weak Pull-down |
| D0-D3 | No | Clock Disabled | Input Disabled | DMIC_CLK is HIGH-Z with Weak Pull-down |

Table 12. DMIC_CLK and DMIC_0,1 Operation During Power States



Figure 6: Mono Digital Microphone (data is ported to both left and right channels)

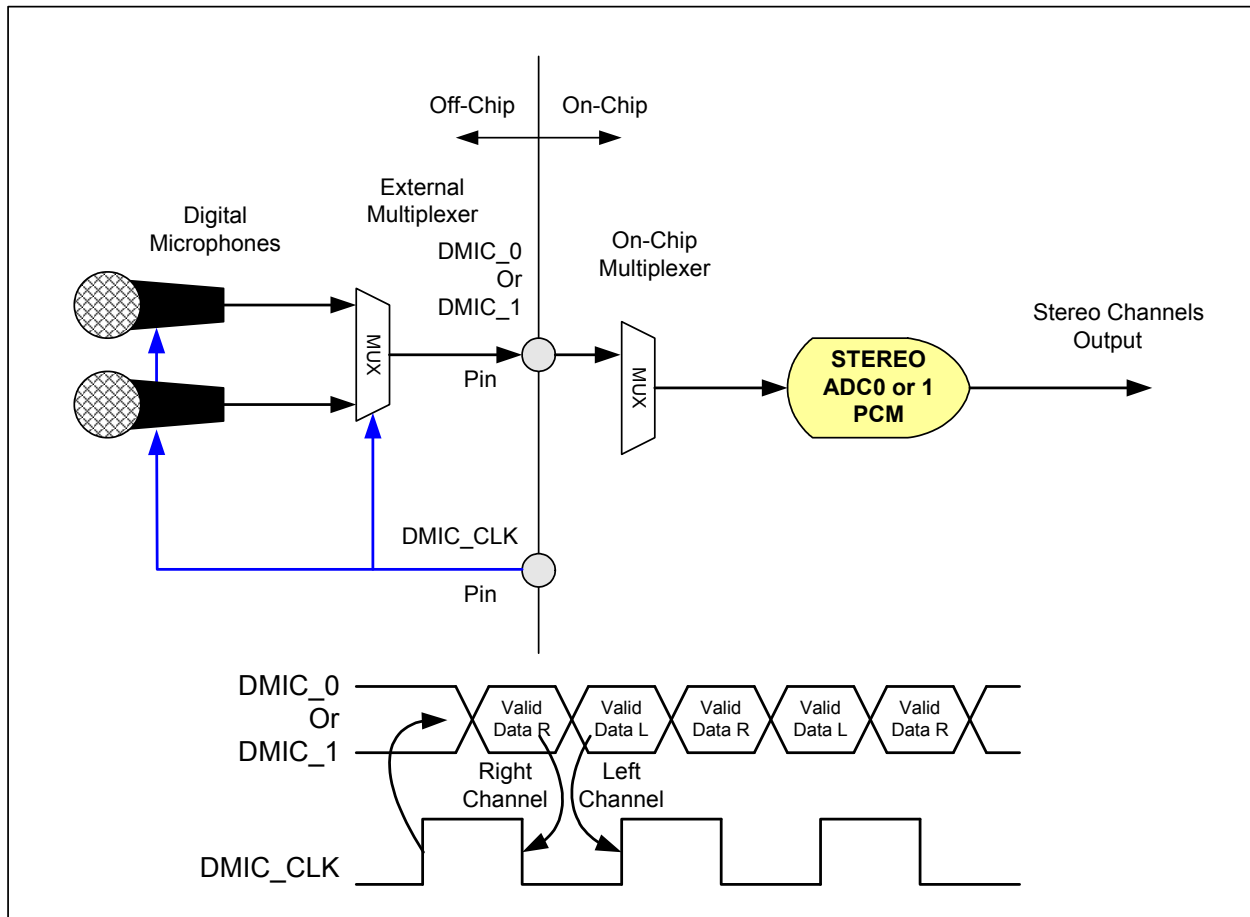

Figure 7: Stereo Digital Microphone Configuration

Note: Some Digital Microphone Implementations support data on either edge, therefore, the external mux may not be required.



Figure 8: Quad Digital Microphone Configuration

Note: Some Digital Microphone Implementations support data on either edge, therefore, the external mux may not be required.

1.4.14. PC-Beep

92HD73C supports both analog and digital PC_Beep functions.

1.4.14.1. Analog PC-Beep

92HD73C does not support automatic routing of the PC_Beep pin to all outputs when the link is in reset. Analog PC-Beep may be supported during Link Reset if the mixer is manually configured for pass-thru. Otherwise, Reset# must be high and Bit_Clk active.

The default values for the vendor specific verb (7EE/FEE in AFG) associated with Analog PC-Beep are:

- Enable = 0h (Analog PC-Beep disabled - mute)
- volume = 3h (0dB)

Analog PC-Beep is supported in D3, but may be attenuated or distorted depending on the load-impedance on the port. Line outputs can drive 10K ohm loads in D3 at 1Vrms, but will be current limited when driving lower impedance loads. Enabling or disabling analog PC-Beep may cause a click or pop sound.

1.4.14.2. Digital PC-Beep

This block uses an 8-bit divider value to generate the PC beep from the 48kHz Azalia sync pulse. The digital PC_Beep block generates the beep tone on all Pin Complexes that are currently configured as outputs. The HD Audio spec states that the beep tone frequency = (48kHz HD Audio SYNC rate) / (4*Divider), producing tones from 47 Hz to 12 kHz (logarithmic scale). Other audio sources are disabled when digital PC_Beep is active.

It should be noted that digital PC Beep is disabled if the divider = 00h.

1.4.15. Headphone Drivers

This product implements a +3dBV output option on headphone capable ports. (HP output and line output levels are defined as 1Vrms at this time with an option to enable +3dBV FSOV using a vendor specific verb.) The Microsoft Windows Logo Program allows up to the equivalent of 100ohms in series. However, an output level of +3dBV at the pin is required to support 300mV at the jack with a 32ohm load and 1V with a 320 ohm load. Microsoft allows device and system manufactures to limit output voltages to address EU safety requirements. (WLP 3.09 - please refer to the latest Windows Logo Program requirements from Microsoft.) 92HD73C, however, requires external components (series resistors) to limit the output voltage to 150mV with a 32 ohm load or secure software limiting by restricting DAC and mixer gain ranges.

Although 3 Headphone amplifiers are present, only two may be used simultaneously.

Performance will degrade when driving more than one set of headphones. Only one set of headphones (32 ohm nominal) may be connected to a headphone capable port.

1.4.16. GPIO

1.4.16.1. GPIO Pin mapping and shared functions.

| GPIO # | Pin | Supply | SPDIF In | SPDIF Out | GPI/O | GPI | GPO | VrefOut | DMIC | VOL | Pull Up | Pull Down |
|--------|-----|--------|----------|-----------|-------|-----|-----|---------|------|-----|------------------|-------------------------------|
| 0 | 47 | DVDD | YES | | YES | | | | | | 50K (GPIO) | 50K ¹ (SPDIF/EAPD) |
| 1 | 2 | DVDD | | | YES | | | | CLK | YES | 50K (GPIO/VOL) | 50K (DMIC) |
| 2 | 4 | DVDD | | | YES | | | | IN | YES | 50K (GPIO/VOL) | 50K (DMIC) |
| 3 | 40 | AVDD | | YES | YES | | | | | | 50K (GPIO) | 50K ¹ (SPDIF) |
| 4 | 29 | AVDD | | | YES | | | YES | | | | |
| 5 | 30 | AVDD | | | YES | | | | IN | | 50K ¹ | 50K (DMIC) |
| 6 | 31 | AVDD | | | YES | | | YES | | | | |
| 7 | 37 | AVDD | | | YES | | | YES | | | | |

Table 13. GPIO Pin mapping

1.Default condition.

1.4.16.2. Volume/Digital Microphone/GPIO Selection

There are 3 functions available on pins 2 and 4. To determine which function is actually enabled on the 2 pins, the order of precedence is followed:

1. If the GPIOs are enabled, they override both Volume Control and Digital Mics
2. If the GPIOs are not enabled through the AFG, then at reset, the Volume control is enabled with the weak pull-up.
3. If BIOS or other software application enables either Digital Microphones inputs through the Configuration Default Register, the Volume is disconnected and the pull-ups are disconnected with the weak pull-downs enabled.

1.4.16.3. VRefOut/GPIO Selection

Two functions are available on pins 29, 31, and 37. To determine which function is actually enabled, the order of precedence is followed:

1. If the GPIOx function is enabled, it overrides VRefOut-X
2. If the GPIO function is not enabled through the AFG, then the VrefOut function is enabled and in its default state.
3. If using a VrefOut pin as GPIO, make sure to incorporate a 10K ohm external pull-up to AVDD to prevent the pin from floating in GPI mode and to allow proper operation in open-drain GPO mode.

1.4.17. External Volume Control

92HD73C incorporates a 2-pin volume control interface. Volume up, down, and mute functions are easily implemented using 2 push-button switches. The CODEC provides internal pull-up resistors simplifying external CODEC circuitry. Also, repeat and direct modes of operation add flexibility to the interface. The typical usage model is for front panel master volume buttons on an entertainment PC, or case mounted hardware volume control for mobile platforms.

1.4.17.1. Theory of Operation

The codec monitors the volume up/down inputs for a change of state from high to low, and waits for the inputs to settle. If the inputs have not settled by the end of the de-bounce period, then the value at the end of the period is used. A 0 (low voltage) on the Down pin will decrement the volume register, while a 0 on the Up pin will increment the volume register. If both inputs are 0 at the same time, then the volume register will be set to its lowest value (mute). Pressing Up, Down, or both buttons at the same time when the volume control interface is in mute mode, will cause the part to un-mute.

The de-bounce / repeat rate is selectable from 2.5Hz to 20Hz in 2.5Hz increments using the Volume Knob VCSR0 verb (FE0) Rate bits (bits 2:0). This value is used for both de-bounce and repeat rates. The de-bounce period is the time that the CODEC waits for the inputs to settle, and the repeat rate is the rate at which the CODEC will increment/decrement the volume if a volume button is pushed and held. When a falling edge is detected on either one of the volume control pins, the codec will wait for (1/Rate) seconds for the input to settle. If the Continuous bit is set in the Volume Knob VCSR0 verb (bit 3), then the codec will wait for the de-bounce period to expire then repeatedly increment or decrement the volume register at the rate specified in the Rate bits until the button is released.

1.4.17.2. Modes of Operation

- DIRECT MODE

In Direct mode, the Volume Knob widget directly controls the volume of all of the DACs in the part. The volume in the Volume Knob widget acts as the master volume and limits the maximum volume for each of the DAC amplifiers. The amp gain for each of the DACs can also be adjusted using the DAC amplifiers. However, the actual gain for an individual DAC will be the sum of the Volume Knob volume and the DAC amplifier volume. For example, if the DAC amplifier gain is set to 0x7F (0dB) and the Volume Knob volume is set to 0x3F (-48dB) the resulting gain would be -48dB. If the combination of gains is less than -95.25dB (the equivalent to a value of 0x0 for the DAC or Volume Knob volume settings) then the actual gain will be -95.25dB. For example, if the Volume Knob is set to 0x3F (-48dB) and the DAC amplifier volume is set to 0x1F (-72dB) then the DAC volume will be set to -95.25dB.

Direct mode is enabled by setting bit 7 in the Volume Knob Cntrl verb (F0F). The volume is reflected in the Volume Knob Cntrl bits 6:0 and the step size is 0.75dB. In direct mode, software can read or write the volume in the Volume Knob widget.

- INDIRECT MODE

In indirect mode, the Volume Knob widget does not directly control the DAC amplifier gains. An event on the volume Up/Down pins will increment/decrement the value in the Volume Knob Cntrl verb (F0F) volume bits (bits 6:0) just as in Direct mode. However, instead of adjusting the DAC amplifier gain, an unsolicited response is generated (if enabled) and the control software must read

the volume in the Volume Knob widget and take appropriate action. Indirect mode is particularly useful when it is undesirable to control all of the DAC amplifier volumes at the same time, or when implementing ADC volume control.

In indirect mode, there are only 128 volume levels in the Volume Knob Cntrl volume bits, the value will not go beyond the lower and upper limits (0x0 or 0x7F), and an unsolicited response will be generated if an input event tries to go beyond these limits. Therefore, it is the responsibility of the controlling software to monitor the volume in the Volume Knob Widget and take appropriate action.

Indirect mode is enabled by clearing bit 7 in the Volume Knob Cntrl verb (F0F). The volume is reflected in the Volume Knob Cntrl bits 6:0 and the step size is 0.75dB. In direct mode, software can read or write the volume in the Volume Knob widget.

1.4.17.3. Hardware Implementation

The Volume Knob interface is comprised of two input pins, CODEC pins 2 and 4. Both pins have internal pull-up resistors, so only two push button switches are required for most implementations. Typically, a series resistor and shunt capacitor are used to help reduce noise and prevent damage from ESD and other potential faults. An example circuit is shown below in below.



Figure 9: External Volume Control Circuit

2. CHARACTERISTICS

2.1. Electrical Specifications

2.1.1. Absolute Maximum Ratings

Stresses above the ratings listed below can cause permanent damage to the 92HD73C. These ratings, which are standard values for IDT commercially rated parts, are stress ratings only. Functional operation of the device at these or any other conditions above those indicated in the operational sections of the specifications is not implied. Exposure to absolute maximum rating conditions for extended periods can affect product reliability. Electrical parameters are guaranteed only over the recommended operating temperature range.

Table 14. Electrical Specification: Maximum Ratings

| Item | Pin | Maximum Rating |
|---------------------------------------|------|---|
| Analog maximum supply voltage | AVdd | 6 Volts |
| Digital maximum supply voltage | DVdd | 5.5 Volts |
| VREFOUT output current | | 5 mA |
| Voltage on any pin relative to ground | | Vss - 0.3 V to Vdd + 0.3 V |
| Operating temperature | | 0 °C to +70 °C -40°C to +85 °C (INDUSTRIAL TEMP) |
| Storage temperature | | -55 °C to +125 °C |
| Soldering temperature | | Soldering temperature information for all available in the package section of this datasheet. |

2.1.2. Recommended Operating Conditions

Table 15. Recommended Operating Conditions

| Parameter | | Min. | Typ. | Max. | Units |
|---|------------------------------|-------|------|-------|-------|
| Power Supply Voltage | Digital - 3.3 V | 3.135 | 3.3 | 3.465 | V |
| | Analog - 3.3 V | 3.135 | 3.3 | 3.465 | V |
| (Note: With Supply Override Enable Bit set to force 5 V operation.) | Analog - 4 V | 3.8 | 4 | 4.2 | V |
| | Analog - 4.5 V | 4.51 | 4.75 | 4.99 | V |
| | Analog - 5 V | 4.75 | 5 | 5.25 | V |
| Ambient Operating Temperature | | 0 | | +70 | °C |
| Case Temperature | T _{case} Commercial | | | +90 | °C |
| | T _{case} Industrial | | | +110 | °C |

ESD: The 92HD73C is an ESD (electrostatic discharge) sensitive device. The human body and test equipment can accumulate and discharge electrostatic charges up to 4000 Volts without detection. Even though the 92HD73C implements internal ESD protection circuitry, proper ESD precautions should be followed to avoid damaging the functionality or performance.

2.2. 92HD73C 5V, 4.75V, and 3.3V Analog Performance Characteristics

(Tambient = 25 °C, AVdd = Supply ± 5%, DVdd = 3.3V ± 5%, AVss=DVss=0V; 20Hz to 20KHz swept sinusoidal input; Sample Frequency = 48 kHz; 0 dB = 1 VRMS, 10KΩ//50pF load, Testbench Characterization BW: 20 Hz – 20 kHz, 0 dB settings on all gain stages)

| Parameter | Conditions | AVdd | Min | Typ | Max | Unit |
|--|--|---------------------|----------------|----------------|-----|------|
| Digital to Analog Converters | | | | | | |
| Resolution | | All | | 24 | | Bits |
| Dynamic Range ¹ : PCM to All Analog Outputs | -60dB FS signal level | 5V 4.75V 3.3V | 90 90 85 | 94 94 88 | | dB |
| SNR ² - DAC to All Line-Out Ports | Analog Mixer Disabled, PCM data | 5V 4.75V 3.3V | 90 90 85 | 97 97 88 | | dB |
| THD+N ³ - DAC to All Line-Out Ports | Analog Mixer Disabled, 0dB FS Signal, PCM data | 5V 4.75V 3.3V | 80 80 80 | 83 83 83 | | dBr |
| THD+N ³ - DAC to All Line-Out Ports | Analog Mixer Disabled, -1dB FS Signal, PCM data | 5V 4.75V 3.3V | 80 80 80 | 83 83 83 | | dBr |
| SNR ² - DAC to All Headphone Ports | Analog Mixer Disabled, 10KΩ load, PCM data | 5V 4.75V 3.3V | 90 90 85 | 97 97 88 | | dB |
| THD+N ³ - DAC to All Headphone Ports | Analog Mixer Disabled, 0dB FS Signal, 10KΩ load, PCM data | 5V 4.75V 3.3V | 80 80 80 | 83 83 83 | | dBr |
| THD+N ³ - DAC to All Headphone Ports | Analog Mixer Disabled, -1dB FS Signal, 10KΩ load, PCM data | 5V 4.75V 3.3V | 80 80 80 | 83 83 83 | | dBr |
| SNR ² - DAC to All Headphone Ports | Analog Mixer Disabled, 32Ω load, PCM data | 5V 4.75V 3.3V | 90 90 85 | 97 97 88 | | dB |
| THD+N ³ - DAC to All Headphone Ports | Analog Mixer Disabled, 0dB FS Signal, 32Ω load, PCM data | 5V 4.75V 3.3V | 65 65 65 | 70 70 70 | | dBr |

Table 16. 92HD73C 5V, 4.75V, and 3.3V Analog Performance Characteristics

| Parameter | Conditions | AVdd | Min | Typ | Max | Unit |
|---|---|---------------------|-----------------------|-----------------------|--------|-----------|
| THD+N ³ - DAC to All Headphone Ports | Analog Mixer Disabled, -1dB FS Signal, 32Ω load, PCM data | 5V 4.75V 3.3V | 65 65 65 | 70 70 70 | | dBr |
| Any Analog Input (ADC) to DAC Crosstalk | 10KHz Signal Frequency. 0dBV signal applied to ADC, DACs idle, ports enabled as output. | All | - | -80 | - | dB |
| Any Analog Input (ADC) to DAC Crosstalk | 1KHz Signal Frequency see above | All | - | -85 | - | dB |
| DAC L/R crosstalk | DAC to LO or HP 20-15KHz into 10KΩ load | All | 65 | 70 | | dB |
| DAC L/R crosstalk | DAC to HP 20-15KHz into 32Ω load | All | 65 | 70 | | dB |
| Gain Error | Analog Mixer Disabled | All | | | 0.5 | dB |
| Interchannel Gain Mismatch | Analog Mixer Disabled | All | | | 0.5 | dB |
| D/A Digital Filter Pass Band ⁴ | | All | 20 | - | 21,000 | Hz |
| D/A Digital Filter Transition Band | | All | 21,000 | - | 31,000 | Hz |
| D/A Digital Filter Stop Band | | All | 31,000 | - | - | Hz |
| D/A Digital Filter Stop Band Rejection ⁵ | | All | -100 | - | - | dB |
| D/A Out-of-Band Rejection ⁶ | | All | -55 | - | - | dB |
| Group Delay (48KHz sample rate) | | All | - | - | 1 | ms |
| Attenuation, Gain Step Size DIGITAL | | All | - | 0.75 | - | dB |
| DAC Offset Voltage | | All | - | 10 | 20 | mV |
| Deviation from Linear Phase | | All | - | 1 | 10 | deg. |
| Analog Outputs | | | | | | |
| Full Scale All Line-Outs | DAC PCM Data | 5V 4.75V 3.3V | 1.00 1.00 0.707 | 1.07 1.07 0.758 | - | Vrms |
| Full Scale All Line-Outs | DAC PCM Data | 5V 4.75V 3.3V | 2.83 2.83 2.00 | 3.03 3.03 2.14 | - | Vp-p |
| All Headphone Capable Outputs | 32Ω load | 5V 4.75V 3.3V | 40 40 31 | 60 60 42 | - | mW (peak) |
| Amplifier output impedance | Line Outputs Headphone Outputs | All | | 150 0.1 | | Ohms |
| Analog inputs | | | | | | |
| Full Scale Input Voltage | 0dB Boost @4.75V (input voltage required for 0dB FS output) | 5V 4.75V 3.3V | 1.05 | 1.10 | - | Vrms |

Table 16. 92HD73C 5V, 4.75V, and 3.3V Analog Performance Characteristics

| Parameter | Conditions | AVdd | Min | Typ | Max | Unit |
|---|--|---------------------|----------------|----------------|-----|-------------------|
| All Analog Inputs with boost | 10dB Boost | 5V 4.75V 3.3V | 0.31 | - | - | Vrms |
| All Analog Inputs with boost | 20dB Boost | 5V 4.75V 3.3V | 0.10 | - | - | Vrms |
| All Analog Inputs with boost | 30dB Boost | 5V 4.75V 3.3V | 0.03 | - | - | Vrms |
| Input Impedance | | All | - | 50 | - | K Ω |
| Input Capacitance | | All | - | 15 | - | pF |
| Analog Mixer | | | | | | |
| SNR ² - All Line-Inputs or DACs to A, B, and D headphone capable outputs | Analog Mixer Enabled, 10K Ω load. DAC playing silence, line inputs driven by ATE. Gain set to 0dB | 5V 4.75V 3.3V | 85 85 85 | 90 90 90 | | dB |
| THD+N ³ - All Line-Inputs or DACs to A, B, and D headphone capable outputs | Analog Mixer Enabled, 0dB FS Signal, 10K Ω load | 5V 4.75V 3.3V | 70 70 70 | 75 75 75 | | dBr |
| SNR ² - All Line-Inputs or DACs to A, B, and D headphone capable outputs | Analog Mixer Enabled, 32 Ω load. DAC playing silence, Line inputs driven by ATE. | 5V 4.75V 3.3V | 85 85 85 | 90 90 90 | | dB |
| THD+N ³ - All Line-Inputs or DACs to A, B, and D headphone capable outputs | Analog Mixer Enabled, 0dB FS Signal, 32 Ω load | 5V 4.75V 3.3V | 60 60 60 | 70 70 70 | | dBr |
| SNR ² - DAC to All Line-Out Ports (C, E, F, G, and H) | Analog Mixer Enabled, DACs playing silence, line inputs driven by ATE. Gain set to 0dB | 5V 4.75V 3.3V | 85 85 85 | 90 90 90 | | dB |
| THD+N ³ - DAC to All Line-Out Ports (C, E, F, G, and H) | Analog Mixer Enabled, 0dB FS Signal, , 10K Ω load | 5V 4.75V 3.3V | 70 70 70 | 75 75 75 | | dBr |
| Attenuation, Gain Step Size ANALOG | | All | - | 1.5 | - | dB |
| Gain Drift ⁷ | | All | - | 100 | - | ppm/ $^{\circ}$ C |
| Analog to Digital Converter | | | | | | |
| Resolution | | All | | 24 | | Bits |
| Dynamic Range ¹ , All Analog Inputs to A/D | High Pass Filer Enabled, -60dB FS, No boost | 5V 4.75V 3.3V | 86 86 83 | 90 90 85 | | dB |
| SNR ² - All Analog Inputs to A/D | High Pass Filter enabled | 5V 4.75V 3.3V | 86 86 83 | 90 90 85 | | dB |
| THD+N ³ All Analog Inputs to A/D | High Pass Filter enabled, -1dB FS signal level | 5V 4.75V 3.3V | 75 75 65 | 85 85 75 | | dBr |

Table 16. 92HD73C 5V, 4.75V, and 3.3V Analog Performance Characteristics

| Parameter | Conditions | AVdd | Min | Typ | Max | Unit |
|---|---|---------------------|----------------|----------------|--------|--------|
| THD+N ³ All Analog Inputs to A/D | High Pass Filter enabled, -3dB FS signal level | 5V 4.75V 3.3V | 75 75 65 | 85 85 75 | | dBr |
| Analog Frequency Response ⁸ | | All | 10 | - | 30,000 | Hz |
| A/D Digital Filter Pass Band ⁴ | | All | 20 | - | 21,000 | Hz |
| A/D Digital Filter Transition Band | | All | 21,000 | - | 31,000 | Hz |
| A/D Digital Filter Stop Band | | All | 31,000 | - | - | Hz |
| A/D Digital Filter Stop Band Rejection ⁵ | | All | -100 | -90 | - | dB |
| Group Delay | 48 KHz sample rate | All | - | - | 1 | ms |
| Any unselected analog Input to ADC Crosstalk | 10KHz Signal Frequency | All | -65 | -80 | - | dB |
| Any unselected analog Input to ADC Crosstalk | 1KHz Signal Frequency | All | -65 | -85 | - | dB |
| ADC L/R crosstalk | Any selected input to ADC 20-15Khz | All | -65 | | | dB |
| DAC to ADC crosstalk | DAC output 0dBFS. All outputs loaded. Input to ADC open. 20-15Khz | All | -55 | | | dB |
| Spurious Tone Rejection ⁹ | | All | - | -100 | - | dB |
| Attenuation, Gain Step Size (analog) | | All | - | 1.5 | - | dB |
| Gain Drift | | All | - | 100 | - | ppm/°C |
| Interchannel Gain Mismatch ADC | | All | - | - | 0.5 | dB |
| Power Supply | | | | | | |
| Power Supply Rejection Ratio | 10kHz | All | - | -60 | - | dB |
| Power Supply Rejection Ratio | 1kHz | All | - | -70 | - | dB |
| D0 (7.1 Playback)¹⁰ | Single 7.1 stream. No ADC or SPDIF | | | | | |
| Didd | 3.3V | | | 68 | | mA |
| Aidd | 5.0V, 4.75V, & 3.3V | | | 50 | | mA |
| D0 (Stereo Playback)¹⁰ | Single 2 channel stream. No ADC or SPDIF | | | | | |
| Didd | 3.3V | | | 38 | | mA |
| Aidd | 5.0V, 4.75V, & 3.3V | | | 37 | | mA |
| D0 (idle)¹⁰ | All converters enabled but no streams playing | | | | | |
| Didd | 3.3V | | | 55 | | mA |
| Aidd | 5.0V, 4.75V, & 3.3V | | | 72 | | mA |
| D1¹⁰ | Analog mixer active, all converters and ports off | | | | | |
| D1 Didd | 3.3V | | | 14 | | mA |

Table 16. 92HD73C 5V, 4.75V, and 3.3V Analog Performance Characteristics

| Parameter | Conditions | AVdd | Min | Typ | Max | Unit |
|--|-------------------------------------|------|-----|-------------|-----|------|
| D1 Aidd | 5.0V, 4.75V, & 3.3V | | | 35 | | mA |
| D2¹⁰ | All converters, ports and mixer off | | | | | |
| D2 Didd | 3.3V | | | 14 | | mA |
| D2 Aidd | 5.0V, 4.75V, & 3.3V | | | 28 | | mA |
| D3¹⁰ | Anti-pop enabled | | | | | |
| D3 Didd | 3.3V | | | 3 | | mA |
| D3 Aidd | 5.0V, 4.75V, & 3.3V | | | 14 | | mA |
| Differential Power¹⁰ | Per converter power consumption | | | | | |
| One Stereo ADC Didd | 3.3V | | | 11 | | mA |
| One Stereo ADC Aidd | 5.0V, 4.75V, & 3.3V | | | 3 | | mA |
| One Stereo DAC Didd | 3.3V | | | 10 | | mA |
| One Stereo DAC Aidd | 5.0V, 4.75V, & 3.3V | | | 4 | | mA |
| Voltage Reference Outputs | | | | | | |
| VREFOut ¹⁰ | | All | - | 0.5 X AVdd | - | V |
| VREFILT (VAG) | | All | | 0.45 X AVdd | | V |
| Phased Locked Loop | | | | | | |
| PLL lock time | | All | | 96 | 200 | usec |
| PLL (or HD Audio Bit CLK) 24MHz clock jitter | | All | | 150 | 500 | psec |
| ESD / Latchup | | | | | | |
| Latch-up | As described in JESD78A Class II | All | | 70 | | degC |
| ESD - Human Body Model | As described in JESD22-A114-B | All | 2K | 3K | | V |
| Charged Device Model | As described in JESD22-C101 | All | 500 | 1K | | V |

Table 16. 92HD73C 5V, 4.75V, and 3.3V Analog Performance Characteristics

1. Dynamic Range is the ratio of the full scale signal to the noise output with a -60dBFS signal as defined in AES17 as SNR in the presence of signal and outlined in AES6id, measured "A weighted" over 20 Hz to 20 kHz bandwidth
2. Ratio of Full Scale signal to idle channel noise output is measured "A weighted" over a 20 Hz to a 20 kHz bandwidth. (AES17-1991 Idle Channel Noise or EIAJ CP-307 Signal-to-noise Ratio).
3. THD+N ratio as defined in AES17 and outlined in AES6id, non-weighted, over 20 Hz to 20 kHz bandwidth. Results at the jack are dependent on external components and will likely be 1 - 2dB worse.
4. Peak-to-Peak Ripple over Passband meets ± 0.125 dB limits, 48 kHz or 44.1 kHz Sample Frequency. 1dB limit.
5. Stop Band rejection determines filter requirements. Out-of-Band rejection determines audible noise.
6. The integrated Out-of-Band noise generated by the DAC process, during normal PCM audio playback, over a bandwidth 28.8 to 100 kHz, with respect to a 1 Vrms DAC output.
7. Gain drift is the change in analog volume control gain for each step across the supported 0 °C TO 70 °C temperature range referenced to the 25 °C gain value and specified in ppm per °C
8. ± 1 dB limits for Line Output & 0 dB gain, at -20dBV
9. Spurious tone rejection is tested with ADC dither enabled and compared to ADC performance without dither.
10. Can be set to 0.5 or 0.8 AVdd.

3. PORT CONFIGURATIONS

Entertainment PC

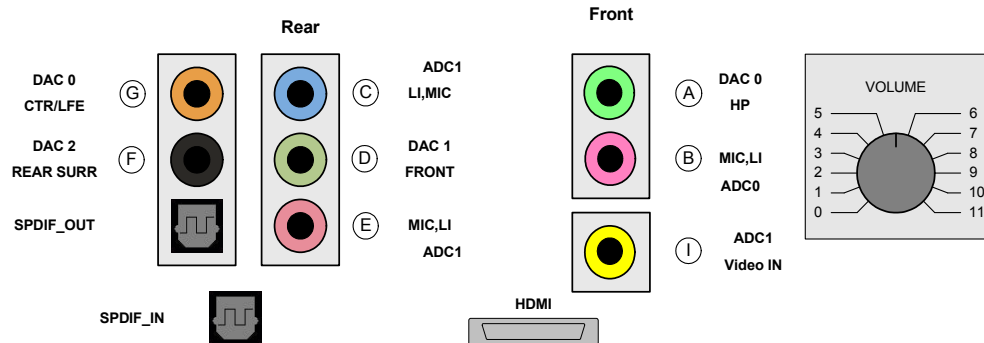

Consumer Desktop

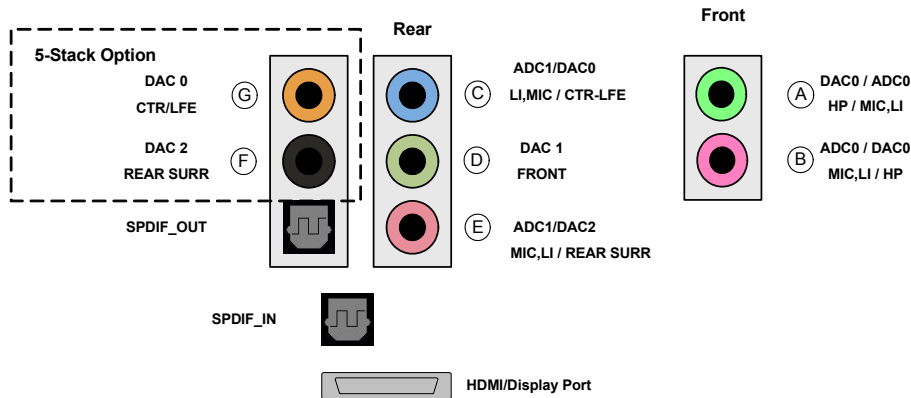

Mobile

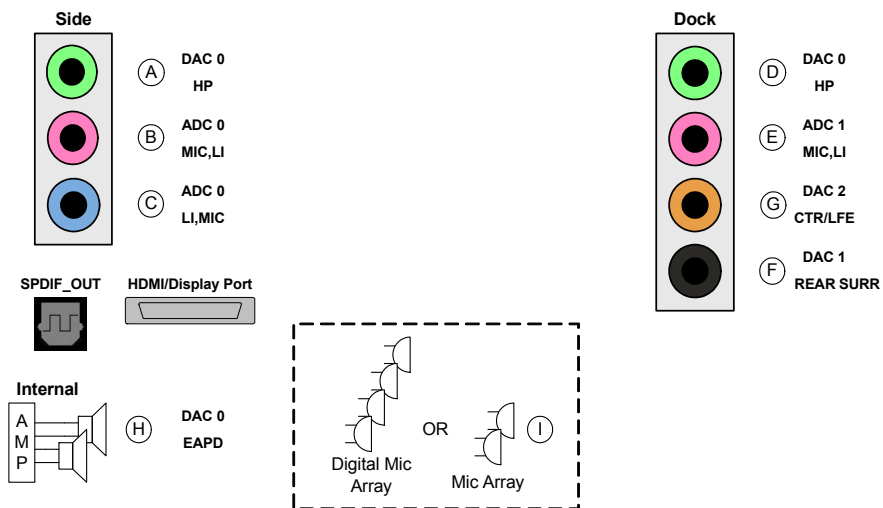

3 stereo DACs / 2 stereo ADCs, 8 ports UJ. 9 stereo ports total. Two SPDIF outputs. 3 HEADPHONE PORTS
 DAC output can be mixed with inputs for record or playback.

Figure 10. Port Configuration

4. FUNCTIONAL BLOCK DIAGRAMS

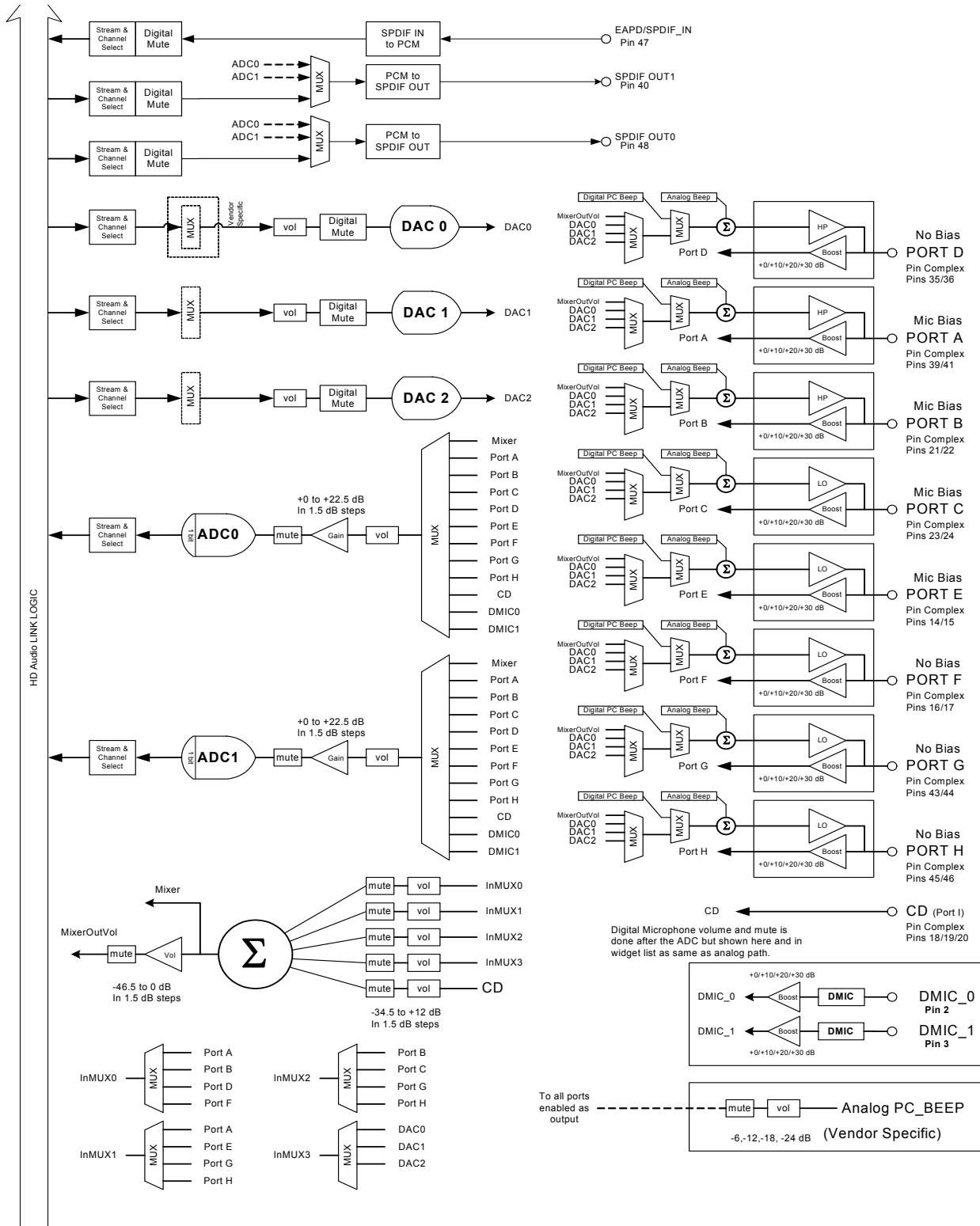

Figure 11. Functional Block Diagram

5. WIDGET INFORMATION AND SUPPORTED COMMAND VERBS

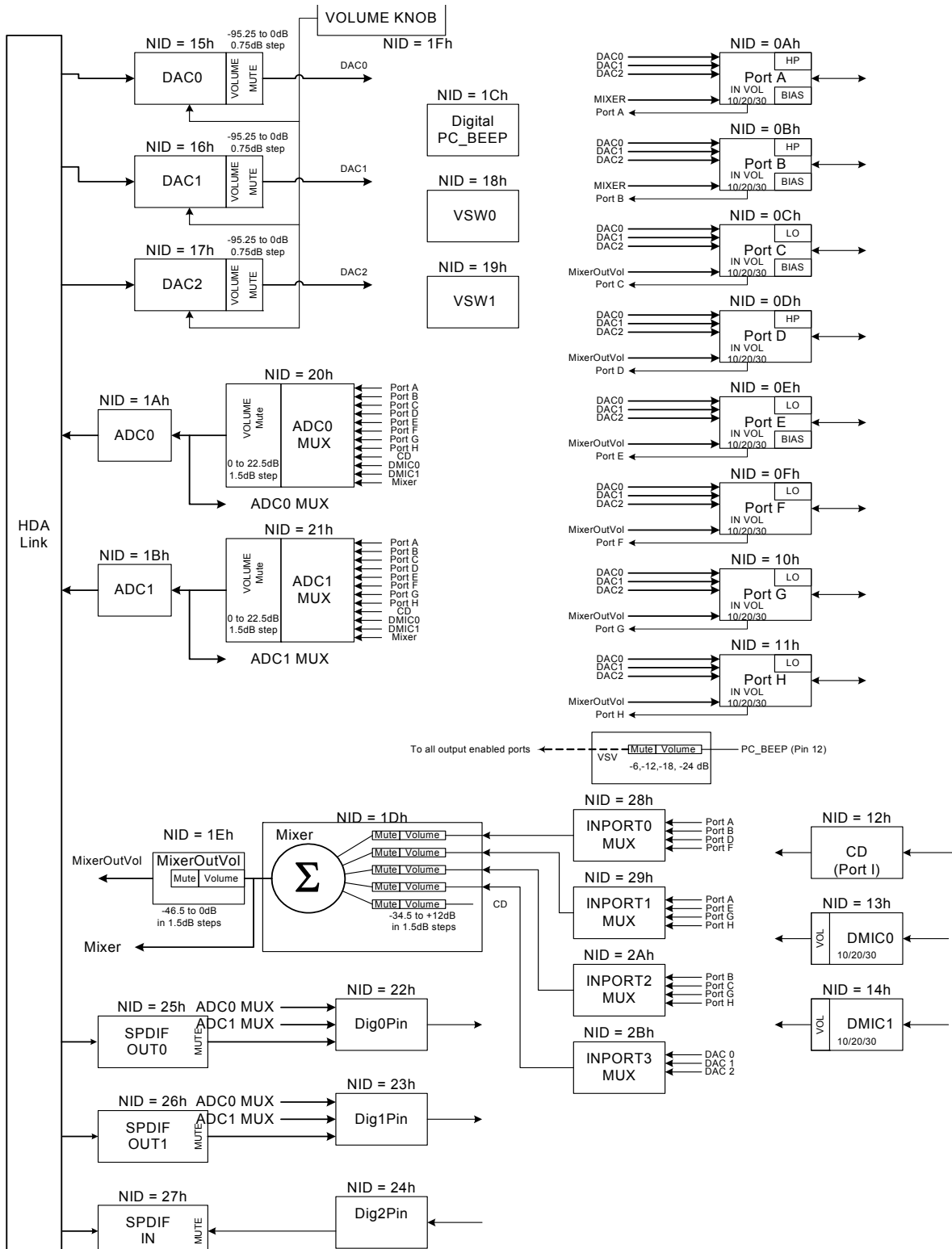

Figure 12. Widget Diagram

5.1. Widget List

| ID | Widget Name | Description |
|-----|-------------|--|
| 00h | Root | Root Node |
| 01h | AFG | Audio Function Group |
| 0Ah | Port A | Port A Pin Widget (Configurable as HP, Line Out, Line In, Mic) |
| 0Bh | Port B | Port B Pin Widget (Configurable as HP, Line Out, Line In, Mic) |
| 0Ch | Port C | Port C Pin Widget (Configurable as Line In, Mic, Line Out) |
| 0Dh | Port D | Port D Pin Widget (Configurable as HP, Line Out, Line In, Mic) |
| 0Eh | Port E | Port E Pin Widget (Configurable as Line In, Mic, Line Out) |
| 0Fh | Port F | Port F Pin Widget (Configurable as Line In, Mic, Line Out) |
| 10h | Port G | Port G Pin Widget (Configurable as Line In, Mic, Line Out) |
| 11h | Port H | Port H Pin Widget (Configurable as Line In, Mic, Line Out) |
| 12h | CD (Port I) | CD Pin Widget (Configurable as Line In) |
| 13h | DigMic0 | Digital Microphone 0 Pin Widget |
| 14h | DigMic1 | Digital Microphone 1 Pin Widget |
| 15h | DAC0 | Stereo Output Converter to DAC |
| 16h | DAC1 | Stereo Output Converter to DAC |
| 17h | DAC2 | Stereo Output Converter to DAC |
| 18h | Rsvd | Reserved |
| 19h | rsvd | Reserved |
| 1Ah | ADC0 | Stereo Input Converter to ADC |
| 1Bh | ADC1 | Stereo Input Converter to ADC |
| 1Ch | PCBeep | Digital PC Beep |
| 1Dh | Mixer | Mixer (Input Ports, DACs, Analog PC_Beep) |
| 1Eh | MixerOutVol | Mixer Out Volume |
| 1Fh | VolumeKnob | External Volume Control |
| 20h | ADC0Mux | ADC0 Mux with volume and mute |
| 21h | ADC1Mux | ADC1 Mux with volume and mute |
| 22h | Dig0Pin | Digital Output Pin (pin48) |
| 23h | Dig1Pin | Secondary Digital Output Pin (pin 40) |
| 24h | Dig2Pin | EAPD and Digital Input Pin (Pin 47) |
| 25h | SPDIFOut0 | Stereo Output for SPDIF_Out |
| 26h | SPDIFOut1 | Second Stereo Output for SPDIF_Out |
| 27h | SPDIFIn | Stereo converter widget for SPDIF_In |

Table 17. High Definition Audio Widget

| ID | Widget Name | Description |
|-----|-------------|---------------------------------|
| 28h | InPort0Mux | Input port pre-select for mixer |
| 29h | InPort1Mux | input port pre-select for mixer |
| 2Ah | InPort2Mux | input port pre-select for mixer |
| 2Bh | InPort3Mux | input port pre-select for mixer |

Table 17. High Definition Audio Widget

5.2. Pin Configuration Default Register Settings

The configuration default registers are 32-bit registers required for each pin widget. These registers are normally used by the CODEC driver to determine the configuration of jacks and devices attached to the CODEC. When the CODEC is powered on, these registers are loaded with the default values provided by IDT for typical system usage, and are loaded in a way that is compatible with the Microsoft Universal Audio Architecture (UAA) driver. The values can be overridden by IDT customers according to their system configuration. Table 18 shows the Pin Widget Configuration Default settings.

Will be provided in the next datasheet release.

6. WIDGET INFORMATION

| Bits [39:32] | Bits [31:28] | BITS [27:20] | BITS[19:16] | BITS [15:0] |
|--------------|---------------|--------------|-----------------|-----------------------|
| Reserved | CODEC Address | NID | Verb ID (4-bit) | Payload Data (16-bit) |

Table 18. Command Format for Verb with 4-bit Identifier

| Bits [39:32] | Bits [31:28] | BITS [27:20] | BITS[19:8] | BITS [7:0] |
|--------------|---------------|--------------|------------------|----------------------|
| Reserved | CODEC Address | NID | Verb ID (12-bit) | Payload Data (8-bit) |

Table 19. Command Format for Verb with 12-bit Identifier

There are two types of responses: Solicited and Unsolicited. Solicited responses are provided as a direct response to an issued command and will be provided in the frame immediately following the command. Unsolicited responses are provided by the CODEC independent of any command. Unsolicited responses are the result of CODEC events such as a jack insertion detection. The formats for Solicited Responses and Unsolicited Responses are shown in the tables below. The “Tag” field in bits [31:28] of the Unsolicited Response identify the event.

| Bit [35] | Bit [34] | BITS [33:32] | BITS[31:0] |
|-------------------|-----------|--------------|------------|
| Valid (Valid = 1) | UnSol = 0 | Reserved | Response |

Table 20. Solicited Response Format

| Bit [35] | Bit [34] | BITS [33:32] | BITS[31:28] | BITS [27:0] |
|-------------------|-----------|--------------|-------------|-------------|
| Valid (Valid = 1) | UnSol = 1 | Reserved | Tag | Response |

Table 21. Unsolicited Response Format

6.1. Root Node (NID = 00)

)

6.1.1. Root VendorID

| | Verb ID | Payload | Response |
|-----|---------|---------|---------------------|
| Get | F00 | 00 | See bitfield table. |

6.1.1.1. *Root VendorID*

| Bit | Bitfield Name | RW | Reset | Description |
|----------|---------------|----|-------|-----------------|
| [31..16] | Vendor | R | 111D | Vendor ID. |
| [15..8] | DeviceFix | R | 76 | Device ID 7675h |
| [7..0] | DeviceProg | R | 75 | Device ID 7675h |

6.1.2. *Root RevID*

| | Verb ID | Payload | Response |
|-----|---------|---------|---------------------|
| Get | F00 | 02 | See bitfield table. |

6.1.2.1. *Root RevID*

| Bit | Bitfield Name | RW | Reset | Description |
|----------|---------------|----|-------|--|
| [31..24] | Rsvd | R | 00 | Reserved. |
| [23..20] | Major | R | 1 | Compliant HDAudio spec major revision. |
| [19..16] | Minor | R | 0 | Compliant HDAudio spec minor revision |
| [15..12] | RevisionFix | R | 0 | Vendors rev number for this device. |
| [11..8] | RevisionProg | R | 1 | Vendors rev number for this device. |
| [7..4] | SteppingFix | R | 0 | Vendor RevID. |
| [3..0] | SteppingProg | R | 1 | Vendor RevID. |

6.1.2.2. *Root NodeInfo*

| Bit | Bitfield Name | RW | Reset | Description |
|----------|---------------|----|-------|--|
| [31..24] | Rsvd2 | R | 00 | Reserved. |
| [23..16] | StartNID | R | 01 | Starting node number (NID) of first function group |
| [15..8] | Rsvd1 | R | 00 | Reserved. |
| [7..0] | TotalNodes | R | 01 | Total number of nodes |

6.2. AFG Node (NID = 01)

)

6.2.1. AFG Reset

| | Verb ID | Payload | Response |
|-----|---------|---------|---------------------|
| Get | | | See bitfield table. |

6.2.1.1. AFG Reset

| Bit | Bitfield Name | RW | Reset | Description |
|---------|---------------|----|--------|-----------------|
| [31..8] | Rsvd1 | R | 000000 | Reserved. |
| [7..0] | Execute | W | 00 | Function Reset. |

6.2.2. AFG NodeInfo

| | Verb ID | Payload | Response |
|-----|---------|---------|---------------------|
| Get | F00 | 04 | See bitfield table. |

6.2.2.1. AFG NodeInfo

| Bit | Bitfield Name | RW | Reset | Description |
|----------|---------------|----|-------|--|
| [31..24] | Rsvd2 | R | 00 | Reserved. |
| [23..16] | StartNID | R | 0A | Starting node number for function group subordinate nodes. |
| [15..8] | Rsvd1 | R | 00 | Reserved. |
| [7..0] | TotalNodes | R | 22 | Total number of nodes. |

6.2.3. AFG FGType

| | Verb ID | Payload | Response |
|-----|---------|---------|---------------------|
| Get | F00 | 05 | See bitfield table. |

6.2.3.1. *AFG FGType*

| Bit | Bitfield Name | RW | Reset | Description |
|---------|---------------|----|--------|---|
| [31..9] | Rsvd | R | 000000 | Reserved. |
| [8] | UnSol | R | 1 | Unsolicited response supported: 1 = yes 0 = no. |
| [7..0] | NodeType | R | 1 | Function group type: 00h = Reserved; 01h = Audio Function Group; 02h = Vendor Defined Modem Function Group; 03h-7Fh = Reserved; 80h-FFh = Vendor Defined Function Group |

6.2.4. *AFG AFGCap*

| | Verb ID | Payload | Response |
|-----|---------|---------|---------------------|
| Get | F00 | 08 | See bitfield table. |

6.2.4.1. *AFG AFGCap*

| Bit | Bitfield Name | RW | Reset | Description |
|----------|---------------|----|-------|--|
| [31..17] | Rsvd3 | R | 00 | Reserved. |
| [16] | BeepGen | R | 1 | Beep generator present: 1 = yes 0 = no. |
| [15..12] | Rsvd2 | R | 0 | Reserved. |
| [11..8] | InputDelay | R | D | Typical latency in frames. Number of samples between when the sample is received as an analog signal at the pin and when the digital representation is transmitted on the HD Audio link. |
| [7..4] | Rsvd1 | R | 0 | Reserved. |
| [3..0] | OutputDelay | R | D | Typical latency in frames. Number of samples between when the signal is received from the HD Audio link and when it appears as an analog signal at the pin. |

6.2.5. AFG PCMCap

| | Verb ID | Payload | Response |
|-----|---------|---------|---------------------|
| Get | F00 | 0A | See bitfield table. |

6.2.5.1. AFG PCMCap

| Bit | Bitfield Name | RW | Reset | Description |
|----------|---------------|----|-------|---|
| [31..21] | Rsvd2 | R | 000 | Reserved. |
| [20] | B32 | R | 0 | 32 bit audio format support: 1 = yes 0 = no. |
| [19] | B24 | R | 1 | 24 bit audio format support: 1 = yes 0 = no. |
| [18] | B20 | R | 1 | 20 bit audio format support: 1 = yes 0 = no. |
| [17] | B16 | R | 1 | 16 bit audio format support: 1 = yes 0 = no. |
| [16] | B8 | R | 0 | 8 bit audio format support: 1 = yes 0 = no. |
| [15..12] | Rsvd1 | R | 0 | Reserved. |
| [11] | R12 | R | 0 | 384kHz rate support: 1 = yes 0 = no. |
| [10] | R11 | R | 1 | 192kHz rate support: 1 = yes 0 = no. |
| [9] | R10 | R | 1 | 176.4kHz rate support: 1 = yes 0 = no. |
| [8] | R9 | R | 1 | 96kHz rate support: 1 = yes 0 = no. |
| [7] | R8 | R | 1 | 88.2kHz rate support: 1 = yes 0 = no. |
| [6] | R7 | R | 1 | 48kHz rate support: 1 = yes 0 = no. |
| [5] | R6 | R | 1 | 44.1kHz rate support: 1 = yes 0 = no. |
| [4] | R5 | R | 0 | 32kHz rate support: 1 = yes 0 = no. |
| [3] | R4 | R | 0 | 22.05kHz rate support: 1 = yes 0 = no. |
| [2] | R3 | R | 0 | 16kHz rate support: 1 = yes 0 = no. |

6.2.5.1. *AFG PCMCap*

| Bit | Bitfield Name | RW | Reset | Description |
|-----|---------------|----|-------|---|
| [1] | R2 | R | 0 | 11.025kHz rate support: 1 = yes 0 = no. |
| [0] | R1 | R | 0 | 8kHz rate support: 1 = yes 0 = no. |

6.2.6. *AFG StreamCap*

| | Verb ID | Payload | Response |
|-----|---------|---------|---------------------|
| Get | F00 | 0B | See bitfield table. |

6.2.6.1. *AFG StreamCap*

| Bit | Bitfield Name | RW | Reset | Description |
|---------|---------------|----|----------|--|
| [31..3] | Rsvd | R | 00000000 | Reserved. |
| [2] | AC3 | R | 0 | AC-3 formatted data support: 1 = yes 0 = no. |
| [1] | Float32 | R | 0 | Float32 formatted data support: 1 = yes 0 = no. |
| [0] | PCM | R | 1 | PCM-formatted data support: 1 = yes 0 = no. |

6.2.7. *AFG InAmpCap*

| | Verb ID | Payload | Response |
|-----|---------|---------|---------------------|
| Get | F00 | 0D | See bitfield table. |

6.2.7.1. *AFG InAmpCap*

| Bit | Bitfield Name | RW | Reset | Description |
|----------|---------------|----|-------|---|
| [31] | Mute | R | 0 | Mute support: 1 = yes 0 = no. |
| [30..23] | Rsvd3 | R | 00 | Reserved. |
| [22..16] | StepSize | R | 27 | Size of each step in the gain range: 0 to 127 = .25dB to 32dB in .25dB steps. |

6.2.7.1. *AFG InAmpCap*

| Bit | Bitfield Name | RW | Reset | Description |
|---------|---------------|----|-------|--|
| [15] | Rsvd2 | R | 0 | Reserved. |
| [14..8] | NumSteps | R | 03 | Number of gains steps (number of possible settings - 1). |
| [7] | Rsvd1 | R | 0 | Reserved. |
| [6..0] | Offset | R | 00 | Indicates which step is 0dB |

6.2.8. *AFG PwrStateCap*

| | Verb ID | Payload | Response |
|-----|---------|---------|---------------------|
| Get | F00 | 0F | See bitfield table. |

6.2.8.1. *AFG PwrStateCap*

| Bit | Bitfield Name | RW | Reset | Description |
|---------|---------------|----|---------|---|
| [31..4] | Rsvd | R | 0000000 | Reserved. |
| [3] | D3Sup | R | 1 | D3 power state support: 1 = yes 0 = no. |
| [2] | D2Sup | R | 1 | D2 power state support: 1 = yes 0 = no. |
| [1] | D1Sup | R | 1 | D1 power state support: 1 = yes 0 = no. |
| [0] | D0Sup | R | 1 | D0 power state support: 1 = yes 0 = no. |

6.2.9. *AFG GPIOCnt*

| | Verb ID | Payload | Response |
|-----|---------|---------|---------------------|
| Get | F00 | 11 | See bitfield table. |

6.2.9.1. *AFG GPIOCnt*

| Bit | Bitfield Name | RW | Reset | Description |
|----------|---------------|----|-------|--|
| [31] | GPIWake | R | 1 | Wake capability. Assuming the Wake Enable Mask controls are enabled GPIOs configured as inputs can cause a wake (generate a Status Change event on the link) when there is a change in level on the pin. |
| [30] | GPIUnsol | R | 1 | GPIO unsolicited response support: 1 = yes 0 = no. |
| [29.:24] | Rsvd | R | 00 | Reserved. |
| [23.:16] | NumGPIs | R | 00 | Number of GPI pins supported by function group. |
| [15.:8] | NumGPOs | R | 00 | Number of GPO pins supported by function group. |
| [7.:0] | NumGPIOs | R | 08 | Number of GPIO pins supported by function group. |

6.2.10. *AFG OutAmpCap*

| | Verb ID | Payload | Response |
|-----|---------|---------|---------------------|
| Get | F00 | 12 | See bitfield table. |

6.2.10.1. *AFG OutAmpCap*

| Bit | Bitfield Name | RW | Reset | Description |
|----------|---------------|----|-------|---|
| [31] | Mute | R | 1 | Mute support: 1 = yes 0 = no. |
| [30.:23] | Rsvd3 | R | 00 | Reserved. |
| [22.:16] | StepSize | R | 02 | Size of each step in the gain range: 0 to 127 = .25dB to 32dB in .25dB steps. |
| [15] | Rsvd2 | R | 0 | Reserved. |

6.2.10.1. AFG OutAmpCap

| Bit | Bitfield Name | RW | Reset | Description |
|---------|---------------|----|-------|--|
| [14.:8] | NumSteps | R | 7F | Number of gains steps (number of possible settings - 1). |
| [7] | Rsvd1 | R | 0 | Reserved. |
| [6.:0] | Offset | R | 7F | Indicates which step is 0dB |

6.2.11. AFG PwrState

| | Verb ID | Payload | Response |
|-----|---------|---------|---------------------|
| Get | F05 | 00 | See bitfield table. |

6.2.11.1. AFG PwrState

| Bit | Bitfield Name | RW | Reset | Description |
|---------|---------------|----|---------|--|
| [31.:6] | Rsvd2 | R | 0000000 | Reserved. |
| [5.:4] | Act | R | 3 | Actual power state of this widget. |
| [3.:2] | Rsvd1 | R | 0 | Reserved. |
| [1.:0] | Set | RW | 3 | Current power state setting for this widget. |

6.2.12. AFG UnsolResp

| | Verb ID | Payload | Response |
|-----|---------|---------|---------------------|
| Get | F08 | 00 | See bitfield table. |

6.2.12.1. AFG UnsolResp

| Bit | Bitfield Name | RW | Reset | Description |
|---------|---------------|----|--------|---|
| [31.:8] | Rsvd2 | R | 000000 | Reserved. |
| [7] | En | RW | 0 | Unsolicited response enable: 1 = enabled 0 = disabled. |

6.2.12.1. *AFG UnsolResp*

| Bit | Bitfield Name | RW | Reset | Description |
|--------|---------------|----|-------|--|
| [6] | Rsvd1 | R | 0 | Reserved. |
| [5.:0] | Tag | RW | 00 | Software programmable field returned in top six bits (31:26) of every Unsolicited Response generated by this node. |

6.2.13. *AFG GPIO*

| | Verb ID | Payload | Response |
|-----|---------|---------|---------------------|
| Get | F15 | 00 | See bitfield table. |

6.2.13.1. *AFG GPIO*

| Bit | Bitfield Name | RW | Reset | Description |
|---------|---------------|----|--------|---|
| [31.:8] | Rsvd | R | 000000 | Reserved. |
| [7] | Data7 | RW | 0 | Data for GPIO7. If this GPIO bit is configured as Sticky (edge-sensitive) input it can be cleared by writing "0". For details of read back value refer to HD Audio spec. section 7.3.3.22 |
| [6] | Data6 | RW | 0 | Data for GPIO6. If this GPIO bit is configured as Sticky (edge-sensitive) input it can be cleared by writing "0". For details of read back value refer to HD Audio spec. section 7.3.3.22 |
| [5] | Data5 | RW | 0 | Data for GPIO5. If this GPIO bit is configured as Sticky (edge-sensitive) input it can be cleared by writing "0". For details of read back value refer to HD Audio spec. section 7.3.3.22 |
| [4] | Data4 | RW | 0 | Data for GPIO4. If this GPIO bit is configured as Sticky (edge-sensitive) input it can be cleared by writing "0". For details of read back value refer to HD Audio spec. section 7.3.3.22 |

6.2.13.1. AFG GPIO

| Bit | Bitfield Name | RW | Reset | Description |
|-----|---------------|----|-------|---|
| [3] | Data3 | RW | 0 | Data for GPIO3. If this GPIO bit is configured as Sticky (edge-sensitive) input it can be cleared by writing "0". For details of read back value refer to HD Audio spec. section 7.3.3.22 |
| [2] | Data2 | RW | 0 | Data for GPIO2. If this GPIO bit is configured as Sticky (edge-sensitive) input it can be cleared by writing "0". For details of read back value refer to HD Audio spec. section 7.3.3.22 |
| [1] | Data1 | RW | 0 | Data for GPIO1. If this GPIO bit is configured as Sticky (edge-sensitive) input it can be cleared by writing "0". For details of read back value refer to HD Audio spec. section 7.3.3.22 |
| [0] | Data0 | RW | 0 | Data for GPIO0. If this GPIO bit is configured as Sticky (edge-sensitive) input it can be cleared by writing "0". For details of read back value refer to HD Audio spec. section 7.3.3.22 |

6.2.14. AFG GPIOEn

| | Verb ID | Payload | Response |
|-----|---------|---------|---------------------|
| Get | F16 | 00 | See bitfield table. |

6.2.14.1. AFG GPIOEn

| Bit | Bitfield Name | RW | Reset | Description |
|---------|---------------|----|--------|---|
| [31..8] | Rsvd | R | 000000 | Reserved. |
| [7] | Mask7 | RW | 0 | Enable for GPIO7: 0 = pin is disabled (Hi-Z state); 1 = pin is enabled; behavior determined by GPIO Direction control |
| [6] | Mask6 | RW | 0 | Enable for GPIO6: 0 = pin is disabled (Hi-Z state); 1 = pin is enabled; behavior determined by GPIO Direction control |

6.2.14.1. AFG GPIOEn

| Bit | Bitfield Name | RW | Reset | Description |
|-----|---------------|----|-------|---|
| [5] | Mask5 | RW | 0 | Enable for GPIO5: 0 = pin is disabled (Hi-Z state); 1 = pin is enabled; behavior determined by GPIO Direction control |
| [4] | Mask4 | RW | 0 | Enable for GPIO4: 0 = pin is disabled (Hi-Z state); 1 = pin is enabled; behavior determined by GPIO Direction control |
| [3] | Mask3 | RW | 0 | Enable for GPIO3: 0 = pin is disabled (Hi-Z state); 1 = pin is enabled; behavior determined by GPIO Direction control |
| [2] | Mask2 | RW | 0 | Enable for GPIO2: 0 = pin is disabled (Hi-Z state); 1 = pin is enabled; behavior determined by GPIO Direction control |
| [1] | Mask1 | RW | 0 | Enable for GPIO1: 0 = pin is disabled (Hi-Z state); 1 = pin is enabled; behavior determined by GPIO Direction control |
| [0] | Mask0 | RW | 0 | Enable for GPIO0: 0 = pin is disabled (Hi-Z state); 1 = pin is enabled; behavior determined by GPIO Direction control |

6.2.15. AFG GPIODir

| | Verb ID | Payload | Response |
|-----|---------|---------|---------------------|
| Get | F17 | 00 | See bitfield table. |

6.2.15.1. AFG GPIODir

| Bit | Bitfield Name | RW | Reset | Description |
|---------|---------------|----|--------|--|
| [31..8] | Rsvd | R | 000000 | Reserved. |
| [7] | Control7 | RW | 0 | Direction control for GPIO7: 0 = GPIO is configured as input; 1 = GPIO is configured as output |
| [6] | Control6 | RW | 0 | Direction control for GPIO6: 0 = GPIO is configured as input; 1 = GPIO is configured as output |

6.2.15.1. AFG GPIODir

| Bit | Bitfield Name | RW | Reset | Description |
|-----|---------------|----|-------|--|
| [5] | Control5 | RW | 0 | Direction control for GPIO5: 0 = GPIO is configured as input; 1 = GPIO is configured as output |
| [4] | Control4 | RW | 0 | Direction control for GPIO4: 0 = GPIO is configured as input; 1 = GPIO is configured as output |
| [3] | Control3 | RW | 0 | Direction control for GPIO3: 0 = GPIO is configured as input; 1 = GPIO is configured as output |
| [2] | Control2 | RW | 0 | Direction control for GPIO2: 0 = GPIO is configured as input; 1 = GPIO is configured as output |
| [1] | Control1 | RW | 0 | Direction control for GPIO1: 0 = GPIO is configured as input; 1 = GPIO is configured as output |
| [0] | Control0 | RW | 0 | Direction control for GPIO0: 0 = GPIO is configured as input; 1 = GPIO is configured as output |

6.2.16. AFG GPIOWakeEn

| | Verb ID | Payload | Response |
|-----|---------|---------|---------------------|
| Get | F18 | 00 | See bitfield table. |

6.2.16.1. AFG GPIOWakeEn

| Bit | Bitfield Name | RW | Reset | Description |
|---------|---------------|----|--------|---|
| [31..8] | Rsvd | R | 000000 | Reserved. |
| [7] | W7 | RW | 0 | Wake enable for GPIO7: 0 = wake-up event is disabled; 1 = When HD Audio link is powered down (RST# is asserted) a wake-up event will trigger a Status Change Request event on the link. |

6.2.16.1. AFG GPIOWakeEn

| Bit | Bitfield Name | RW | Reset | Description |
|-----|---------------|----|-------|---|
| [6] | W6 | RW | 0 | Wake enable for GPIO6: 0 = wake-up event is disabled; 1 = When HD Audio link is powered down (RST# is asserted) a wake-up event will trigger a Status Change Request event on the link. |
| [5] | W5 | RW | 0 | Wake enable for GPIO5: 0 = wake-up event is disabled; 1 = When HD Audio link is powered down (RST# is asserted) a wake-up event will trigger a Status Change Request event on the link. |
| [4] | W4 | RW | 0 | Wake enable for GPIO4: 0 = wake-up event is disabled; 1 = When HD Audio link is powered down (RST# is asserted) a wake-up event will trigger a Status Change Request event on the link. |
| [3] | W3 | RW | 0 | Wake enable for GPIO3: 0 = wake-up event is disabled; 1 = When HD Audio link is powered down (RST# is asserted) a wake-up event will trigger a Status Change Request event on the link. |
| [2] | W2 | RW | 0 | Wake enable for GPIO2: 0 = wake-up event is disabled; 1 = When HD Audio link is powered down (RST# is asserted) a wake-up event will trigger a Status Change Request event on the link. |
| [1] | W1 | RW | 0 | Wake enable for GPIO1: 0 = wake-up event is disabled; 1 = When HD Audio link is powered down (RST# is asserted) a wake-up event will trigger a Status Change Request event on the link. |
| [0] | W0 | RW | 0 | Wake enable for GPIO0: 0 = wake-up event is disabled; 1 = When HD Audio link is powered down (RST# is asserted) a wake-up event will trigger a Status Change Request event on the link. |

6.2.17. AFG GPIOUnsol

| | Verb ID | Payload | Response |
|-----|---------|---------|---------------------|
| Get | F19 | 00 | See bitfield table. |

6.2.17.1. AFG GPIOUnsol

| Bit | Bitfield Name | RW | Reset | Description |
|---------|---------------|----|--------|---|
| [31..8] | Rsvd | R | 000000 | Reserved. |
| [7] | EnMask7 | RW | 0 | Unsolicited enable mask for GPIO7. If set and the Unsolicited Response control for this widget has been enabled an unsolicited response will be sent when GPIO2 is configured as input and changes state. |
| [6] | EnMask6 | RW | 0 | Unsolicited enable mask for GPIO6. If set and the Unsolicited Response control for this widget has been enabled an unsolicited response will be sent when GPIO2 is configured as input and changes state. |
| [5] | EnMask5 | RW | 0 | Unsolicited enable mask for GPIO5. If set and the Unsolicited Response control for this widget has been enabled an unsolicited response will be sent when GPIO2 is configured as input and changes state. |
| [4] | EnMask4 | RW | 0 | Unsolicited enable mask for GPIO4. If set and the Unsolicited Response control for this widget has been enabled an unsolicited response will be sent when GPIO2 is configured as input and changes state. |
| [3] | EnMask3 | RW | 0 | Unsolicited enable mask for GPIO3. If set and the Unsolicited Response control for this widget has been enabled an unsolicited response will be sent when GPIO2 is configured as input and changes state. |

6.2.17.1. AFG GPIOUnsol

| Bit | Bitfield Name | RW | Reset | Description |
|-----|---------------|----|-------|---|
| [2] | EnMask2 | RW | 0 | Unsolicited enable mask for GPIO2. If set and the Unsolicited Response control for this widget has been enabled an unsolicited response will be sent when GPIO2 is configured as input and changes state. |
| [1] | EnMask1 | RW | 0 | Unsolicited enable mask for GPIO1. If set and the Unsolicited Response control for this widget has been enabled an unsolicited response will be sent when GPIO1 is configured as input and changes state. |
| [0] | EnMask0 | RW | 0 | Unsolicited enable mask for GPIO0. If set and the Unsolicited Response control for this widget has been enabled an unsolicited response will be sent when GPIO0 is configured as input and changes state. |

6.2.18. AFG GPIOSticky

| | Verb ID | Payload | Response |
|-----|---------|---------|---------------------|
| Get | F1A | 00 | See bitfield table. |

6.2.18.1. AFG GPIOSticky

| Bit | Bitfield Name | RW | Reset | Description |
|---------|---------------|----|--------|---|
| [31..8] | Rsvd | R | 000000 | Reserved. |
| [7] | Mask7 | RW | 0 | GPIO7 input type (when configured as input): 0 = Non-Sticky (level-sensitive); 1 = Sticky (edge-sensitive). |
| [6] | Mask6 | RW | 0 | GPIO6 input type (when configured as input): 0 = Non-Sticky (level-sensitive); 1 = Sticky (edge-sensitive). |

6.2.18.1. AFG GPIOSticky

| Bit | Bitfield Name | RW | Reset | Description |
|-----|---------------|----|-------|---|
| [5] | Mask5 | RW | 0 | GPIO5 input type (when configured as input): 0 = Non-Sticky (level-sensitive); 1 = Sticky (edge-sensitive). |
| [4] | Mask4 | RW | 0 | GPIO4 input type (when configured as input): 0 = Non-Sticky (level-sensitive); 1 = Sticky (edge-sensitive). |
| [3] | Mask3 | RW | 0 | GPIO3 input type (when configured as input): 0 = Non-Sticky (level-sensitive); 1 = Sticky (edge-sensitive). |
| [2] | Mask2 | RW | 0 | GPIO2 input type (when configured as input): 0 = Non-Sticky (level-sensitive); 1 = Sticky (edge-sensitive). |
| [1] | Mask1 | RW | 0 | GPIO1 input type (when configured as input): 0 = Non-Sticky (level-sensitive); 1 = Sticky (edge-sensitive). |
| [0] | Mask0 | RW | 0 | GPIO0 input type (when configured as input): 0 = Non-Sticky (level-sensitive); 1 = Sticky (edge-sensitive). |

6.2.19. AFG SubID

| | Verb ID | Payload | Response |
|-----|---------|---------|---------------------|
| Get | F20 | 00 | See bitfield table. |

6.2.19.1. AFG SubID

| Bit | Bitfield Name | RW | Reset | Description |
|----------|---------------|----|-------|---|
| [31.:24] | Subsys3 | RW | 00 | Subsystem ID (byte 3) |
| [23.:16] | Subsys2 | RW | 00 | Subsystem ID (byte 2) |
| [15.:8] | Subsys1 | RW | 01 | Subsystem ID (byte 1) |
| [7.:0] | Assembly | RW | 00 | Assembly ID (Not applicable to codec vendors). |

6.2.20. AFG GPIOIrty

| | Verb ID | Payload | Response |
|-----|---------|---------|---------------------|
| Get | F70 | 00 | See bitfield table. |

6.2.20.1. AFG GPIOIrty

| Bit | Bitfield Name | RW | Reset | Description |
|---------|---------------|----|--------|---|
| [31..8] | Rsvd | R | 000000 | Reserved. |
| [7] | GP7 | RW | 1 | GPIO7 Polarity: If configured as output or non-sticky input: 0 = inverting; 1 = non-inverting. If configured as sticky input: 0 = falling edges will be detected; 1 = rising edges will be detected |
| [6] | GP6 | RW | 1 | GPIO6 Polarity: If configured as output or non-sticky input: 0 = inverting; 1 = non-inverting. If configured as sticky input: 0 = falling edges will be detected; 1 = rising edges will be detected |
| [5] | GP5 | RW | 1 | GPIO5 Polarity: If configured as output or non-sticky input: 0 = inverting; 1 = non-inverting. If configured as sticky input: 0 = falling edges will be detected; 1 = rising edges will be detected |
| [4] | GP4 | RW | 1 | GPIO4 Polarity: If configured as output or non-sticky input: 0 = inverting; 1 = non-inverting. If configured as sticky input: 0 = falling edges will be detected; 1 = rising edges will be detected |
| [3] | GP3 | RW | 1 | GPIO3 Polarity: If configured as output or non-sticky input: 0 = inverting; 1 = non-inverting. If configured as sticky input: 0 = falling edges will be detected; 1 = rising edges will be detected |
| [2] | GP2 | RW | 1 | GPIO2 Polarity: If configured as output or non-sticky input: 0 = inverting; 1 = non-inverting. If configured as sticky input: 0 = falling edges will be detected; 1 = rising edges will be detected |

6.2.20.1. AFG GPIOIrty

| Bit | Bitfield Name | RW | Reset | Description |
|-----|---------------|----|-------|---|
| [1] | GP1 | RW | 1 | GPIO1 Polarity: If configured as output or non-sticky input: 0 = inverting; 1 = non-inverting. If configured as sticky input: 0 = falling edges will be detected; 1 = rising edges will be detected |
| [0] | GP0 | RW | 1 | GPIO0 Polarity: If configured as output or non-sticky input: 0 = inverting; 1 = non-inverting. If configured as sticky input: 0 = falling edges will be detected; 1 = rising edges will be detected |

6.2.21. AFG GPIODrive

| | Verb ID | Payload | Response |
|-----|---------|---------|---------------------|
| Get | F71 | 00 | See bitfield table. |

6.2.21.1. AFG GPIODrive

| Bit | Bitfield Name | RW | Reset | Description |
|---------|---------------|----|--------|--|
| [31..8] | Rsvd | R | 000000 | Reserved. |
| [7] | OD7 | RW | 0 | GPIO7 Drive Mode: 0 = push-pull (drive 0 and 1); 1 = open drain (drive 0 float for 1). |
| [6] | OD6 | RW | 0 | GPIO6 Drive Mode: 0 = push-pull (drive 0 and 1); 1 = open drain (drive 0 float for 1). |
| [5] | OD5 | RW | 0 | GPIO5 Drive Mode: 0 = push-pull (drive 0 and 1); 1 = open drain (drive 0 float for 1). |
| [4] | OD4 | RW | 0 | GPIO4 Drive Mode: 0 = push-pull (drive 0 and 1); 1 = open drain (drive 0 float for 1). |
| [3] | OD3 | RW | 0 | GPIO3 Drive Mode: 0 = push-pull (drive 0 and 1); 1 = open drain (drive 0 float for 1). |

6.2.21.1. AFG GPIODrive

| Bit | Bitfield Name | RW | Reset | Description |
|-----|---------------|----|-------|--|
| [2] | OD2 | RW | 0 | GPIO2 Drive Mode: 0 = push-pull (drive 0 and 1); 1 = open drain (drive 0 float for 1). |
| [1] | OD1 | RW | 0 | GPIO1 Drive Mode: 0 = push-pull (drive 0 and 1); 1 = open drain (drive 0 float for 1). |
| [0] | OD0 | RW | 0 | GPIO0 Drive Mode: 0 = push-pull (drive 0 and 1); 1 = open-drain (drive 0 float for 1). |

6.2.22. AFG DMic

| | Verb ID | Payload | Response |
|-----|---------|---------|---------------------|
| Get | F78 | 00 | See bitfield table. |

6.2.22.1. AFG DMic

| Bit | Bitfield Name | RW | Reset | Description |
|---------|---------------|----|---------|---|
| [31..6] | Rsvd | R | 0000000 | Reserved. |
| [5] | Mono1 | RW | 0 | DMic1 mono select: 0 = stereo operation, 1 = mono operation (left channel duplicated to the right channel). |
| [4] | Mono0 | RW | 0 | DMic0 mono select: 0 = stereo operation, 1 = mono operation (left channel duplicated to the right channel). |
| [3..2] | PhAdj | RW | 0 | Selects what phase of the DMic clock the data should be latched: 0h = left data rising edge/right data falling edge; 1h = left data center of high/right data center of low; 2h = left data falling edge/right data rising edge; 3h = left data center of low/right data center of high |
| [1..0] | Rate | RW | 2 | Selects the DMic clock rate: 0h = 4.704MHz; 1h = 3.528MHz; 2h = 2.352MHz; 3h = 1.176MHz. |

6.2.23. AFG AnaBeep

| | Verb ID | Payload | Response |
|-----|---------|---------|---------------------|
| Get | FEE | 00 | See bitfield table. |

6.2.23.1. AFG AnaBeep

| Bit | Bitfield Name | RW | Reset | Description |
|---------|---------------|----|---------|---|
| [31..3] | Rsvd | R | 0000000 | Reserved. |
| [2:1] | Gain | RW | 3 | Analog PCBeep Gain 0h=-18dB 1h=-12dB 2h=-6dB 3h=0dB |
| [0] | Enable | RW | 0 | Analog PCBeep enable 1=Analog PC Beep enabled 0=disabled |

6.3. Port A Node (NID = 0A)**6.3.1. PortA WCap**

| | Verb ID | Payload | Response |
|-----|---------|---------|---------------------|
| Get | F00 | 09 | See bitfield table. |

6.3.1.1. PortA WCap

| Bit | Bitfield Name | RW | Reset | Description |
|----------|---------------|----|-------|---|
| [31..24] | Rsvd2 | R | 00 | Reserved. |
| [23..20] | Type | R | 4 | Widget type: 0h = Out Converter; 1h = In Converter; 2h = Summing (Mixer); 3h = Selector (Mux); 4h = Pin Complex; 5h = Power; 6h = Volume Knob; 7h = Beep Generator; 8h-Eh = Reserved; Fh = Vendor Defined |

6.3.1.1. *PortA WCap*

| Bit | Bitfield Name | RW | Reset | Description |
|----------|---------------|----|-------|---|
| [19.:16] | Delay | R | 0 | Number of sample delays through widget. |
| [15.:12] | Rsvd1 | R | 0 | Reserved. |
| [11] | SwapCap | R | 0 | Left/right swap support: 1 = yes 0 = no. |
| [10] | PwrCntrl | R | 0 | Power state support: 1 = yes 0 = no. |
| [9] | Dig | R | 0 | Digital stream support: 1 = yes (digital) 0 = no (analog). |
| [8] | ConnList | R | 1 | Connection list present: 1 = yes 0 = no. |
| [7] | UnSolCap | R | 1 | Unsolicited response support: 1 = yes 0 = no. |
| [6] | ProcWidget | R | 0 | Processing state support: 1 = yes 0 = no. |
| [5] | Stripe | R | 0 | Striping support: 1 = yes 0 = no. |
| [4] | FormatOvrd | R | 0 | Stream format override: 1 = yes 0 = no. |
| [3] | AmpParOvrd | R | 0 | Amplifier capabilities override: 1 = yes no. |
| [2] | OutAmpPrsnt | R | 0 | Output amp present: 1 = yes 0 = no. |
| [1] | InAmpPrsnt | R | 1 | Input amp present: 1 = yes 0 = no. |
| [0] | Stereo | R | 1 | Stereo stream support: 1 = yes (stereo) 0 = no (mono). |

6.3.2. *PortA PinCap*

| | Verb ID | Payload | Response |
|-----|---------|---------|---------------------|
| Get | F00 | 0C | See bitfield table. |

6.3.2.1. *PortA PinCap*

| Bit | Bitfield Name | RW | Reset | Description |
|----------|---------------|----|-------|--|
| [31.:17] | Rsvd2 | R | 0000 | Reserved. |
| [16] | EapdCap | R | 0 | EAPD support: 1 = yes 0 = no. |
| [15.:8] | VrefCntrl | R | 00 | Vref support: bit 7 = Reserved; bit 6 = Reserved; bit 5 = 100% support (1 = yes 0 = no); bit 4 = 80% support (1 = yes 0 = no); bit 3 = Reserved; bit 2 = GND support (1 = yes 0 = no); bit 1 = 50% support (1 = yes 0 = no); bit 0 = Hi-Z support (1 = yes 0 = no) |
| [7] | Rsvd1 | R | 0 | Reserved. |
| [6] | BalancedIO | R | 0 | Balanced I/O support: 1 = yes 0 = no. |
| [5] | InCap | R | 1 | Input support: 1 = yes 0 = no. |
| [4] | OutCap | R | 1 | Output support: 1 = yes 0 = no. |
| [3] | HdphDrvCap | R | 1 | Headphone amp present: 1 = yes 0 = no. |
| [2] | PresDtctCap | R | 1 | Presence detection support: 1 = yes 0 = no. |
| [1] | TrigRqd | R | 0 | Trigger required for impedance sense: 1 = yes 0 = no. |
| [0] | ImpSenseCap | R | 0 | Impedance sense support: 1 = yes 0 = no. |

6.3.3. *PortA ConLst*

| | Verb ID | Payload | Response |
|-----|---------|---------|---------------------|
| Get | F00 | 0E | See bitfield table. |

6.3.3.1. *PortA ConLst*

| Bit | Bitfield Name | RW | Reset | Description |
|---------|---------------|----|--------|--|
| [31..8] | Rsvd | R | 000000 | Reserved. |
| [7] | LForm | R | 0 | Connection list format: 1 = long-form (15-bit) NID entries 0 = short-form (7-bit) NID entries. |
| [6..0] | ConL | R | 03 | Number of NID entries in connection list. |

6.3.4. *PortA ConLstEntry0*

| | Verb ID | Payload | Response |
|-----|---------|---------|---------------------|
| Get | F02 | 00 | See bitfield table. |

6.3.4.1. *PortA ConLstEntry0*

| Bit | Bitfield Name | RW | Reset | Description |
|----------|---------------|----|-------|--|
| [31..24] | ConL3 | R | 00 | Unused list entry. |
| [23..16] | ConL2 | R | 1E | InputMixer Summing widget (0x1E) |
| [15] | ConL1Range | R | 1 | 1 = ConL0..ConL1 defines a range of selectable inputs. |
| [14..8] | ConL1 | R | 19 | DAC1 Converter widget (0x19) |
| [7..0] | ConL0 | R | 15 | DAC0 Converter widget (0x15) |

6.3.5. *PortA ConSelectCtrl*

| | Verb ID | Payload | Response |
|-----|---------|---------|---------------------|
| Get | F01 | 00 | See bitfield table. |

6.3.5.1. *PortA ConSelectCtrl*

| Bit | Bitfield Name | RW | Reset | Description |
|---------|---------------|----|----------|----------------------------------|
| [31..2] | Rsvd | R | 00000000 | Reserved. |
| [1..0] | Index | RW | 0 | Connection select control index. |

6.3.6. *PortA PinWCntrl*

| | Verb ID | Payload | Response |
|-----|---------|---------|---------------------|
| Get | F07 | 00 | See bitfield table. |

6.3.6.1. *PortA PinWCntrl*

| Bit | Bitfield Name | RW | Reset | Description |
|---------|---------------|----|--------|---|
| [31..8] | Rsvd2 | R | 000000 | Reserved. |
| [7] | HPhnEn | RW | 0 | Headphone amp enable: 1 = enabled 0 = disabled. |
| [6] | OutEn | RW | 0 | Output enable: 1 = enabled 0 = disabled. |
| [4..3] | Rsvd1 | R | 0 | Reserved. |
| [2..0] | VRefEn | RW | 0 | Vref selection (See VrefCntrl field of PinCap parameter for supported selections): 000b= HI-Z, 001b= 50% 010b= GND, 011b= Reserved 100b= 80%, 101b= 100% 110b= Reserved, 111b= Reserved |

6.3.7. *PortA UnsolResp*

| | Verb ID | Payload | Response |
|-----|---------|---------|---------------------|
| Get | F08 | 00 | See bitfield table. |

6.3.7.1. *PortA UnsolResp*

| Bit | Bitfield Name | RW | Reset | Description |
|---------|---------------|----|--------|--|
| [31..8] | Rsvd2 | R | 000000 | Reserved. |
| [7] | En | RW | 0 | Unsolicited response enable: 1 = enabled 0 = disabled. |
| [6] | Rsvd1 | R | 0 | Reserved. |
| [5..0] | Tag | RW | 00 | Software programmable field returned in top six bits (31:26) of every Unsolicited Response generated by this node. |

6.3.8. *PortA ChSense*

| | Verb ID | Payload | Response |
|-----|---------|---------|---------------------|
| Get | F09 | 00 | See bitfield table. |

6.3.8.1. *PortA ChSense*

| Bit | Bitfield Name | RW | Reset | Description |
|---------|---------------|----|----------|---|
| [31] | PresDtct | R | 0 | Presence detection indicator: 1 = presence detected; 0 = presence not detected. |
| [30..1] | Impedence | R | 3FFFFFFF | Impedance Sense Value (Bits 30:1): Measured impedance of the widget. An all ones value indicates an invalid sense reading |
| [0] | Execute | RW | 1 | Impedance Sense Value (Bit 0)/Trigger: Read = Impedance value bit 0 Write 0 = Impedance sense occurs using left channel Write 1 = Impedance sense occurs using right channel |

6.3.9. PortA InAmpLeft

| | Verb ID | Payload | Response |
|-----|---------|---------|---------------------|
| Get | B20 | 00 | See bitfield table. |

6.3.9.1. PortA InAmpLeft

| Bit | Bitfield Name | RW | Reset | Description |
|---------|---------------|----|----------|--|
| [31..2] | Rsvd1 | R | 00000000 | Reserved. |
| [1..0] | Gain | RW | 0 | Amp gain step number (see InAmpCap parameter pertaining to this widget). |

6.3.10. PortA InAmpRight

| | Verb ID | Payload | Response |
|-----|---------|---------|---------------------|
| Get | B00 | 00 | See bitfield table. |

6.3.10.1. PortA InAmpRight

| Bit | Bitfield Name | RW | Reset | Description |
|---------|---------------|----|----------|--|
| [31..2] | Rsvd1 | R | 00000000 | Reserved. |
| [1..0] | Gain | RW | 0 | Amp gain step number (see InAmpCap parameter pertaining to this widget). |

6.3.11. PortA ConfigDefault

| | Verb ID | Payload | Response |
|-----|---------|---------|---------------------|
| Get | F1C | 00 | See bitfield table. |

6.3.11.1. PortA ConfigDefault

| Bit | Bitfield Name | RW | Reset | Description |
|----------|------------------|----|-------|--|
| [31.:30] | PortConnectivity | RW | 0 | Port connectivity: 0h = Port complex is connected to a jack; 1h = No physical connection for port; 2h = Fixed function device is attached; 3h = Both jack and internal device attached (info in all other fields refers to integrated device any presence detection refers to jack) |
| [29.:24] | Location | RW | 02 | Location. Bits [5..4]: 0h = External on primary chassis; 1h = Internal; 2h = Separate chassis; 3h = Other. Bits [3..0]: 0h = N/A; 1h = Rear; 2h = Front; 3h = Left; 4h = Right; 5h = Top; 6h = Bottom; 7h-9h = Special; Ah-Fh = Reserved |
| [23.:20] | Device | RW | 2 | Default device: 0h = Line out; 1h = Speaker; 2h = HP out; 3h = CD; 4h = SPDIF Out; 5h = Digital other out; 6h = Modem line side; 7h = Modem handset side; 8h = Line in; 9h = Aux; Ah = Mic in; Bh = Telephony; Ch = SPDIF In; Dh = Digital other in; Eh = Reserved; Fh = Other |
| [19.:16] | Connection Type | RW | 1 | Connection type: 0h = Unknown; 1h = 1/8" stereo/mono; 2h = 1/4" stereo/mono; 3h = ATAPI internal; 4h = RCA; 5h = Optical; 6h = Other digital; 7h = Other analog; 8h = Multichannel analog (DIN); 9h = XLR/Professional; Ah = RJ-11 (modem); Bh = Combination; Ch-Eh = Reserved; Fh = Other |
| [15.:12] | Color | RW | 4 | Color: 0h = Unknown; 1h = Black; 2h = Grey; 3h = Blue; 4h = Green; 5h = Red; 6h = Orange; 7h = Yellow; 8h = Purple; 9h = Pink; Ah-Dh = Reserved; Eh = White; Fh = Other |
| [11.:8] | Misc | RW | 0 | Miscellaneous: Bits [3..1] = Reserved; Bit 0 = Jack detect override |
| [7.:4] | Association | RW | 3 | Default association. |
| [3.:0] | Sequence | RW | 0 | Sequence. |

6.4. PortB Node (NID = 0B)

6.4.1. PortB WCap

| | Verb ID | Payload | Response |
|-----|---------|---------|---------------------|
| Get | F00 | 09 | See bitfield table. |

6.4.1.1. PortB WCap

| Bit | Bitfield Name | RW | Reset | Description |
|----------|---------------|----|-------|---|
| [31..24] | Rsvd2 | R | 00 | Reserved. |
| [23..20] | Type | R | 4 | Widget type: 0h = Out Converter; 1h = In Converter; 2h = Summing (Mixer); 3h = Selector (Mux); 4h = Pin Complex; 5h = Power; 6h = Volume Knob; 7h = Beep Generator; 8h-Eh = Reserved; Fh = Vendor Defined |
| [19..16] | Delay | R | 0 | Number of sample delays through widget. |
| [15..12] | Rsvd1 | R | 0 | Reserved. |
| [11] | SwapCap | R | 0 | Left/right swap support: 1 = yes 0 = no. |
| [10] | PwrCntrl | R | 0 | Power state support: 1 = yes 0 = no. |
| [9] | Dig | R | 0 | Digital stream support: 1 = yes (digital) 0 = no (analog). |
| [8] | ConnList | R | 1 | Connection list present: 1 = yes 0 = no. |
| [7] | UnSolCap | R | 1 | Unsolicited response support: 1 = yes 0 = no. |
| [6] | ProcWidget | R | 0 | Processing state support: 1 = yes 0 = no. |
| [5] | Stripe | R | 0 | Striping support: 1 = yes 0 = no. |
| [4] | FormatOvrd | R | 0 | Stream format override: 1 = yes 0 = no. |
| [3] | AmpParOvrd | R | 0 | Amplifier capabilities override: 1 = yes no. |
| [2] | OutAmpPrsnt | R | 0 | Output amp present: 1 = yes 0 = no. |

6.4.1.1. *PortB WCap*

| Bit | Bitfield Name | RW | Reset | Description |
|-----|---------------|----|-------|---|
| [1] | InAmpPrsnt | R | 1 | Input amp present: 1 = yes 0 = no. |
| [0] | Stereo | R | 1 | Stereo stream support: 1 = yes (stereo) 0 = no (mono). |

6.4.2. *PortB PinCap*

| | Verb ID | Payload | Response |
|-----|---------|---------|---------------------|
| Get | F00 | 0C | See bitfield table. |

6.4.2.1. *PortB PinCap*

| Bit | Bitfield Name | RW | Reset | Description |
|----------|---------------|----|-------|--|
| [31.:17] | Rsvd2 | R | 0000 | Reserved. |
| [16] | EapdCap | R | 0 | EAPD support: 1 = yes 0 = no. |
| [15.:8] | VrefCntrl | R | 17 | Vref support: bit 7 = Reserved; bit 6 = Reserved; bit 5 = 100% support (1 = yes 0 = no); bit 4 = 80% support (1 = yes 0 = no); bit 3 = Reserved; bit 2 = GND support (1 = yes 0 = no); bit 1 = 50% support (1 = yes 0 = no); bit 0 = Hi-Z support (1 = yes 0 = no) |
| [7] | Rsvd1 | R | 0 | Reserved. |
| [6] | BalancedIO | R | 0 | Balanced I/O support: 1 = yes 0 = no. |
| [5] | InCap | R | 1 | Input support: 1 = yes 0 = no. |
| [4] | OutCap | R | 1 | Output support: 1 = yes 0 = no. |
| [3] | HdphDrvCap | R | 1 | Headphone amp present: 1 = yes 0 = no. |
| [2] | PresDtctCap | R | 1 | Presence detection support: 1 = yes 0 = no. |

6.4.2.1. *PortB PinCap*

| Bit | Bitfield Name | RW | Reset | Description |
|-----|---------------|----|-------|--|
| [1] | TrigRqd | R | 1 | Trigger required for impedance sense: 1 = yes 0 = no. |
| [0] | ImpSenseCap | R | 1 | Impedance sense support: 1 = yes 0 = no. |

6.4.3. *PortB ConLstEntry0*

| | Verb ID | Payload | Response |
|-----|---------|---------|---------------------|
| Get | F00 | 0E | See bitfield table. |

6.4.3.1. *PortB ConLst*

| Bit | Bitfield Name | RW | Reset | Description |
|---------|---------------|----|--------|--|
| [31..8] | Rsvd | R | 000000 | Reserved. |
| [7] | LForm | R | 0 | Connection list format: 1 = long-form (15-bit) NID entries 0 = short-form (7-bit) NID entries. |
| [6..0] | ConL | R | 03 | Number of NID entries in connection list. |

6.4.4. *PortB ConLstEntry0*

| | Verb ID | Payload | Response |
|-----|---------|---------|---------------------|
| Get | F02 | 00 | See bitfield table. |

6.4.4.1. *PortB ConLstEntry0*

| Bit | Bitfield Name | RW | Reset | Description |
|----------|---------------|----|-------|--|
| [31.:24] | ConL3 | R | 00 | Unused list entry. |
| [23.:16] | ConL2 | R | 1E | MixerOutVol Selector widget (0x1E) |
| [15] | ConL1Range | R | 1 | 1 = ConL0..ConL1 defines a range of selectable inputs. |
| [14.:8] | ConL1 | R | 17 | DAC2 Converter widget (0x17) |
| [7.:0] | ConL0 | R | 15 | DAC0 Converter widget (0x15) |

6.4.5. *PortB ConSelectCtrl*

| | Verb ID | Payload | Response |
|-----|---------|---------|---------------------|
| Get | F01 | 00 | See bitfield table. |

6.4.5.1. *PortB ConSelectCtrl*

| Bit | Bitfield Name | RW | Reset | Description |
|---------|---------------|----|----------|----------------------------------|
| [31.:2] | Rsvd | R | 00000000 | Reserved. |
| [1.:0] | Index | RW | 0 | Connection select control index. |

6.4.6. *PortB PinWCntrl*

| | Verb ID | Payload | Response |
|-----|---------|---------|---------------------|
| Get | F07 | 00 | See bitfield table. |

6.4.6.1. *PortB PinWCntrl*

| Bit | Bitfield Name | RW | Reset | Description |
|---------|---------------|----|---------|--|
| [31..8] | Rsvd2 | R | 0000000 | Reserved. |
| [7] | HPhnEn | RW | 0 | Headphone amp enable: 1 = enabled, 0 = disabled. |
| [6] | OutEn | RW | 0 | Output enable: 1 = enabled, 0 = disabled. |
| [5] | InEn | RW | 0 | Input enable: 1 = enabled 0 = disabled. |
| [4..3] | Rsvd1 | R | 0 | Reserved. |
| [2..0] | VRefEn | RW | 0 | Vref selection (See VrefCntrl field of PinCap parameter for supported selections): 000b= HI-Z; 001b= 50%; 010b= GND; 011b= Reserved; 100b= 80%; 101b= 100%; 110b= Reserved; 111b= Reserved |

6.4.7. *PortB UnsolicitedResp*

| | Verb ID | Payload | Response |
|-----|---------|---------|---------------------|
| Get | F08 | 00 | See bitfield table. |

6.4.7.1. *PortB UnsolicitedResp*

| Bit | Bitfield Name | RW | Reset | Description |
|---------|---------------|----|---------|--|
| [31..8] | Rsvd2 | R | 0000000 | Reserved. |
| [7] | En | RW | 0 | Unsolicited response enable: 1 = enabled 0 = disabled. |
| [6] | Rsvd1 | R | 0 | Reserved. |
| [5..0] | Tag | RW | 00 | Software programmable field returned in top six bits (31:26) of every Unsolicited Response generated by this node. |

6.4.8. PortB ChSense

| | Verb ID | Payload | Response |
|-----|---------|---------|---------------------|
| Get | F09 | 00 | See bitfield table. |

6.4.8.1. PortB ChSense

| Bit | Bitfield Name | RW | Reset | Description |
|---------|---------------|----|----------|---|
| [31] | PresDtct | R | 0 | Presence detection indicator: 1 = presence detected; 0 = presence not detected. |
| [30.:1] | Impedence | R | 3FFFFFFF | Impedance Sense Value (Bits 30:1): Measured impedance of the widget. An all ones value indicates an invalid sense reading |
| [0] | Execute | RW | 1 | Impedance Sense Value (Bit 0)/Trigger: Read = Impedance value bit 0 Write 0 = Impedance sense occurs using left channel Write 1 = Impedance sense occurs using right channel |

6.4.9. PortB InAmpLeft

| | Verb ID | Payload | Response |
|-----|---------|---------|---------------------|
| Get | B20 | 00 | See bitfield table. |

6.4.9.1. PortB InAmpLeft

| Bit | Bitfield Name | RW | Reset | Description |
|---------|---------------|----|--------|--|
| [31.:2] | Rsvd1 | R | 000000 | Reserved. |
| [1.:0] | Gain | RW | 0 | Amp gain step number (see InAmpCap parameter pertaining to this widget). |

6.4.10. PortD InAmpRight

| | Verb ID | Payload | Response |
|-----|---------|---------|---------------------|
| Get | B00 | 00 | See bitfield table. |

6.4.10.1. PortD InAmpRight

| Bit | Bitfield Name | RW | Reset | Description |
|---------|---------------|----|--------|--|
| [31..2] | Rsvd1 | R | 000000 | Reserved. |
| [1..0] | Gain | RW | 0 | Amp gain step number (see InAmpCap parameter pertaining to this widget). |

6.4.11. PortB ConfigDefault

| | Verb ID | Payload | Response |
|-----|---------|---------|---------------------|
| Get | F1C | 00 | See bitfield table. |

6.4.11.1. PortB ConfigDefault

| Bit | Bitfield Name | RW | Reset | Description |
|----------|------------------|----|-------|---|
| [31..30] | PortConnectivity | RW | 0 | Port connectivity: 0h = Port complex is connected to a jack; 1h = No physical connection for port; 2h = Fixed function device is attached; 3h = Both jack and internal device attached (info in all other fields refers to integrated device any presence detection refers to jack) |
| [29..24] | Location | RW | 02 | Location. Bits [5..4]: 0h = External on primary chassis; 1h = Internal; 2h = Separate chassis; 3h = Other. Bits [3..0]: 0h = N/A; 1h = Rear; 2h = Front; 3h = Left; 4h = Right; 5h = Top; 6h = Bottom; 7h-9h = Special; Ah-Fh = Reserved |

6.4.11.1. *PortB ConfigDefault*

| Bit | Bitfield Name | RW | Reset | Description |
|----------|----------------|----|-------|--|
| [23.:20] | Device | RW | A | Default device: 0h = Line out; 1h = Speaker; 2h = HP out; 3h = CD; 4h = SPDIF Out; 5h = Digital other out; 6h = Modem line side; 7h = Modem handset side; 8h = Line in; 9h = Aux; Ah = Mic in; Bh = Telephony; Ch = SPDIF In; Dh = Digital other in; Eh = Reserved; Fh = Other |
| [19.:16] | ConnectionType | RW | 1 | Connection type: 0h = Unknown; 1h = 1/8" stereo/mono; 2h = 1/4" stereo/mono; 3h = ATAPI internal; 4h = RCA; 5h = Optical; 6h = Other digital; 7h = Other analog; 8h = Multichannel analog (DIN); 9h = XLR/Professional; Ah = RJ-11 (modem); Bh = Combination; Ch-Eh = Reserved; Fh = Other |
| [15.:12] | Color | RW | 9 | Color: 0h = Unknown; 1h = Black; 2h = Grey; 3h = Blue; 4h = Green; 5h = Red; 6h = Orange; 7h = Yellow; 8h = Purple; 9h = Pink; Ah-Dh = Reserved; Eh = White; Fh = Other |
| [11.:8] | Misc | RW | 0 | Miscellaneous: Bits [3..1] = Reserved; Bit 0 = Jack detect override |
| [7.:4] | Association | RW | 4 | Default association. |
| [3.:0] | Sequence | RW | 0 | Sequence. |

6.5. **Port C Node (NID = 0C)**6.5.1. *PortC WCap*

| | Verb ID | Payload | Response |
|-----|---------|---------|---------------------|
| Get | F00 | 09 | See bitfield table. |

6.5.1.1. PortC WCap

| Bit | Bitfield Name | RW | Reset | Description |
|----------|---------------|----|-------|---|
| [31.:24] | Rsvd2 | R | 00 | Reserved. |
| [23.:20] | Type | R | 4 | Widget type: 0h = Out Converter; 1h = In Converter; 2h = Summing (Mixer); 3h = Selector (Mux); 4h = Pin Complex; 5h = Power; 6h = Volume Knob; 7h = Beep Generator; 8h-Eh = Reserved; Fh = Vendor Defined |
| [19.:16] | Delay | R | 0 | Number of sample delays through widget. |
| [15.:12] | Rsvd1 | R | 0 | Reserved. |
| [11] | SwapCap | R | 0 | Left/right swap support: 1 = yes 0 = no. |
| [10] | PwrCntrl | R | 0 | Power state support: 1 = yes 0 = no. |
| [9] | Dig | R | 0 | Digital stream support: 1 = yes (digital) 0 = no (analog). |
| [8] | ConnList | R | 1 | Connection list present: 1 = yes 0 = no. |
| [7] | UnSolCap | R | 1 | Unsolicited response support: 1 = yes 0 = no. |
| [6] | ProcWidget | R | 0 | Processing state support: 1 = yes 0 = no. |
| [5] | Stripe | R | 0 | Striping support: 1 = yes 0 = no. |
| [4] | FormatOvrd | R | 0 | Stream format override: 1 = yes 0 = no. |
| [3] | AmpParOvrd | R | 0 | Amplifier capabilities override: 1 = yes no. |
| [2] | OutAmpPrsnt | R | 0 | Output amp present: 1 = yes 0 = no. |
| [1] | InAmpPrsnt | R | 1 | Input amp present: 1 = yes 0 = no. |
| [0] | Stereo | R | 1 | Stereo stream support: 1 = yes (stereo) 0 = no (mono). |

6.5.2. PortC PinCap

| | Verb ID | Payload | Response |
|-----|---------|---------|---------------------|
| Get | F00 | 0C | See bitfield table. |

6.5.2.1. PortC PinCap

| Bit | Bitfield Name | RW | Reset | Description |
|----------|---------------|----|-------|--|
| [31.:17] | Rsvd2 | R | 0000 | Reserved. |
| [16] | EapdCap | R | 0 | EAPD support: 1 = yes 0 = no. |
| [15.:8] | VrefCntrl | R | 17 | Vref support: bit 7 = Reserved; bit 6 = Reserved; bit 5 = 100% support (1 = yes 0 = no); bit 4 = 80% support (1 = yes 0 = no); bit 3 = Reserved; bit 2 = GND support (1 = yes 0 = no); bit 1 = 50% support (1 = yes 0 = no); bit 0 = Hi-Z support (1 = yes 0 = no) |
| [7] | Rsvd1 | R | 0 | Reserved. |
| [6] | BalancedIO | R | 0 | Balanced I/O support: 1 = yes 0 = no. |
| [5] | InCap | R | 1 | Input support: 1 = yes 0 = no. |
| [4] | OutCap | R | 1 | Output support: 1 = yes 0 = no. |
| [3] | HdphDrvCap | R | 0 | Headphone amp present: 1 = yes 0 = no. |
| [2] | PresDtctCap | R | 1 | Presence detection support: 1 = yes 0 = no. |
| [1] | TrigRqd | R | 1 | Trigger required for impedance sense: 1 = yes 0 = no. |
| [0] | ImpSenseCap | R | 1 | Impedance sense support: 1 = yes 0 = no. |

6.5.3. PortC ConLst

| | Verb ID | Payload | Response |
|-----|---------|---------|---------------------|
| Get | F00 | 0E | See bitfield table. |

6.5.3.1. PortC ConLst

| Bit | Bitfield Name | RW | Reset | Description |
|---------|---------------|----|--------|--|
| [31..8] | Rsvd | R | 000000 | Reserved. |
| [7] | LForm | R | 0 | Connection list format: 1 = long-form (15-bit) NID entries 0 = short-form (7-bit) NID entries. |
| [6..0] | ConL | R | 03 | Number of NID entries in connection list. |

6.5.4. PortC ConLstEntry0

| | Verb ID | Payload | Response |
|-----|---------|---------|---------------------|
| Get | F02 | 00 | See bitfield table. |

6.5.4.1. PortC ConLstEntry0

| Bit | Bitfield Name | RW | Reset | Description |
|----------|---------------|----|-------|--|
| [31..24] | ConL3 | R | 00 | Unused list entry. |
| [23..16] | ConL2 | R | 17 | InputMixer Summing widget (0x1E) |
| [15] | ConL1Range | R | 1 | 1 = ConL0..ConL1 defines a range of selectable inputs. |
| [14..8] | ConL1 | R | 17 | DAC2 Converter widget (0x17) |
| [7..0] | ConL0 | R | 15 | DAC0 Converter widget (0x15) |

6.5.5. PortC ConSelectCtrl

| | Verb ID | Payload | Response |
|-----|---------|---------|---------------------|
| Get | F01 | 00 | See bitfield table. |

6.5.5.1. PortC ConSelectCtrl

| Bit | Bitfield Name | RW | Reset | Description |
|---------|---------------|----|----------|----------------------------------|
| [31..2] | Rsvd | R | 00000000 | Reserved. |
| [1..0] | Index | RW | 0 | Connection select control index. |

6.5.6. PortC PinWCntrl

| | Verb ID | Payload | Response |
|-----|---------|---------|---------------------|
| Get | F07 | 00 | See bitfield table. |

6.5.6.1. PortC PinWCntrl

| Bit | Bitfield Name | RW | Reset | Description |
|---------|---------------|----|----------|--|
| [31..6] | Rsvd2 | R | 00000000 | Reserved. |
| [5] | InEn | RW | 0 | Input enable: 1 = enabled 0 = disabled. |
| [4..3] | Rsvd1 | R | 0 | Reserved. |
| [2..0] | VRefEn | RW | 0 | Vref selection (See VrefCntrl field of PinCap parameter for supported selections): 000b= HI-Z; 001b= 50%; 010b= GND; 011b= Reserved; 100b= 80%; 101b= 100%; 110b= Reserved; 111b= Reserved |

6.5.7. PortC UnsolResp

| | Verb ID | Payload | Response |
|-----|---------|---------|---------------------|
| Get | F08 | 00 | See bitfield table. |

6.5.7.1. PortC UnsolResp

| Bit | Bitfield Name | RW | Reset | Description |
|---------|---------------|----|--------|--|
| [31..8] | Rsvd2 | R | 000000 | Reserved. |
| [7] | En | RW | 0 | Unsolicited response enable: 1 = enabled 0 = disabled. |
| [6] | Rsvd1 | R | 0 | Reserved. |
| [5..0] | Tag | RW | 00 | Software programmable field returned in top six bits (31:26) of every Unsolicited Response generated by this node. |

6.5.8. PortC ChSense

| | Verb ID | Payload | Response |
|-----|---------|---------|---------------------|
| Get | F09 | 00 | See bitfield table. |

6.5.8.1. PortC ChSense

| Bit | Bitfield Name | RW | Reset | Description |
|------|---------------|----|-------|---|
| [31] | PresDtct | R | 0 | Presence detection indicator: 1 = presence detected; 0 = presence not detected. |

6.5.8.1. *PortC ChSense*

| Bit | Bitfield Name | RW | Reset | Description |
|---------|---------------|----|----------|---|
| [30.:1] | Impedence | R | 3FFFFFFF | Impedance Sense Value (Bits 30:1): Measured impedance of the widget. An all ones value indicates an invalid sense reading |
| [0] | Execute | RW | 1 | Impedance Sense Value (Bit 0)/Trigger: Read = Impedance value bit 0 Write 0 = Impedance sense occurs using left channel Write 1 = Impedance sense occurs using right channel |

6.5.9. *PortC InAmpLeft*

| | Verb ID | Payload | Response |
|-----|---------|---------|---------------------|
| Get | B20 | 00 | See bitfield table. |

6.5.9.1. *PortC InAmpLeft*

| Bit | Bitfield Name | RW | Reset | Description |
|---------|---------------|----|----------|--|
| [31.:2] | Rsvd1 | R | 00000000 | Reserved. |
| [1.:0] | Gain | RW | 0 | Amp gain step number (see InAmpCap parameter pertaining to this widget). |

6.5.10. *PortC InAmpRight*

| | Verb ID | Payload | Response |
|-----|---------|---------|---------------------|
| Get | B00 | 00 | See bitfield table. |

6.5.10.1. *PortC InAmpRight*

| Bit | Bitfield Name | RW | Reset | Description |
|---------|---------------|----|----------|--|
| [31..2] | Rsvd1 | R | 00000000 | Reserved. |
| [1..0] | Gain | RW | 0 | Amp gain step number (see InAmpCap parameter pertaining to this widget). |

6.5.11. *PortC ConfigDefault*

| | Verb ID | Payload | Response |
|-----|---------|---------|---------------------|
| Get | F1C | 00 | See bitfield table. |

6.5.11.1. *PortC ConfigDefault*

| Bit | Bitfield Name | RW | Reset | Description |
|----------|------------------|----|-------|---|
| [31..30] | PortConnectivity | RW | 0 | Port connectivity: 0h = Port complex is connected to a jack; 1h = No physical connection for port; 2h = Fixed function device is attached; 3h = Both jack and internal device attached (info in all other fields refers to integrated device any presence detection refers to jack) |
| [29..24] | Location | RW | 1 | Location. Bits [5..4]: 0h = External on primary chassis; 1h = Internal; 2h = Separate chassis; 3h = Other. Bits [3..0]: 0h = N/A; 1h = Rear; 2h = Front; 3h = Left; 4h = Right; 5h = Top; 6h = Bottom; 7h-9h = Special; Ah-Fh = Reserved |

6.5.11.1. *PortC ConfigDefault*

| Bit | Bitfield Name | RW | Reset | Description |
|----------|----------------|----|-------|--|
| [23.:20] | Device | RW | 8 | Default device: 0h = Line out; 1h = Speaker; 2h = HP out; 3h = CD; 4h = SPDIF Out; 5h = Digital other out; 6h = Modem line side; 7h = Modem handset side; 8h = Line in; 9h = Aux; Ah = Mic in; Bh = Telephony; Ch = SPDIF In; Dh = Digital other in; Eh = Reserved; Fh = Other |
| [19.:16] | ConnectionType | RW | 1 | Connection type: 0h = Unknown; 1h = 1/8" stereo/mono; 2h = 1/4" stereo/mono; 3h = ATAPI internal; 4h = RCA; 5h = Optical; 6h = Other digital; 7h = Other analog; 8h = Multichannel analog (DIN); 9h = XLR/Professional; Ah = RJ-11 (modem); Bh = Combination; Ch-Eh = Reserved; Fh = Other |
| [15.:12] | Color | RW | 3 | Color: 0h = Unknown; 1h = Black; 2h = Grey; 3h = Blue; 4h = Green; 5h = Red; 6h = Orange; 7h = Yellow; 8h = Purple; 9h = Pink; Ah-Dh = Reserved; Eh = White; Fh = Other |
| [11.:8] | Misc | RW | 0 | Miscellaneous: Bits [3..1] = Reserved; Bit 0 = Jack detect override |
| [7.:4] | Association | RW | 2 | Default association. |
| [3.:0] | Sequence | RW | 1 | Sequence. |

6.6. Port D Node (NID = 0D)

6.6.1. *PortD WCap*

| | Verb ID | Payload | Response |
|-----|---------|---------|---------------------|
| Get | F00 | 09 | See bitfield table. |

6.6.1.1. *PortD WCap*

| Bit | Bitfield Name | RW | Reset | Description |
|----------|---------------|----|-------|---|
| [31.:24] | Rsvd2 | R | 00 | Reserved. |
| [23.:20] | Type | R | 4 | Widget type: 0h = Out Converter; 1h = In Converter; 2h = Summing (Mixer); 3h = Selector (Mux); 4h = Pin Complex; 5h = Power; 6h = Volume Knob; 7h = Beep Generator; 8h-Eh = Reserved; Fh = Vendor Defined |
| [19.:16] | Delay | R | 0 | Number of sample delays through widget. |
| [15.:12] | Rsvd1 | R | 0 | Reserved. |
| [11] | SwapCap | R | 0 | Left/right swap support: 1 = yes 0 = no. |
| [10] | PwrCntrl | R | 0 | Power state support: 1 = yes 0 = no. |
| [9] | Dig | R | 0 | Digital stream support: 1 = yes (digital) 0 = no (analog). |
| [8] | ConnList | R | 1 | Connection list present: 1 = yes 0 = no. |
| [7] | UnSolCap | R | 1 | Unsolicited response support: 1 = yes 0 = no. |
| [6] | ProcWidget | R | 0 | Processing state support: 1 = yes 0 = no. |
| [5] | Stripe | R | 0 | Striping support: 1 = yes 0 = no. |
| [4] | FormatOvrd | R | 0 | Stream format override: 1 = yes 0 = no. |
| [3] | AmpParOvrd | R | 1 | Amplifier capabilities override: 1 = yes no. |
| [2] | OutAmpPrsnt | R | 1 | Output amp present: 1 = yes 0 = no. |
| [1] | InAmpPrsnt | R | 1 | Input amp present: 1 = yes 0 = no. |
| [0] | Stereo | R | 1 | Stereo stream support: 1 = yes (stereo) 0 = no (mono). |

6.6.2. *PortD PinCap*

| | Verb ID | Payload | Response |
|-----|---------|---------|---------------------|
| Get | F00 | 0C | See bitfield table. |

6.6.2.1. *PortD PinCap*

| Bit | Bitfield Name | RW | Reset | Description |
|----------|---------------|----|-------|--|
| [31.:17] | Rsvd2 | R | 0000 | Reserved. |
| [16] | EapdCap | R | 0 | EAPD support: 1 = yes 0 = no. |
| [15.:8] | VrefCntrl | R | 00 | Vref support: bit 7 = Reserved; bit 6 = Reserved; bit 5 = 100% support (1 = yes 0 = no); bit 4 = 80% support (1 = yes 0 = no); bit 3 = Reserved; bit 2 = GND support (1 = yes 0 = no); bit 1 = 50% support (1 = yes 0 = no); bit 0 = Hi-Z support (1 = yes 0 = no) |
| [7] | Rsvd1 | R | 0 | Reserved. |
| [6] | BalancedIO | R | 0 | Balanced I/O support: 1 = yes 0 = no. |
| [5] | InCap | R | 1 | Input support: 1 = yes 0 = no. |
| [4] | OutCap | R | 1 | Output support: 1 = yes 0 = no. |
| [3] | HdphDrvCap | R | 1 | Headphone amp present: 1 = yes 0 = no. |
| [2] | PresDtctCap | R | 1 | Presence detection support: 1 = yes 0 = no. |
| [1] | TrigRqd | R | 0 | Trigger required for impedance sense: 1 = yes 0 = no. |
| [0] | ImpSenseCap | R | 0 | Impedance sense support: 1 = yes 0 = no. |

6.6.3. PortD ConLst

| | Verb ID | Payload | Response |
|-----|---------|---------|---------------------|
| Get | F00 | 0E | See bitfield table. |

6.6.3.1. PortD ConLst

| Bit | Bitfield Name | RW | Reset | Description |
|---------|---------------|----|--------|--|
| [31..8] | Rsvd | R | 000000 | Reserved. |
| [7] | LForm | R | 0 | Connection list format: 1 = long-form (15-bit) NID entries 0 = short-form (7-bit) NID entries. |
| [6..0] | ConL | R | 03 | Number of NID entries in connection list. |

6.6.4. PortD ConLstEntry0

| | Verb ID | Payload | Response |
|-----|---------|---------|---------------------|
| Get | F02 | 00 | See bitfield table. |

6.6.4.1. PortD ConLstEntry0

| Bit | Bitfield Name | RW | Reset | Description |
|----------|---------------|----|-------|--|
| [31..24] | ConL3 | R | 00 | Unused list entry. |
| [23..16] | ConL2 | R | 1E | MixerOutVol Summing widget (0x1E) |
| [15] | ConL1Range | R | 1 | 1 = ConL0..ConL1 defines a range of selectable inputs. |
| [15..8] | ConL1 | R | 17 | DAC2 Converter widget (0x17) |
| [7..0] | ConL0 | R | 15 | DAC0 Converter widget (0x15) |

6.6.5. PortD ConSelectCtrl

| | Verb ID | Payload | Response |
|-----|---------|---------|---------------------|
| Get | F01 | 00 | See bitfield table. |

6.6.5.1. PortD ConSelectCtrl

| Bit | Bitfield Name | RW | Reset | Description |
|---------|---------------|----|----------|----------------------------------|
| [31..2] | Rsvd | R | 00000000 | Reserved. |
| [1..0] | Index | RW | 0 | Connection select control index. |

6.6.6. PortD PinWCntrl

| | Verb ID | Payload | Response |
|-----|---------|---------|---------------------|
| Get | F07 | 00 | See bitfield table. |

6.6.6.1. PortD PinWCntrl

| Bit | Bitfield Name | RW | Reset | Description |
|---------|---------------|----|--------|---|
| [31..8] | Rsvd2 | R | 000000 | Reserved. |
| [7] | HPhnEn | RW | 0 | Headphone amp enable: 1 = enabled, 0 = disabled. |
| [6] | OutEn | RW | 0 | Output enable: 1 = enabled 0 = disabled. |
| [5] | InEn | RW | 0 | Input enable: 1 = enabled 0 = disabled. |
| [4..0] | Rsvd1 | R | 0 | Reserved. |

6.6.7. PortD UnsolResp

| | Verb ID | Payload | Response |
|-----|---------|---------|---------------------|
| Get | F08 | 00 | See bitfield table. |

6.6.7.1. PortD UnsolResp

| Bit | Bitfield Name | RW | Reset | Description |
|---------|---------------|----|--------|--|
| [31..8] | Rsvd2 | R | 000000 | Reserved. |
| [7] | En | RW | 0 | Unsolicited response enable: 1 = enabled 0 = disabled. |
| [6] | Rsvd1 | R | 0 | Reserved. |
| [5..0] | Tag | RW | 00 | Software programmable field returned in top six bits (31:26) of every Unsolicited Response generated by this node. |

6.6.8. PortD ChSense

| | Verb ID | Payload | Response |
|-----|---------|---------|---------------------|
| Get | F09 | 00 | See bitfield table. |

6.6.8.1. PortD ChSense

| Bit | Bitfield Name | RW | Reset | Description |
|------|---------------|----|-------|---|
| [31] | PresDtct | R | 0 | Presence detection indicator: 1 = presence detected; 0 = presence not detected. |

6.6.8.1. *PortD ChSense*

| Bit | Bitfield Name | RW | Reset | Description |
|---------|---------------|----|----------|---|
| [30.:1] | Impedence | R | 3FFFFFFh | Impedance Sense Value (Bits 30:1): Measured impedance of the widget. An all ones value indicates an invalid sense reading |
| [0] | Execute | RW | 1 | Impedance Sense Value (Bit 0)/Trigger: Read = Impedance value bit 0 Write 0 = Impedance sense occurs using left channel Write 1 = Impedance sense occurs using right channel |

6.6.9. *PortD InAmpLeft*

| | Verb ID | Payload | Response |
|-----|---------|---------|---------------------|
| Get | B20 | 00 | See bitfield table. |

6.6.9.1. *PortD InAmpLeft*

| Bit | Bitfield Name | RW | Reset | Description |
|---------|---------------|----|--------|--|
| [31.:2] | Rsvd1 | R | 000000 | Reserved. |
| [1.:0] | Gain | RW | 0 | Amp gain step number (see InAmpCap parameter pertaining to this widget). |

6.6.10. *PortD InAmpRight*

| | Verb ID | Payload | Response |
|-----|---------|---------|---------------------|
| Get | B00 | 00 | See bitfield table. |

6.6.10.1. *PortD InAmpRight*

| Bit | Bitfield Name | RW | Reset | Description |
|---------|---------------|----|--------|--|
| [31..2] | Rsvd1 | R | 000000 | Reserved. |
| [1..0] | Gain | RW | 0 | Amp gain step number (see InAmpCap parameter pertaining to this widget). |

6.6.11. *PortD ConfigDefault*

| | Verb ID | Payload | Response |
|-----|---------|---------|---------------------|
| Get | F1C | 00 | See bitfield table. |

6.6.11.1. *PortD ConfigDefault*

| Bit | Bitfield Name | RW | Reset | Description |
|----------|------------------|----|-------|---|
| [31..30] | PortConnectivity | RW | 0 | Port connectivity: 0h = Port complex is connected to a jack; 1h = No physical connection for port; 2h = Fixed function device is attached; 3h = Both jack and internal device attached (info in all other fields refers to integrated device any presence detection refers to jack) |
| [29..24] | Location | RW | 1 | Location. Bits [5..4]: 0h = External on primary chassis; 1h = Internal; 2h = Separate chassis; 3h = Other. Bits [3..0]: 0h = N/A; 1h = Rear; 2h = Front; 3h = Left; 4h = Right; 5h = Top; 6h = Bottom; 7h-9h = Special; Ah-Fh = Reserved |
| [23..20] | Device | RW | 0 | Default device: 0h = Line out; 1h = Speaker; 2h = HP out; 3h = CD; 4h = SPDIF Out; 5h = Digital other out; 6h = Modem line side; 7h = Modem handset side; 8h = Line in; 9h = Aux; Ah = Mic in; Bh = Telephony; Ch = SPDIF In; Dh = Digital other in; Eh = Reserved; Fh = Other |

6.6.11.1. *PortD ConfigDefault*

| Bit | Bitfield Name | RW | Reset | Description |
|----------|----------------|----|-------|--|
| [19..16] | ConnectionType | RW | 1 | Connection type: 0h = Unknown; 1h = 1/8" stereo/mono; 2h = 1/4" stereo/mono; 3h = ATAPI internal; 4h = RCA; 5h = Optical; 6h = Other digital; 7h = Other analog; 8h = Multichannel analog (DIN); 9h = XLR/Professional; Ah = RJ-11 (modem); Bh = Combination; Ch-Eh = Reserved; Fh = Other |
| [15..12] | Color | RW | 4 | Color: 0h = Unknown; 1h = Black; 2h = Grey; 3h = Blue; 4h = Green; 5h = Red; 6h = Orange; 7h = Yellow; 8h = Purple; 9h = Pink; Ah-Dh = Reserved; Eh = White; Fh = Other |
| [11..8] | Misc | RW | 0 | Miscellaneous: Bits [3..1] = Reserved; Bit 0 = Jack detect override |
| [7..4] | Association | RW | 1 | Default association. |
| [3..0] | Sequence | RW | 0 | Sequence. |

6.7. **PortE Node (NID = 0E)**6.7.1. *PortE WCap*

| | Verb ID | Payload | Response |
|-----|---------|---------|---------------------|
| Get | F00 | 09 | See bitfield table. |

6.7.1.1. *PortE WCap*

| Bit | Bitfield Name | RW | Reset | Description |
|----------|---------------|----|-------|---|
| [31..24] | Rsvd2 | R | 00 | Reserved. |
| [23..20] | Type | R | 4 | Widget type: 0h = Out Converter; 1h = In Converter; 2h = Summing (Mixer); 3h = Selector (Mux); 4h = Pin Complex; 5h = Power; 6h = Volume Knob; 7h = Beep Generator; 8h-Eh = Reserved; Fh = Vendor Defined |

6.7.1.1. *PortE WCap*

| Bit | Bitfield Name | RW | Reset | Description |
|----------|---------------|----|-------|---|
| [19.:16] | Delay | R | 0 | Number of sample delays through widget. |
| [15.:12] | Rsvd1 | R | 0 | Reserved. |
| [11] | SwapCap | R | 0 | Left/right swap support: 1 = yes 0 = no. |
| [10] | PwrCntrl | R | 0 | Power state support: 1 = yes 0 = no. |
| [9] | Dig | R | 0 | Digital stream support: 1 = yes (digital) 0 = no (analog). |
| [8] | ConnList | R | 1 | Connection list present: 1 = yes 0 = no. |
| [7] | UnSolCap | R | 1 | Unsolicited response support: 1 = yes 0 = no. |
| [6] | ProcWidget | R | 0 | Processing state support: 1 = yes 0 = no. |
| [5] | Stripe | R | 0 | Striping support: 1 = yes 0 = no. |
| [4] | FormatOvrd | R | 0 | Stream format override: 1 = yes 0 = no. |
| [3] | AmpParOvrd | R | 0 | Amplifier capabilities override: 1 = yes no. |
| [2] | OutAmpPrsnt | R | 0 | Output amp present: 1 = yes 0 = no. |
| [1] | InAmpPrsnt | R | 1 | Input amp present: 1 = yes 0 = no. |
| [0] | Stereo | R | 1 | Stereo stream support: 1 = yes (stereo) 0 = no (mono). |

6.7.2. *PortE PinCap*

| | Verb ID | Payload | Response |
|-----|---------|---------|---------------------|
| Get | F00 | 0C | See bitfield table. |

6.7.2.1. *PortE PinCap*

| Bit | Bitfield Name | RW | Reset | Description |
|----------|---------------|----|-------|--|
| [31.:17] | Rsvd2 | R | 0000 | Reserved. |
| [16] | EapdCap | R | 0 | EAPD support: 1 = yes 0 = no. |
| [15.:8] | VrefCntrl | R | 17 | Vref support: bit 7 = Reserved; bit 6 = Reserved; bit 5 = 100% support (1 = yes 0 = no); bit 4 = 80% support (1 = yes 0 = no); bit 3 = Reserved; bit 2 = GND support (1 = yes 0 = no); bit 1 = 50% support (1 = yes 0 = no); bit 0 = Hi-Z support (1 = yes 0 = no) |
| [7] | Rsvd1 | R | 0 | Reserved. |
| [6] | BalancedIO | R | 0 | Balanced I/O support: 1 = yes 0 = no. |
| [5] | InCap | R | 1 | Input support: 1 = yes 0 = no. |
| [4] | OutCap | R | 1 | Output support: 1 = yes 0 = no. |
| [3] | HdphDrvCap | R | 0 | Headphone amp present: 1 = yes 0 = no. |
| [2] | PresDtctCap | R | 1 | Presence detection support: 1 = yes 0 = no. |
| [1] | TrigRqd | R | 1 | Trigger required for impedance sense: 1 = yes 0 = no. |
| [0] | ImpSenseCap | R | 0 | Impedance sense support: 1 = yes 0 = no. |

6.7.3. *PortE ConLst*

| | Verb ID | Payload | Response |
|-----|---------|---------|---------------------|
| Get | F00 | 0E | See bitfield table. |

6.7.3.1. *PortE ConLst*

| Bit | Bitfield Name | RW | Reset | Description |
|---------|---------------|----|--------|--|
| [31..8] | Rsvd | R | 000000 | Reserved. |
| [7] | LForm | R | 0 | Connection list format: 1 = long-form (15-bit) NID entries 0 = short-form (7-bit) NID entries. |
| [6..0] | ConL | R | 03 | Number of NID entries in connection list. |

6.7.4. *PortE ConLstEntry0*

| | Verb ID | Payload | Response |
|-----|---------|---------|---------------------|
| Get | F02 | 00 | See bitfield table. |

6.7.4.1. *PortE ConLstEntry0*

| Bit | Bitfield Name | RW | Reset | Description |
|----------|---------------|----|-------|--|
| [31..24] | ConL3 | R | 00 | Unused list entry. |
| [23..16] | ConL2 | R | 1E | MixerOutVol Summing widget (0x1E) |
| [15] | ConL1Range | R | 1 | 1 = ConL0..ConL1 defines a range of selectable inputs. |
| [15..8] | ConL1 | R | 17 | DAC2 Converter widget (0x17) |
| [7..0] | ConL0 | R | 15 | DAC0 Converter widget (0x15) |

6.7.5. *PortE ConSelectCtrl*

| | Verb ID | Payload | Response |
|-----|---------|---------|---------------------|
| Get | F01 | 00 | See bitfield table. |

6.7.5.1. *PortE ConSelectCtrl*

| Bit | Bitfield Name | RW | Reset | Description |
|---------|---------------|----|----------|----------------------------------|
| [31..2] | Rsvd | R | 00000000 | Reserved. |
| [1..0] | Index | RW | 0 | Connection select control index. |

6.7.6. *PortE PinWCntrl*

| | Verb ID | Payload | Response |
|-----|---------|---------|---------------------|
| Get | F07 | 00 | See bitfield table. |

6.7.6.1. *PortE PinWCntrl*

| Bit | Bitfield Name | RW | Reset | Description |
|---------|---------------|----|----------|--|
| [31..6] | Rsvd2 | R | 00000000 | Reserved. |
| [5] | InEn | RW | 0 | Input enable: 1 = enabled 0 = disabled. |
| [4..3] | Rsvd1 | R | 0 | Reserved. |
| [2..0] | VRefEn | RW | 0 | Vref selection (See VrefCntrl field of PinCap parameter for supported selections): 000b= HI-Z; 001b= 50%; 010b= GND; 011b= Reserved; 100b= 80%; 101b= 100%; 110b= Reserved; 111b= Reserved |

6.7.7. *PortE UnsolResp*

| | Verb ID | Payload | Response |
|-----|---------|---------|---------------------|
| Get | F08 | 00 | See bitfield table. |

6.7.7.1. *PortE UnsolResp*

| Bit | Bitfield Name | RW | Reset | Description |
|---------|---------------|----|--------|--|
| [31.:8] | Rsvd2 | R | 000000 | Reserved. |
| [7] | En | RW | 0 | Unsolicited response enable: 1 = enabled 0 = disabled. |
| [6] | Rsvd1 | R | 0 | Reserved. |
| [5.:0] | Tag | RW | 00 | Software programmable field returned in top six bits (31:26) of every Unsolicited Response generated by this node. |

6.7.8. *PortE ChSense*

| | Verb ID | Payload | Response |
|-----|---------|---------|---------------------|
| Get | F09 | 00 | See bitfield table. |

6.7.8.1. *PortD ChSense*

| Bit | Bitfield Name | RW | Reset | Description |
|---------|---------------|----|----------|---|
| [31] | PresDtct | R | 0 | Presence detection indicator: 1 = presence detected; 0 = presence not detected. |
| [30.:1] | Impedence | R | 3FFFFFFh | Impedance Sense Value (Bits 30:1): Measured impedance of the widget. An all ones value indicates an invalid sense reading |
| [0] | Execute | RW | 1 | Impedance Sense Value (Bit 0)/Trigger: Read = Impedance value bit 0 Write 0 = Impedance sense occurs using left channel Write 1 = Impedance sense occurs using right channel |

6.7.9. PortE InAmpLeft

| | Verb ID | Payload | Response |
|-----|---------|---------|---------------------|
| Get | B20 | 00 | See bitfield table. |

6.7.9.1. PortE InAmpLeft

| Bit | Bitfield Name | RW | Reset | Description |
|---------|---------------|----|--------|--|
| [31..2] | Rsvd1 | R | 000000 | Reserved. |
| [1..0] | Gain | RW | 0 | Amp gain step number (see InAmpCap parameter pertaining to this widget). |

6.7.10. PortE InAmpRight

| | Verb ID | Payload | Response |
|-----|---------|---------|---------------------|
| Get | B00 | 00 | See bitfield table. |

6.7.10.1. PortE InAmpRight

| Bit | Bitfield Name | RW | Reset | Description |
|---------|---------------|----|--------|--|
| [31..2] | Rsvd1 | R | 000000 | Reserved. |
| [1..0] | Gain | RW | 0 | Amp gain step number (see InAmpCap parameter pertaining to this widget). |

6.7.11. PortE ConfigDefault

| | Verb ID | Payload | Response |
|-----|---------|---------|---------------------|
| Get | F1C | 00 | See bitfield table. |

6.7.11.1. *PortE ConfigDefault*

| Bit | Bitfield Name | RW | Reset | Description |
|-----------|------------------|----|-------|--|
| [31..:30] | PortConnectivity | RW | 0 | Port connectivity: 0h = Port complex is connected to a jack; 1h = No physical connection for port; 2h = Fixed function device is attached; 3h = Both jack and internal device attached (info in all other fields refers to integrated device any presence detection refers to jack) |
| [29..:24] | Location | RW | 1 | Location. Bits [5..4]: 0h = External on primary chassis; 1h = Internal; 2h = Separate chassis; 3h = Other. Bits [3..0]: 0h = N/A; 1h = Rear; 2h = Front; 3h = Left; 4h = Right; 5h = Top; 6h = Bottom; 7h-9h = Special; Ah-Fh = Reserved |
| [23..:20] | Device | RW | A | Default device: 0h = Line out; 1h = Speaker; 2h = HP out; 3h = CD; 4h = SPDIF Out; 5h = Digital other out; 6h = Modem line side; 7h = Modem handset side; 8h = Line in; 9h = Aux; Ah = Mic in; Bh = Telephony; Ch = SPDIF In; Dh = Digital other in; Eh = Reserved; Fh = Other |
| [19..:16] | ConnectionType | RW | 1 | Connection type: 0h = Unknown; 1h = 1/8" stereo/mono; 2h = 1/4" stereo/mono; 3h = ATAPI internal; 4h = RCA; 5h = Optical; 6h = Other digital; 7h = Other analog; 8h = Multichannel analog (DIN); 9h = XLR/Professional; Ah = RJ-11 (modem); Bh = Combination; Ch-Eh = Reserved; Fh = Other |
| [15..:12] | Color | RW | 9 | Color: 0h = Unknown; 1h = Black; 2h = Grey; 3h = Blue; 4h = Green; 5h = Red; 6h = Orange; 7h = Yellow; 8h = Purple; 9h = Pink; Ah-Dh = Reserved; Eh = White; Fh = Other |
| [11..:8] | Misc | RW | 0 | Miscellaneous: Bits [3..1] = Reserved; Bit 0 = Jack detect override |
| [7..:4] | Association | RW | 2 | Default association. |
| [3..:0] | Sequence | RW | 0 | Sequence. |

6.8. PortF Node (NID = 0F)

6.8.1. PortF WCap

| | Verb ID | Payload | Response |
|-----|---------|---------|---------------------|
| Get | F00 | 09 | See bitfield table. |

6.8.1.1. PortF WCap

| Bit | Bitfield Name | RW | Reset | Description |
|----------|---------------|----|-------|---|
| [31.:24] | Rsvd2 | R | 00 | Reserved. |
| [23.:20] | Type | R | 4 | Widget type: 0h = Out Converter; 1h = In Converter; 2h = Summing (Mixer); 3h = Selector (Mux); 4h = Pin Complex; 5h = Power; 6h = Volume Knob; 7h = Beep Generator; 8h-Eh = Reserved; Fh = Vendor Defined |
| [19.:16] | Delay | R | 0 | Number of sample delays through widget. |
| [15.:12] | Rsvd1 | R | 0 | Reserved. |
| [11] | SwapCap | R | 0 | Left/right swap support: 1 = yes 0 = no. |
| [10] | PwrCntrl | R | 0 | Power state support: 1 = yes 0 = no. |
| [9] | Dig | R | 0 | Digital stream support: 1 = yes (digital) 0 = no (analog). |
| [8] | ConnList | R | 1 | Connection list present: 1 = yes 0 = no. |
| [7] | UnSolCap | R | 1 | Unsolicited response support: 1 = yes 0 = no. |
| [6] | ProcWidget | R | 0 | Processing state support: 1 = yes 0 = no. |
| [5] | Stripe | R | 0 | Striping support: 1 = yes 0 = no. |
| [4] | FormatOvrd | R | 0 | Stream format override: 1 = yes 0 = no. |
| [3] | AmpParOvrd | R | 0 | Amplifier capabilities override: 1 = yes no. |
| [2] | OutAmpPrsnt | R | 0 | Output amp present: 1 = yes 0 = no. |

6.8.1.1. *PortF WCap*

| Bit | Bitfield Name | RW | Reset | Description |
|-----|---------------|----|-------|---|
| [1] | InAmpPrsnt | R | 1 | Input amp present: 1 = yes 0 = no. |
| [0] | Stereo | R | 1 | Stereo stream support: 1 = yes (stereo) 0 = no (mono). |

6.8.2. *PortF PinCap*

| | Verb ID | Payload | Response |
|-----|---------|---------|---------------------|
| Get | F00 | 0C | See bitfield table. |

6.8.2.1. *PortF PinCap*

| Bit | Bitfield Name | RW | Reset | Description |
|----------|---------------|----|-------|--|
| [31.:17] | Rsvd2 | R | 0000 | Reserved. |
| [16] | EapdCap | R | 0 | EAPD support: 1 = yes 0 = no. |
| [15.:8] | VrefCntrl | R | 00 | Vref support: bit 7 = Reserved; bit 6 = Reserved; bit 5 = 100% support (1 = yes 0 = no); bit 4 = 80% support (1 = yes 0 = no); bit 3 = Reserved; bit 2 = GND support (1 = yes 0 = no); bit 1 = 50% support (1 = yes 0 = no); bit 0 = Hi-Z support (1 = yes 0 = no) |
| [7] | Rsvd1 | R | 0 | Reserved. |
| [6] | BalancedIO | R | 0 | Balanced I/O support: 1 = yes 0 = no. |
| [5] | InCap | R | 1 | Input support: 1 = yes 0 = no. |
| [4] | OutCap | R | 1 | Output support: 1 = yes 0 = no. |
| [3] | HdphDrvCap | R | 0 | Headphone amp present: 1 = yes 0 = no. |
| [2] | PresDtctCap | R | 1 | Presence detection support: 1 = yes 0 = no. |

6.8.2.1. *PortF PinCap*

| Bit | Bitfield Name | RW | Reset | Description |
|-----|---------------|----|-------|--|
| [1] | TrigRqd | R | 1 | Trigger required for impedance sense: 1 = yes 0 = no. |
| [0] | ImpSenseCap | R | 1 | Impedance sense support: 1 = yes 0 = no. |

6.8.3. *PortF ConLst*

| | Verb ID | Payload | Response |
|-----|---------|---------|---------------------|
| Get | F00 | 0E | See bitfield table. |

6.8.3.1. *PortF ConLst*

| Bit | Bitfield Name | RW | Reset | Description |
|---------|---------------|----|--------|--|
| [31..8] | Rsvd | R | 000000 | Reserved. |
| [7] | LForm | R | 0 | Connection list format: 1 = long-form (15-bit) NID entries 0 = short-form (7-bit) NID entries. |
| [6..0] | ConL | R | 03 | Number of NID entries in connection list. |

6.8.4. *PortF ConLstEntry0*

| | Verb ID | Payload | Response |
|-----|---------|---------|---------------------|
| Get | F02 | 00 | See bitfield table. |

6.8.4.1. *PortF ConLstEntry0*

| Bit | Bitfield Name | RW | Reset | Description |
|----------|---------------|----|-------|--|
| [31.:24] | ConL3 | R | 00 | Unused list entry. |
| [23.:16] | ConL2 | R | 17 | InputMixer Summing widget (0x17) |
| [15] | ConL1Range | R | 1 | 1 = ConL0..ConL1 defines a range of selectable inputs. |
| [14.:8] | ConL1 | R | 11 | DAC1 Converter widget (0x11) |
| [7.:0] | ConL0 | R | 10 | DAC0 Converter widget (0x10) |

6.8.5. *PortF ConSelectCtrl*

| | Verb ID | Payload | Response |
|-----|---------|---------|---------------------|
| Get | F01 | 00 | See bitfield table. |

6.8.5.1. *PortF ConSelectCtrl*

| Bit | Bitfield Name | RW | Reset | Description |
|---------|---------------|----|----------|----------------------------------|
| [31.:2] | Rsvd | R | 00000000 | Reserved. |
| [1.:0] | Index | RW | 0 | Connection select control index. |

6.8.6. *PortF PinWCntrl*

| | Verb ID | Payload | Response |
|-----|---------|---------|---------------------|
| Get | F07 | 00 | See bitfield table. |

6.8.6.1. *PortF PinWCntrl*

| Bit | Bitfield Name | RW | Reset | Description |
|---------|---------------|----|--------|---|
| [31.:7] | Rsvd2 | R | 000000 | Reserved. |
| [6] | OutEn | RW | 0 | Output enable: 1 = enabled 0 = disabled. |
| [5] | InEn | RW | 0 | input enable: 1 = enabled 0 = disabled. |
| [4.:0] | Rsvd1 | R | 0 | Reserved. |

6.8.7. *PortF UnsolicitedResp*

| | Verb ID | Payload | Response |
|-----|---------|---------|---------------------|
| Get | F08 | 00 | See bitfield table. |

6.8.7.1. *PortF UnsolicitedResp*

| Bit | Bitfield Name | RW | Reset | Description |
|---------|---------------|----|--------|--|
| [31.:8] | Rsvd2 | R | 000000 | Reserved. |
| [7] | En | RW | 0 | Unsolicited response enable: 1 = enabled 0 = disabled. |
| [6] | Rsvd1 | R | 0 | Reserved. |
| [5.:0] | Tag | RW | 00 | Software programmable field returned in top six bits (31:26) of every Unsolicited Response generated by this node. |

6.8.8. *PortF ChSense*

| | Verb ID | Payload | Response |
|-----|---------|---------|---------------------|
| Get | F09 | 00 | See bitfield table. |

6.8.8.1. *PortF ChSense*

| Bit | Bitfield Name | RW | Reset | Description |
|---------|---------------|----|-----------|---|
| [31] | PresDtct | R | 0 | Presence detection indicator: 1 = presence detected; 0 = presence not detected. |
| [30.:1] | Impedance | R | 3FFFFFFFh | Impedance Sense Value (Bits 30:1): Measured impedance of the widget. An all ones value indicates an invalid sense reading |
| [0] | Execute | RW | 1 | Impedance Sense Value (Bit 0)/Trigger: Read = Impedance value bit 0 Write 0 = Impedance sense occurs using left channel Write 1 = Impedance sense occurs using right channel |

6.8.9. *PortF InAmpLeft*

| | Verb ID | Payload | Response |
|-----|---------|---------|---------------------|
| Get | B20 | 00 | See bitfield table. |

6.8.9.1. *PortF InAmpLeft*

| Bit | Bitfield Name | RW | Reset | Description |
|---------|---------------|----|--------|--|
| [31.:2] | Rsvd1 | R | 000000 | Reserved. |
| [1.:0] | Gain | RW | 0 | Amp gain step number (see InAmpCap parameter pertaining to this widget). |

6.8.10. *PortF InAmpRight*

| | Verb ID | Payload | Response |
|-----|---------|---------|---------------------|
| Get | B00 | 00 | See bitfield table. |

6.8.10.1. *PortF InAmpRight*

| Bit | Bitfield Name | RW | Reset | Description |
|---------|---------------|----|--------|--|
| [31..2] | Rsvd1 | R | 000000 | Reserved. |
| [1..0] | Gain | RW | 0 | Amp gain step number (see InAmpCap parameter pertaining to this widget). |

6.9. PortG Node (NID = 10)

6.9.1. *PortG WCap*

| | Verb ID | Payload | Response |
|-----|---------|---------|---------------------|
| Get | F00 | 09 | See bitfield table. |

6.9.1.1. *PortG WCap*

| Bit | Bitfield Name | RW | Reset | Description |
|----------|---------------|----|-------|---|
| [31..24] | Rsvd2 | R | 00 | Reserved. |
| [23..20] | Type | R | 4 | Widget type: 0h = Out Converter; 1h = In Converter; 2h = Summing (Mixer); 3h = Selector (Mux); 4h = Pin Complex; 5h = Power; 6h = Volume Knob; 7h = Beep Generator; 8h-Eh = Reserved; Fh = Vendor Defined |
| [19..16] | Delay | R | 0 | Number of sample delays through widget. |
| [15..12] | Rsvd1 | R | 0 | Reserved. |
| [11] | SwapCap | R | 0 | Left/right swap support: 1 = yes 0 = no. |
| [10] | PwrCntrl | R | 0 | Power state support: 1 = yes 0 = no. |
| [9] | Dig | R | 0 | Digital stream support: 1 = yes (digital) 0 = no (analog). |
| [8] | ConnList | R | 1 | Connection list present: 1 = yes 0 = no. |

6.9.1.1. *PortG WCap*

| Bit | Bitfield Name | RW | Reset | Description |
|-----|---------------|----|-------|---|
| [7] | UnSolCap | R | 1 | Unsolicited response support: 1 = yes 0 = no. |
| [6] | ProcWidget | R | 0 | Processing state support: 1 = yes 0 = no. |
| [5] | Stripe | R | 0 | Striping support: 1 = yes 0 = no. |
| [4] | FormatOvrd | R | 0 | Stream format override: 1 = yes 0 = no. |
| [3] | AmpParOvrd | R | 0 | Amplifier capabilities override: 1 = yes no. |
| [2] | OutAmpPrsnt | R | 0 | Output amp present: 1 = yes 0 = no. |
| [1] | InAmpPrsnt | R | 1 | Input amp present: 1 = yes 0 = no. |
| [0] | Stereo | R | 1 | Stereo stream support: 1 = yes (stereo) 0 = no (mono). |

6.9.2. *PortG PinCap*

| | Verb ID | Payload | Response |
|-----|---------|---------|---------------------|
| Get | F00 | 0C | See bitfield table. |

6.9.2.1. *PortG PinCap*

| Bit | Bitfield Name | RW | Reset | Description |
|----------|---------------|----|-------|--|
| [31.:17] | Rsvd2 | R | 0000 | Reserved. |
| [16] | EapdCap | R | 0 | EAPD support: 1 = yes 0 = no. |
| [15.:8] | VrefCntrl | R | 00 | Vref support: bit 7 = Reserved; bit 6 = Reserved; bit 5 = 100% support (1 = yes 0 = no); bit 4 = 80% support (1 = yes 0 = no); bit 3 = Reserved; bit 2 = GND support (1 = yes 0 = no); bit 1 = 50% support (1 = yes 0 = no); bit 0 = Hi-Z support (1 = yes 0 = no) |
| [7] | Rsvd1 | R | 0 | Reserved. |

6.9.2.1. *PortG PinCap*

| Bit | Bitfield Name | RW | Reset | Description |
|-----|---------------|----|-------|--|
| [6] | BalancedIO | R | 0 | Balanced I/O support: 1 = yes 0 = no. |
| [5] | InCap | R | 1 | Input support: 1 = yes 0 = no. |
| [4] | OutCap | R | 1 | Output support: 1 = yes 0 = no. |
| [3] | HdphDrvCap | R | 0 | Headphone amp present: 1 = yes 0 = no. |
| [2] | PresDtctCap | R | 1 | Presence detection support: 1 = yes 0 = no. |
| [1] | TrigRqd | R | 1 | Trigger required for impedance sense: 1 = yes 0 = no. |
| [0] | ImpSenseCap | R | 1 | Impedance sense support: 1 = yes 0 = no. |

6.9.3. *PortG ConLst*

| | Verb ID | Payload | Response |
|-----|---------|---------|---------------------|
| Get | F00 | 0E | See bitfield table. |

6.9.3.1. *PortG ConLst*

| Bit | Bitfield Name | RW | Reset | Description |
|---------|---------------|----|--------|--|
| [31..8] | Rsvd | R | 000000 | Reserved. |
| [7] | LForm | R | 0 | Connection list format: 1 = long-form (15-bit) NID entries 0 = short-form (7-bit) NID entries. |
| [6..0] | ConL | R | 03 | Number of NID entries in connection list. |

6.9.4. PortG ConLstEntry0

| | Verb ID | Payload | Response |
|-----|---------|---------|---------------------|
| Get | F02 | 00 | See bitfield table. |

6.9.4.1. PortG ConLstEntry0

| Bit | Bitfield Name | RW | Reset | Description |
|----------|---------------|----|-------|--|
| [31..24] | ConL3 | R | 00 | Unused list entry. |
| [23..16] | ConL2 | R | 1E | MixerOutVol Selector widget (0x1E) |
| [15] | ConL1Range | R | 1 | 1 = ConL0..ConL1 defines a range of selectable inputs. |
| [14..8] | ConL1 | R | 17 | DAC2 Converter widget (0x17) |
| [7..0] | ConL0 | R | 15 | DAC0 Converter widget (0x15) |

6.9.5. PortG ConSelectCtrl

| | Verb ID | Payload | Response |
|-----|---------|---------|---------------------|
| Get | F01 | 00 | See bitfield table. |

6.9.5.1. PortG ConSelectCtrl

| Bit | Bitfield Name | RW | Reset | Description |
|---------|---------------|----|----------|----------------------------------|
| [31..2] | Rsvd | R | 00000000 | Reserved. |
| [1..0] | Index | RW | 0 | Connection select control index. |

6.9.6. PortG PinWCntrl

| | Verb ID | Payload | Response |
|-----|---------|---------|---------------------|
| Get | F07 | 00 | See bitfield table. |

6.9.6.1. PortG PinWCntrl

| Bit | Bitfield Name | RW | Reset | Description |
|---------|---------------|----|--------|---|
| [31.:7] | Rsvd2 | R | 000000 | Reserved. |
| [6] | OutEn | RW | 0 | Output enable: 1 = enabled 0 = disabled. |
| [5] | InEn | RW | 0 | input enable: 1 = enabled 0 = disabled. |
| [4.:0] | Rsvd1 | R | 0 | Reserved. |

6.9.7. PortG UnsolResp

| | Verb ID | Payload | Response |
|-----|---------|---------|---------------------|
| Get | F08 | 00 | See bitfield table. |

6.9.7.1. PortG UnsolResp

| Bit | Bitfield Name | RW | Reset | Description |
|---------|---------------|----|--------|--|
| [31.:8] | Rsvd2 | R | 000000 | Reserved. |
| [7] | En | RW | 0 | Unsolicited response enable: 1 = enabled 0 = disabled. |
| [6] | Rsvd1 | R | 0 | Reserved. |
| [5.:0] | Tag | RW | 00 | Software programmable field returned in top six bits (31:26) of every Unsolicited Response generated by this node. |

6.9.8. PortG ChSense

| | Verb ID | Payload | Response |
|-----|---------|---------|---------------------|
| Get | F09 | 00 | See bitfield table. |

6.9.8.1. PortG ChSense

| Bit | Bitfield Name | RW | Reset | Description |
|---------|---------------|----|----------|---|
| [31] | PresDtct | R | 0 | Presence detection indicator: 1 = presence detected; 0 = presence not detected. |
| [30.:1] | Impedence | R | 3FFFFFFh | Impedance Sense Value (Bits 30:1): Measured impedance of the widget. An all ones value indicates an invalid sense reading |
| [0] | Execute | RW | 1 | Impedance Sense Value (Bit 0)/Trigger: Read = Impedance value bit 0 Write 0 = Impedance sense occurs using left channel Write 1 = Impedance sense occurs using right channel |

6.9.9. PortG InAmpLeft

| | Verb ID | Payload | Response |
|-----|---------|---------|---------------------|
| Get | B20 | 00 | See bitfield table. |

6.9.9.1. PortG InAmpLeft

| Bit | Bitfield Name | RW | Reset | Description |
|---------|---------------|----|--------|--|
| [31.:2] | Rsvd1 | R | 000000 | Reserved. |
| [1.:0] | Gain | RW | 0 | Amp gain step number (see InAmpCap parameter pertaining to this widget). |

6.9.10. PortG InAmpRight

| | Verb ID | Payload | Response |
|-----|---------|---------|---------------------|
| Get | B00 | 00 | See bitfield table. |

6.9.10.1. PortG InAmpRight

| Bit | Bitfield Name | RW | Reset | Description |
|---------|---------------|----|--------|--|
| [31..2] | Rsvd1 | R | 000000 | Reserved. |
| [1..0] | Gain | RW | 0 | Amp gain step number (see InAmpCap parameter pertaining to this widget). |

6.9.11. PortG ConfigDefault

| | Verb ID | Payload | Response |
|-----|---------|---------|---------------------|
| Get | F1C | 00 | See bitfield table. |

6.9.11.1. PortG ConfigDefault

| Bit | Bitfield Name | RW | Reset | Description |
|----------|------------------|----|-------|--|
| [31..30] | PortConnectivity | RW | 0 | Port connectivity: 0h = Port complex is connected to a jack; 1h = No physical connection for port; 2h = Fixed function device is attached; 3h = Both jack and internal device attached (info in all other fields refers to integrated device any presence detection refers to jack) |
| [29..24] | Location | RW | 01 | Location. Bits [5..4]: 0h = External on primary chassis; 1h = Internal; 2h = Separate chassis; 3h = Other. Bits [3..0]: 0h = N/A; 1h = Rear; 2h = Front; 3h = Left; 4h = Right; 5h = Top; 6h = Bottom; 7h-9h = Special; Ah-Fh = Reserved |
| [23..20] | Device | RW | 0 | Default device: 0h = Line out; 1h = Speaker; 2h = HP out; 3h = CD; 4h = SPDIF Out; 5h = Digital other out; 6h = Modem line side; 7h = Modem handset side; 8h = Line in; 9h = Aux; Ah = Mic in; Bh = Telephony; Ch = SPDIF In; Dh = Digital other in; Eh = Reserved; Fh = Other |
| [19..16] | ConnectionType | RW | 1 | Connection type: 0h = Unknown; 1h = 1/8" stereo/mono; 2h = 1/4" stereo/mono; 3h = ATAPI internal; 4h = RCA; 5h = Optical; 6h = Other digital; 7h = Other analog; 8h = Multichannel analog (DIN); 9h = XLR/Professional; Ah = RJ-11 (modem); Bh = Combination; Ch-Eh = Reserved; Fh = Other |
| [15..12] | Color | RW | 6 | Color: 0h = Unknown; 1h = Black; 2h = Grey; 3h = Blue; 4h = Green; 5h = Red; 6h = Orange; 7h = Yellow; 8h = Purple; 9h = Pink; Ah-Dh = Reserved; Eh = White; Fh = Other |

6.9.11.1. *PortG ConfigDefault*

| Bit | Bitfield Name | RW | Reset | Description |
|---------|---------------|----|-------|---|
| [11..8] | Misc | RW | 0 | Miscellaneous: Bits [3..1] = Reserved; Bit 0 = Jack detect override |
| [7..4] | Association | RW | 1 | Default association. |
| [3..0] | Sequence | RW | 1 | Sequence. |

6.10. **PortH Node (NID = 11)**6.10.1. *PortH WCap*

| | Verb ID | Payload | Response |
|-----|---------|---------|---------------------|
| Get | F00 | 09 | See bitfield table. |

6.10.1.1. *PortH WCap*

| Bit | Bitfield Name | RW | Reset | Description |
|----------|---------------|----|-------|---|
| [31..24] | Rsvd2 | R | 00 | Reserved. |
| [23..20] | Type | R | 4 | Widget type: 0h = Out Converter; 1h = In Converter; 2h = Summing (Mixer); 3h = Selector (Mux); 4h = Pin Complex; 5h = Power; 6h = Volume Knob; 7h = Beep Generator; 8h-Eh = Reserved; Fh = Vendor Defined |
| [19..16] | Delay | R | 0 | Number of sample delays through widget. |
| [15..12] | Rsvd1 | R | 0 | Reserved. |
| [11] | SwapCap | R | 0 | Left/right swap support: 1 = yes 0 = no. |
| [10] | PwrCntrl | R | 0 | Power state support: 1 = yes 0 = no. |
| [9] | Dig | R | 0 | Digital stream support: 1 = yes (digital) 0 = no (analog). |
| [8] | ConnList | R | 1 | Connection list present: 1 = yes 0 = no. |

6.10.1.1. *Porth WCap*

| Bit | Bitfield Name | RW | Reset | Description |
|-----|---------------|----|-------|---|
| [7] | UnSolCap | R | 1 | Unsolicited response support: 1 = yes 0 = no. |
| [6] | ProcWidget | R | 0 | Processing state support: 1 = yes 0 = no. |
| [5] | Stripe | R | 0 | Striping support: 1 = yes 0 = no. |
| [4] | FormatOvrd | R | 0 | Stream format override: 1 = yes 0 = no. |
| [3] | AmpParOvrd | R | 0 | Amplifier capabilities override: 1 = yes no. |
| [2] | OutAmpPrsnt | R | 0 | Output amp present: 1 = yes 0 = no. |
| [1] | InAmpPrsnt | R | 1 | Input amp present: 1 = yes 0 = no. |
| [0] | Stereo | R | 1 | Stereo stream support: 1 = yes (stereo) 0 = no (mono). |

6.10.2. *Porth PinCap*

| | Verb ID | Payload | Response |
|-----|---------|---------|---------------------|
| Get | F00 | 0C | See bitfield table. |

6.10.2.1. *Porth PinCap*

| Bit | Bitfield Name | RW | Reset | Description |
|----------|---------------|----|-------|--|
| [31.:17] | Rsvd2 | R | 0000 | Reserved. |
| [16] | EapdCap | R | 0 | EAPD support: 1 = yes 0 = no. |
| [15.:8] | VrefCntrl | R | 00 | Vref support: bit 7 = Reserved; bit 6 = Reserved; bit 5 = 100% support (1 = yes 0 = no); bit 4 = 80% support (1 = yes 0 = no); bit 3 = Reserved; bit 2 = GND support (1 = yes 0 = no); bit 1 = 50% support (1 = yes 0 = no); bit 0 = Hi-Z support (1 = yes 0 = no) |
| [7] | Rsvd1 | R | 0 | Reserved. |

6.10.2.1. *Porth PinCap*

| Bit | Bitfield Name | RW | Reset | Description |
|-----|---------------|----|-------|--|
| [6] | BalancedIO | R | 0 | Balanced I/O support: 1 = yes 0 = no. |
| [5] | InCap | R | 1 | Input support: 1 = yes 0 = no. |
| [4] | OutCap | R | 1 | Output support: 1 = yes 0 = no. |
| [3] | HdphDrvCap | R | 0 | Headphone amp present: 1 = yes 0 = no. |
| [2] | PresDtctCap | R | 1 | Presence detection support: 1 = yes 0 = no. |
| [1] | TrigRqd | R | 1 | Trigger required for impedance sense: 1 = yes 0 = no. |
| [0] | ImpSenseCap | R | 1 | Impedance sense support: 1 = yes 0 = no. |

6.10.3. *Porth ConLst*

| | Verb ID | Payload | Response |
|-----|---------|---------|---------------------|
| Get | F00 | 0E | See bitfield table. |

6.10.3.1. *Porth ConLst*

| Bit | Bitfield Name | RW | Reset | Description |
|---------|---------------|----|--------|--|
| [31..8] | Rsvd | R | 000000 | Reserved. |
| [7] | LForm | R | 0 | Connection list format: 1 = long-form (15-bit) NID entries 0 = short-form (7-bit) NID entries. |
| [6..0] | ConL | R | 03 | Number of NID entries in connection list. |

6.10.4. Porth ConLstEntry0

| | Verb ID | Payload | Response |
|-----|---------|---------|---------------------|
| Get | F02 | 00 | See bitfield table. |

6.10.4.1. Porth ConLstEntry0

| Bit | Bitfield Name | RW | Reset | Description |
|----------|---------------|----|-------|--|
| [31..24] | ConL3 | R | 00 | Unused list entry. |
| [23..16] | ConL2 | R | 1Eh | MixerOutVol Selector widget (0x1E) |
| [15] | ConL1Range | R | 1 | 1 = ConL0..ConL1 defines a range of selectable inputs. |
| [14..8] | ConL1 | R | 17 | DAC2 Converter widget (0x17) |
| [7..0] | ConL0 | R | 15 | DAC0 Converter widget (0x15) |

6.10.5. Porth ConSelectCtrl

| | Verb ID | Payload | Response |
|-----|---------|---------|---------------------|
| Get | F01 | 00 | See bitfield table. |

6.10.5.1. Porth ConSelectCtrl

| Bit | Bitfield Name | RW | Reset | Description |
|---------|---------------|----|----------|----------------------------------|
| [31..2] | Rsvd | R | 00000000 | Reserved. |
| [1..0] | Index | RW | 0 | Connection select control index. |

6.10.6. Porth PinWCntrl

| | Verb ID | Payload | Response |
|-----|---------|---------|---------------------|
| Get | F07 | 00 | See bitfield table. |

6.10.6.1. Porth PinWCntrl

| Bit | Bitfield Name | RW | Reset | Description |
|---------|---------------|----|--------|---|
| [31..7] | Rsvd2 | R | 000000 | Reserved. |
| [6] | OutEn | RW | 0 | Output enable: 1 = enabled 0 = disabled. |
| [5] | InEn | RW | 0 | input enable: 1 = enabled 0 = disabled. |
| [4..0] | Rsvd1 | R | 0 | Reserved. |

6.10.7. Porth UnsolicitedResp

| | Verb ID | Payload | Response |
|-----|---------|---------|---------------------|
| Get | F08 | 00 | See bitfield table. |

6.10.7.1. Porth UnsolicitedResp

| Bit | Bitfield Name | RW | Reset | Description |
|---------|---------------|----|--------|--|
| [31..8] | Rsvd2 | R | 000000 | Reserved. |
| [7] | En | RW | 0 | Unsolicited response enable: 1 = enabled 0 = disabled. |
| [6] | Rsvd1 | R | 0 | Reserved. |
| [5..0] | Tag | RW | 00 | Software programmable field returned in top six bits (31:26) of every Unsolicited Response generated by this node. |

6.10.8. Porth ChSense

| | Verb ID | Payload | Response |
|-----|---------|---------|---------------------|
| Get | F09 | 00 | See bitfield table. |

6.10.8.1. Porth ChSense

| Bit | Bitfield Name | RW | Reset | Description |
|---------|---------------|----|----------|---|
| [31] | PresDtct | R | 0 | Presence detection indicator: 1 = presence detected; 0 = presence not detected. |
| [30.:1] | Impedence | R | 3FFFFFFh | Impedance Sense Value (Bits 30:1): Measured impedance of the widget. An all ones value indicates an invalid sense reading |
| [0] | Execute | RW | 1 | Impedance Sense Value (Bit 0)/Trigger: Read = Impedance value bit 0 Write 0 = Impedance sense occurs using left channel Write 1 = Impedance sense occurs using right channel |

6.10.9. Porth InAmpLeft

| | Verb ID | Payload | Response |
|-----|---------|---------|---------------------|
| Get | B20 | 00 | See bitfield table. |

6.10.9.1. Porth InAmpLeft

| Bit | Bitfield Name | RW | Reset | Description |
|---------|---------------|----|--------|--|
| [31.:2] | Rsvd1 | R | 000000 | Reserved. |
| [1.:0] | Gain | RW | 0 | Amp gain step number (see InAmpCap parameter pertaining to this widget). |

6.10.10. Porth InAmpRight

| | Verb ID | Payload | Response |
|-----|---------|---------|---------------------|
| Get | B00 | 00 | See bitfield table. |

6.10.10.1. Porth InAmpRight

| Bit | Bitfield Name | RW | Reset | Description |
|---------|---------------|----|--------|--|
| [31..2] | Rsvd1 | R | 000000 | Reserved. |
| [1..0] | Gain | RW | 0 | Amp gain step number (see InAmpCap parameter pertaining to this widget). |

6.10.11. Porth ConfigDefault

| | Verb ID | Payload | Response |
|-----|---------|---------|---------------------|
| Get | F1C | 00 | See bitfield table. |

6.10.11.1. Porth ConfigDefault

| Bit | Bitfield Name | RW | Reset | Description |
|-----------|------------------|----|-------|--|
| [31..:30] | PortConnectivity | RW | 0 | Port connectivity: 0h = Port complex is connected to a jack; 1h = No physical connection for port; 2h = Fixed function device is attached; 3h = Both jack and internal device attached (info in all other fields refers to integrated device any presence detection refers to jack) |
| [29..:24] | Location | RW | 01 | Location. Bits [5..4]: 0h = External on primary chassis; 1h = Internal; 2h = Separate chassis; 3h = Other. Bits [3..0]: 0h = N/A; 1h = Rear; 2h = Front; 3h = Left; 4h = Right; 5h = Top; 6h = Bottom; 7h-9h = Special; Ah-Fh = Reserved |
| [23..:20] | Device | RW | 0 | Default device: 0h = Line out; 1h = Speaker; 2h = HP out; 3h = CD; 4h = SPDIF Out; 5h = Digital other out; 6h = Modem line side; 7h = Modem handset side; 8h = Line in; 9h = Aux; Ah = Mic in; Bh = Telephony; Ch = SPDIF In; Dh = Digital other in; Eh = Reserved; Fh = Other |
| [19..:16] | ConnectionType | RW | 1 | Connection type: 0h = Unknown; 1h = 1/8" stereo/mono; 2h = 1/4" stereo/mono; 3h = ATAPI internal; 4h = RCA; 5h = Optical; 6h = Other digital; 7h = Other analog; 8h = Multichannel analog (DIN); 9h = XLR/Professional; Ah = RJ-11 (modem); Bh = Combination; Ch-Eh = Reserved; Fh = Other |
| [15..:12] | Color | RW | 2 | Color: 0h = Unknown; 1h = Black; 2h = Grey; 3h = Blue; 4h = Green; 5h = Red; 6h = Orange; 7h = Yellow; 8h = Purple; 9h = Pink; Ah-Dh = Reserved; Eh = White; Fh = Other |

6.10.11.1. *PortH ConfigDefault*

| Bit | Bitfield Name | RW | Reset | Description |
|---------|---------------|----|-------|---|
| [11..8] | Misc | RW | 0 | Miscellaneous: Bits [3..1] = Reserved; Bit 0 = Jack detect override |
| [7..4] | Association | RW | 1 | Default association. |
| [3..0] | Sequence | RW | 4 | Sequence. |

6.11. PortI Node (NID = 12)

6.11.1. *PortI WCap*

| | Verb ID | Payload | Response |
|-----|---------|---------|---------------------|
| Get | F00 | 09 | See bitfield table. |

6.11.1.1. *PortI WCap*

| Bit | Bitfield Name | RW | Reset | Description |
|----------|---------------|----|-------|---|
| [31..24] | Rsvd2 | R | 00 | Reserved. |
| [23..20] | Type | R | 4 | Widget type: 0h = Out Converter; 1h = In Converter; 2h = Summing (Mixer); 3h = Selector (Mux); 4h = Pin Complex; 5h = Power; 6h = Volume Knob; 7h = Beep Generator; 8h-Eh = Reserved; Fh = Vendor Defined |
| [19..16] | Delay | R | 0 | Number of sample delays through widget. |
| [15..12] | Rsvd1 | R | 0 | Reserved. |
| [11] | SwapCap | R | 0 | Left/right swap support: 1 = yes 0 = no. |
| [10] | PwrCntrl | R | 0 | Power state support: 1 = yes 0 = no. |
| [9] | Dig | R | 0 | Digital stream support: 1 = yes (digital) 0 = no (analog). |
| [8] | ConnList | R | 0 | Connection list present: 1 = yes 0 = no. |

6.11.1.1. *Port1 WCap*

| Bit | Bitfield Name | RW | Reset | Description |
|-----|---------------|----|-------|---|
| [7] | UnSolCap | R | 1 | Unsolicited response support: 1 = yes 0 = no. |
| [6] | ProcWidget | R | 0 | Processing state support: 1 = yes 0 = no. |
| [5] | Stripe | R | 0 | Striping support: 1 = yes 0 = no. |
| [4] | FormatOvrd | R | 0 | Stream format override: 1 = yes 0 = no. |
| [3] | AmpParOvrd | R | 0 | Amplifier capabilities override: 1 = yes no. |
| [2] | OutAmpPrsnt | R | 0 | Output amp present: 1 = yes 0 = no. |
| [1] | InAmpPrsnt | R | 0 | Input amp present: 1 = yes 0 = no. |
| [0] | Stereo | R | 1 | Stereo stream support: 1 = yes (stereo) 0 = no (mono). |

6.11.2. *Port1 PinCap*

| | Verb ID | Payload | Response |
|-----|---------|---------|---------------------|
| Get | F00 | 0C | See bitfield table. |

6.11.2.1. *Port1 PinCap*

| Bit | Bitfield Name | RW | Reset | Description |
|----------|---------------|----|-------|--|
| [31.:17] | Rsvd2 | R | 0000 | Reserved. |
| [16] | EapdCap | R | 0 | EAPD support: 1 = yes 0 = no. |
| [15.:8] | VrefCntrl | R | 00 | Vref support: bit 7 = Reserved; bit 6 = Reserved; bit 5 = 100% support (1 = yes 0 = no); bit 4 = 80% support (1 = yes 0 = no); bit 3 = Reserved; bit 2 = GND support (1 = yes 0 = no); bit 1 = 50% support (1 = yes 0 = no); bit 0 = Hi-Z support (1 = yes 0 = no) |
| [7] | Rsvd1 | R | 0 | Reserved. |

6.11.2.1. *PortI PinCap*

| Bit | Bitfield Name | RW | Reset | Description |
|-----|---------------|----|-------|--|
| [6] | BalancedIO | R | 0 | Balanced I/O support: 1 = yes 0 = no. |
| [5] | InCap | R | 1 | Input support: 1 = yes 0 = no. |
| [4] | OutCap | R | 1 | Output support: 1 = yes 0 = no. |
| [3] | HdphDrvCap | R | 0 | Headphone amp present: 1 = yes 0 = no. |
| [2] | PresDtctCap | R | 1 | Presence detection support: 1 = yes 0 = no. |
| [1] | TrigRqd | R | 1 | Trigger required for impedance sense: 1 = yes 0 = no. |
| [0] | ImpSenseCap | R | 1 | Impedance sense support: 1 = yes 0 = no. |

6.11.3. *PortI PinWCntrl*

| | Verb ID | Payload | Response |
|-----|---------|---------|---------------------|
| Get | F07 | 00 | See bitfield table. |

6.11.3.1. *PortI PinWCntrl*

| Bit | Bitfield Name | RW | Reset | Description |
|---------|---------------|----|--------|---|
| [31..6] | Rsvd2 | R | 000000 | Reserved. |
| [5] | InEn | RW | 0 | input enable: 1 = enabled 0 = disabled. |
| [4..0] | Rsvd1 | R | 0 | Reserved. |

6.11.4. *PortI UnsolResp*

| | Verb ID | Payload | Response |
|-----|---------|---------|---------------------|
| Get | F08 | 00 | See bitfield table. |

6.11.4.1. *PortI UnsolResp*

| Bit | Bitfield Name | RW | Reset | Description |
|---------|---------------|----|--------|--|
| [31..8] | Rsvd2 | R | 000000 | Reserved. |
| [7] | En | RW | 0 | Unsolicited response enable: 1 = enabled 0 = disabled. |
| [6] | Rsvd1 | R | 0 | Reserved. |
| [5..0] | Tag | RW | 00 | Software programmable field returned in top six bits (31:26) of every Unsolicited Response generated by this node. |

6.11.5. *PortI ChSense*

| | Verb ID | Payload | Response |
|-----|---------|---------|---------------------|
| Get | F09 | 00 | See bitfield table. |

6.11.5.1. *PortI ChSense*

| Bit | Bitfield Name | RW | Reset | Description |
|---------|---------------|----|----------|---|
| [31] | PresDtct | R | 0 | Presence detection indicator: 1 = presence detected; 0 = presence not detected. |
| [30..0] | Rsvd | R | 00000000 | Reserved |

6.11.6. *PortI ConfigDefault*

| | Verb ID | Payload | Response |
|-----|---------|---------|---------------------|
| Get | F1C | 00 | See bitfield table. |

6.11.6.1. *PortH ConfigDefault*

| Bit | Bitfield Name | RW | Reset | Description |
|----------|------------------|----|-------|--|
| [31..30] | PortConnectivity | RW | 2 | Port connectivity: 0h = Port complex is connected to a jack; 1h = No physical connection for port; 2h = Fixed function device is attached; 3h = Both jack and internal device attached (info in all other fields refers to integrated device any presence detection refers to jack) |
| [29..24] | Location | RW | 19 | Location. Bits [5..4]: 0h = External on primary chassis; 1h = Internal; 2h = Separate chassis; 3h = Other. Bits [3..0]: 0h = N/A; 1h = Rear; 2h = Front; 3h = Left; 4h = Right; 5h = Top; 6h = Bottom; 7h-9h = Special; Ah-Fh = Reserved |
| [23..20] | Device | RW | 3 | Default device: 0h = Line out; 1h = Speaker; 2h = HP out; 3h = CD; 4h = SPDIF Out; 5h = Digital other out; 6h = Modem line side; 7h = Modem handset side; 8h = Line in; 9h = Aux; Ah = Mic in; Bh = Telephony; Ch = SPDIF In; Dh = Digital other in; Eh = Reserved; Fh = Other |
| [19..16] | ConnectionType | RW | 3 | Connection type: 0h = Unknown; 1h = 1/8" stereo/mono; 2h = 1/4" stereo/mono; 3h = ATAPI internal; 4h = RCA; 5h = Optical; 6h = Other digital; 7h = Other analog; 8h = Multichannel analog (DIN); 9h = XLR/Professional; Ah = RJ-11 (modem); Bh = Combination; Ch-Eh = Reserved; Fh = Other |
| [15..12] | Color | RW | 0 | Color: 0h = Unknown; 1h = Black; 2h = Grey; 3h = Blue; 4h = Green; 5h = Red; 6h = Orange; 7h = Yellow; 8h = Purple; 9h = Pink; Ah-Dh = Reserved; Eh = White; Fh = Other |
| [11..8] | Misc | RW | 1 | Miscellaneous: Bits [3..1] = Reserved; Bit 0 = Jack detect override |
| [7..4] | Association | RW | 2 | Default association. |
| [3..0] | Sequence | RW | E | Sequence. |

6.12. DMic0 Node (NID = 13)

6.12.1. DMic0 WCap

| | Verb ID | Payload | Response |
|-----|---------|---------|---------------------|
| Get | F00 | 09 | See bitfield table. |

6.12.1.1. DMic0 WCap

| Bit | Bitfield Name | RW | Reset | Description |
|----------|---------------|----|-------|---|
| [31.:24] | Rsvd2 | R | 00 | Reserved. |
| [23.:20] | Type | R | 4 | Widget type: 0h = Out Converter; 1h = In Converter; 2h = Summing (Mixer); 3h = Selector (Mux); 4h = Pin Complex; 5h = Power; 6h = Volume Knob; 7h = Beep Generator; 8h-Eh = Reserved; Fh = Vendor Defined |
| [19.:16] | Delay | R | 0 | Number of sample delays through widget. |
| [15.:12] | Rsvd1 | R | 0 | Reserved. |
| [11] | SwapCap | R | 0 | Left/right swap support: 1 = yes 0 = no. |
| [10] | PwrCntrl | R | 0 | Power state support: 1 = yes 0 = no. |
| [9] | DigitalStrm | R | 0 | Digital stream support: 1 = yes (digital) 0 = no (analog). |
| [8] | ConnList | R | 0 | Connection list present: 1 = yes 0 = no. |
| [7] | UnsolCap | R | 0 | Unsolicited response support: 1 = yes 0 = no. |
| [6] | ProcWidget | R | 0 | Processing state support: 1 = yes 0 = no. |
| [5] | Stripe | R | 0 | Striping support: 1 = yes 0 = no. |
| [4] | FormatOvrd | R | 0 | Stream format override: 1 = yes 0 = no. |
| [3] | AmpParOvrd | R | 0 | Amplifier capabilities override: 1 = yes no. |
| [2] | OutAmpPrsnt | R | 0 | Output amp present: 1 = yes 0 = no. |

6.12.1.1. *DMic0 WCap*

| Bit | Bitfield Name | RW | Reset | Description |
|-----|---------------|----|-------|---|
| [1] | InAmpPrsnt | R | 1 | Input amp present: 1 = yes 0 = no. |
| [0] | Stereo | R | 1 | Stereo stream support: 1 = yes (stereo) 0 = no (mono). |

6.12.2. *DMic0 PinCap*

| | Verb ID | Payload | Response |
|-----|---------|---------|---------------------|
| Get | F00 | 0C | See bitfield table. |

6.12.2.1. *DMic0 PinCap*

| Bit | Bitfield Name | RW | Reset | Description |
|----------|---------------|----|-------|--|
| [31.:17] | Rsvd2 | R | 0000 | Reserved. |
| [16] | EapdCap | R | 0 | EAPD support: 1 = yes 0 = no. |
| [15.:8] | VRefCntrl | R | 00 | Vref support: bit 7 = Reserved; bit 6 = Reserved; bit 5 = 100% support (1 = yes 0 = no); bit 4 = 80% support (1 = yes 0 = no); bit 3 = Reserved; bit 2 = GND support (1 = yes 0 = no); bit 1 = 50% support (1 = yes 0 = no); bit 0 = Hi-Z support (1 = yes 0 = no) |
| [7] | Rsvd1 | R | 0 | Reserved. |
| [6] | BalancedIO | R | 0 | Balanced I/O support: 1 = yes 0 = no. |
| [5] | InCap | R | 1 | Input support: 1 = yes 0 = no. |
| [4] | OutCap | R | 0 | Output support: 1 = yes 0 = no. |
| [3] | HPhnDrvCap | R | 0 | Headphone amp present: 1 = yes 0 = no. |
| [2] | PresDtctCap | R | 0 | Presence detection support: 1 = yes 0 = no. |

6.12.2.1. *DMic0 PinCap*

| Bit | Bitfield Name | RW | Reset | Description |
|-----|---------------|----|-------|---|
| [1] | TrigRqd | R | 0 | Trigger required for impedance sense: 1 = yes 0 = no. |
| [0] | ImpSenseCap | R | 0 | Impedance sense support: 1 = yes 0 = no. |

6.12.3. *DMic0 PinWCntrl*

| | Verb ID | Payload | Response |
|-----|---------|---------|---------------------|
| Get | F07 | 00 | See bitfield table. |

6.12.3.1. *DMic0 PinWCntrl*

| Bit | Bitfield Name | RW | Reset | Description |
|---------|---------------|----|---------|---|
| [31..6] | Rsvd2 | R | 0000000 | Reserved. |
| [5] | InEn | RW | 0 | Input enable: 1 = enabled 0 = disabled. |
| [4..0] | Rsvd1 | R | 00 | Reserved. |

6.12.4. *DMic0 InAmpLeft*

| | Verb ID | Payload | Response |
|-----|---------|---------|---------------------|
| Get | B20 | 00 | See bitfield table. |

6.12.4.1. *DMic0 InAmpLeft*

| Bit | Bitfield Name | RW | Reset | Description |
|---------|---------------|----|--------|--|
| [31..2] | Rsvd1 | R | 000000 | Reserved. |
| [1..0] | Gain | RW | 0 | Amp gain step number (see InAmpCap parameter pertaining to this widget). |

6.12.5. DMic0 InAmpRight

| | Verb ID | Payload | Response |
|-----|---------|---------|---------------------|
| Get | B00 | 00 | See bitfield table. |

6.12.5.1. DMic0 InAmpRight

| Bit | Bitfield Name | RW | Reset | Description |
|---------|---------------|----|--------|--|
| [31..2] | Rsvd1 | R | 000000 | Reserved. |
| [1..0] | Gain | RW | 0 | Amp gain step number (see InAmpCap parameter pertaining to this widget). |

6.12.6. DMic0 ConfigDefault

| | Verb ID | Payload | Response |
|-----|---------|---------|---------------------|
| Get | F1C | 00 | See bitfield table. |

6.12.6.1. DMic0 ConfigDefault

| Bit | Bitfield Name | RW | Reset | Description |
|----------|------------------|----|-------|---|
| [31..30] | PortConnectivity | RW | 2 | Port connectivity: 0h = Port complex is connected to a jack; 1h = No physical connection for port; 2h = Fixed function device is attached; 3h = Both jack and internal device attached (info in all other fields refers to integrated device any presence detection refers to jack) |
| [29..24] | Location | RW | 10 | Location. Bits [5..4]: 0h = External on primary chassis; 1h = Internal; 2h = Separate chassis; 3h = Other. Bits [3..0]: 0h = N/A; 1h = Rear; 2h = Front; 3h = Left; 4h = Right; 5h = Top; 6h = Bottom; 7h-9h = Special; Ah-Fh = Reserved |

6.12.6.1. *DMic0 ConfigDefault*

| Bit | Bitfield Name | RW | Reset | Description |
|----------|----------------|----|-------|--|
| [23.:20] | Device | RW | A | Default device: 0h = Line out; 1h = Speaker; 2h = HP out; 3h = CD; 4h = SPDIF Out; 5h = Digital other out; 6h = Modem line side; 7h = Modem handset side; 8h = Line in; 9h = Aux; Ah = Mic in; Bh = Telephony; Ch = SPDIF In; Dh = Digital other in; Eh = Reserved; Fh = Other |
| [19.:16] | ConnectionType | RW | 3 | Connection type: 0h = Unknown; 1h = 1/8" stereo/mono; 2h = 1/4" stereo/mono; 3h = ATAPI internal; 4h = RCA; 5h = Optical; 6h = Other digital; 7h = Other analog; 8h = Multichannel analog (DIN); 9h = XLR/Professional; Ah = RJ-11 (modem); Bh = Combination; Ch-Eh = Reserved; Fh = Other |
| [15.:12] | Color | RW | 0 | Color: 0h = Unknown; 1h = Black; 2h = Grey; 3h = Blue; 4h = Green; 5h = Red; 6h = Orange; 7h = Yellow; 8h = Purple; 9h = Pink; Ah-Dh = Reserved; Eh = White; Fh = Other |
| [11.:8] | Misc | RW | 0 | Miscellaneous: Bits [3..1] = Reserved; Bit 0 = Jack detect override |
| [7.:4] | Association | RW | 7 | Default association. |
| [3.:0] | Sequence | RW | 0 | Sequence. |

6.13. **DMic1 Node (NID = 14)**6.13.1. *DMic1 WCap*

| | Verb ID | Payload | Response |
|-----|---------|---------|---------------------|
| Get | F00 | 09 | See bitfield table. |

6.13.1.1. *DMic1 WCap*

| Bit | Bitfield Name | RW | Reset | Description |
|----------|---------------|----|-------|---|
| [31.:24] | Rsvd2 | R | 00 | Reserved. |
| [23.:20] | Type | R | 4 | Widget type: 0h = Out Converter; 1h = In Converter; 2h = Summing (Mixer); 3h = Selector (Mux); 4h = Pin Complex; 5h = Power; 6h = Volume Knob; 7h = Beep Generator; 8h-Eh = Reserved; Fh = Vendor Defined |
| [19.:16] | Delay | R | 0 | Number of sample delays through widget. |
| [15.:12] | Rsvd1 | R | 0 | Reserved. |
| [11] | SwapCap | R | 0 | Left/right swap support: 1 = yes 0 = no. |
| [10] | PwrCntrl | R | 0 | Power state support: 1 = yes 0 = no. |
| [9] | DigitalStrm | R | 0 | Digital stream support: 1 = yes (digital) 0 = no (analog). |
| [8] | ConnList | R | 0 | Connection list present: 1 = yes 0 = no. |
| [7] | UnsolCap | R | 0 | Unsolicited response support: 1 = yes 0 = no. |
| [6] | ProcWidget | R | 0 | Processing state support: 1 = yes 0 = no. |
| [5] | Stripe | R | 0 | Striping support: 1 = yes 0 = no. |
| [4] | FormatOvrd | R | 0 | Stream format override: 1 = yes 0 = no. |
| [3] | AmpParOvrd | R | 0 | Amplifier capabilities override: 1 = yes no. |
| [2] | OutAmpPrsnt | R | 0 | Output amp present: 1 = yes 0 = no. |
| [1] | InAmpPrsnt | R | 1 | Input amp present: 1 = yes 0 = no. |
| [0] | Stereo | R | 1 | Stereo stream support: 1 = yes (stereo) 0 = no (mono). |

6.13.2. DMic1 PinCap

| | Verb ID | Payload | Response |
|-----|---------|---------|---------------------|
| Get | F00 | 0C | See bitfield table. |

6.13.2.1. DMic1 PinCap

| Bit | Bitfield Name | RW | Reset | Description |
|----------|---------------|----|-------|--|
| [31.:17] | Rsvd2 | R | 0000 | Reserved. |
| [16] | EapdCap | R | 0 | EAPD support: 1 = yes 0 = no. |
| [15.:8] | VRefCntrl | R | 00 | Vref support: bit 7 = Reserved; bit 6 = Reserved; bit 5 = 100% support (1 = yes 0 = no); bit 4 = 80% support (1 = yes 0 = no); bit 3 = Reserved; bit 2 = GND support (1 = yes 0 = no); bit 1 = 50% support (1 = yes 0 = no); bit 0 = Hi-Z support (1 = yes 0 = no) |
| [7] | Rsvd1 | R | 0 | Reserved. |
| [6] | BalancedIO | R | 0 | Balanced I/O support: 1 = yes 0 = no. |
| [5] | InCap | R | 1 | Input support: 1 = yes 0 = no. |
| [4] | OutCap | R | 0 | Output support: 1 = yes 0 = no. |
| [3] | HPHnDrvCap | R | 0 | Headphone amp present: 1 = yes 0 = no. |
| [2] | PresDtctCap | R | 0 | Presence detection support: 1 = yes 0 = no. |
| [1] | TrigRqd | R | 0 | Trigger required for impedance sense: 1 = yes 0 = no. |
| [0] | ImpSenseCap | R | 0 | Impedance sense support: 1 = yes 0 = no. |

6.13.3. DMic1 PinWCntrl

| | Verb ID | Payload | Response |
|-----|---------|---------|---------------------|
| Get | F07 | 00 | See bitfield table. |

6.13.3.1. DMic1 PinWCntrl

| Bit | Bitfield Name | RW | Reset | Description |
|---------|---------------|----|---------|---|
| [31..6] | Rsvd2 | R | 0000000 | Reserved. |
| [5] | InEn | RW | 0 | Input enable: 1 = enabled 0 = disabled. |
| [4..0] | Rsvd1 | R | 00 | Reserved. |

6.13.4. DMic1 InAmpLeft

| | Verb ID | Payload | Response |
|-----|---------|---------|---------------------|
| Get | B20 | 00 | See bitfield table. |

6.13.4.1. DMic1 InAmpLeft

| Bit | Bitfield Name | RW | Reset | Description |
|---------|---------------|----|--------|--|
| [31..2] | Rsvd1 | R | 000000 | Reserved. |
| [1..0] | Gain | RW | 0 | Amp gain step number (see InAmpCap parameter pertaining to this widget). |

6.13.5. DMic1 InAmpRight

| | Verb ID | Payload | Response |
|-----|---------|---------|---------------------|
| Get | B00 | 00 | See bitfield table. |

6.13.5.1. *DMic1 InAmpRight*

| Bit | Bitfield Name | RW | Reset | Description |
|---------|---------------|----|--------|--|
| [31..2] | Rsvd1 | R | 000000 | Reserved. |
| [1..0] | Gain | RW | 0 | Amp gain step number (see InAmpCap parameter pertaining to this widget). |

6.13.6. *DMic1 ConfigDefault*

| | Verb ID | Payload | Response |
|-----|---------|---------|---------------------|
| Get | F1C | 00 | See bitfield table. |

6.13.6.1. *DMic1 ConfigDefault*

| Bit | Bitfield Name | RW | Reset | Description |
|----------|------------------|----|-------|---|
| [31..30] | PortConnectivity | RW | 2 | Port connectivity: 0h = Port complex is connected to a jack; 1h = No physical connection for port; 2h = Fixed function device is attached; 3h = Both jack and internal device attached (info in all other fields refers to integrated device any presence detection refers to jack) |
| [29..24] | Location | RW | 10 | Location. Bits [5..4]: 0h = External on primary chassis; 1h = Internal; 2h = Separate chassis; 3h = Other. Bits [3..0]: 0h = N/A; 1h = Rear; 2h = Front; 3h = Left; 4h = Right; 5h = Top; 6h = Bottom; 7h-9h = Special; Ah-Fh = Reserved |
| [23..20] | Device | RW | A | Default device: 0h = Line out; 1h = Speaker; 2h = HP out; 3h = CD; 4h = SPDIF Out; 5h = Digital other out; 6h = Modem line side; 7h = Modem handset side; 8h = Line in; 9h = Aux; Ah = Mic in; Bh = Telephony; Ch = SPDIF In; Dh = Digital other in; Eh = Reserved; Fh = Other |

6.13.6.1. *DMic1 ConfigDefault*

| Bit | Bitfield Name | RW | Reset | Description |
|----------|----------------|----|-------|--|
| [19..16] | ConnectionType | RW | 3 | Connection type: 0h = Unknown; 1h = 1/8" stereo/mono; 2h = 1/4" stereo/mono; 3h = ATAPI internal; 4h = RCA; 5h = Optical; 6h = Other digital; 7h = Other analog; 8h = Multichannel analog (DIN); 9h = XLR/Professional; Ah = RJ-11 (modem); Bh = Combination; Ch-Eh = Reserved; Fh = Other |
| [15..12] | Color | RW | 0 | Color: 0h = Unknown; 1h = Black; 2h = Grey; 3h = Blue; 4h = Green; 5h = Red; 6h = Orange; 7h = Yellow; 8h = Purple; 9h = Pink; Ah-Dh = Reserved; Eh = White; Fh = Other |
| [11..8] | Misc | RW | 0 | Miscellaneous: Bits [3..1] = Reserved; Bit 0 = Jack detect override |
| [7..4] | Association | RW | 7 | Default association. |
| [3..0] | Sequence | RW | E | Sequence. |

6.14. DAC0 Node (NID = 15)

6.14.1. *DAC0 WCap*

| | Verb ID | Payload | Response |
|-----|---------|---------|---------------------|
| Get | F00 | 09 | See bitfield table. |

6.14.1.1. *DAC0 WCap*

| Bit | Bitfield Name | RW | Reset | Description |
|----------|---------------|----|-------|---|
| [31..24] | Rsvd2 | R | 00 | Reserved. |
| [23..20] | Type | R | 0 | Widget type: 0h = Out Converter; 1h = In Converter; 2h = Summing (Mixer); 3h = Selector (Mux); 4h = Pin Complex; 5h = Power; 6h = Volume Knob; 7h = Beep Generator; 8h-Eh = Reserved; Fh = Vendor Defined |

6.14.1.1. *DAC0 WCap*

| Bit | Bitfield Name | RW | Reset | Description |
|----------|---------------|----|-------|---|
| [19.:16] | Delay | R | D | Number of sample delays through widget. |
| [15.:12] | Rsvd1 | R | 0 | Reserved. |
| [11] | SwapCap | R | 1 | Left/right swap support: 1 = yes 0 = no. |
| [10] | PwrCntrl | R | 1 | Power state support: 1 = yes 0 = no. |
| [9] | Dig | R | 0 | Digital stream support: 1 = yes (digital) 0 = no (analog). |
| [8] | ConnList | R | 0 | Connection list present: 1 = yes 0 = no. |
| [7] | UnSolCap | R | 0 | Unsolicited response support: 1 = yes 0 = no. |
| [6] | ProcWidget | R | 0 | Processing state support: 1 = yes 0 = no. |
| [5] | Stripe | R | 0 | Striping support: 1 = yes 0 = no. |
| [4] | FormatOvrd | R | 0 | Stream format override: 1 = yes 0 = no. |
| [3] | AmpParOvrd | R | 0 | Amplifier capabilities override: 1 = yes no. |
| [2] | OutAmpPrsnt | R | 1 | Output amp present: 1 = yes 0 = no. |
| [1] | InAmpPrsnt | R | 0 | Input amp present: 1 = yes 0 = no. |
| [0] | Stereo | R | 1 | Stereo stream support: 1 = yes (stereo) 0 = no (mono). |

6.14.2. *DAC0 Cnvtr*

| | Verb ID | Payload | Response |
|-----|---------|---------|---------------------|
| Get | A | 0000 | See bitfield table. |

6.14.2.1. *DAC0 Cnvtr*

| Bit | Bitfield Name | RW | Reset | Description |
|----------|---------------|----|-------|--|
| [31..16] | Rsvd2 | R | 0000 | Reserved. |
| [15] | StrmType | R | 0 | Stream type: 1 = Non-PCM 0 = PCM. |
| [14] | FrmtSmplRate | RW | 0 | Sample base rate: 1 = 44.1kHz 0 = 48kHz. |
| [13..11] | SmplRateMultp | RW | 0 | Sample base rate multiple: 000b= x1 (48kHz/44.1kHz or less); 001b= x2 (96kHz/88.2kHz/32kHz); 010b= x3 (144kHz); 011b= x4 (192kHz/176.4kHz); 100b-111b Reserved |
| [10..8] | SmplRateDiv | RW | 0 | Sample base rate divider: 000b= Divide by 1 (48kHz/44.1kHz); 001b= Divide by 2 (24kHz/20.05kHz); 010b= Divide by 3 (16kHz/32kHz); 011b= Divide by 4 (11.025kHz); 100b= Divide by 5 (9.6kHz); 101b= Divide by 6 (8kHz); 110b= Divide by 7; 111b= Divide by 8 (6kHz) |
| [7] | Rsvd1 | R | 0 | Reserved. |
| [6..4] | BitsPerSmpl | RW | 3 | Bits per sample: 000b= 8 bits; 001b= 16 bits; 010b= 20 bits; 011b= 24 bits; 100b= 32 bits; 101b-111b= Reserved |
| [3..0] | NmbrChan | RW | 1 | Total number of channels in the stream assigned to this converter: 0000b-1111b= 1-16 channels. |

6.14.3. *DAC0 OutAmpLeft*

| | Verb ID | Payload | Response |
|-----|---------|---------|---------------------|
| Get | BA0 | 00 | See bitfield table. |

6.14.3.1. DAC0 OutAmpLeft

| Bit | Bitfield Name | RW | Reset | Description |
|---------|---------------|----|--------|--|
| [31.:8] | Rsvd | R | 000000 | Reserved. |
| [7] | Mute | RW | 1 | Amp mute: 1 = muted 0 = not muted. |
| [6.:0] | Gain | RW | 7F | Amp gain step number (see OutAmp-Cap parameter pertaining to this widget). |

6.14.4. DAC0 OutAmpRight

| | Verb ID | Payload | Response |
|-----|---------|---------|---------------------|
| Get | B80 | 00 | See bitfield table. |

6.14.4.1. DAC0 OutAmpRight

| Bit | Bitfield Name | RW | Reset | Description |
|---------|---------------|----|--------|--|
| [31.:8] | Rsvd | R | 000000 | Reserved. |
| [7] | Mute | RW | 1 | Amp mute: 1 = muted 0 = not muted. |
| [6.:0] | Gain | RW | 7F | Amp gain step number (see OutAmp-Cap parameter pertaining to this widget). |

6.14.5. DAC0 PwrState

| | Verb ID | Payload | Response |
|-----|---------|---------|---------------------|
| Get | F05 | 00 | See bitfield table. |

6.14.5.1. *DAC0 PwrState*

| Bit | Bitfield Name | RW | Reset | Description |
|---------|---------------|----|---------|--|
| [31..6] | Rsvd2 | R | 0000000 | Reserved. |
| [5..4] | Act | R | 3 | Actual power state of this widget. |
| [3..2] | Rsvd1 | R | 0 | Reserved. |
| [1..0] | Set | RW | 3 | Current power state setting for this widget. |

6.14.6. *DAC0 CnvtrID*

| | Verb ID | Payload | Response |
|-----|---------|---------|---------------------|
| Get | F06 | 00 | See bitfield table. |

6.14.6.1. *DAC0 CnvtrID*

| Bit | Bitfield Name | RW | Reset | Description |
|---------|---------------|----|--------|---|
| [31..8] | Rsvd | R | 000000 | Reserved. |
| [7..4] | Strm | RW | 0 | Stream ID: 0h = Converter "off" 1h-Fh = valid IDs. |
| [3..0] | Ch | RW | 0 | Channel assignment ("Ch" and "Ch+1" assigned as a pair for a stereo converter). |

6.14.7. *DAC0 LR*

| | Verb ID | Payload | Response |
|-----|---------|---------|---------------------|
| Get | F0C | 00 | See bitfield table. |

6.14.7.1. DAC0 LR

| Bit | Bitfield Name | RW | Reset | Description |
|---------|---------------|----|----------|--|
| [31.:3] | Rsvd2 | R | 00000000 | Reserved. |
| [2] | SwapEn | RW | 0 | Swap enable: 1 = L/R swap enabled 0 = L/R swap disabled. |
| [1.:0] | Rsvd1 | R | 0 | Reserved. |

6.15. DAC1 Node (NID = 16)

6.15.1. DAC1 WCap

| | Verb ID | Payload | Response |
|-----|---------|---------|---------------------|
| Get | F00 | 09 | See bitfield table. |

6.15.1.1. DAC1 WCap

| Bit | Bitfield Name | RW | Reset | Description |
|----------|---------------|----|-------|---|
| [31.:24] | Rsvd2 | R | 00 | Reserved. |
| [23.:20] | Type | R | 0 | Widget type: 0h = Out Converter; 1h = In Converter; 2h = Summing (Mixer); 3h = Selector (Mux); 4h = Pin Complex; 5h = Power; 6h = Volume Knob; 7h = Beep Generator; 8h-Eh = Reserved; Fh = Vendor Defined |
| [19.:16] | Delay | R | D | Number of sample delays through widget. |
| [15.:12] | Rsvd1 | R | 0 | Reserved. |
| [11] | SwapCap | R | 1 | Left/right swap support: 1 = yes 0 = no. |
| [10] | PwrCntrl | R | 1 | Power state support: 1 = yes 0 = no. |
| [9] | Dig | R | 0 | Digital stream support: 1 = yes (digital) 0 = no (analog). |

6.15.1.1. *DAC1 WCap*

| Bit | Bitfield Name | RW | Reset | Description |
|-----|---------------|----|-------|--|
| [8] | ConnList | R | 0 | Connection list present: 1 = yes 0 = no. |
| [7] | UnSolCap | R | 0 | Unsolicited response support: 1 = yes 0 = no. |
| [6] | ProcWidget | R | 0 | Processing state support: 1 = yes 0 = no. |
| [5] | Stripe | R | 0 | Striping support: 1 = yes 0 = no. |
| [4] | FormatOvrd | R | 0 | Stream format override: 1 = yes 0 = no. |
| [3] | AmpParOvrd | R | 0 | Amplifier capabilities override: 1 = yes no. |
| [2] | OutAmpPrsnt | R | 1 | Output amp present: 1 = yes 0 = no. |
| [1] | InAmpPrsnt | R | 0 | Input amp present: 1 = yes 0 = no. |
| [0] | Stereo | R | 1 | Stereo stream support: 1 = yes (stereo) 0 = no (mono). |

6.15.2. *DAC1 Cnvtr*

| | Verb ID | Payload | Response |
|-----|---------|---------|---------------------|
| Get | A00 | 00 | See bitfield table. |

6.15.2.1. *DAC1 Cnvtr*

| Bit | Bitfield Name | RW | Reset | Description |
|----------|---------------|----|-------|--|
| [31..16] | Rsvd2 | R | 0000 | Reserved. |
| [15] | StrmType | R | 0 | Stream type: 1 = Non-PCM 0 = PCM. |
| [14] | FrmtSmplRate | RW | 0 | Sample base rate: 1 = 44.1kHz 0 = 48kHz. |

6.15.2.1. DAC1 Cnvtr

| Bit | Bitfield Name | RW | Reset | Description |
|----------|---------------|----|-------|--|
| [13.:11] | SmplRateMultp | RW | 0 | Sample base rate multiple: 000b= x1 (48kHz/44.1kHz or less); 001b= x2 (96kHz/88.2kHz/32kHz); 010b= x3 (144kHz); 011b= x4 (192kHz/176.4kHz); 100b-111b Reserved |
| [10.:8] | SmplRateDiv | RW | 0 | Sample base rate divider: 000b= Divide by 1 (48kHz/44.1kHz); 001b= Divide by 2 (24kHz/20.05kHz); 010b= Divide by 3 (16kHz/32kHz); 011b= Divide by 4 (11.025kHz); 100b= Divide by 5 (9.6kHz); 101b= Divide by 6 (8kHz); 110b= Divide by 7; 111b= Divide by 8 (6kHz) |
| [7] | Rsvd1 | R | 0 | Reserved. |
| [6.:4] | BitsPerSmpl | RW | 3 | Bits per sample: 000b= 8 bits; 001b= 16 bits; 010b= 20 bits; 011b= 24 bits; 100b= 32 bits; 101b-111b= Reserved |
| [3.:0] | NmbrChan | RW | 1 | Total number of channels in the stream assigned to this converter: 0000b-1111b= 1-16 channels. |

6.15.3. DAC1 OutAmpLeft

| | Verb ID | Payload | Response |
|-----|---------|---------|---------------------|
| Get | BA0 | 00 | See bitfield table. |

6.15.3.1. DAC1 OutAmpLeft

| Bit | Bitfield Name | RW | Reset | Description |
|---------|---------------|----|--------|-------------|
| [31.:8] | Rsvd | R | 000000 | Reserved. |

6.15.3.1. DAC1 OutAmpLeft

| Bit | Bitfield Name | RW | Reset | Description |
|--------|---------------|----|-------|--|
| [7] | Mute | RW | 1 | Amp mute: 1 = muted 0 = not muted. |
| [6.:0] | Gain | RW | 7F | Amp gain step number (see OutAmp-Cap parameter pertaining to this widget). |

6.15.4. DAC1 OutAmpRight

| | Verb ID | Payload | Response |
|-----|---------|---------|---------------------|
| Get | B80 | 00 | See bitfield table. |

6.15.4.1. DAC1 OutAmpRight

| Bit | Bitfield Name | RW | Reset | Description |
|---------|---------------|----|--------|--|
| [31.:8] | Rsvd | R | 000000 | Reserved. |
| [7] | Mute | RW | 1 | Amp mute: 1 = muted 0 = not muted. |
| [6.:0] | Gain | RW | 7F | Amp gain step number (see OutAmp-Cap parameter pertaining to this widget). |

6.15.5. DAC1 PwrState

| | Verb ID | Payload | Response |
|-----|---------|---------|---------------------|
| Get | F05 | 00 | See bitfield table. |

6.15.5.1. DAC1 PwrState

| Bit | Bitfield Name | RW | Reset | Description |
|---------|---------------|----|---------|--|
| [31..6] | Rsvd2 | R | 0000000 | Reserved. |
| [5..4] | Act | R | 3 | Actual power state of this widget. |
| [3..2] | Rsvd1 | R | 0 | Reserved. |
| [1..0] | Set | RW | 3 | Current power state setting for this widget. |

6.15.6. DAC1 CnvtrID

| | Verb ID | Payload | Response |
|-----|---------|---------|---------------------|
| Get | F06 | 00 | See bitfield table. |

6.15.6.1. DAC1 CnvtrID

| Bit | Bitfield Name | RW | Reset | Description |
|---------|---------------|----|--------|---|
| [31..8] | Rsvd | R | 000000 | Reserved. |
| [7..4] | Strm | RW | 0 | Stream ID: 0h = Converter "off" 1h-Fh = valid IDs. |
| [3..0] | Ch | RW | 0 | Channel assignment ("Ch" and "Ch+1" assigned as a pair for a stereo converter). |

6.15.7. DAC1 LR

| | Verb ID | Payload | Response |
|-----|---------|---------|---------------------|
| Get | F0C | 00 | See bitfield table. |

6.15.7.1. DAC1 LR

| Bit | Bitfield Name | RW | Reset | Description |
|---------|---------------|----|----------|--|
| [31.:3] | Rsvd2 | R | 00000000 | Reserved. |
| [2] | SwapEn | RW | 0 | Swap enable: 1 = L/R swap enabled 0 = L/R swap disabled. |
| [1.:0] | Rsvd1 | R | 0 | Reserved. |

6.16. DAC2 Node (NID = 17)

6.16.1. DAC2 WCap

| | Verb ID | Payload | Response |
|-----|---------|---------|---------------------|
| Get | F00 | 09 | See bitfield table. |

6.16.1.1. DAC2 WCap

| Bit | Bitfield Name | RW | Reset | Description |
|----------|---------------|----|-------|---|
| [31.:24] | Rsvd2 | R | 00 | Reserved. |
| [23.:20] | Type | R | 0 | Widget type: 0h = Out Converter; 1h = In Converter; 2h = Summing (Mixer); 3h = Selector (Mux); 4h = Pin Complex; 5h = Power; 6h = Volume Knob; 7h = Beep Generator; 8h-Eh = Reserved; Fh = Vendor Defined |
| [19.:16] | Delay | R | D | Number of sample delays through widget. |
| [15.:12] | Rsvd1 | R | 0 | Reserved. |
| [11] | SwapCap | R | 1 | Left/right swap support: 1 = yes 0 = no. |
| [10] | PwrCntrl | R | 1 | Power state support: 1 = yes 0 = no. |
| [9] | Dig | R | 0 | Digital stream support: 1 = yes (digital) 0 = no (analog). |

6.16.1.1. DAC2 WCap

| Bit | Bitfield Name | RW | Reset | Description |
|-----|---------------|----|-------|---|
| [8] | ConnList | R | 0 | Connection list present: 1 = yes 0 = no. |
| [7] | UnSolCap | R | 0 | Unsolicited response support: 1 = yes 0 = no. |
| [6] | ProcWidget | R | 0 | Processing state support: 1 = yes 0 = no. |
| [5] | Stripe | R | 0 | Striping support: 1 = yes 0 = no. |
| [4] | FormatOvrd | R | 0 | Stream format override: 1 = yes 0 = no. |
| [3] | AmpParOvrd | R | 0 | Amplifier capabilities override: 1 = yes no. |
| [2] | OutAmpPrsnt | R | 1 | Output amp present: 1 = yes 0 = no. |
| [1] | InAmpPrsnt | R | 0 | Input amp present: 1 = yes 0 = no. |
| [0] | Stereo | R | 1 | Stereo stream support: 1 = yes (stereo) 0 = no (mono). |

6.16.2. DAC2 Cnvtr

| | Verb ID | Payload | Response |
|-----|---------|---------|---------------------|
| Get | A00 | 00 | See bitfield table. |

6.16.2.1. DAC2 Cnvtr

| Bit | Bitfield Name | RW | Reset | Description |
|----------|---------------|----|-------|--|
| [31..16] | Rsvd2 | R | 0000 | Reserved. |
| [15] | StrmType | R | 0 | Stream type: 1 = Non-PCM 0 = PCM. |
| [14] | FrmtSmplRate | RW | 0 | Sample base rate: 1 = 44.1kHz 0 = 48kHz. |

6.16.2.1. DAC2 Cnvtr

| Bit | Bitfield Name | RW | Reset | Description |
|----------|---------------|----|-------|--|
| [13.:11] | SmplRateMultp | RW | 0 | Sample base rate multiple: 000b= x1 (48kHz/44.1kHz or less); 001b= x2 (96kHz/88.2kHz/32kHz); 010b= x3 (144kHz); 011b= x4 (192kHz/176.4kHz); 100b-111b Reserved |
| [10.:8] | SmplRateDiv | RW | 0 | Sample base rate divider: 000b= Divide by 1 (48kHz/44.1kHz); 001b= Divide by 2 (24kHz/20.05kHz); 010b= Divide by 3 (16kHz/32kHz); 011b= Divide by 4 (11.025kHz); 100b= Divide by 5 (9.6kHz); 101b= Divide by 6 (8kHz); 110b= Divide by 7; 111b= Divide by 8 (6kHz) |
| [7] | Rsvd1 | R | 0 | Reserved. |
| [6.:4] | BitsPerSmpl | RW | 3 | Bits per sample: 000b= 8 bits; 001b= 16 bits; 010b= 20 bits; 011b= 24 bits; 100b= 32 bits; 101b-111b= Reserved |
| [3.:0] | NmbrChan | RW | 1 | Total number of channels in the stream assigned to this converter: 0000b-1111b= 1-16 channels. |

6.16.3. DAC2 OutAmpLeft

| | Verb ID | Payload | Response |
|-----|---------|---------|---------------------|
| Get | BA0 | 00 | See bitfield table. |

6.16.3.1. DAC2 OutAmpLeft

| Bit | Bitfield Name | RW | Reset | Description |
|---------|---------------|----|--------|-------------|
| [31.:8] | Rsvd | R | 000000 | Reserved. |

6.16.3.1. DAC2 OutAmpLeft

| Bit | Bitfield Name | RW | Reset | Description |
|--------|---------------|----|-------|--|
| [7] | Mute | RW | 1 | Amp mute: 1 = muted 0 = not muted. |
| [6.:0] | Gain | RW | 7F | Amp gain step number (see OutAmp-Cap parameter pertaining to this widget). |

6.16.4. DAC2 OutAmpRight

| | Verb ID | Payload | Response |
|-----|---------|---------|---------------------|
| Get | B80 | 00 | See bitfield table. |

6.16.4.1. DAC2 OutAmpRight

| Bit | Bitfield Name | RW | Reset | Description |
|---------|---------------|----|--------|--|
| [31.:8] | Rsvd | R | 000000 | Reserved. |
| [7] | Mute | RW | 1 | Amp mute: 1 = muted 0 = not muted. |
| [6.:0] | Gain | RW | 7F | Amp gain step number (see OutAmp-Cap parameter pertaining to this widget). |

6.16.5. DAC2 PwrState

| | Verb ID | Payload | Response |
|-----|---------|---------|---------------------|
| Get | F05 | 00 | See bitfield table. |

6.16.5.1. *DAC2 PwrState*

| Bit | Bitfield Name | RW | Reset | Description |
|---------|---------------|----|---------|--|
| [31..6] | Rsvd2 | R | 0000000 | Reserved. |
| [5..4] | Act | R | 3 | Actual power state of this widget. |
| [3..2] | Rsvd1 | R | 0 | Reserved. |
| [1..0] | Set | RW | 3 | Current power state setting for this widget. |

6.16.6. *DAC2 CnvtrID*

| | Verb ID | Payload | Response |
|-----|---------|---------|---------------------|
| Get | F06 | 00 | See bitfield table. |

6.16.6.1. *DAC2 CnvtrID*

| Bit | Bitfield Name | RW | Reset | Description |
|---------|---------------|----|--------|---|
| [31..8] | Rsvd | R | 000000 | Reserved. |
| [7..4] | Strm | RW | 0 | Stream ID: 0h = Converter "off" 1h-Fh = valid IDs. |
| [3..0] | Ch | RW | 0 | Channel assignment ("Ch" and "Ch+1" assigned as a pair for a stereo converter). |

6.16.7. *DAC2 LR*

| | Verb ID | Payload | Response |
|-----|---------|---------|---------------------|
| Get | F0C | 00 | See bitfield table. |

6.16.7.1. DAC2 LR

| Bit | Bitfield Name | RW | Reset | Description |
|---------|---------------|----|----------|--|
| [31..3] | Rsvd2 | R | 00000000 | Reserved. |
| [2] | SwapEn | RW | 0 | Swap enable: 1 = L/R swap enabled 0 = L/R swap disabled. |
| [1..0] | Rsvd1 | R | 0 | Reserved. |

6.17. Reserved (NID = 18)

6.18. Reserved (NID = 19)

6.19. ADC0 Node (NID = 1A)

6.19.1. ADC0 WCap

| | Verb ID | Payload | Response |
|-----|---------|---------|---------------------|
| Get | F00 | 09 | See bitfield table. |

6.19.1.1. ADC0 WCap

| Bit | Bitfield Name | RW | Reset | Description |
|----------|---------------|----|-------|---|
| [31..24] | Rsvd2 | R | 00 | Reserved. |
| [23..20] | Type | R | 1 | Widget type: 0h = Out Converter; 1h = In Converter; 2h = Summing (Mixer); 3h = Selector (Mux); 4h = Pin Complex; 5h = Power; 6h = Volume Knob; 7h = Beep Generator; 8h-Eh = Reserved; Fh = Vendor Defined |
| [19..16] | Delay | R | D | Number of sample delays through widget. |
| [15..12] | Rsvd1 | R | 0 | Reserved. |
| [11] | SwapCap | R | 0 | Left/right swap support: 1 = yes 0 = no. |

6.19.1.1. *ADC0 WCap*

| Bit | Bitfield Name | RW | Reset | Description |
|------|---------------|----|-------|---|
| [10] | PwrCntrl | R | 1 | Power state support: 1 = yes 0 = no. |
| [9] | Dig | R | 0 | Digital stream support: 1 = yes (digital) 0 = no (analog). |
| [8] | ConnList | R | 1 | Connection list present: 1 = yes 0 = no. |
| [7] | UnSolCap | R | 0 | Unsolicited response support: 1 = yes 0 = no. |
| [6] | ProcWidget | R | 1 | Processing state support: 1 = yes 0 = no. |
| [5] | Stripe | R | 0 | Striping support: 1 = yes 0 = no. |
| [4] | FormatOvrd | R | 0 | Stream format override: 1 = yes 0 = no. |
| [3] | AmpParOvrd | R | 0 | Amplifier capabilities override: 1 = yes no. |
| [2] | OutAmpPrsnt | R | 0 | Output amp present: 1 = yes 0 = no. |
| [1] | InAmpPrsnt | R | 0 | Input amp present: 1 = yes 0 = no. |
| [0] | Stereo | R | 1 | Stereo stream support: 1 = yes (stereo) 0 = no (mono). |

6.19.2. *ADC0 ConLst*

| | Verb ID | Payload | Response |
|-----|---------|---------|---------------------|
| Get | F00 | 0E | See bitfield table. |

6.19.2.1. *ADC0 ConLst*

| Bit | Bitfield Name | RW | Reset | Description |
|---------|---------------|----|--------|-------------|
| [31..8] | Rsvd | R | 000000 | Reserved. |

6.19.2.1. *ADC0 ConLst*

| Bit | Bitfield Name | RW | Reset | Description |
|--------|---------------|----|-------|--|
| [7] | LForm | R | 0 | Connection list format: 1 = long-form (15-bit) NID entries 0 = short-form (7-bit) NID entries. |
| [6..0] | ConL | R | 01 | Number of NID entries in connection list. |

6.19.3. *ADC0 ConLstEntry0*

| | Verb ID | Payload | Response |
|-----|---------|---------|---------------------|
| Get | F02 | 00 | See bitfield table. |

6.19.3.1. *ADC0 ConLstEntry0*

| Bit | Bitfield Name | RW | Reset | Description |
|----------|---------------|----|-------|--------------------------------|
| [31..24] | ConL3 | R | 00 | Unused list entry. |
| [23..16] | ConL2 | R | 00 | Unused list entry. |
| [15..8] | ConL1 | R | 00 | Unused list entry. |
| [7..0] | ConL0 | R | 20 | ADC0Mux Selector widget (0x20) |

6.19.4. *ADC0 Cnvtr*

| | Verb ID | Payload | Response |
|-----|---------|---------|---------------------|
| Get | A | 0000 | See bitfield table. |

6.19.4.1. *ADC0 Cnvtr*

| Bit | Bitfield Name | RW | Reset | Description |
|----------|---------------|----|-------|--|
| [31..16] | Rsvd2 | R | 0000 | Reserved. |
| [15] | StrmType | R | 0 | Stream type: 1 = Non-PCM 0 = PCM. |
| [14] | FrmtSmplRate | RW | 0 | Sample base rate: 1 = 44.1kHz 0 = 48kHz. |
| [13..11] | SmplRateMultp | RW | 0 | Sample base rate multiple: 000b= x1 (48kHz/44.1kHz or less); 001b= x2 (96kHz/88.2kHz/32kHz); 010b= x3 (144kHz); 011b= x4 (192kHz/176.4kHz); 100b-111b Reserved |
| [10..8] | SmplRateDiv | RW | 0 | Sample base rate divider: 000b= Divide by 1 (48kHz/44.1kHz); 001b= Divide by 2 (24kHz/20.05kHz); 010b= Divide by 3 (16kHz/32kHz); 011b= Divide by 4 (11.025kHz); 100b= Divide by 5 (9.6kHz); 101b= Divide by 6 (8kHz); 110b= Divide by 7; 111b= Divide by 8 (6kHz) |
| [7] | Rsvd1 | R | 0 | Reserved. |
| [6..4] | BitsPerSmpl | RW | 3 | Bits per sample: 000b= 8 bits; 001b= 16 bits; 010b= 20 bits; 011b= 24 bits; 100b= 32 bits; 101b-111b= Reserved |
| [3..0] | NmbrChan | RW | 1 | Total number of channels in the stream assigned to this converter: 0000b-1111b= 1-16 channels. |

6.19.5. *ADC0 ProcState*

| | Verb ID | Payload | Response |
|-----|---------|---------|---------------------|
| Get | F03 | 00 | See bitfield table. |

6.19.5.1. *ADC0 ProcState*

| Bit | Bitfield Name | RW | Reset | Description |
|---------|---------------|----|--------|---|
| [31..8] | Rsvd2 | R | 000000 | Reserved. |
| [7] | HPFOCDIS | RW | 0 | HPF offset calculation disable. 1 = calculation disabled; 0 = calculation enabled. |
| [6..2] | Rsvd1 | R | 00 | Reserved. |
| [1..0] | ADCHPFByP | RW | 1 | Processing State: 00b= bypass the ADC HPF ("off") 01b-11b= ADC HPF is enabled ("on" or "benign"). |

6.19.6. *ADC0 PwrState*

| | Verb ID | Payload | Response |
|-----|---------|---------|---------------------|
| Get | F05 | 00 | See bitfield table. |

6.19.6.1. *ADC0 PwrState*

| Bit | Bitfield Name | RW | Reset | Description |
|---------|---------------|----|---------|--|
| [31..6] | Rsvd2 | R | 0000000 | Reserved. |
| [5..4] | Act | R | 3 | Actual power state of this widget. |
| [3..2] | Rsvd1 | R | 0 | Reserved. |
| [1..0] | Set | RW | 3 | Current power state setting for this widget. |

6.19.7. *ADC0 CnvtrID*

| | Verb ID | Payload | Response |
|-----|---------|---------|---------------------|
| Get | F06 | 00 | See bitfield table. |

6.19.7.1. *ADC0 CnvtrID*

| Bit | Bitfield Name | RW | Reset | Description |
|---------|---------------|----|--------|---|
| [31..8] | Rsvd | R | 000000 | Reserved. |
| [7..4] | Strm | RW | 0 | Stream ID: 0h = Converter "off" 1h-Fh = valid IDs. |
| [3..0] | Ch | RW | 0 | Channel assignment ("Ch" and "Ch+1" assigned as a pair for a stereo converter). |

6.20. ADC1 Node (NID = 1B)

6.20.1. *ADC1 WCap*

| | Verb ID | Payload | Response |
|-----|---------|---------|---------------------|
| Get | F00 | 09 | See bitfield table. |

6.20.1.1. *ADC1 WCap*

| Bit | Bitfield Name | RW | Reset | Description |
|----------|---------------|----|-------|---|
| [31..24] | Rsvd2 | R | 00 | Reserved. |
| [23..20] | Type | R | 1 | Widget type: 0h = Out Converter; 1h = In Converter; 2h = Summing (Mixer); 3h = Selector (Mux); 4h = Pin Complex; 5h = Power; 6h = Volume Knob; 7h = Beep Generator; 8h-Eh = Reserved; Fh = Vendor Defined |
| [19..16] | Delay | R | D | Number of sample delays through widget. |
| [15..12] | Rsvd1 | R | 0 | Reserved. |
| [11] | SwapCap | R | 0 | Left/right swap support: 1 = yes 0 = no. |
| [10] | PwrCntrl | R | 1 | Power state support: 1 = yes 0 = no. |

6.20.1.1. *ADC1 WCap*

| Bit | Bitfield Name | RW | Reset | Description |
|-----|---------------|----|-------|---|
| [9] | Dig | R | 0 | Digital stream support: 1 = yes (digital) 0 = no (analog). |
| [8] | ConnList | R | 1 | Connection list present: 1 = yes 0 = no. |
| [7] | UnSolCap | R | 0 | Unsolicited response support: 1 = yes 0 = no. |
| [6] | ProcWidget | R | 1 | Processing state support: 1 = yes 0 = no. |
| [5] | Stripe | R | 0 | Striping support: 1 = yes 0 = no. |
| [4] | FormatOvrd | R | 0 | Stream format override: 1 = yes 0 = no. |
| [3] | AmpParOvrd | R | 0 | Amplifier capabilities override: 1 = yes no. |
| [2] | OutAmpPrsnt | R | 0 | Output amp present: 1 = yes 0 = no. |
| [1] | InAmpPrsnt | R | 0 | Input amp present: 1 = yes 0 = no. |
| [0] | Stereo | R | 1 | Stereo stream support: 1 = yes (stereo) 0 = no (mono). |

6.20.2. *ADC1 ConLst*

| | Verb ID | Payload | Response |
|-----|---------|---------|---------------------|
| Get | F00 | 0E | See bitfield table. |

6.20.2.1. *ADC1 ConLst*

| Bit | Bitfield Name | RW | Reset | Description |
|---------|---------------|----|--------|--|
| [31..8] | Rsvd | R | 000000 | Reserved. |
| [7] | LForm | R | 0 | Connection list format: 1 = long-form (15-bit) NID entries 0 = short-form (7-bit) NID entries. |
| [6.:0] | ConL | R | 01 | Number of NID entries in connection list. |

6.20.3. ADC1 ConLstEntry0

| | Verb ID | Payload | Response |
|-----|---------|---------|---------------------|
| Get | F02 | 00 | See bitfield table. |

6.20.3.1. ADC1 ConLstEntry0

| Bit | Bitfield Name | RW | Reset | Description |
|----------|---------------|----|-------|-----------------------|
| [31..24] | ConL3 | R | 00 | Unused list entry. |
| [23..16] | ConL2 | R | 00 | Unused list entry. |
| [15..8] | ConL1 | R | 00 | Unused list entry. |
| [7..0] | ConL0 | R | 21 | ADC1Mux widget (0x21) |

6.20.4. ADC1 Cnvtr

| | Verb ID | Payload | Response |
|-----|---------|---------|---------------------|
| Get | A00 | 00 | See bitfield table. |

6.20.4.1. ADC1 Cnvtr

| Bit | Bitfield Name | RW | Reset | Description |
|----------|---------------|----|-------|--|
| [31..16] | Rsvd2 | R | 0000 | Reserved. |
| [15] | StrmType | R | 0 | Stream type: 1 = Non-PCM 0 = PCM. |
| [14] | FrmtSmplRate | RW | 0 | Sample base rate: 1 = 44.1kHz 0 = 48kHz. |
| [13..11] | SmplRateMultp | RW | 0 | Sample base rate multiple: 000b= x1 (48kHz/44.1kHz or less); 001b= x2 (96kHz/88.2kHz/32kHz); 010b= x3 (144kHz); 011b= x4 (192kHz/176.4kHz); 100b-111b Reserved |

6.20.4.1. ADC1 Cnvtr

| Bit | Bitfield Name | RW | Reset | Description |
|---------|---------------|----|-------|--|
| [10.:8] | SmplRateDiv | RW | 0 | Sample base rate divider: 000b= Divide by 1 (48kHz/44.1kHz); 001b= Divide by 2 (24kHz/20.05kHz); 010b= Divide by 3 (16kHz/32kHz); 011b= Divide by 4 (11.025kHz); 100b= Divide by 5 (9.6kHz); 101b= Divide by 6 (8kHz); 110b= Divide by 7; 111b= Divide by 8 (6kHz) |
| [7] | Rsvd1 | R | 0 | Reserved. |
| [6.:4] | BitsPerSmpl | RW | 3 | Bits per sample: 000b= 8 bits; 001b= 16 bits; 010b= 20 bits; 011b= 24 bits; 100b= 32 bits; 101b-111b= Reserved |
| [3.:0] | NmbrChan | RW | 1 | Total number of channels in the stream assigned to this converter: 0000b-1111b= 1-16 channels. |

6.20.5. ADC1 ProcState

| | Verb ID | Payload | Response |
|-----|---------|---------|---------------------|
| Get | F03 | 00 | See bitfield table. |

6.20.5.1. ADC1 ProcState

| Bit | Bitfield Name | RW | Reset | Description |
|---------|---------------|----|--------|---|
| [31.:8] | Rsvd2 | R | 000000 | Reserved. |
| [7] | HPFOCDIS | RW | 0 | HPF offset calculation disable. 1 = calculation disabled; 0 = calculation enabled. |
| [6.:2] | Rsvd1 | R | 00 | Reserved. |
| [1.:0] | ADCHPFByp | RW | 1 | Processing State: 00b= bypass the ADC HPF ("off") 01b-11b= ADC HPF is enabled ("on" or "benign"). |

6.20.6. ADC1 PwrState

| | Verb ID | Payload | Response |
|-----|---------|---------|---------------------|
| Get | F05 | 00 | See bitfield table. |

6.20.6.1. ADC1 PwrState

| Bit | Bitfield Name | RW | Reset | Description |
|---------|---------------|----|---------|--|
| [31..6] | Rsvd2 | R | 0000000 | Reserved. |
| [5..4] | Act | R | 3 | Actual power state of this widget. |
| [3..2] | Rsvd1 | R | 0 | Reserved. |
| [1..0] | Set | RW | 3 | Current power state setting for this widget. |

6.20.7. ADC1 CnvtrID

| | Verb ID | Payload | Response |
|-----|---------|---------|---------------------|
| Get | F06 | 00 | See bitfield table. |

6.20.7.1. ADC1 CnvtrID

| Bit | Bitfield Name | RW | Reset | Description |
|---------|---------------|----|--------|---|
| [31..8] | Rsvd | R | 000000 | Reserved. |
| [7..4] | Strm | RW | 0 | Stream ID: 0h = Converter "off" 1h-Fh = valid IDs. |
| [3..0] | Ch | RW | 0 | Channel assignment ("Ch" and "Ch+1" assigned as a pair for a stereo converter). |

6.21. DigBeep Node (NID = 1C)

6.21.1. DigBeep WCap

| | Verb ID | Payload | Response |
|-----|---------|---------|---------------------|
| Get | F00 | 09 | See bitfield table. |

6.21.1.1. DigBeep WCap

| Bit | Bitfield Name | RW | Reset | Description |
|----------|---------------|----|-------|---|
| [31.:24] | Rsvd3 | R | 00 | Reserved. |
| [23.:20] | Type | R | 7 | Widget type: 0h = Out Converter; 1h = In Converter; 2h = Summing (Mixer); 3h = Selector (Mux); 4h = Pin Complex; 5h = Power; 6h = Volume Knob; 7h = Beep Generator; 8h-Eh = Reserved; Fh = Vendor Defined |
| [19.:4] | Rsvd2 | R | 0 | Reserved. |
| [3] | AmpParOvrd | R | 1 | Amplifier capabilities override: 1 = yes, no. |
| [2] | OutAmpPrsnt | R | 1 | Output amp present: 1 = yes, 0 = no. |
| [1.:0] | Rsvd1 | R | 0 | Reserved. |

6.21.2. DigBeep OutAmpCap

| | Verb ID | Payload | Response |
|-----|---------|---------|---------------------|
| Get | F00 | 12 | See bitfield table. |

6.21.2.1. *DigBeep OutAmpCap*

| Bit | Bitfield Name | RW | Reset | Description |
|----------|---------------|----|-------|--|
| [31] | Mute | R | 1 | Mute support: 1 = yes, 0 = no. |
| [30.:23] | Rsvd3 | R | 00 | Reserved. |
| [22.:16] | StepSize | R | 17 | Size of each step in the gain range: 0 to 127 = .25dB to 32dB, in .25dB steps. |
| [15] | Rsvd2 | R | 0 | Reserved. |
| [14.:8] | NumSteps | R | 03 | Number of gains steps (number of possible settings - 1). |
| [7] | Rsvd1 | R | 0 | Reserved. |
| [6.:0] | Offset | R | 03 | Indicates which step is 0dB |

6.21.3. *DigBeep OutAmpLeft*

| | Verb ID | Payload | Response |
|-----|---------|---------|---------------------|
| Get | BA0 | 00 | See bitfield table. |

6.21.3.1. *DigBeep OutAmpLeft*

| Bit | Bitfield Name | RW | Reset | Description |
|---------|---------------|----|--------|--|
| [31.:8] | Rsvd2 | R | 000000 | Reserved. |
| [7] | Mute | RW | 0 | Amp mute: 1 = muted, 0 = not muted. |
| [6.:2] | Rsvd1 | R | 00 | Reserved. |
| [1.:0] | Gain | RW | 0 | Amp gain step number (see OutAmp-Cap parameter pertaining to this widget). |

6.21.4. DigBeep Gen

| | Verb ID | Payload | Response |
|-----|---------|---------|---------------------|
| Get | F0A | 00 | See bitfield table. |

6.21.4.1. DigBeep Gen

| Bit | Bitfield Name | RW | Reset | Description |
|---------|---------------|----|--------|--|
| [31..8] | Rsvd | R | 000000 | Reserved. |
| [7.:0] | Divider | RW | 00 | Enable internal PC-Beep generation. Divider == 00h disables internal PC Beep generation and enables normal operation of the codec. Divider != 00h generates the beep tone on all Pin Complexes that are currently configured as outputs. The HD Audio spec states that the beep tone frequency = (48kHz HD Audio SYNC rate) / (4*Divider), producing tones from 47 Hz to 12 kHz (logarithmic scale). This part can selectively generate tones with frequency = 48KHz * (257 - Divider) / 1024, yielding a linear range from 12kHz to 93.75Hz in steps of 46.875Hz. If the FreqShift bit is set, then the beep tones generated have frequency = 48KHz * (513 - Divider) / 1024, yielding a range of 24kHz to 12093.75Hz in steps of 46.875Hz. |

6.22. Mixer Node (NID = 1D)**6.22.1. Mixer WCap**

| | Verb ID | Payload | Response |
|-----|---------|---------|---------------------|
| Get | F00 | 09 | See bitfield table. |

6.22.1.1. MonoMixer WCap

| Bit | Bitfield Name | RW | Reset | Description |
|----------|---------------|----|-------|---|
| [31.:24] | Rsvd2 | R | 00 | Reserved. |
| [23.:20] | Type | R | 2 | Widget type: 0h = Out Converter; 1h = In Converter; 2h = Summing (Mixer); 3h = Selector (Mux); 4h = Pin Complex; 5h = Power; 6h = Volume Knob; 7h = Beep Generator; 8h-Eh = Reserved; Fh = Vendor Defined |
| [19.:16] | Delay | R | 0 | Number of sample delays through widget. |
| [15.:12] | Rsvd1 | R | 0 | Reserved. |
| [11] | SwapCap | R | 0 | Left/right swap support: 1 = yes 0 = no. |
| [10] | PwrCntrl | R | 0 | Power state support: 1 = yes 0 = no. |
| [9] | Dig | R | 0 | Digital stream support: 1 = yes (digital) 0 = no (analog). |
| [8] | ConnList | R | 1 | Connection list present: 1 = yes 0 = no. |
| [7] | UnSolCap | R | 0 | Unsolicited response support: 1 = yes 0 = no. |
| [6] | ProcWidget | R | 0 | Processing state support: 1 = yes 0 = no. |
| [5] | Stripe | R | 0 | Striping support: 1 = yes 0 = no. |
| [4] | FormatOvrd | R | 0 | Stream format override: 1 = yes 0 = no. |
| [3] | AmpParOvrd | R | 1 | Amplifier capabilities override: 1 = yes no. |
| [2] | OutAmpPrsnt | R | 0 | Output amp present: 1 = yes 0 = no. |
| [1] | InAmpPrsnt | R | 1 | Input amp present: 1 = yes 0 = no. |
| [0] | Stereo | R | 1 | Stereo stream support: 1 = yes (stereo) 0 = no (mono). |

6.22.2. Mixer ConLst

| | Verb ID | Payload | Response |
|-----|---------|---------|---------------------|
| Get | F00 | 0E | See bitfield table. |

6.22.2.1. Mixer ConLst

| Bit | Bitfield Name | RW | Reset | Description |
|---------|---------------|----|--------|--|
| [31..8] | Rsvd | R | 000000 | Reserved. |
| [7] | LForm | R | 0 | Connection list format: 1 = long-form (15-bit) NID entries 0 = short-form (7-bit) NID entries. |
| [6..0] | ConL | R | 03 | Number of NID entries in connection list. |

6.22.3. Mixer ConLstEntry0

| | Verb ID | Payload | Response |
|-----|---------|---------|---------------------|
| Get | F02 | 00 | See bitfield table. |

6.22.3.1. Mixer ConLstEntry0

| Bit | Bitfield Name | RW | Reset | Description |
|----------|---------------|----|-------|--|
| [31..24] | ConL3 | R | 00 | Unused list entry. |
| [23..16] | ConL2 | R | 12 | Port I Pin Widget (CD In) (0x12),. Uses InAmpLeft5/InAmpRight5 controls |
| [15] | ConL1Range | R | 2B | 1 = ConL0..ConL1 defines a range of selectable inputs. |
| [14..8] | ConL1 | R | 2B | InPort3Mux Selector widget (0x2B). Uses InAmpLeft3/InAmpRight3 controls. |
| [7..0] | ConL0 | R | 28 | InPort0Mux Selector widget (0x28). Uses InAmpLeft0/InAmpRight0 controls. |

6.22.4. Mixer InAmpCap

| | Verb ID | Payload | Response |
|-----|---------|---------|---------------------|
| Get | F00 | 0D | See bitfield table. |

6.22.4.1. Mixer InAmpCap

| Bit | Bitfield Name | RW | Reset | Description |
|----------|---------------|----|-------|---|
| [31] | Mute | R | 1 | Mute support: 1 = yes 0 = no. |
| [30.:23] | Rsvd3 | R | 00 | Reserved. |
| [22.:16] | StepSize | R | 05 | Size of each step in the gain range: 0 to 127 = .25dB to 32dB in .25dB steps. |
| [15] | Rsvd2 | R | 0 | Reserved. |
| [14.:8] | NumSteps | R | 1F | Number of gains steps (number of possible settings - 1). |
| [7] | Rsvd1 | R | 0 | Reserved. |
| [6.:0] | Offset | R | 17 | Indicates which step is 0dB |

6.22.5. Mixer InAmpLeft0

| | Verb ID | Payload | Response |
|-----|---------|---------|---------------------|
| Get | B20 | 00 | See bitfield table. |

6.22.5.1. Mixer InAmpLeft0

| Bit | Bitfield Name | RW | Reset | Description |
|---------|---------------|----|--------|------------------------------------|
| [31.:8] | Rsvd2 | R | 000000 | Reserved. |
| [7] | Mute | RW | 1 | Amp mute: 1 = muted 0 = not muted. |

6.22.5.1. *Mixer InAmpLeft0*

| Bit | Bitfield Name | RW | Reset | Description |
|--------|---------------|----|-------|--|
| [6.:5] | Rsvd1 | R | 0 | Reserved. |
| [4.:0] | Gain | RW | 17 | Amp gain step number (see InAmpCap parameter pertaining to this widget). |

6.22.6. *Mixer InAmpRight0*

| | Verb ID | Payload | Response |
|-----|---------|---------|---------------------|
| Get | B00 | 00 | See bitfield table. |

6.22.6.1. *Mixer InAmpRight0*

| Bit | Bitfield Name | RW | Reset | Description |
|---------|---------------|----|--------|--|
| [31.:8] | Rsvd2 | R | 000000 | Reserved. |
| [7] | Mute | RW | 1 | Amp mute: 1 = muted 0 = not muted. |
| [6.:5] | Rsvd1 | R | 0 | Reserved. |
| [4.:0] | Gain | RW | 17 | Amp gain step number (see InAmpCap parameter pertaining to this widget). |

6.22.7. *Mixer InAmpLeft1*

| | Verb ID | Payload | Response |
|-----|---------|---------|---------------------|
| Get | B20 | 01 | See bitfield table. |

6.22.7.1. Mixer InAmpLeft1

| Bit | Bitfield Name | RW | Reset | Description |
|---------|---------------|----|--------|--|
| [31.:8] | Rsvd2 | R | 000000 | Reserved. |
| [7] | Mute | RW | 1 | Amp mute: 1 = muted 0 = not muted. |
| [6.:5] | Rsvd1 | R | 0 | Reserved. |
| [4.:0] | Gain | RW | 17 | Amp gain step number (see InAmpCap parameter pertaining to this widget). |

6.22.8. Mixer InAmpRight1

| | Verb ID | Payload | Response |
|-----|---------|---------|---------------------|
| Get | B00 | 01 | See bitfield table. |

6.22.8.1. Mixer InAmpRight1

| Bit | Bitfield Name | RW | Reset | Description |
|---------|---------------|----|--------|--|
| [31.:8] | Rsvd2 | R | 000000 | Reserved. |
| [7] | Mute | RW | 1 | Amp mute: 1 = muted 0 = not muted. |
| [6.:5] | Rsvd1 | R | 0 | Reserved. |
| [4.:0] | Gain | RW | 17 | Amp gain step number (see InAmpCap parameter pertaining to this widget). |

6.22.9. Mixer InAmpLeft2

| | Verb ID | Payload | Response |
|-----|---------|---------|---------------------|
| Get | B20 | 02 | See bitfield table. |

6.22.9.1. Mixer InAmpLeft2

| Bit | Bitfield Name | RW | Reset | Description |
|---------|---------------|----|--------|--|
| [31.:8] | Rsvd2 | R | 000000 | Reserved. |
| [7] | Mute | RW | 1 | Amp mute: 1 = muted 0 = not muted. |
| [6.:5] | Rsvd1 | R | 0 | Reserved. |
| [4.:0] | Gain | RW | 17 | Amp gain step number (see InAmpCap parameter pertaining to this widget). |

6.22.10. Mixer InAmpRight2

| | Verb ID | Payload | Response |
|-----|---------|---------|---------------------|
| Get | B00 | 02 | See bitfield table. |

6.22.10.1. Mixer InAmpRight0

| Bit | Bitfield Name | RW | Reset | Description |
|---------|---------------|----|--------|--|
| [31.:8] | Rsvd2 | R | 000000 | Reserved. |
| [7] | Mute | RW | 1 | Amp mute: 1 = muted 0 = not muted. |
| [6.:5] | Rsvd1 | R | 0 | Reserved. |
| [4.:0] | Gain | RW | 17 | Amp gain step number (see InAmpCap parameter pertaining to this widget). |

6.22.11. Mixer InAmpLeft3

| | Verb ID | Payload | Response |
|-----|---------|---------|---------------------|
| Get | B20 | 03 | See bitfield table. |

6.22.11.1. Mixer InAmpLeft3

| Bit | Bitfield Name | RW | Reset | Description |
|---------|---------------|----|--------|--|
| [31.:8] | Rsvd2 | R | 000000 | Reserved. |
| [7] | Mute | RW | 1 | Amp mute: 1 = muted 0 = not muted. |
| [6.:5] | Rsvd1 | R | 0 | Reserved. |
| [4.:0] | Gain | RW | 17 | Amp gain step number (see InAmpCap parameter pertaining to this widget). |

6.22.12. Mixer InAmpRight3

| | Verb ID | Payload | Response |
|-----|---------|---------|---------------------|
| Get | B00 | 03 | See bitfield table. |

6.22.12.1. Mixer InAmpRight3

| Bit | Bitfield Name | RW | Reset | Description |
|---------|---------------|----|--------|--|
| [31.:8] | Rsvd2 | R | 000000 | Reserved. |
| [7] | Mute | RW | 1 | Amp mute: 1 = muted 0 = not muted. |
| [6.:5] | Rsvd1 | R | 0 | Reserved. |
| [4.:0] | Gain | RW | 17 | Amp gain step number (see InAmpCap parameter pertaining to this widget). |

6.22.13. Mixer InAmpLeft4

| | Verb ID | Payload | Response |
|-----|---------|---------|---------------------|
| Get | B20 | 04 | See bitfield table. |

6.22.13.1. Mixer InAmpLeft4

| Bit | Bitfield Name | RW | Reset | Description |
|---------|---------------|----|--------|--|
| [31.:8] | Rsvd2 | R | 000000 | Reserved. |
| [7] | Mute | RW | 1 | Amp mute: 1 = muted 0 = not muted. |
| [6.:5] | Rsvd1 | R | 0 | Reserved. |
| [4.:0] | Gain | RW | 17 | Amp gain step number (see InAmpCap parameter pertaining to this widget). |

6.22.14. Mixer InAmpRight4

| | Verb ID | Payload | Response |
|-----|---------|---------|---------------------|
| Get | B00 | 04 | See bitfield table. |

6.22.14.1. Mixer InAmpRight0

| Bit | Bitfield Name | RW | Reset | Description |
|---------|---------------|----|--------|--|
| [31.:8] | Rsvd2 | R | 000000 | Reserved. |
| [7] | Mute | RW | 1 | Amp mute: 1 = muted 0 = not muted. |
| [6.:5] | Rsvd1 | R | 0 | Reserved. |
| [4.:0] | Gain | RW | 17 | Amp gain step number (see InAmpCap parameter pertaining to this widget). |

6.23. MixerOutVol Node (NID = 1E)**6.23.1. MixerOutVol WCap**

| | Verb ID | Payload | Response |
|-----|---------|---------|---------------------|
| Get | F00 | 09 | See bitfield table. |

6.23.1.1. MonoMixer WCap

| Bit | Bitfield Name | RW | Reset | Description |
|----------|---------------|----|-------|---|
| [31.:24] | Rsvd2 | R | 00 | Reserved. |
| [23.:20] | Type | R | 3 | Widget type: 0h = Out Converter; 1h = In Converter; 2h = Summing (Mixer); 3h = Selector (Mux); 4h = Pin Complex; 5h = Power; 6h = Volume Knob; 7h = Beep Generator; 8h-Eh = Reserved; Fh = Vendor Defined |
| [19.:16] | Delay | R | 0 | Number of sample delays through widget. |
| [15.:12] | Rsvd1 | R | 0 | Reserved. |
| [11] | SwapCap | R | 0 | Left/right swap support: 1 = yes 0 = no. |
| [10] | PwrCntrl | R | 0 | Power state support: 1 = yes 0 = no. |
| [9] | Dig | R | 0 | Digital stream support: 1 = yes (digital) 0 = no (analog). |
| [8] | ConnList | R | 1 | Connection list present: 1 = yes 0 = no. |
| [7] | UnSolCap | R | 0 | Unsolicited response support: 1 = yes 0 = no. |
| [6] | ProcWidget | R | 0 | Processing state support: 1 = yes 0 = no. |
| [5] | Stripe | R | 0 | Striping support: 1 = yes 0 = no. |
| [4] | FormatOvrd | R | 0 | Stream format override: 1 = yes 0 = no. |
| [3] | AmpParOvrd | R | 1 | Amplifier capabilities override: 1 = yes no. |
| [2] | OutAmpPrsnt | R | 1 | Output amp present: 1 = yes 0 = no. |
| [1] | InAmpPrsnt | R | 1 | Input amp present: 1 = yes 0 = no. |
| [0] | Stereo | R | 1 | Stereo stream support: 1 = yes (stereo) 0 = no (mono). |

6.23.2. MixerOutVol ConLst

| | Verb ID | Payload | Response |
|-----|---------|---------|---------------------|
| Get | F00 | 0E | See bitfield table. |

6.23.2.1. MixerOutVol ConLst

| Bit | Bitfield Name | RW | Reset | Description |
|---------|---------------|----|--------|--|
| [31..8] | Rsvd | R | 000000 | Reserved. |
| [7] | LForm | R | 0 | Connection list format: 1 = long-form (15-bit) NID entries 0 = short-form (7-bit) NID entries. |
| [6..0] | ConL | R | 1 | Number of NID entries in connection list. |

6.23.3. MixerOutVol ConLstEntry0

| | Verb ID | Payload | Response |
|-----|---------|---------|---------------------|
| Get | F02 | 00 | See bitfield table. |

6.23.3.1. Mixer ConLstEntry0

| Bit | Bitfield Name | RW | Reset | Description |
|----------|---------------|----|-------|-----------------------------|
| [31..24] | ConL3 | R | 00 | Unused list entry. |
| [23..16] | ConL2 | R | 00 | Unused list entry. |
| [15..8] | ConL1 | R | 00 | Unused list entry. |
| [7..0] | ConL0 | R | 1D | Mixer Summing widget (0x1D) |

6.23.4. MixerOutVol OutAmpCap

| | Verb ID | Payload | Response |
|-----|---------|---------|---------------------|
| Get | F00 | 12 | See bitfield table. |

6.23.4.1. MixerOutVol OutAmpCap

| Bit | Bitfield Name | RW | Reset | Description |
|----------|---------------|----|-------|---|
| [31] | Mute | R | 0 | Mute support: 1 = yes 0 = no. |
| [30.:23] | Rsvd3 | R | 00 | Reserved. |
| [22.:16] | StepSize | R | 05 | Size of each step in the gain range: 0 to 127 = .25dB to 32dB in .25dB steps. |
| [15] | Rsvd2 | R | 0 | Reserved. |
| [14.:8] | NumSteps | R | 1F | Number of gains steps (number of possible settings - 1). |
| [7] | Rsvd1 | R | 0 | Reserved. |
| [6.:0] | Offset | R | 1F | Indicates which step is 0dB |

6.23.5. MixerOutVol OutAmpLeft

| | Verb ID | Payload | Response |
|-----|---------|---------|---------------------|
| Get | BA0 | 00 | See bitfield table. |

6.23.5.1. MixerOutVol OutAmpLeft

| Bit | Bitfield Name | RW | Reset | Description |
|---------|---------------|----|--------|------------------------------------|
| [31.:8] | Rsvd2 | R | 000000 | Reserved. |
| [7] | Mute | RW | 1 | Amp mute: 1 = muted 0 = not muted. |

6.23.5.1. *MixerOutVol OutAmpLeft*

| Bit | Bitfield Name | RW | Reset | Description |
|--------|---------------|----|-------|--|
| [6.:5] | Rsvd1 | R | 0 | Reserved. |
| [4.:0] | Gain | RW | 1F | Amp gain step number (see OutAmp-Cap parameter pertaining to this widget). |

6.23.6. *MixerOutVol OutAmpRight0*

| | Verb ID | Payload | Response |
|-----|---------|---------|---------------------|
| Get | B80 | 00 | See bitfield table. |

6.23.6.1. *MixerOutVol OutAmpRight*

| Bit | Bitfield Name | RW | Reset | Description |
|---------|---------------|----|--------|--|
| [31.:8] | Rsvd2 | R | 000000 | Reserved. |
| [7] | Mute | RW | 1 | Amp mute: 1 = muted 0 = not muted. |
| [6.:5] | Rsvd1 | R | 0 | Reserved. |
| [4.:0] | Gain | RW | 1F | Amp gain step number (see OutAmp-Cap parameter pertaining to this widget). |

6.24. VolumeKnob Node (NID = 1F)

6.24.1. *VolumeKnob WCap*

| | Verb ID | Payload | Response |
|-----|---------|---------|---------------------|
| Get | F00 | 09 | See bitfield table. |

6.24.1.1. *VolumeKnob WCap*

| Bit | Bitfield Name | RW | Reset | Description |
|----------|---------------|----|-------|---|
| [31.:24] | Rsvd2 | R | 00 | Reserved. |
| [23.:20] | Type | R | 6 | Widget type: 0h = Out Converter; 1h = In Converter; 2h = Summing (Mixer); 3h = Selector (Mux); 4h = Pin Complex; 5h = Power; 6h = Volume Knob; 7h = Beep Generator; 8h-Eh = Reserved; Fh = Vendor Defined |
| [19.:0] | Rsvd1 | R | 0 | Reserved. |

6.24.2. *VolumeKnob VolKnobCap*

| | Verb ID | Payload | Response |
|-----|---------|---------|---------------------|
| Get | F00 | 13 | See bitfield table. |

6.24.2.1. *VolumeKnob VolKnobCap*

| Bit | Bitfield Name | RW | Reset | Description |
|---------|---------------|----|--------|---|
| [31.:8] | Rsvd | R | 000000 | Reserved. |
| [7] | Delta | R | 1 | Indicates if software can write a base volume to the Volume Control Knob. |
| [6.:0] | NumSteps | R | 7F | Number of gains steps (number of possible settings - 1). |

6.24.3. *VolumeKnob ConLst*

| | Verb ID | Payload | Response |
|-----|---------|---------|---------------------|
| Get | F00 | 0E | See bitfield table. |

6.24.3.1. *VolumeKnob ConLst*

| Bit | Bitfield Name | RW | Reset | Description |
|---------|---------------|----|--------|---|
| [31..8] | Rsvd | R | 000000 | Reserved. |
| [7] | LForm | R | 0 | Connection list format: 1 = long-form (15-bit) NID entries, 0 = short-form (7-bit) NID entries. |
| [6..0] | ConL | R | 02 | Number of NID entries in connection list. |

6.24.4. *VolumeKnob ConLstEntry0*

| | Verb ID | Payload | Response |
|-----|---------|---------|---------------------|
| Get | F02 | 00 | See bitfield table. |

6.24.4.1. *VolumeKnob ConLstEntry0*

| Bit | Bitfield Name | RW | Reset | Description |
|----------|---------------|----|-------|--|
| [31..24] | ConL3 | R | 00 | Unused list entry. |
| [23..16] | ConL2 | R | 00 | Unused list entry. |
| [15] | ConL1Range | R | 1 | 1 = ConL0..ConL1 defines a range of selectable inputs. |
| [14..8] | ConL1 | R | 17 | DAC2 Converter widget (0x17) |
| [7..0] | ConL0 | R | 15 | DAC0 Converter widget (0x15) |

6.24.5. *VolumeKnob UnsolResp*

| | Verb ID | Payload | Response |
|-----|---------|---------|---------------------|
| Get | F08 | 00 | See bitfield table. |

6.24.5.1. *VolumeKnob UnsolicitedResponse*

| Bit | Bitfield Name | RW | Reset | Description |
|---------|---------------|----|--------|--|
| [31..8] | Rsvd2 | R | 000000 | Reserved. |
| [7] | En | RW | 0 | Unsolicited response enable: 1 = enabled, 0 = disabled. |
| [6] | Rsvd1 | R | 0 | Reserved. |
| [5..0] | Tag | RW | 00 | Software programmable field returned in top six bits (31:26) of every Unsolicited Response generated by this node. |

6.24.6. *VolumeKnob Control*

| | Verb ID | Payload | Response |
|-----|---------|---------|---------------------|
| Get | F0F | 00 | See bitfield table. |

6.24.6.1. *VolumeKnob Control*

| Bit | Bitfield Name | RW | Reset | Description |
|---------|---------------|----|--------|--|
| [31..8] | Rsvd | R | 000000 | Reserved. |
| [7] | Direct | RW | 0 | Direct = 1 causes the volume control to directly control the hardware volume of the slave amps. Direct = 0 causes unsolicited responses to be generated. |
| [6..0] | Volume | RW | 7F | Volume, specified in steps of amplifier gain |

6.24.7. *VolumeKnob VS*

| | Verb ID | Payload | Response |
|-----|---------|---------|---------------------|
| Get | FE0 | 00 | See bitfield table. |

6.24.7.1. *VolumeKnob VS*

| Bit | Bitfield Name | RW | Reset | Description |
|---------|---------------|----|---------|---|
| [31..3] | Rsvd | R | 0000000 | Reserved. |
| [4] | Continuous | RW | 1 | Allow continuous incrementing/decrementing of the volume knob value. |
| [3..1] | Rate | RW | 0 | Volume knob update rate, for continuous mode and de-bouncing (0..7 = 2.5..20Hz, in increments of 2.5Hz) |
| [0] | Enable | RW | 0 | Volume knob enable: 0 = DMic uses external pins, 1 = Volume knob uses external pins. |

6.25. ADC0Mux Node (NID = 20)

6.25.1. *ADC0Mux WCap*

| | Verb ID | Payload | Response |
|-----|---------|---------|---------------------|
| Get | F00 | 09 | See bitfield table. |

6.25.1.1. *ADC0Mux WCap*

| Bit | Bitfield Name | RW | Reset | Description |
|----------|---------------|----|-------|---|
| [31..24] | Rsvd2 | R | 00 | Reserved. |
| [23..20] | Type | R | 3 | Widget type: 0h = Out Converter; 1h = In Converter; 2h = Summing (Mixer); 3h = Selector (Mux); 4h = Pin Complex; 5h = Power; 6h = Volume Knob; 7h = Beep Generator; 8h-Eh = Reserved; Fh = Vendor Defined |
| [19..16] | Delay | R | 0 | Number of sample delays through widget. |
| [15..12] | Rsvd1 | R | 0 | Reserved. |
| [11] | SwapCap | R | 1 | Left/right swap support: 1 = yes 0 = no. |

6.25.1.1. *ADC0Mux WCap*

| Bit | Bitfield Name | RW | Reset | Description |
|------|---------------|----|-------|---|
| [10] | PwrCntrl | R | 0 | Power state support: 1 = yes 0 = no. |
| [9] | DigitalStrm | R | 0 | Digital stream support: 1 = yes (digital) 0 = no (analog). |
| [8] | ConnList | R | 1 | Connection list present: 1 = yes 0 = no. |
| [7] | UnsolCap | R | 0 | Unsolicited response support: 1 = yes 0 = no. |
| [6] | ProcWidget | R | 0 | Processing state support: 1 = yes 0 = no. |
| [5] | Stripe | R | 0 | Striping support: 1 = yes 0 = no. |
| [4] | FormatOvrd | R | 0 | Stream format override: 1 = yes 0 = no. |
| [3] | AmpParamOvrd | R | 1 | Amplifier capabilities override: 1 = yes no. |
| [2] | OutAmpPrsnt | R | 1 | Output amp present: 1 = yes 0 = no. |
| [1] | InAmpPrsnt | R | 0 | Input amp present: 1 = yes 0 = no. |
| [0] | Stereo | R | 1 | Stereo stream support: 1 = yes (stereo) 0 = no (mono). |

6.25.2. *ADC0Mux ConLst*

| | Verb ID | Payload | Response |
|-----|---------|---------|---------------------|
| Get | F00 | 0E | See bitfield table. |

6.25.2.1. *ADC0Mux ConLst*

| Bit | Bitfield Name | RW | Reset | Description |
|---------|---------------|----|--------|-------------|
| [31..8] | Rsvd | R | 000000 | Reserved. |

6.25.2.1. *ADC0Mux ConLst*

| Bit | Bitfield Name | RW | Reset | Description |
|--------|---------------|----|-------|--|
| [7] | LForm | R | 0 | Connection list format: 1 = long-form (15-bit) NID entries 0 = short-form (7-bit) NID entries. |
| [6.:0] | ConL | R | 03 | Number of NID entries in connection list. |

6.25.3. *ADC0Mux ConLstEntry0*

| | Verb ID | Payload | Response |
|-----|---------|---------|---------------------|
| Get | F02 | 00 | See bitfield table. |

6.25.3.1. *ADC0Mux ConLstEntry0*

| Bit | Bitfield Name | RW | Reset | Description |
|----------|---------------|----|-------|---|
| [31.:24] | ConL3 | R | 00 | Unused list entry |
| [23.:16] | ConL2 | R | 1D | Mixer Summing widget (0x1D) |
| [15] | ConL1Range | R | 1 | 1 = ConL0..ConL1 defines a range of selectable inputs |
| [14.:8] | ConL1 | R | 14 | DMic1 Pin widget (0x14) |
| [7.:0] | ConL0 | R | 0A | Port A Pin widget (0x0A) |

6.25.4. *ADC0Mux ConSelectCtrl*

| | Verb ID | Payload | Response |
|-----|---------|---------|---------------------|
| Get | F01 | 00 | See bitfield table. |

6.25.4.1. *ADC0Mux ConSelectCtrl*

| Bit | Bitfield Name | RW | Reset | Description |
|---------|---------------|----|----------|----------------------------------|
| [31..4] | Rsvd | R | 00000000 | Reserved. |
| [3:0] | Index | RW | 0 | Connection select control index. |

6.25.5. *ADC0Mux LR*

| | Verb ID | Payload | Response |
|-----|---------|---------|---------------------|
| Get | F0C | 00 | See bitfield table. |

6.25.5.1. *ADC0Mux LR*

| Bit | Bitfield Name | RW | Reset | Description |
|---------|---------------|----|----------|--|
| [31..3] | Rsvd2 | R | 00000000 | Reserved. |
| [2] | SwapEn | RW | 0 | Swap enable: 1 = L/R swap enabled 0 = L/R swap disabled. |
| [1..0] | Rsvd1 | R | 0 | Reserved. |

6.25.6. *ADC0Mux OutAmpCap*

| | Verb ID | Payload | Response |
|-----|---------|---------|---------------------|
| Get | F00 | 12 | See bitfield table. |

6.25.6.1. *ADC0Mux OutAmpCap*

| Bit | Bitfield Name | RW | Reset | Description |
|----------|---------------|----|-------|---|
| [31] | Mute | R | 1 | Mute support: 1 = yes 0 = no. |
| [30..23] | Rsvd3 | R | 00 | Reserved. |
| [22..16] | StepSize | R | 05 | Size of each step in the gain range: 0 to 127 = .25dB to 32dB in .25dB steps. |
| [15] | Rsvd2 | R | 0 | Reserved. |
| [14..8] | NumSteps | R | 0F | Number of gains steps (number of possible settings - 1). |
| [7] | Rsvd1 | R | 0 | Reserved. |
| [6..0] | Offset | R | 00 | Indicates which step is 0dB |

6.25.7. *ADC0Mux OutAmpLeft*

| | Verb ID | Payload | Response |
|-----|---------|---------|---------------------|
| Get | BA0 | 00 | See bitfield table. |

6.25.7.1. *ADC0Mux OutAmpLeft*

| Bit | Bitfield Name | RW | Reset | Description |
|---------|---------------|----|--------|---|
| [31..8] | Rsvd2 | R | 000000 | Reserved. |
| [7] | Mute | RW | 1 | Amp mute: 1 = muted 0 = not muted. |
| [6..4] | Rsvd1 | R | 0 | Reserved. |
| [3..0] | Gain | RW | 0 | Amp gain step number (see OutAmpCap parameter pertaining to this widget). |

6.25.8. ADC0Mux OutAmpRight

| | Verb ID | Payload | Response |
|-----|---------|---------|---------------------|
| Get | B80 | 00 | See bitfield table. |

6.25.8.1. ADC0Mux OutAmpRight

| Bit | Bitfield Name | RW | Reset | Description |
|---------|---------------|----|--------|--|
| [31..8] | Rsvd2 | R | 000000 | Reserved. |
| [7] | Mute | RW | 1 | Amp mute: 1 = muted 0 = not muted. |
| [6..4] | Rsvd1 | R | 0 | Reserved. |
| [3..0] | Gain | RW | 0 | Amp gain step number (see OutAmp-Cap parameter pertaining to this widget). |

6.26. ADC1Mux Node (NID = 21)**6.26.1. ADC1Mux WCap**

| | Verb ID | Payload | Response |
|-----|---------|---------|---------------------|
| Get | F00 | 09 | See bitfield table. |

6.26.1.1. ADC1Mux WCap

| Bit | Bitfield Name | RW | Reset | Description |
|----------|---------------|----|-------|---|
| [31..24] | Rsvd2 | R | 00 | Reserved. |
| [23..20] | Type | R | 3 | Widget type: 0h = Out Converter; 1h = In Converter; 2h = Summing (Mixer); 3h = Selector (Mux); 4h = Pin Complex; 5h = Power; 6h = Volume Knob; 7h = Beep Generator; 8h-Eh = Reserved; Fh = Vendor Defined |

6.26.1.1. *ADC1Mux WCap*

| Bit | Bitfield Name | RW | Reset | Description |
|----------|---------------|----|-------|---|
| [19.:16] | Delay | R | 0 | Number of sample delays through widget. |
| [15.:12] | Rsvd1 | R | 0 | Reserved. |
| [11] | SwapCap | R | 1 | Left/right swap support: 1 = yes 0 = no. |
| [10] | PwrCntrl | R | 0 | Power state support: 1 = yes 0 = no. |
| [9] | DigitalStrm | R | 0 | Digital stream support: 1 = yes (digital) 0 = no (analog). |
| [8] | ConnList | R | 1 | Connection list present: 1 = yes 0 = no. |
| [7] | UnsolCap | R | 0 | Unsolicited response support: 1 = yes 0 = no. |
| [6] | ProcWidget | R | 0 | Processing state support: 1 = yes 0 = no. |
| [5] | Stripe | R | 0 | Striping support: 1 = yes 0 = no. |
| [4] | FormatOvrd | R | 0 | Stream format override: 1 = yes 0 = no. |
| [3] | AmpParamOvrd | R | 1 | Amplifier capabilities override: 1 = yes no. |
| [2] | OutAmpPrsnt | R | 1 | Output amp present: 1 = yes 0 = no. |
| [1] | InAmpPrsnt | R | 0 | Input amp present: 1 = yes 0 = no. |
| [0] | Stereo | R | 1 | Stereo stream support: 1 = yes (stereo) 0 = no (mono). |

6.26.2. *ADC1Mux ConLst*

| | Verb ID | Payload | Response |
|-----|---------|---------|---------------------|
| Get | F00 | 0E | See bitfield table. |

6.26.2.1. *ADC1Mux ConLst*

| Bit | Bitfield Name | RW | Reset | Description |
|---------|---------------|----|--------|--|
| [31..8] | Rsvd | R | 000000 | Reserved. |
| [7] | LForm | R | 0 | Connection list format: 1 = long-form (15-bit) NID entries 0 = short-form (7-bit) NID entries. |
| [6..0] | ConL | R | 04 | Number of NID entries in connection list. |

6.26.3. *ADC1Mux ConLstEntry0*

| | Verb ID | Payload | Response |
|-----|---------|---------|---------------------|
| Get | F02 | 00 | See bitfield table. |

6.26.3.1. *ADC1Mux ConLstEntry0*

| Bit | Bitfield Name | RW | Reset | Description |
|----------|---------------|----|-------|---|
| [31..24] | ConL3 | R | 00 | Unused list entry |
| [23..16] | ConL2 | R | 1D | Mixer Summing widget (0x1D) |
| [15] | ConL1Range | R | 1 | 1 = ConL0..ConL1 defines a range of selectable inputs |
| [14..8] | ConL1 | R | 14 | DMic1 Pin widget (0x14) |
| [7..0] | ConL0 | R | 0A | Port A Pin widget (0x0A) |

6.26.4. *ADC1Mux ConSelectCtrl*

| | Verb ID | Payload | Response |
|-----|---------|---------|---------------------|
| Get | F01 | 00 | See bitfield table. |

6.26.4.1. *ADC1Mux ConSelectCtrl*

| Bit | Bitfield Name | RW | Reset | Description |
|---------|---------------|----|----------|----------------------------------|
| [31..2] | Rsvd | R | 00000000 | Reserved. |
| [1..0] | Index | RW | 0 | Connection select control index. |

6.26.5. *ADC1Mux LR*

| | Verb ID | Payload | Response |
|-----|---------|---------|---------------------|
| Get | F0C | 00 | See bitfield table. |

6.26.5.1. *ADC1Mux LR*

| Bit | Bitfield Name | RW | Reset | Description |
|---------|---------------|----|----------|--|
| [31..3] | Rsvd2 | R | 00000000 | Reserved. |
| [2] | SwapEn | RW | 0 | Swap enable: 1 = L/R swap enabled 0 = L/R swap disabled. |
| [1..0] | Rsvd1 | R | 0 | Reserved. |

6.26.6. *ADC1Mux OutAmpCap*

| | Verb ID | Payload | Response |
|-----|---------|---------|---------------------|
| Get | F00 | 12 | See bitfield table. |

6.26.6.1. *ADC1Mux OutAmpCap*

| Bit | Bitfield Name | RW | Reset | Description |
|----------|---------------|----|-------|---|
| [31] | Mute | R | 1 | Mute support: 1 = yes 0 = no. |
| [30.:23] | Rsvd3 | R | 00 | Reserved. |
| [22.:16] | StepSize | R | 05 | Size of each step in the gain range: 0 to 127 = .25dB to 32dB in .25dB steps. |
| [15] | Rsvd2 | R | 0 | Reserved. |
| [14.:8] | NumSteps | R | 0F | Number of gains steps (number of possible settings - 1). |
| [7] | Rsvd1 | R | 0 | Reserved. |
| [6.:0] | Offset | R | 00 | Indicates which step is 0dB |

6.26.7. *ADC1Mux OutAmpLeft*

| | Verb ID | Payload | Response |
|-----|---------|---------|---------------------|
| Get | BA0 | 00 | See bitfield table. |

6.26.7.1. *ADC1Mux OutAmpLeft*

| Bit | Bitfield Name | RW | Reset | Description |
|---------|---------------|----|--------|---|
| [31.:8] | Rsvd2 | R | 000000 | Reserved. |
| [7] | Mute | RW | 1 | Amp mute: 1 = muted 0 = not muted. |
| [6.:4] | Rsvd1 | R | 0 | Reserved. |
| [3.:0] | Gain | RW | 0 | Amp gain step number (see OutAmpCap parameter pertaining to this widget). |

6.26.8. ADC1Mux OutAmpRight

| | Verb ID | Payload | Response |
|-----|---------|---------|---------------------|
| Get | B80 | 00 | See bitfield table. |

6.26.8.1. ADC1Mux OutAmpRight

| Bit | Bitfield Name | RW | Reset | Description |
|---------|---------------|----|--------|--|
| [31..8] | Rsvd2 | R | 000000 | Reserved. |
| [7] | Mute | RW | 1 | Amp mute: 1 = muted 0 = not muted. |
| [6..4] | Rsvd1 | R | 0 | Reserved. |
| [3..0] | Gain | RW | 0 | Amp gain step number (see OutAmp-Cap parameter pertaining to this widget). |

6.27. Dig0Pin Node (NID = 22)**6.27.1. Dig0Pin WCap**

| | Verb ID | Payload | Response |
|-----|---------|---------|---------------------|
| Get | F00 | 09 | See bitfield table. |

6.27.1.1. Dig0Pin WCap

| Bit | Bitfield Name | RW | Reset | Description |
|----------|---------------|----|-------|---|
| [31..24] | Rsvd2 | R | 00 | Reserved. |
| [23..20] | Type | R | 4 | Widget type: 0h = Out Converter; 1h = In Converter; 2h = Summing (Mixer); 3h = Selector (Mux); 4h = Pin Complex; 5h = Power; 6h = Volume Knob; 7h = Beep Generator; 8h-Eh = Reserved; Fh = Vendor Defined |

6.27.1.1. *Dig0Pin WCap*

| Bit | Bitfield Name | RW | Reset | Description |
|----------|---------------|----|-------|---|
| [19.:16] | Delay | R | 0 | Number of sample delays through wid- get. |
| [15.:12] | Rsvd1 | R | 0 | Reserved. |
| [11] | SwapCap | R | 0 | Left/right swap support: 1 = yes 0 = no. |
| [10] | PwrCntrl | R | 0 | Power state support: 1 = yes 0 = no. |
| [9] | Dig | R | 1 | Digital stream support: 1 = yes (digital) 0 = no (analog). |
| [8] | ConnList | R | 1 | Connection list present: 1 = yes 0 = no. |
| [7] | UnSolCap | R | 0 | Unsolicited response support: 1 = yes 0 = no. |
| [6] | ProcWidget | R | 0 | Processing state support: 1 = yes 0 = no. |
| [5] | Stripe | R | 0 | Striping support: 1 = yes 0 = no. |
| [4] | FormatOvrd | R | 0 | Stream format override: 1 = yes 0 = no. |
| [3] | AmpParOvrd | R | 0 | Amplifier capabilities override: 1 = yes no. |
| [2] | OutAmpPrsnt | R | 0 | Output amp present: 1 = yes 0 = no. |
| [1] | InAmpPrsnt | R | 0 | Input amp present: 1 = yes 0 = no. |
| [0] | Stereo | R | 1 | Stereo stream support: 1 = yes (stereo) 0 = no (mono). |

6.27.2. *Dig0Pin PinCap*

| | Verb ID | Payload | Response |
|-----|---------|---------|---------------------|
| Get | F00 | 0C | See bitfield table. |

6.27.2.1. *Dig0Pin PinCap*

| Bit | Bitfield Name | RW | Reset | Description |
|----------|---------------|----|-------|--|
| [31.:17] | Rsvd2 | R | 0000 | Reserved. |
| [16] | EapdCap | R | 0 | EAPD support: 1 = yes 0 = no. |
| [15.:8] | VrefCntrl | R | 00 | Vref support: bit 7 = Reserved; bit 6 = Reserved; bit 5 = 100% support (1 = yes 0 = no); bit 4 = 80% support (1 = yes 0 = no); bit 3 = Reserved; bit 2 = GND support (1 = yes 0 = no); bit 1 = 50% support (1 = yes 0 = no); bit 0 = Hi-Z support (1 = yes 0 = no) |
| [7] | Rsvd1 | R | 0 | Reserved. |
| [6] | BalancedIO | R | 0 | Balanced I/O support: 1 = yes 0 = no. |
| [5] | InCap | R | 0 | Input support: 1 = yes 0 = no. |
| [4] | OutCap | R | 1 | Output support: 1 = yes 0 = no. |
| [3] | HdphDrvCap | R | 0 | Headphone amp present: 1 = yes 0 = no. |
| [2] | PresDtctCap | R | 0 | Presence detection support: 1 = yes 0 = no. |
| [1] | TrigRqd | R | 0 | Trigger required for impedance sense: 1 = yes 0 = no. |
| [0] | ImpSenseCap | R | 0 | Impedance sense support: 1 = yes 0 = no. |

6.27.3. *Dig0Pin ConLst*

| | Verb ID | Payload | Response |
|-----|---------|---------|---------------------|
| Get | F00 | 0E | See bitfield table. |

6.27.3.1. *Dig0Pin ConLst*

| Bit | Bitfield Name | RW | Reset | Description |
|---------|---------------|----|--------|--|
| [31..8] | Rsvd | R | 000000 | Reserved. |
| [7] | LForm | R | 0 | Connection list format: 1 = long-form (15-bit) NID entries 0 = short-form (7-bit) NID entries. |
| [6..0] | ConL | R | 03 | Number of NID entries in connection list. |

6.27.4. *Dig0Pin ConLstEntry0*

| | Verb ID | Payload | Response |
|-----|---------|---------|---------------------|
| Get | F02 | 00 | See bitfield table. |

6.27.4.1. *Dig0Pin ConLstEntry0*

| Bit | Bitfield Name | RW | Reset | Description |
|----------|---------------|----|-------|-----------------------------------|
| [31..24] | ConL3 | R | 00 | Unused list entry. |
| [23..16] | ConL2 | R | 21 | ADC1Mux Summing widget (0x21) |
| [15..8] | ConL1 | R | 20 | ADC0Mux Summing widget (0x20) |
| [7..0] | ConL0 | R | 25 | SPDIFOut0 Converter widget (0x25) |

6.27.5. *Dig0Pin ConSelectCtrl*

| | Verb ID | Payload | Response |
|-----|---------|---------|---------------------|
| Get | F01 | 00 | See bitfield table. |

6.27.5.1. *Dig0Pin ConSelectCtrl*

| Bit | Bitfield Name | RW | Reset | Description |
|---------|---------------|----|----------|----------------------------------|
| [31..2] | Rsvd | R | 00000000 | Reserved. |
| [1..0] | Index | RW | 0 | Connection select control index. |

6.27.6. *Dig0Pin PinWCntrl*

| | Verb ID | Payload | Response |
|-----|---------|---------|---------------------|
| Get | F07 | 00 | See bitfield table. |

6.27.6.1. *Dig0Pin PinWCntrl*

| Bit | Bitfield Name | RW | Reset | Description |
|---------|---------------|----|----------|---|
| [31..7] | Rsvd2 | R | 00000000 | Reserved. |
| [6] | OutEn | RW | 0 | Output enable: 1 = enabled 0 = disabled. |
| [5..0] | Rsvd1 | R | 00 | Reserved. |

6.27.7. *Dig0Pin ConfigDefault*

| | Verb ID | Payload | Response |
|-----|---------|---------|---------------------|
| Get | F1C | 00 | See bitfield table. |

6.27.7.1. *Dig0Pin ConfigDefault*

| Bit | Bitfield Name | RW | Reset | Description |
|----------|------------------|----|-------|--|
| [31.:30] | PortConnectivity | RW | 0 | Port connectivity: 0h = Port complex is connected to a jack; 1h = No physical connection for port; 2h = Fixed function device is attached; 3h = Both jack and internal device attached (info in all other fields refers to integrated device any presence detection refers to jack) |
| [29.:24] | Location | RW | 1 | Location. Bits [5..4]: 0h = External on primary chassis; 1h = Internal; 2h = Separate chassis; 3h = Other. Bits [3..0]: 0h = N/A; 1h = Rear; 2h = Front; 3h = Left; 4h = Right; 5h = Top; 6h = Bottom; 7h-9h = Special; Ah-Fh = Reserved |
| [23.:20] | Device | RW | 4 | Default device: 0h = Line out; 1h = Speaker; 2h = HP out; 3h = CD; 4h = SPDIF Out; 5h = Digital other out; 6h = Modem line side; 7h = Modem handset side; 8h = Line in; 9h = Aux; Ah = Mic in; Bh = Telephony; Ch = SPDIF In; Dh = Digital other in; Eh = Reserved; Fh = Other |
| [19.:16] | ConnectionType | RW | 5 | Connection type: 0h = Unknown; 1h = 1/8" stereo/mono; 2h = 1/4" stereo/mono; 3h = ATAPI internal; 4h = RCA; 5h = Optical; 6h = Other digital; 7h = Other analog; 8h = Multichannel analog (DIN); 9h = XLR/Professional; Ah = RJ-11 (modem); Bh = Combination; Ch-Eh = Reserved; Fh = Other |
| [15.:12] | Color | RW | 1 | Color: 0h = Unknown; 1h = Black; 2h = Grey; 3h = Blue; 4h = Green; 5h = Red; 6h = Orange; 7h = Yellow; 8h = Purple; 9h = Pink; Ah-Dh = Reserved; Eh = White; Fh = Other |
| [11.:8] | Misc | RW | 0 | Miscellaneous: Bits [3..1] = Reserved; Bit 0 = Jack detect override |
| [7.:4] | Association | RW | 5 | Default association. |
| [3.:0] | Sequence | RW | 0 | Sequence. |

6.28. Dig1Pin Node (NID = 23)

6.28.1. Dig1Pin WCap

| | Verb ID | Payload | Response |
|-----|---------|---------|---------------------|
| Get | F00 | 09 | See bitfield table. |

6.28.1.1. Dig1Pin WCap

| Bit | Bitfield Name | RW | Reset | Description |
|----------|---------------|----|-------|---|
| [31.:24] | Rsvd2 | R | 00 | Reserved. |
| [23.:20] | Type | R | 4 | Widget type: 0h = Out Converter; 1h = In Converter; 2h = Summing (Mixer); 3h = Selector (Mux); 4h = Pin Complex; 5h = Power; 6h = Volume Knob; 7h = Beep Generator; 8h-Eh = Reserved; Fh = Vendor Defined |
| [19.:16] | Delay | R | 0 | Number of sample delays through widget. |
| [15.:12] | Rsvd1 | R | 0 | Reserved. |
| [11] | SwapCap | R | 0 | Left/right swap support: 1 = yes 0 = no. |
| [10] | PwrCntrl | R | 0 | Power state support: 1 = yes 0 = no. |
| [9] | Dig | R | 1 | Digital stream support: 1 = yes (digital) 0 = no (analog). |
| [8] | ConnList | R | 1 | Connection list present: 1 = yes 0 = no. |
| [7] | UnSolCap | R | 0 | Unsolicited response support: 1 = yes 0 = no. |
| [6] | ProcWidget | R | 0 | Processing state support: 1 = yes 0 = no. |
| [5] | Stripe | R | 0 | Striping support: 1 = yes 0 = no. |
| [4] | FormatOvrd | R | 0 | Stream format override: 1 = yes 0 = no. |
| [3] | AmpParOvrd | R | 0 | Amplifier capabilities override: 1 = yes no. |
| [2] | OutAmpPrsnt | R | 0 | Output amp present: 1 = yes 0 = no. |

6.28.1.1. *Dig1Pin WCap*

| Bit | Bitfield Name | RW | Reset | Description |
|-----|---------------|----|-------|---|
| [1] | InAmpPrsnt | R | 0 | Input amp present: 1 = yes 0 = no. |
| [0] | Stereo | R | 1 | Stereo stream support: 1 = yes (stereo) 0 = no (mono). |

6.28.2. *Dig1Pin PinCap*

| | Verb ID | Payload | Response |
|-----|---------|---------|---------------------|
| Get | F00 | 0C | See bitfield table. |

6.28.2.1. *Dig1Pin PinCap*

| Bit | Bitfield Name | RW | Reset | Description |
|----------|---------------|----|-------|--|
| [31.:17] | Rsvd2 | R | 0000 | Reserved. |
| [16] | EapdCap | R | 0 | EAPD support: 1 = yes 0 = no. |
| [15.:8] | VrefCntrl | R | 00 | Vref support: bit 7 = Reserved; bit 6 = Reserved; bit 5 = 100% support (1 = yes 0 = no); bit 4 = 80% support (1 = yes 0 = no); bit 3 = Reserved; bit 2 = GND support (1 = yes 0 = no); bit 1 = 50% support (1 = yes 0 = no); bit 0 = Hi-Z support (1 = yes 0 = no) |
| [7] | Rsvd1 | R | 0 | Reserved. |
| [6] | BalancedIO | R | 0 | Balanced I/O support: 1 = yes 0 = no. |
| [5] | InCap | R | 0 | Input support: 1 = yes 0 = no. |
| [4] | OutCap | R | 1 | Output support: 1 = yes 0 = no. |
| [3] | HdphDrvCap | R | 0 | Headphone amp present: 1 = yes 0 = no. |
| [2] | PresDtctCap | R | 0 | Presence detection support: 1 = yes 0 = no. |

6.28.2.1. *Dig1Pin PinCap*

| Bit | Bitfield Name | RW | Reset | Description |
|-----|---------------|----|-------|--|
| [1] | TrigRqd | R | 0 | Trigger required for impedance sense: 1 = yes 0 = no. |
| [0] | ImpSenseCap | R | 0 | Impedance sense support: 1 = yes 0 = no. |

6.28.3. *Dig1Pin ConLst*

| | Verb ID | Payload | Response |
|-----|---------|---------|---------------------|
| Get | F00 | 0E | See bitfield table. |

6.28.3.1. *Dig1Pin ConLst*

| Bit | Bitfield Name | RW | Reset | Description |
|---------|---------------|----|--------|--|
| [31..8] | Rsvd | R | 000000 | Reserved. |
| [7] | LForm | R | 0 | Connection list format: 1 = long-form (15-bit) NID entries 0 = short-form (7-bit) NID entries. |
| [6..0] | ConL | R | 03 | Number of NID entries in connection list. |

6.28.4. *Dig1Pin ConLstEntry0*

| | Verb ID | Payload | Response |
|-----|---------|---------|---------------------|
| Get | F02 | 00 | See bitfield table. |

6.28.4.1. *Dig1Pin ConLstEntry0*

| Bit | Bitfield Name | RW | Reset | Description |
|----------|---------------|----|-------|-----------------------------------|
| [31.:24] | ConL3 | R | 00 | Unused list entry. |
| [23.:16] | ConL2 | R | 21 | ADC1Mux Summing widget (0x21) |
| [15.:8] | ConL1 | R | 20 | ADC0Mux Summing widget (0x20) |
| [7.:0] | ConL0 | R | 26 | SPDIFOut1 Converter widget (0x26) |

6.28.5. *Dig1Pin ConSelectCtrl*

| | Verb ID | Payload | Response |
|-----|---------|---------|---------------------|
| Get | F01 | 00 | See bitfield table. |

6.28.5.1. *Dig1Pin ConSelectCtrl*

| Bit | Bitfield Name | RW | Reset | Description |
|---------|---------------|----|----------|----------------------------------|
| [31.:2] | Rsvd | R | 00000000 | Reserved. |
| [1.:0] | Index | RW | 0 | Connection select control index. |

6.28.6. *Dig1Pin PinWCntrl*

| | Verb ID | Payload | Response |
|-----|---------|---------|---------------------|
| Get | F07 | 00 | See bitfield table. |

6.28.6.1. *Dig1Pin PinWCntrl*

| Bit | Bitfield Name | RW | Reset | Description |
|---------|---------------|----|---------|---|
| [31..7] | Rsvd2 | R | 0000000 | Reserved. |
| [6] | OutEn | RW | 0 | Output enable: 1 = enabled 0 = disabled. |
| [5..0] | Rsvd1 | R | 00 | Reserved. |

6.28.7. *Dig1Pin ConfigDefault*

| | Verb ID | Payload | Response |
|-----|---------|---------|---------------------|
| Get | F1C | 00 | See bitfield table. |

6.28.7.1. *Dig1Pin ConfigDefault*

| Bit | Bitfield Name | RW | Reset | Description |
|----------|------------------|----|-------|---|
| [31..30] | PortConnectivity | RW | 2 | Port connectivity: 0h = Port complex is connected to a jack; 1h = No physical connection for port; 2h = Fixed function device is attached; 3h = Both jack and internal device attached (info in all other fields refers to integrated device any presence detection refers to jack) |
| [29..24] | Location | RW | 18 | Location. Bits [5..4]: 0h = External on primary chassis; 1h = Internal; 2h = Separate chassis; 3h = Other. Bits [3..0]: 0h = N/A; 1h = Rear; 2h = Front; 3h = Left; 4h = Right; 5h = Top; 6h = Bottom; 7h-9h = Special; Ah-Fh = Reserved |

6.28.7.1. *Dig1Pin ConfigDefault*

| Bit | Bitfield Name | RW | Reset | Description |
|----------|----------------|----|-------|--|
| [23.:20] | Device | RW | 5 | Default device: 0h = Line out; 1h = Speaker; 2h = HP out; 3h = CD; 4h = SPDIF Out; 5h = Digital other out; 6h = Modem line side; 7h = Modem handset side; 8h = Line in; 9h = Aux; Ah = Mic in; Bh = Telephony; Ch = SPDIF In; Dh = Digital other in; Eh = Reserved; Fh = Other |
| [19.:16] | ConnectionType | RW | 6 | Connection type: 0h = Unknown; 1h = 1/8" stereo/mono; 2h = 1/4" stereo/mono; 3h = ATAPI internal; 4h = RCA; 5h = Optical; 6h = Other digital; 7h = Other analog; 8h = Multichannel analog (DIN); 9h = XLR/Professional; Ah = RJ-11 (modem); Bh = Combination; Ch-Eh = Reserved; Fh = Other |
| [15.:12] | Color | RW | 0 | Color: 0h = Unknown; 1h = Black; 2h = Grey; 3h = Blue; 4h = Green; 5h = Red; 6h = Orange; 7h = Yellow; 8h = Purple; 9h = Pink; Ah-Dh = Reserved; Eh = White; Fh = Other |
| [11.:8] | Misc | RW | 0 | Miscellaneous: Bits [3..1] = Reserved; Bit 0 = Jack detect override |
| [7.:4] | Association | RW | 6 | Default association. |
| [3.:0] | Sequence | RW | 0 | Sequence. |

6.29. Dig2Pin Node (NID = 24)

6.29.1. *Dig2Pin WCap*

| | Verb ID | Payload | Response |
|-----|---------|---------|---------------------|
| Get | F00 | 09 | See bitfield table. |

6.29.1.1. *Dig2Pin WCap*

| Bit | Bitfield Name | RW | Reset | Description |
|----------|---------------|----|-------|---|
| [31.:24] | Rsvd2 | R | 00 | Reserved. |
| [23.:20] | Type | R | 4 | Widget type: 0h = Out Converter; 1h = In Converter; 2h = Summing (Mixer); 3h = Selector (Mux); 4h = Pin Complex; 5h = Power; 6h = Volume Knob; 7h = Beep Generator; 8h-Eh = Reserved; Fh = Vendor Defined |
| [19.:16] | Delay | R | 0 | Number of sample delays through widget. |
| [15.:12] | Rsvd1 | R | 0 | Reserved. |
| [11] | SwapCap | R | 0 | Left/right swap support: 1 = yes 0 = no. |
| [10] | PwrCntrl | R | 0 | Power state support: 1 = yes 0 = no. |
| [9] | Dig | R | 1 | Digital stream support: 1 = yes (digital) 0 = no (analog). |
| [8] | ConnList | R | 0 | Connection list present: 1 = yes 0 = no. |
| [7] | UnSolCap | R | 0 | Unsolicited response support: 1 = yes 0 = no. |
| [6] | ProcWidget | R | 0 | Processing state support: 1 = yes 0 = no. |
| [5] | Stripe | R | 0 | Striping support: 1 = yes 0 = no. |
| [4] | FormatOvrd | R | 0 | Stream format override: 1 = yes 0 = no. |
| [3] | AmpParOvrd | R | 0 | Amplifier capabilities override: 1 = yes no. |
| [2] | OutAmpPrsnt | R | 0 | Output amp present: 1 = yes 0 = no. |
| [1] | InAmpPrsnt | R | 0 | Input amp present: 1 = yes 0 = no. |
| [0] | Stereo | R | 1 | Stereo stream support: 1 = yes (stereo) 0 = no (mono). |

6.29.2. Dig2Pin PinCap

| | Verb ID | Payload | Response |
|-----|---------|---------|---------------------|
| Get | F00 | 0C | See bitfield table. |

6.29.2.1. Dig2Pin PinCap

| Bit | Bitfield Name | RW | Reset | Description |
|----------|---------------|----|-------|--|
| [31.:17] | Rsvd2 | R | 0000 | Reserved. |
| [16] | EapdCap | R | 0 | EAPD support: 1 = yes 0 = no. |
| [15.:8] | VrefCntrl | R | 00 | Vref support: bit 7 = Reserved; bit 6 = Reserved; bit 5 = 100% support (1 = yes 0 = no); bit 4 = 80% support (1 = yes 0 = no); bit 3 = Reserved; bit 2 = GND support (1 = yes 0 = no); bit 1 = 50% support (1 = yes 0 = no); bit 0 = Hi-Z support (1 = yes 0 = no) |
| [7] | Rsvd1 | R | 0 | Reserved. |
| [6] | BalancedIO | R | 0 | Balanced I/O support: 1 = yes 0 = no. |
| [5] | InCap | R | 1 | Input support: 1 = yes 0 = no. |
| [4] | OutCap | R | 0 | Output support: 1 = yes 0 = no. |
| [3] | HdphDrvCap | R | 0 | Headphone amp present: 1 = yes 0 = no. |
| [2] | PresDtctCap | R | 1 | Presence detection support: 1 = yes 0 = no. |
| [1] | TrigRqd | R | 0 | Trigger required for impedance sense: 1 = yes 0 = no. |
| [0] | ImpSenseCap | R | 0 | Impedance sense support: 1 = yes 0 = no. |

6.29.3. Dig2Pin PinWCntrl

| | Verb ID | Payload | Response |
|-----|---------|---------|---------------------|
| Get | F07 | 00 | See bitfield table. |

6.29.3.1. Dig2Pin PinWCntrl

| Bit | Bitfield Name | RW | Reset | Description |
|---------|---------------|----|---------|--|
| [31.:7] | Rsvd2 | R | 0000000 | Reserved. |
| [6] | 1nEn | RW | 0 | input enable: 1 = enabled 0 = disabled. |
| [5.:0] | Rsvd1 | R | 00 | Reserved. |

6.29.4. Dig2Pin UnsolResp

| | Verb ID | Payload | Response |
|-----|---------|---------|---------------------|
| Get | F08 | 00 | See bitfield table. |

6.29.4.1. Dig2Pin UnsolResp

| Bit | Bitfield Name | RW | Reset | Description |
|---------|---------------|----|--------|--|
| [31.:8] | Rsvd2 | R | 000000 | Reserved. |
| [7] | En | RW | 0 | Unsolicited response enable: 1 = enabled, 0 = disabled. |
| [6] | Rsvd1 | R | 0 | Reserved. |
| [5.:0] | Tag | RW | 00 | Software programmable field returned in top six bits (31:26) of every Unsolicited Response generated by this node. |

6.29.5. Dig2Pin ChSense

| | Verb ID | Payload | Response |
|-----|---------|---------|---------------------|
| Get | F09 | 00 | See bitfield table. |

6.29.5.1. Dig2Pin ChSense

| Bit | Bitfield Name | RW | Reset | Description |
|---------|---------------|----|-------|---|
| [31] | PresDtct | R | 0 | Presence detection indicator: 1 = presence detected; 0 = presence not detected. |
| [30.:0] | Rsvd | R | 0 | Reserved. |

6.29.6. Dig2Pin PwrState

| | Verb ID | Payload | Response |
|-----|---------|---------|---------------------|
| Get | F05 | 00 | See bitfield table. |

6.29.6.1. Dig2Pin PwrState

| Bit | Bitfield Name | RW | Reset | Description |
|---------|---------------|----|---------|--|
| [31.:6] | Rsvd2 | R | 0000000 | Reserved. |
| [5.:4] | Act | R | 3 | Actual power state of this widget. |
| [3.:2] | Rsvd1 | R | 0 | Reserved. |
| [1.:0] | Set | RW | 3 | Current power state setting for this widget, used for EAPD control in this case: 0h-1h = Pin drives the value of the EAPD control bit 2h-3h = Pin tri-stated |

6.29.7. Dig2Pin EAPD

| | Verb ID | Payload | Response |
|-----|---------|---------|---------------------|
| Get | F0C | 00 | See bitfield table. |

6.29.7.1. Dig2Pin EAPD

| Bit | Bitfield Name | RW | Reset | Description |
|---------|---------------|----|----------|--|
| [31..2] | Rsvd2 | R | 00000000 | Reserved. |
| [1] | Control | RW | 0 | EAPD value reflected on the EAPD pin: 0 = Power down external amplifier; 1 = Power up external amplifier |
| [0] | Rsvd1 | R | 0 | Reserved. |

6.29.8. Dig2Pin ConfigDefault

| | Verb ID | Payload | Response |
|-----|---------|---------|---------------------|
| Get | F1C | 00 | See bitfield table. |

6.29.8.1. *Dig2Pin ConfigDefault*

| Bit | Bitfield Name | RW | Reset | Description |
|----------|------------------|----|-------|--|
| [31.:30] | PortConnectivity | RW | 0 | Port connectivity: 0h = Port complex is connected to a jack; 1h = No physical connection for port; 2h = Fixed function device is attached; 3h = Both jack and internal device attached (info in all other fields refers to integrated device any presence detection refers to jack) |
| [29.:24] | Location | RW | 01 | Location. Bits [5..4]: 0h = External on primary chassis; 1h = Internal; 2h = Separate chassis; 3h = Other. Bits [3..0]: 0h = N/A; 1h = Rear; 2h = Front; 3h = Left; 4h = Right; 5h = Top; 6h = Bottom; 7h-9h = Special; Ah-Fh = Reserved |
| [23.:20] | Device | RW | C | Default device: 0h = Line out; 1h = Speaker; 2h = HP out; 3h = CD; 4h = SPDIF Out; 5h = Digital other out; 6h = Modem line side; 7h = Modem handset side; 8h = Line in; 9h = Aux; Ah = Mic in; Bh = Telephony; Ch = SPDIF In; Dh = Digital other in; Eh = Reserved; Fh = Other |
| [19.:16] | ConnectionType | RW | 5 | Connection type: 0h = Unknown; 1h = 1/8" stereo/mono; 2h = 1/4" stereo/mono; 3h = ATAPI internal; 4h = RCA; 5h = Optical; 6h = Other digital; 7h = Other analog; 8h = Multichannel analog (DIN); 9h = XLR/Professional; Ah = RJ-11 (modem); Bh = Combination; Ch-Eh = Reserved; Fh = Other |
| [15.:12] | Color | RW | 2 | Color: 0h = Unknown; 1h = Black; 2h = Grey; 3h = Blue; 4h = Green; 5h = Red; 6h = Orange; 7h = Yellow; 8h = Purple; 9h = Pink; Ah-Dh = Reserved; Eh = White; Fh = Other |
| [11.:8] | Misc | RW | 0 | Miscellaneous: Bits [3..1] = Reserved; Bit 0 = Jack detect override |
| [7.:4] | Association | RW | 8 | Default association. |
| [3.:0] | Sequence | RW | 0 | Sequence. |

6.30. SPDIFOut0 Node (NID = 25)

6.30.1. SPDIFOut0 WCap

| | Verb ID | Payload | Response |
|-----|---------|---------|---------------------|
| Get | F00 | 09 | See bitfield table. |

6.30.1.1. SPDIFOut0 WCap

| Bit | Bitfield Name | RW | Reset | Description |
|----------|---------------|----|-------|---|
| [31.:24] | Rsvd2 | R | 00 | Reserved. |
| [23.:20] | Type | R | 0 | Widget type: 0h = Out Converter; 1h = In Converter; 2h = Summing (Mixer); 3h = Selector (Mux); 4h = Pin Complex; 5h = Power; 6h = Volume Knob; 7h = Beep Generator; 8h-Eh = Reserved; Fh = Vendor Defined |
| [19.:16] | Delay | R | 4 | Number of sample delays through widget. |
| [15.:12] | Rsvd1 | R | 0 | Reserved. |
| [11] | SwapCap | R | 0 | Left/right swap support: 1 = yes 0 = no. |
| [10] | PwrCntrl | R | 0 | Power state support: 1 = yes 0 = no. |
| [9] | Dig | R | 1 | Digital stream support: 1 = yes (digital) 0 = no (analog). |
| [8] | ConnList | R | 0 | Connection list present: 1 = yes 0 = no. |
| [7] | UnSolCap | R | 0 | Unsolicited response support: 1 = yes 0 = no. |
| [6] | ProcWidget | R | 0 | Processing state support: 1 = yes 0 = no. |
| [5] | Stripe | R | 0 | Striping support: 1 = yes 0 = no. |
| [4] | FormatOvrd | R | 1 | Stream format override: 1 = yes 0 = no. |
| [3] | AmpParOvrd | R | 1 | Amplifier capabilities override: 1 = yes no. |
| [2] | OutAmpPrsnt | R | 1 | Output amp present: 1 = yes 0 = no. |

6.30.1.1. *SPDIFOut0 WCap*

| Bit | Bitfield Name | RW | Reset | Description |
|-----|---------------|----|-------|---|
| [1] | InAmpPrsnt | R | 0 | Input amp present: 1 = yes 0 = no. |
| [0] | Stereo | R | 1 | Stereo stream support: 1 = yes (stereo) 0 = no (mono). |

6.30.2. *SPDIFOut0 PCMCap*

| | Verb ID | Payload | Response |
|-----|---------|---------|---------------------|
| Get | F00 | 0A | See bitfield table. |

6.30.2.1. *SPDIFOut0 PCMCap*

| Bit | Bitfield Name | RW | Reset | Description |
|----------|---------------|----|-------|--|
| [31.:21] | Rsvd2 | R | 000 | Reserved. |
| [20] | B32 | R | 0 | 32 bit audio format support: 1 = yes, 0 = no. |
| [19] | B24 | R | 1 | 24 bit audio format support: 1 = yes, 0 = no. |
| [18] | B20 | R | 1 | 20 bit audio format support: 1 = yes, 0 = no. |
| [17] | B16 | R | 1 | 16 bit audio format support: 1 = yes, 0 = no. |
| [16] | B8 | R | 0 | 8 bit audio format support: 1 = yes, 0 = no. |
| [15.:12] | Rsvd1 | R | 0 | Reserved. |
| [11] | R12 | R | 0 | 384kHz rate support: 1 = yes, 0 = no. |
| [10] | R11 | R | 1 | 192kHz rate support: 1 = yes, 0 = no. |
| [9] | R10 | R | 1 | 176.4kHz rate support: 1 = yes, 0 = no. |
| [8] | R9 | R | 1 | 96kHz rate support: 1 = yes, 0 = no. |
| [7] | R8 | R | 1 | 88.2kHz rate support: 1 = yes, 0 = no. |

6.30.2.1. *SPDIFOut0 PCMCap*

| Bit | Bitfield Name | RW | Reset | Description |
|-----|---------------|----|-------|--|
| [6] | R7 | R | 1 | 48kHz rate support: 1 = yes, 0 = no. |
| [5] | R6 | R | 1 | 44.1kHz rate support: 1 = yes, 0 = no. |
| [4] | R5 | R | 0 | 32kHz rate support: 1 = yes, 0 = no. |
| [3] | R4 | R | 0 | 22.05kHz rate support: 1 = yes, 0 = no. |
| [2] | R3 | R | 0 | 16kHz rate support: 1 = yes, 0 = no. |
| [1] | R2 | R | 0 | 11.025kHz rate support: 1 = yes, 0 = no. |
| [0] | R1 | R | 0 | 8kHz rate support: 1 = yes, 0 = no. |

6.30.3. *SPDIFOut0 StreamCap*

| | Verb ID | Payload | Response |
|-----|---------|---------|---------------------|
| Get | F00 | 0B | See bitfield table. |

6.30.3.1. *SPDIFOut0 StreamCap*

| Bit | Bitfield Name | RW | Reset | Description |
|---------|---------------|----|----------|---|
| [31..3] | Rsvd | R | 00000000 | Reserved. |
| [2] | AC3 | R | 1 | AC-3 formatted data support: 1 = yes, 0 = no. |
| [1] | Float32 | R | 0 | Float32 formatted data support: 1 = yes, 0 = no. |
| [0] | PCM | R | 1 | PCM-formatted data support: 1 = yes, 0 = no. |

6.30.4. SPDIFOut0 Cnvtr

| | Verb ID | Payload | Response |
|-----|---------|---------|---------------------|
| Get | A00 | 00 | See bitfield table. |

6.30.4.1. SPDIFOut0 Cnvtr

| Bit | Bitfield Name | RW | Reset | Description |
|----------|---------------|----|-------|--|
| [31.:16] | Rsvd2 | R | 0000 | Reserved. |
| [15] | FrmtNonPCM | RW | 0 | Stream type: 1 = Non-PCM, 0 = PCM. |
| [14] | FrmtSmplRate | RW | 0 | Sample base rate: 1 = 44.1kHz, 0 = 48kHz. |
| [13.:11] | SmplRateMultp | RW | 0 | Sample base rate multiple: 000b= x1 (48kHz/44.1kHz or less); 001b= x2 (96kHz/88.2kHz/32kHz); 010b= x3 (144kHz); 011b= x4 (192kHz/176.4kHz); 100b-111b Reserved |
| [10.:8] | SmplRateDiv | RW | 0 | Sample base rate divider: 000b= Divide by 1 (48kHz/44.1kHz); 001b= Divide by 2 (24kHz/20.05kHz); 010b= Divide by 3 (16kHz/32kHz); 011b= Divide by 4 (11.025kHz); 100b= Divide by 5 (9.6kHz); 101b= Divide by 6 (8kHz); 110b= Divide by 7; 111b= Divide by 8 (6kHz) |
| [7] | Rsvd1 | R | 0 | Reserved. |
| [6.:4] | BitsPerSmpl | RW | 3 | Bits per sample: 000b= 8 bits; 001b= 16 bits; 010b= 20 bits; 011b= 24 bits; 100b= 32 bits; 101b-111b= Reserved |
| [3.:0] | NmbrChan | RW | 1 | Total number of channels in the stream assigned to this converter: 0000b-1111b= 1-16 channels. |

6.30.5. SPDIFOut0 CnvtrID

| | Verb ID | Payload | Response |
|-----|---------|---------|---------------------|
| Get | F06 | 00 | See bitfield table. |

6.30.5.1. SPDIFOut0 CnvtrID

| Bit | Bitfield Name | RW | Reset | Description |
|---------|---------------|----|--------|--|
| [31..8] | Rsvd | R | 000000 | Reserved. |
| [7..4] | Strm | RW | 0 | Stream ID: 0h = Converter "off", 1h-Fh = valid IDs. |
| [3..0] | Ch | RW | 0 | Channel assignment ("Ch" and "Ch+1" assigned as a pair, for a stereo converter). |

6.30.6. SPDIFOut0 DigCnvtr

| | Verb ID | Payload | Response |
|-----|---------|---------|---------------------|
| Get | F0D | 00 | See bitfield table. |

6.30.6.1. SPDIFOut0 DigCnvtr

| Bit | Bitfield Name | RW | Reset | Description |
|----------|---------------|----|-------|----------------------|
| [31..16] | Rsvd2 | R | 0000 | Reserved. |
| [15] | Rsvd1 | R | 0 | Reserved. |
| [14..8] | CC | RW | 00 | CC: Category Code. |
| [7] | L | RW | 0 | L: Generation Level. |
| [6] | PRO | RW | 0 | PRO: Professional. |
| [5] | AUDIO | RW | 0 | /AUDIO: Non-Audio. |
| [4] | COPY | RW | 0 | COPY: Copyright. |

6.30.6.1. SPDIFOut0 DigCnvtr

| Bit | Bitfield Name | RW | Reset | Description |
|-----|---------------|----|-------|---|
| [3] | PRE | RW | 0 | PRE: Preemphasis. |
| [2] | VCFG | RW | 0 | VCFG: Validity Config. |
| [1] | V | RW | 0 | V: Validity. |
| [0] | DigEn | RW | 0 | Digital enable: 1 = converter enabled, 0 = converter disable. |

6.30.7. SPDIFOut0 OutAmpCap

| | Verb ID | Payload | Response |
|-----|---------|---------|---------------------|
| Get | F00 | 12 | See bitfield table. |

6.30.7.1. SPDIFOut0 OutAmpCap

| Bit | Bitfield Name | RW | Reset | Description |
|----------|---------------|----|-------|--|
| [31] | Mute | R | 1 | Mute support: 1 = yes, 0 = no. |
| [30.:23] | Rsvd3 | R | 00 | Reserved. |
| [22.:16] | StepSize | R | 17 | Size of each step in the gain range: 0 to 127 = .25dB to 32dB, in .25dB steps. |
| [15] | Rsvd2 | R | 0 | Reserved. |
| [14.:8] | NumSteps | R | 00 | Number of gains steps (number of possible settings - 1). |
| [7] | Rsvd1 | R | 0 | Reserved. |
| [6.:0] | Offset | R | 03 | Indicates which step is 0dB |

6.30.8. SPDIFOut0 OutAmpLeft

| | Verb ID | Payload | Response |
|-----|---------|---------|---------------------|
| Get | BA0 | 00 | See bitfield table. |

6.30.8.1. SPDIFOut0 OutAmpLeft

| Bit | Bitfield Name | RW | Reset | Description |
|---------|---------------|----|--------|-------------------------------------|
| [31..8] | Rsvd2 | R | 000000 | Reserved. |
| [7] | Mute | RW | 0 | Amp mute: 1 = muted, 0 = not muted. |
| [6..0] | Rsvd1 | R | 00 | Reserved. |

6.30.9. SPDIFOut0 OutAmpRight

| | Verb ID | Payload | Response |
|-----|---------|---------|---------------------|
| Get | B80 | 00 | See bitfield table. |

6.30.9.1. SPDIFOut0 OutAmpRight

| Bit | Bitfield Name | RW | Reset | Description |
|---------|---------------|----|--------|-------------------------------------|
| [31..8] | Rsvd2 | R | 000000 | Reserved. |
| [7] | Mute | RW | 0 | Amp mute: 1 = muted, 0 = not muted. |
| [6..0] | Rsvd1 | R | 00 | Reserved. |

6.31. SPDIFOut1 Node (NID = 26)**6.31.1. SPDIFOut1 WCap**

| | Verb ID | Payload | Response |
|-----|---------|---------|---------------------|
| Get | F00 | 09 | See bitfield table. |

6.31.1.1. SPDIFOut1 WCap

| Bit | Bitfield Name | RW | Reset | Description |
|----------|---------------|----|-------|---|
| [31.:24] | Rsvd2 | R | 00 | Reserved. |
| [23.:20] | Type | R | 0 | Widget type: 0h = Out Converter; 1h = In Converter; 2h = Summing (Mixer); 3h = Selector (Mux); 4h = Pin Complex; 5h = Power; 6h = Volume Knob; 7h = Beep Generator; 8h-Eh = Reserved; Fh = Vendor Defined |
| [19.:16] | Delay | R | 4 | Number of sample delays through widget. |
| [15.:12] | Rsvd1 | R | 0 | Reserved. |
| [11] | SwapCap | R | 0 | Left/right swap support: 1 = yes, 0 = no. |
| [10] | PwrCntrl | R | 0 | Power state support: 1 = yes, 0 = no. |
| [9] | Dig | R | 1 | Digital stream support: 1 = yes (digital), 0 = no (analog). |
| [8] | ConnList | R | 0 | Connection list present: 1 = yes, 0 = no. |
| [7] | UnSolCap | R | 0 | Unsolicited response support: 1 = yes, 0 = no. |
| [6] | ProcWidget | R | 0 | Processing state support: 1 = yes, 0 = no. |
| [5] | Stripe | R | 0 | Striping support: 1 = yes, 0 = no. |
| [4] | FormatOvrd | R | 1 | Stream format override: 1 = yes, 0 = no. |
| [3] | AmpParOvrd | R | 1 | Amplifier capabilities override: 1 = yes, no. |
| [2] | OutAmpPrsnt | R | 1 | Output amp present: 1 = yes, 0 = no. |
| [1] | InAmpPrsnt | R | 0 | Input amp present: 1 = yes, 0 = no. |
| [0] | Stereo | R | 1 | Stereo stream support: 1 = yes (stereo), 0 = no (mono). |

6.31.2. SPDIFOut1 PCMCap

| | Verb ID | Payload | Response |
|-----|---------|---------|---------------------|
| Get | F00 | 0A | See bitfield table. |

6.31.2.1. SPDIFOut1 PCMCap

| Bit | Bitfield Name | RW | Reset | Description |
|----------|---------------|----|-------|--|
| [31.:21] | Rsvd2 | R | 000 | Reserved. |
| [20] | B32 | R | 0 | 32 bit audio format support: 1 = yes, 0 = no. |
| [19] | B24 | R | 1 | 24 bit audio format support: 1 = yes, 0 = no. |
| [18] | B20 | R | 1 | 20 bit audio format support: 1 = yes, 0 = no. |
| [17] | B16 | R | 1 | 16 bit audio format support: 1 = yes, 0 = no. |
| [16] | B8 | R | 0 | 8 bit audio format support: 1 = yes, 0 = no. |
| [15.:12] | Rsvd1 | R | 0 | Reserved. |
| [11] | R12 | R | 0 | 384kHz rate support: 1 = yes, 0 = no. |
| [10] | R11 | R | 1 | 192kHz rate support: 1 = yes, 0 = no. |
| [9] | R10 | R | 1 | 176.4kHz rate support: 1 = yes, 0 = no. |
| [8] | R9 | R | 1 | 96kHz rate support: 1 = yes, 0 = no. |
| [7] | R8 | R | 1 | 88.2kHz rate support: 1 = yes, 0 = no. |
| [6] | R7 | R | 1 | 48kHz rate support: 1 = yes, 0 = no. |
| [5] | R6 | R | 1 | 44.1kHz rate support: 1 = yes, 0 = no. |
| [4] | R5 | R | 0 | 32kHz rate support: 1 = yes, 0 = no. |
| [3] | R4 | R | 0 | 22.05kHz rate support: 1 = yes, 0 = no. |
| [2] | R3 | R | 0 | 16kHz rate support: 1 = yes, 0 = no. |

6.31.2.1. *SPDIFOut1 PCMCap*

| Bit | Bitfield Name | RW | Reset | Description |
|-----|---------------|----|-------|--|
| [1] | R2 | R | 0 | 11.025kHz rate support: 1 = yes, 0 = no. |
| [0] | R1 | R | 0 | 8kHz rate support: 1 = yes, 0 = no. |

6.31.3. *SPDIFOut1 StreamCap*

| | Verb ID | Payload | Response |
|-----|---------|---------|---------------------|
| Get | F00 | 0B | See bitfield table. |

6.31.3.1. *SPDIFOut1 StreamCap*

| Bit | Bitfield Name | RW | Reset | Description |
|---------|---------------|----|----------|---|
| [31..3] | Rsvd | R | 00000000 | Reserved. |
| [2] | AC3 | R | 1 | AC-3 formatted data support: 1 = yes, 0 = no. |
| [1] | Float32 | R | 0 | Float32 formatted data support: 1 = yes, 0 = no. |
| [0] | PCM | R | 1 | PCM-formatted data support: 1 = yes, 0 = no. |

6.31.4. *SPDIFOut1 Cnvtr*

| | Verb ID | Payload | Response |
|-----|---------|---------|---------------------|
| Get | A00 | 00 | See bitfield table. |

6.31.4.1. SPDIFOut1 Cnvtr

| Bit | Bitfield Name | RW | Reset | Description |
|----------|---------------|----|-------|--|
| [31..16] | Rsvd2 | R | 0000 | Reserved. |
| [15] | FrmtNonPCM | RW | 0 | Stream type: 1 = Non-PCM, 0 = PCM. |
| [14] | FrmtSmplRate | RW | 0 | Sample base rate: 1 = 44.1kHz, 0 = 48kHz. |
| [13..11] | SmplRateMultp | RW | 0 | Sample base rate multiple: 000b= x1 (48kHz/44.1kHz or less); 001b= x2 (96kHz/88.2kHz/32kHz); 010b= x3 (144kHz); 011b= x4 (192kHz/176.4kHz); 100b-111b Reserved |
| [10..8] | SmplRateDiv | RW | 0 | Sample base rate divider: 000b= Divide by 1 (48kHz/44.1kHz); 001b= Divide by 2 (24kHz/20.05kHz); 010b= Divide by 3 (16kHz/32kHz); 011b= Divide by 4 (11.025kHz); 100b= Divide by 5 (9.6kHz); 101b= Divide by 6 (8kHz); 110b= Divide by 7; 111b= Divide by 8 (6kHz) |
| [7] | Rsvd1 | R | 0 | Reserved. |
| [6..4] | BitsPerSmpl | RW | 3 | Bits per sample: 000b= 8 bits; 001b= 16 bits; 010b= 20 bits; 011b= 24 bits; 100b= 32 bits; 101b-111b= Reserved |
| [3..0] | NmbrChan | RW | 1 | Total number of channels in the stream assigned to this converter: 0000b-1111b= 1-16 channels. |

6.31.5. SPDIFOut1 CnvtrID

| | Verb ID | Payload | Response |
|-----|---------|---------|---------------------|
| Get | F06 | 00 | See bitfield table. |

6.31.5.1. *SPDIFOut1 CnvtrID*

| Bit | Bitfield Name | RW | Reset | Description |
|---------|---------------|----|--------|--|
| [31..8] | Rsvd | R | 000000 | Reserved. |
| [7..4] | Strm | RW | 0 | Stream ID: 0h = Converter "off", 1h-Fh = valid IDs. |
| [3..0] | Ch | RW | 0 | Channel assignment ("Ch" and "Ch+1" assigned as a pair, for a stereo converter). |

6.31.6. *SPDIFOut1 DigCnvtr*

| | Verb ID | Payload | Response |
|-----|---------|---------|---------------------|
| Get | F0D | 00 | See bitfield table. |

6.31.6.1. *SPDIFOut1 DigCnvtr*

| Bit | Bitfield Name | RW | Reset | Description |
|----------|---------------|----|-------|------------------------|
| [31..16] | Rsvd2 | R | 0000 | Reserved. |
| [15] | Rsvd1 | R | 0 | Reserved. |
| [14..8] | CC | RW | 00 | CC: Category Code. |
| [7] | L | RW | 0 | L: Generation Level. |
| [6] | PRO | RW | 0 | PRO: Professional. |
| [5] | AUDIO | RW | 0 | /AUDIO: Non-Audio. |
| [4] | COPY | RW | 0 | COPY: Copyright. |
| [3] | PRE | RW | 0 | PRE: Preemphasis. |
| [2] | VCFG | RW | 0 | VCFG: Validity Config. |

6.31.6.1. *SPDIFOut1 DigCnvtr*

| Bit | Bitfield Name | RW | Reset | Description |
|-----|---------------|----|-------|---|
| [1] | V | RW | 0 | V: Validity. |
| [0] | DigEn | RW | 0 | Digital enable: 1 = converter enabled, 0 = converter disable. |

6.31.7. *SPDIFOut1 OutAmpCap*

| | Verb ID | Payload | Response |
|-----|---------|---------|---------------------|
| Get | F00 | 12 | See bitfield table. |

6.31.7.1. *SPDIFOut1 OutAmpCap*

| Bit | Bitfield Name | RW | Reset | Description |
|----------|---------------|----|-------|--|
| [31] | Mute | R | 1 | Mute support: 1 = yes, 0 = no. |
| [30.:23] | Rsvd3 | R | 00 | Reserved. |
| [22.:16] | StepSize | R | 00 | Size of each step in the gain range: 0 to 127 = .25dB to 32dB, in .25dB steps. |
| [15] | Rsvd2 | R | 0 | Reserved. |
| [14.:8] | NumSteps | R | 00 | Number of gains steps (number of possible settings - 1). |
| [7] | Rsvd1 | R | 0 | Reserved. |
| [6.:0] | Offset | R | 00 | Indicates which step is 0dB |

6.31.8. *SPDIFOut1 OutAmpLeft*

| | Verb ID | Payload | Response |
|-----|---------|---------|---------------------|
| Get | BA0 | 00 | See bitfield table. |

6.31.8.1. *SPDIFOut1 OutAmpLeft*

| Bit | Bitfield Name | RW | Reset | Description |
|---------|---------------|----|--------|-------------------------------------|
| [31..8] | Rsvd2 | R | 000000 | Reserved. |
| [7] | Mute | RW | 0 | Amp mute: 1 = muted, 0 = not muted. |
| [6..0] | Rsvd1 | R | 00 | Reserved. |

6.31.9. *SPDIFOut1 OutAmpRight*

| | Verb ID | Payload | Response |
|-----|---------|---------|---------------------|
| Get | B80 | 00 | See bitfield table. |

6.31.9.1. *SPDIFOut1 OutAmpRight*

| Bit | Bitfield Name | RW | Reset | Description |
|---------|---------------|----|--------|-------------------------------------|
| [31..8] | Rsvd2 | R | 000000 | Reserved. |
| [7] | Mute | RW | 0 | Amp mute: 1 = muted, 0 = not muted. |
| [6..0] | Rsvd1 | R | 00 | Reserved. |

6.32. SPDIFIn Node (NID = 27)

6.32.1. *SPDIFOut1 WCap*

| | Verb ID | Payload | Response |
|-----|---------|---------|---------------------|
| Get | F00 | 09 | See bitfield table. |

6.32.1.1. SPDIFInWCap

| Bit | Bitfield Name | RW | Reset | Description |
|----------|---------------|----|-------|---|
| [31.:24] | Rsvd2 | R | 00 | Reserved. |
| [23.:20] | Type | R | 1 | Widget type: 0h = Out Converter; 1h = In Converter; 2h = Summing (Mixer); 3h = Selector (Mux); 4h = Pin Complex; 5h = Power; 6h = Volume Knob; 7h = Beep Generator; 8h-Eh = Reserved; Fh = Vendor Defined |
| [19.:16] | Delay | R | 4 | Number of sample delays through widget. |
| [15.:12] | Rsvd1 | R | 0 | Reserved. |
| [11] | SwapCap | R | 0 | Left/right swap support: 1 = yes, 0 = no. |
| [10] | PwrCntrl | R | 0 | Power state support: 1 = yes, 0 = no. |
| [9] | Dig | R | 1 | Digital stream support: 1 = yes (digital), 0 = no (analog). |
| [8] | ConnList | R | 1 | Connection list present: 1 = yes, 0 = no. |
| [7] | UnSolCap | R | 0 | Unsolicited response support: 1 = yes, 0 = no. |
| [6] | ProcWidget | R | 0 | Processing state support: 1 = yes, 0 = no. |
| [5] | Stripe | R | 0 | Striping support: 1 = yes, 0 = no. |
| [4] | FormatOvrd | R | 1 | Stream format override: 1 = yes, 0 = no. |
| [3] | AmpParOvrd | R | 1 | Amplifier capabilities override: 1 = yes, no. |
| [2] | OutAmpPrsnt | R | 0 | Output amp present: 1 = yes, 0 = no. |
| [1] | InAmpPrsnt | R | 1 | Input amp present: 1 = yes, 0 = no. |
| [0] | Stereo | R | 1 | Stereo stream support: 1 = yes (stereo), 0 = no (mono). |

6.32.2. SPDIFInCnvtr

| | Verb ID | Payload | Response |
|-----|---------|---------|---------------------|
| Get | A00 | 00 | See bitfield table. |

6.32.2.1. SPFIDIn Cnvtr

| Bit | Bitfield Name | RW | Reset | Description |
|----------|---------------|----|-------|---|
| [31.:16] | Rsvd2 | R | 0000 | Reserved. |
| [15] | FrmtNonPCM | R | 0 | Stream type: 1 = Non-PCM 0 = PCM. |
| [14] | FrmtSmplRate | RW | 0 | Sample base rate: 1 = 44.1kHz 0 = 48kHz. |
| [13.:11] | SmplRateMultp | RW | 0 | Sample base rate multiple: 000b= x1 (48kHz/44.1kHz or less); 001b= x2 (96kHz/88.2kHz/32kHz); 010b= x3 (144kHz); 011b= x4 (192kHz/176.4kHz); 100b-111b Re- served |
| [10.:8] | SmplRateDiv | RW | 0 | Sample base rate divider: 000b= Divide by 1 (48kHz/44.1kHz); 001b= Divide by 2 (24kHz/20.05kHz); 010b= Divide by 3 (16kHz/32kHz); 011b= Divide by 4 (11.025kHz); 100b= Divide by 5 (9.6kHz); 101b= Divide by 6 (8kHz); 110b= Divide by 7; 111b= Divide by 8 (6kHz) |
| [7] | Rsvd1 | R | 0 | Reserved. |
| [6.:4] | BitsPerSmpl | RW | 3 | Bits per sample: 000b= 8 bits; 001b= 16 bits; 010b= 20 bits; 011b= 24 bits; 100b= 32 bits; 101b-111b= Reserved |
| [3.:0] | NmbrChan | RW | 1 | Total number of channels in the stream assigned to this converter: 0000b-1111b= 1-16 channels. |

6.32.3. SPDIFIn PCMCap

| | Verb ID | Payload | Response |
|-----|---------|---------|---------------------|
| Get | F00 | 0A | See bitfield table. |

6.32.3.1. SPDIFIn PCMCap

| Bit | Bitfield Name | RW | Reset | Description |
|----------|---------------|----|-------|--|
| [31.:21] | Rsvd2 | R | 000 | Reserved. |
| [20] | B32 | R | 0 | 32 bit audio format support: 1 = yes, 0 = no. |
| [19] | B24 | R | 1 | 24 bit audio format support: 1 = yes, 0 = no. |
| [18] | B20 | R | 1 | 20 bit audio format support: 1 = yes, 0 = no. |
| [17] | B16 | R | 1 | 16 bit audio format support: 1 = yes, 0 = no. |
| [16] | B8 | R | 0 | 8 bit audio format support: 1 = yes, 0 = no. |
| [15.:12] | Rsvd1 | R | 0 | Reserved. |
| [11] | R12 | R | 0 | 384kHz rate support: 1 = yes, 0 = no. |
| [10] | R11 | R | 0 | 192kHz rate support: 1 = yes, 0 = no. |
| [9] | R10 | R | 0 | 176.4kHz rate support: 1 = yes, 0 = no. |
| [8] | R9 | R | 1 | 96kHz rate support: 1 = yes, 0 = no. |
| [7] | R8 | R | 0 | 88.2kHz rate support: 1 = yes, 0 = no. |
| [6] | R7 | R | 1 | 48kHz rate support: 1 = yes, 0 = no. |
| [5] | R6 | R | 1 | 44.1kHz rate support: 1 = yes, 0 = no. |
| [4] | R5 | R | 0 | 32kHz rate support: 1 = yes, 0 = no. |
| [3] | R4 | R | 0 | 22.05kHz rate support: 1 = yes, 0 = no. |
| [2] | R3 | R | 0 | 16kHz rate support: 1 = yes, 0 = no. |

6.32.3.1. *SPDIFIn PCMCap*

| Bit | Bitfield Name | RW | Reset | Description |
|-----|---------------|----|-------|--|
| [1] | R2 | R | 0 | 11.025kHz rate support: 1 = yes, 0 = no. |
| [0] | R1 | R | 0 | 8kHz rate support: 1 = yes, 0 = no. |

6.32.4. *SPDIFIn StreamCap*

| | Verb ID | Payload | Response |
|-----|---------|---------|---------------------|
| Get | F00 | 0B | See bitfield table. |

6.32.4.1. *SPDIFIn StreamCap*

| Bit | Bitfield Name | RW | Reset | Description |
|---------|---------------|----|----------|---|
| [31..3] | Rsvd | R | 00000000 | Reserved. |
| [2] | AC3 | R | 1 | AC-3 formatted data support: 1 = yes, 0 = no. |
| [1] | Float32 | R | 0 | Float32 formatted data support: 1 = yes, 0 = no. |
| [0] | PCM | R | 1 | PCM-formatted data support: 1 = yes, 0 = no. |

6.32.5. *SPDIFIn ConLst*

| | Verb ID | Payload | Response |
|-----|---------|---------|---------------------|
| Get | F00 | 0E | See bitfield table. |

6.32.5.1. *SPDIFIn ConLst*

| Bit | Bitfield Name | RW | Reset | Description |
|---------|---------------|----|--------|--|
| [31..8] | Rsvd | R | 000000 | Reserved. |
| [7] | LForm | R | 0 | Connection list format: 1 = long-form (15-bit) NID entries 0 = short-form (7-bit) NID entries. |
| [6..0] | ConL | R | 01 | Number of NID entries in connection list. |

6.32.6. *SPDIFIn ConLstEntry0*

| | Verb ID | Payload | Response |
|-----|---------|---------|---------------------|
| Get | F02 | 00 | See bitfield table. |

6.32.6.1. *ADC0 ConLstEntry0*

| Bit | Bitfield Name | RW | Reset | Description |
|----------|---------------|----|-------|----------------------------|
| [31..24] | ConL3 | R | 00 | Unused list entry. |
| [23..16] | ConL2 | R | 00 | Unused list entry. |
| [15..8] | ConL1 | R | 00 | Unused list entry. |
| [7..0] | ConL0 | R | 24 | Dig2Pin pin widget (0x24). |

6.32.7. *SPDIFIn CnvtrID*

| | Verb ID | Payload | Response |
|-----|---------|---------|---------------------|
| Get | F06 | 00 | See bitfield table. |

6.32.7.1. *SPDIFIn CnvtrID*

| Bit | Bitfield Name | RW | Reset | Description |
|---------|---------------|----|--------|---|
| [31..8] | Rsvd | R | 000000 | Reserved. |
| [7..4] | Strm | RW | 0 | Stream ID: 0h = Converter "off" 1h-Fh = valid IDs. |
| [3..0] | Ch | RW | 0 | Channel assignment ("Ch" and "Ch+1" assigned as a pair for a stereo converter). |

6.32.8. *SPDIFIn DigCnvtr*

| | Verb ID | Payload | Response |
|-----|---------|---------|---------------------|
| Get | F0D | 00 | See bitfield table. |

6.32.8.1. *SPDIFIn DigCnvtr*

| Bit | Bitfield Name | RW | Reset | Description |
|----------|---------------|----|-------|------------------------|
| [31..16] | Rsvd2 | R | 0000 | Reserved. |
| [15] | Rsvd1 | R | 0 | Reserved. |
| [14..8] | CC | RW | 00 | CC: Category Code. |
| [7] | L | RW | 0 | L: Generation Level. |
| [6] | PRO | RW | 0 | PRO: Professional. |
| [5] | AUDIO | RW | 0 | /AUDIO: Non-Audio. |
| [4] | COPY | RW | 0 | COPY: Copyright. |
| [3] | PRE | RW | 0 | PRE: Preemphasis. |
| [2] | VCFG | RW | 0 | VCFG: Validity Config. |

6.32.8.1. *SPDIFIn DigCnvtr*

| Bit | Bitfield Name | RW | Reset | Description |
|-----|---------------|----|-------|---|
| [1] | V | RW | 0 | V: Validity. |
| [0] | DigEn | RW | 0 | Digital enable: 1 = converter enabled, 0 = converter disable. |

6.32.9. *SPDIFIn OutAmpCap*

| | Verb ID | Payload | Response |
|-----|---------|---------|---------------------|
| Get | F00 | 12 | See bitfield table. |

6.32.9.1. *SPDIFIn OutAmpCap*

| Bit | Bitfield Name | RW | Reset | Description |
|----------|---------------|----|-------|--|
| [31] | Mute | R | 1 | Mute support: 1 = yes, 0 = no. |
| [30.:23] | Rsvd3 | R | 00 | Reserved. |
| [22.:16] | StepSize | R | 00 | Size of each step in the gain range: 0 to 127 = .25dB to 32dB, in .25dB steps. |
| [15] | Rsvd2 | R | 0 | Reserved. |
| [14.:8] | NumSteps | R | 00 | Number of gains steps (number of possible settings - 1). |
| [7] | Rsvd1 | R | 0 | Reserved. |
| [6.:0] | Offset | R | 00 | Indicates which step is 0dB |

6.32.10. *SPDIFIn InAmpLeft*

| | Verb ID | Payload | Response |
|-----|---------|---------|---------------------|
| Get | B20 | 00 | See bitfield table. |

6.32.10.1. SPDIFOut1 OutAmpLeft

| Bit | Bitfield Name | RW | Reset | Description |
|---------|---------------|----|--------|-------------------------------------|
| [31..8] | Rsvd2 | R | 000000 | Reserved. |
| [7] | Mute | RW | 0 | Amp mute: 1 = muted, 0 = not muted. |
| [6.:0] | Rsvd1 | R | 00 | Reserved. |

6.32.11. SPDIFIn InAmpRight

| | Verb ID | Payload | Response |
|-----|---------|---------|---------------------|
| Get | B00 | 00 | See bitfield table. |

6.32.11.1. SPDIFOut1 OutAmpRight

| Bit | Bitfield Name | RW | Reset | Description |
|---------|---------------|----|--------|-------------------------------------|
| [31..8] | Rsvd2 | R | 000000 | Reserved. |
| [7] | Mute | RW | 0 | Amp mute: 1 = muted, 0 = not muted. |
| [6.:0] | Rsvd1 | R | 00 | Reserved. |

6.32.12. SPDIFIn VS

| | Verb ID | Payload | Response |
|-----|---------|---------|---------------------|
| Get | FE0 | 00 | See bitfield table. |

6.32.12.1. SPDIFIn VS

| Bit | Bitfield Name | RW | Reset | Description |
|---------|---------------|----|---------|---|
| [31..2] | Rsvd | R | 0000000 | Reserved. |
| [1] | RoundDis | RW | 0 | SPDIF Input rounding disable: 0 = rounding is enabled, 1 = rounding is disabled |
| [0] | LoLvlSel | RW | 0 | SPDIF Input level select: 0 = standard level, 1 = low level (input buffer enabled). |

6.32.13. SPDIFIn Status

| | Verb ID | Payload | Response |
|-----|---------|---------|---------------------|
| Get | FE0 | 80 | See bitfield table. |

6.32.13.1. SPDIFIn Status

| Bit | Bitfield Name | RW | Reset | Description |
|----------|---------------|----|-------|--|
| [31..29] | RcvSmplRate | R | 7 | Received Sample Rate: 000b = 44.1kHz 001b = 48kHz 010b = 88.2kHz 011b = 96kHz 100b = 176.4kHz 101b = 192kHz 11Xb = Invalid Rate |
| [28..26] | Rsvd2 | R | 0 | Reserved |

6.32.13.1. SPDIFIn Status

| Bit | Bitfield Name | RW | Reset | Description |
|----------|---------------|----|-------|---|
| [25.:22] | OrigFS | R | 0 | Original Sample Rate (per IEC60958-3 spec): 0000b = Original sampling frequency not indicated 0001b = 192kHz 0010b = 12kHz 0011b = 176.4kHz 0100b = Reserved 0101b = 96kHz 0110b = 8kHz 0111b = 88.2kHz 1000b = 16kHz 1001b = 24kHz 1010b = 11.025kHz 1011b = 22.05kHz 1100b = 32kHz 1101b = 48kHz 1110b = Reserved 1111b = 44.1kHz |
| [21.:20] | CA | R | 0 | Clock Accuracy (per IEC60958-3 spec): 00b = Level II 01b = Level I 10b = Level III 11b = Reserved |
| [19.:16] | FS | R | 0 | Sample Rate (per IEC60958-3 spec): 0000b = 44.1kHz 0001b = Original sampling frequency not indicated 0010b = 48kHz 0011b = 32kHz 0100b = 22.05kHz 0101b = Reserved 0110b = 24kHz 0111b = Reserved 1000b = 88.2kHz 1001b = Reserved 1010b = 96kHz 1011b = Reserved 1100b = 176.4kHz 1101b = Reserved 1110b = 192kHz 1111b = Reserved |

6.32.13.1. SPDIFIn Status

| Bit | Bitfield Name | RW | Reset | Description |
|----------|---------------|----|-------|--|
| [15.:12] | CN | R | 0 | Channel Number (per IEC60958-3 spec): 0000b = Do not take into account 0001b = Channel 1 (Left channel for stereo channel format) 0010b = Channel 2 (Right channel for stereo channel format) 0011b-1111b = Channel 3-15 |
| [11.:9] | SmplWrdL | R | 0 | Sample Word Length (per IEC60958-3 spec): 000b = Word length not indicated 001b = Max length - 4 010b = Max length - 2 011b = Reserved 100b = Max length - 1 101b = Max length - 0 110b = Max length - 3 111b = Reserved |
| [8] | MaxWrdL | R | 0 | Max Word Length (per IEC60958-3 spec): 0 = 20 bits, 1 = 24 bits. |
| [7] | NoBlkChk | RW | 0 | Disable Sample Block Checking |
| [6.:5] | Rsvd | R | 0 | Reserved |
| [4.:3] | ParityLimit | RW | 0 | SPDIFIn Parity Limit: 00b = 4 Parity errors 01b = 3 Parity errors 10b = 2 Parity errors 11b = 1 Parity error |
| [2] | SPRun | R | 0 | SPDIFIn Running 0 = no signal on SPDIFIn Pin, 1 = Signal on SPDIFIn pin. |
| [1] | SiPerr | RW | 0 | SPDIFIn Parity Error: 0 = No error detected, 1 = Error detected (write 0 to clear). |
| [0] | CopyInv | RW | 0 | Copyright Invert: 0 = Do not invert COPY bit, 1 = Invert COPY bit. |

6.33. InPort0Mux Node (NID = 28)

6.33.1. InPort0Mux WCap

| | Verb ID | Payload | Response |
|-----|---------|---------|---------------------|
| Get | F00 | 09 | See bitfield table. |

6.33.1.1. InPort0Mux WCap

| Bit | Bitfield Name | RW | Reset | Description |
|----------|---------------|----|-------|---|
| [31..24] | Rsvd2 | R | 00 | Reserved. |
| [23..20] | Type | R | 3 | Widget type: 0h = Out Converter; 1h = In Converter; 2h = Summing (Mixer); 3h = Selector (Mux); 4h = Pin Complex; 5h = Power; 6h = Volume Knob; 7h = Beep Generator; 8h-Eh = Reserved; Fh = Vendor Defined |
| [19..16] | Delay | R | 0 | Number of sample delays through widget. |
| [15..12] | Rsvd1 | R | 0 | Reserved. |
| [11] | SwapCap | R | 0 | Left/right swap support: 1 = yes 0 = no. |
| [10] | PwrCntrl | R | 0 | Power state support: 1 = yes 0 = no. |
| [9] | Dig | R | 0 | Digital stream support: 1 = yes (digital) 0 = no (analog). |
| [8] | ConnList | R | 1 | Connection list present: 1 = yes 0 = no. |
| [7] | UnSolCap | R | 0 | Unsolicited response support: 1 = yes 0 = no. |
| [6] | ProcWidget | R | 0 | Processing state support: 1 = yes 0 = no. |
| [5] | Stripe | R | 0 | Striping support: 1 = yes 0 = no. |
| [4] | FormatOvrd | R | 0 | Stream format override: 1 = yes 0 = no. |
| [3] | AmpParOvrd | R | 0 | Amplifier capabilities override: 1 = yes no. |
| [2] | OutAmpPrsnt | R | 0 | Output amp present: 1 = yes 0 = no. |

6.33.1.1. *InPort0Mux WCap*

| Bit | Bitfield Name | RW | Reset | Description |
|-----|---------------|----|-------|---|
| [1] | InAmpPrsnt | R | 0 | Input amp present: 1 = yes 0 = no. |
| [0] | Stereo | R | 1 | Stereo stream support: 1 = yes (stereo) 0 = no (mono). |

6.33.2. *InPort0Mux ConLst*

| | Verb ID | Payload | Response |
|-----|---------|---------|---------------------|
| Get | F00 | 0E | See bitfield table. |

6.33.2.1. *InPort0Mux ConLst*

| Bit | Bitfield Name | RW | Reset | Description |
|---------|---------------|----|--------|--|
| [31..8] | Rsvd | R | 000000 | Reserved. |
| [7] | LForm | R | 0 | Connection list format: 1 = long-form (15-bit) NID entries 0 = short-form (7-bit) NID entries. |
| [6..0] | ConL | R | 04 | Number of NID entries in connection list. |

6.33.3. *InPort0Mux ConLstEntry0*

| | Verb ID | Payload | Response |
|-----|---------|---------|---------------------|
| Get | F02 | 00 | See bitfield table. |

6.33.3.1. *InPort0Mux ConLstEntry0*

| Bit | Bitfield Name | RW | Reset | Description |
|----------|---------------|----|-------|---------------------------|
| [31..24] | ConL3 | R | 0F | Port F Pin widget (0x0F). |
| [23..16] | ConL2 | R | 0D | Port D Pin widget (0x0D) |

6.33.3.1. *InPort0Mux ConLstEntry0*

| Bit | Bitfield Name | RW | Reset | Description |
|---------|---------------|----|-------|--------------------------|
| [15.:8] | ConL1 | R | 0B | Port B Pin widget (0x0B) |
| [7.:0] | ConL0 | R | 0A | Port A Pin widget (0x0A) |

6.33.4. *InPort0Mux ConSelectCtrl*

| | Verb ID | Payload | Response |
|-----|---------|---------|---------------------|
| Get | F01 | 00 | See bitfield table. |

6.33.4.1. *InPort0Mux ConSelectCtrl*

| Bit | Bitfield Name | RW | Reset | Description |
|---------|---------------|----|----------|----------------------------------|
| [31.:2] | Rsvd | R | 00000000 | Reserved. |
| [1.:0] | Index | RW | 0 | Connection select control index. |

6.34. *InPort1Mux Node (NID = 29)*6.34.1. *InPort1Mux WCap*

| | Verb ID | Payload | Response |
|-----|---------|---------|---------------------|
| Get | F00 | 09 | See bitfield table. |

6.34.1.1. *InPort1Mux WCap*

| Bit | Bitfield Name | RW | Reset | Description |
|----------|---------------|----|-------|---|
| [31.:24] | Rsvd2 | R | 00 | Reserved. |
| [23.:20] | Type | R | 3 | Widget type: 0h = Out Converter; 1h = In Converter; 2h = Summing (Mixer); 3h = Selector (Mux); 4h = Pin Complex; 5h = Power; 6h = Volume Knob; 7h = Beep Generator; 8h-Eh = Reserved; Fh = Vendor Defined |
| [19.:16] | Delay | R | 0 | Number of sample delays through widget. |
| [15.:12] | Rsvd1 | R | 0 | Reserved. |
| [11] | SwapCap | R | 0 | Left/right swap support: 1 = yes 0 = no. |
| [10] | PwrCntrl | R | 0 | Power state support: 1 = yes 0 = no. |
| [9] | Dig | R | 0 | Digital stream support: 1 = yes (digital) 0 = no (analog). |
| [8] | ConnList | R | 1 | Connection list present: 1 = yes 0 = no. |
| [7] | UnSolCap | R | 0 | Unsolicited response support: 1 = yes 0 = no. |
| [6] | ProcWidget | R | 0 | Processing state support: 1 = yes 0 = no. |
| [5] | Stripe | R | 0 | Striping support: 1 = yes 0 = no. |
| [4] | FormatOvrd | R | 0 | Stream format override: 1 = yes 0 = no. |
| [3] | AmpParOvrd | R | 0 | Amplifier capabilities override: 1 = yes no. |
| [2] | OutAmpPrsnt | R | 0 | Output amp present: 1 = yes 0 = no. |
| [1] | InAmpPrsnt | R | 0 | Input amp present: 1 = yes 0 = no. |
| [0] | Stereo | R | 1 | Stereo stream support: 1 = yes (stereo) 0 = no (mono). |

6.34.2. InPort1Mux ConLst

| | Verb ID | Payload | Response |
|-----|---------|---------|---------------------|
| Get | F00 | 0E | See bitfield table. |

6.34.2.1. InPort1Mux ConLst

| Bit | Bitfield Name | RW | Reset | Description |
|---------|---------------|----|--------|--|
| [31..8] | Rsvd | R | 000000 | Reserved. |
| [7] | LForm | R | 0 | Connection list format: 1 = long-form (15-bit) NID entries 0 = short-form (7-bit) NID entries. |
| [6..0] | ConL | R | 04 | Number of NID entries in connection list. |

6.34.3. InPort1Mux ConLstEntry0

| | Verb ID | Payload | Response |
|-----|---------|---------|---------------------|
| Get | F02 | 00 | See bitfield table. |

6.34.3.1. InPort1Mux ConLstEntry0

| Bit | Bitfield Name | RW | Reset | Description |
|----------|---------------|----|-------|--------------------------|
| [31..24] | ConL3 | R | 11 | Port H Pin widget (0x11) |
| [23..16] | ConL2 | R | 10 | Port G Pin widget (0x10) |
| [15..8] | ConL1 | R | 0E | Port E Pin widget (0x0E) |
| [7..0] | ConL0 | R | 0A | Port A Pin widget (0x0A) |

6.34.4. InPort1Mux ConSelectCtrl

| | Verb ID | Payload | Response |
|-----|---------|---------|---------------------|
| Get | F01 | 00 | See bitfield table. |

6.34.4.1. InPort1Mux ConSelectCtrl

| Bit | Bitfield Name | RW | Reset | Description |
|---------|---------------|----|----------|----------------------------------|
| [31..2] | Rsvd | R | 00000000 | Reserved. |
| [1..0] | Index | RW | 0 | Connection select control index. |

6.35. InPort2Mux Node (NID = 2A)**6.35.1. InPort2Mux WCap**

| | Verb ID | Payload | Response |
|-----|---------|---------|---------------------|
| Get | F00 | 09 | See bitfield table. |

6.35.1.1. InPort2Mux WCap

| Bit | Bitfield Name | RW | Reset | Description |
|----------|---------------|----|-------|---|
| [31..24] | Rsvd2 | R | 00 | Reserved. |
| [23..20] | Type | R | 3 | Widget type: 0h = Out Converter; 1h = In Converter; 2h = Summing (Mixer); 3h = Selector (Mux); 4h = Pin Complex; 5h = Power; 6h = Volume Knob; 7h = Beep Generator; 8h-Eh = Reserved; Fh = Vendor Defined |
| [19..16] | Delay | R | 0 | Number of sample delays through widget. |
| [15..12] | Rsvd1 | R | 0 | Reserved. |
| [11] | SwapCap | R | 0 | Left/right swap support: 1 = yes 0 = no. |

6.35.1.1. *InPort2Mux WCap*

| Bit | Bitfield Name | RW | Reset | Description |
|------|---------------|----|-------|---|
| [10] | PwrCntrl | R | 0 | Power state support: 1 = yes 0 = no. |
| [9] | Dig | R | 0 | Digital stream support: 1 = yes (digital) 0 = no (analog). |
| [8] | ConnList | R | 1 | Connection list present: 1 = yes 0 = no. |
| [7] | UnSolCap | R | 0 | Unsolicited response support: 1 = yes 0 = no. |
| [6] | ProcWidget | R | 0 | Processing state support: 1 = yes 0 = no. |
| [5] | Stripe | R | 0 | Striping support: 1 = yes 0 = no. |
| [4] | FormatOvrd | R | 0 | Stream format override: 1 = yes 0 = no. |
| [3] | AmpParOvrd | R | 0 | Amplifier capabilities override: 1 = yes no. |
| [2] | OutAmpPrsnt | R | 0 | Output amp present: 1 = yes 0 = no. |
| [1] | InAmpPrsnt | R | 0 | Input amp present: 1 = yes 0 = no. |
| [0] | Stereo | R | 1 | Stereo stream support: 1 = yes (stereo) 0 = no (mono). |

6.35.2. *InPort2Mux ConLst*

| | Verb ID | Payload | Response |
|-----|---------|---------|---------------------|
| Get | F00 | 0E | See bitfield table. |

6.35.2.1. *InPort2Mux ConLst*

| Bit | Bitfield Name | RW | Reset | Description |
|---------|---------------|----|--------|-------------|
| [31..8] | Rsvd | R | 000000 | Reserved. |

6.35.2.1. *InPort2Mux ConLst*

| Bit | Bitfield Name | RW | Reset | Description |
|--------|---------------|----|-------|--|
| [7] | LForm | R | 0 | Connection list format: 1 = long-form (15-bit) NID entries 0 = short-form (7-bit) NID entries. |
| [6.:0] | ConL | R | 04 | Number of NID entries in connection list. |

6.35.3. *InPort2Mux ConLstEntry0*

| | Verb ID | Payload | Response |
|-----|---------|---------|---------------------|
| Get | F02 | 00 | See bitfield table. |

6.35.3.1. *InPort2Mux ConLstEntry0*

| Bit | Bitfield Name | RW | Reset | Description |
|----------|---------------|----|-------|--------------------------|
| [31.:24] | ConL3 | R | 11 | Port H Pin widget (0x11) |
| [23.:16] | ConL2 | R | 10 | Port G Pin widget (0x10) |
| [15.:8] | ConL1 | R | 0C | Port C Pin widget (0x0C) |
| [7.:0] | ConL0 | R | 0B | Port B Pin widget (0x0B) |

6.35.4. *InPort1Mux ConSelectCtrl*

| | Verb ID | Payload | Response |
|-----|---------|---------|---------------------|
| Get | F01 | 00 | See bitfield table. |

6.35.4.1. *InPort1Mux ConSelectCtrl*

| Bit | Bitfield Name | RW | Reset | Description |
|---------|---------------|----|----------|----------------------------------|
| [31..2] | Rsvd | R | 00000000 | Reserved. |
| [1..0] | Index | RW | 0 | Connection select control index. |

6.36. InPort3Mux Node (NID = 2B)

6.36.1. *InPort3Mux WCap*

| | Verb ID | Payload | Response |
|-----|---------|---------|---------------------|
| Get | F00 | 09 | See bitfield table. |

6.36.1.1. *InPort3Mux WCap*

| Bit | Bitfield Name | RW | Reset | Description |
|----------|---------------|----|-------|---|
| [31..24] | Rsvd2 | R | 00 | Reserved. |
| [23..20] | Type | R | 3 | Widget type: 0h = Out Converter; 1h = In Converter; 2h = Summing (Mixer); 3h = Selector (Mux); 4h = Pin Complex; 5h = Power; 6h = Volume Knob; 7h = Beep Generator; 8h-Eh = Reserved; Fh = Vendor Defined |
| [19..16] | Delay | R | 0 | Number of sample delays through widget. |
| [15..12] | Rsvd1 | R | 0 | Reserved. |
| [11] | SwapCap | R | 0 | Left/right swap support: 1 = yes 0 = no. |
| [10] | PwrCntrl | R | 0 | Power state support: 1 = yes 0 = no. |
| [9] | Dig | R | 0 | Digital stream support: 1 = yes (digital) 0 = no (analog). |
| [8] | ConnList | R | 1 | Connection list present: 1 = yes 0 = no. |

6.36.1.1. *InPort3Mux WCap*

| Bit | Bitfield Name | RW | Reset | Description |
|-----|---------------|----|-------|---|
| [7] | UnSolCap | R | 0 | Unsolicited response support: 1 = yes 0 = no. |
| [6] | ProcWidget | R | 0 | Processing state support: 1 = yes 0 = no. |
| [5] | Stripe | R | 0 | Striping support: 1 = yes 0 = no. |
| [4] | FormatOvrd | R | 0 | Stream format override: 1 = yes 0 = no. |
| [3] | AmpParOvrd | R | 0 | Amplifier capabilities override: 1 = yes no. |
| [2] | OutAmpPrsnt | R | 0 | Output amp present: 1 = yes 0 = no. |
| [1] | InAmpPrsnt | R | 0 | Input amp present: 1 = yes 0 = no. |
| [0] | Stereo | R | 1 | Stereo stream support: 1 = yes (stereo) 0 = no (mono). |

6.36.2. *InPort3Mux ConLst*

| | Verb ID | Payload | Response |
|-----|---------|---------|---------------------|
| Get | F00 | 0E | See bitfield table. |

6.36.2.1. *InPort3Mux ConLst*

| Bit | Bitfield Name | RW | Reset | Description |
|---------|---------------|----|--------|--|
| [31..8] | Rsvd | R | 000000 | Reserved. |
| [7] | LForm | R | 0 | Connection list format: 1 = long-form (15-bit) NID entries 0 = short-form (7-bit) NID entries. |
| [6..0] | ConL | R | 04 | Number of NID entries in connection list. |

6.36.3. InPort3Mux ConLstEntry0

| | Verb ID | Payload | Response |
|-----|---------|---------|---------------------|
| Get | F02 | 00 | See bitfield table. |

6.36.3.1. InPort3Mux ConLstEntry0

| Bit | Bitfield Name | RW | Reset | Description |
|----------|---------------|----|-------|--|
| [31..24] | ConL3 | R | 00 | Unused list entry |
| [23..16] | ConL2 | R | 00 | Unused list entry |
| [15] | ConL1Range | R | 1 | 1 = ConL0..ConL1 defines a range of selectable inputs. |
| [14..8] | ConL1 | R | 17 | DAC2 (0x17) |
| [7..0] | ConL0 | R | 15 | DAC0 (0x15) |

6.36.4. InPort3Mux ConSelectCtrl

| | Verb ID | Payload | Response |
|-----|---------|---------|---------------------|
| Get | F01 | 00 | See bitfield table. |

6.36.4.1. InPort3Mux ConSelectCtrl

| Bit | Bitfield Name | RW | Reset | Description |
|---------|---------------|----|----------|----------------------------------|
| [31..2] | Rsvd | R | 00000000 | Reserved. |
| [1..0] | Index | RW | 0 | Connection select control index. |

7. DISCLAIMER

While the information presented herein has been checked for both accuracy and reliability, manufacturer assumes no responsibility for either its use or for the infringement of any patents or other rights of third parties, which would result from its use. No other circuits, patents, or licenses are implied. This product is intended for use in normal commercial applications. Any other applications, such as those requiring extended temperature range, high reliability, or other extraordinary environmental requirements, are not recommended without additional processing by manufacturer. Manufacturer reserves the right to change any circuitry or specifications without notice. Manufacturer does not authorize or warrant any product for use in life support devices or critical medical instruments.

8. PINOUTS

8.1. Pin Assignment

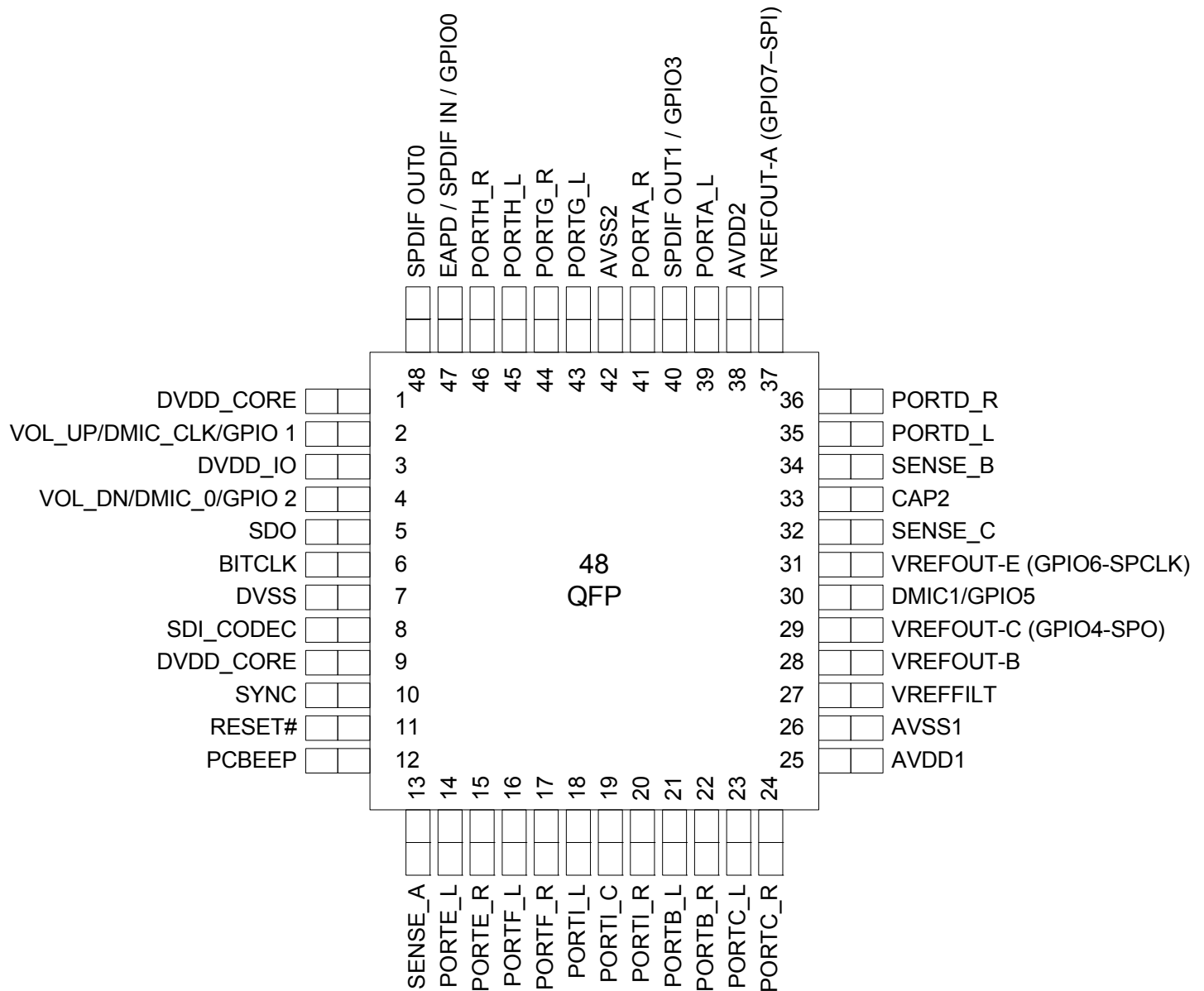

Figure 13. Pin Assignment

8.2. Pin Tables for 48-pin QFP

| Pin Name | Pin Function | I/O | Internal Pull-up/Pull-down | 48 pin location |
|--------------------------|---|--------------|--|-----------------|
| Volume Up/DMIC_CLK/GPIO1 | Volume Control <u>OR</u> Digital Mic clock output <u>OR</u> General Purpose I/O | I/O(Digital) | 60k Pull-Up with Volume/GPIO or 60k Pull-down with Digital Mic | 2 |
| Volume Down/DMIC0/GPIO2 | Volume Control <u>OR</u> Digital Mic 01 Input <u>OR</u> General Purpose I/O | I/O(Digital) | 60k Pull-Up with Volume/GPIO or 60k Pull-down with Digital Mic | 4 |
| SDO | HD Audio Serial Data output (inbound stream) | I/O(Digital) | None | 5 |
| BITCLK | HD Audio Bit Clock | I(Digital) | None | 6 |
| SDI_CODEC | HD Audio Serial Data (outbound stream), audio module | I/O(Digital) | None | 8 |
| SYNC | HD Audio Frame Sync | I(Digital) | None | 10 |
| RESET# | HD Audio Reset | I(Digital) | None | 11 |
| DMIC 1 / GPIO5 | Second digital mic input or Analog GPIO5 | I/O(Analog) | 60k Pull-Up with GPIO or 60k Pull-Down with Digital Mic | 30 |
| SPDIF OUT1 | SECOND SPDIF OUT / Analog GPIO3 | I/O(Analog) | 60K Pull-Down with SPDIF or 60K pull-up with GPIO | 40 |
| GPIO0/EAPD/SPDIF-IN | General Purpose I/O,EAPD, SPDIF In | I/O(Digital) | 60K Pull-Down with SPDIF-IN and EAPD, 60K Pull-Up with GPIO | 47 |
| S/PDIF-OUT0 | SPDIF digital output (60K internal pull-down) | O(Digital) | 60K Pull-Down | 48 |

Table 22. Digital Pins

| Pin Name | Pin Function | I/O | Internal Pull-up/Pull-down | 48 pin location |
|----------|--|-------------|----------------------------|-----------------|
| PCBEEP | Analog PC Beep | I(Analog) | None | 12 |
| SENSE_A | Jack insertion detection Ports A,B,C,D | I(Analog) | None | 13 |
| PORTE_L | Port E I/O Left | I/O(Analog) | None | 14 |
| PORTE_R | Port E I/O Right | I/O(Analog) | None | 15 |

Table 23. Analog Pins

| Pin Name | Pin Function | I/O | Internal Pull-up/Pull-down | 48 pin location |
|-------------------|---|-------------|----------------------------|-----------------|
| PORTF_L | Port F I/O Left | I/O(Analog) | None | 16 |
| PORTF_R | Port F I/O Right | I/O(Analog) | None | 17 |
| PORTI_L | Port I Input Left | I(Analog) | None | 18 |
| PORTI_Comm | Port I signal Common | I(Analog) | None | 19 |
| PORTI_R | Port I Input Right | I(Analog) | None | 20 |
| PORTB_L (HP) | Port B I/O Left | I/O(Analog) | None | 21 |
| PORTB_R (HP) | Port B I/O Right | I/O(Analog) | None | 22 |
| PORTC_L | Port C I/O Left | I/O(Analog) | None | 23 |
| PORTC_R | Port C I/O Right | I/O(Analog) | None | 24 |
| VREFFILT | Analog Virtual Ground | O(Analog) | None | 27 |
| VREFOUT-B | Reference Voltage out drive (intended for mic bias) for Port B | O(Analog) | None | 28 |
| VREFOUT-C / GPIO4 | Reference Voltage out drive (intended for mic bias) for Port C / Analog GPIO4 | I/O(Analog) | 60k Pull-Up with GPIO | 29 |
| VREFOUT-E / GPIO6 | Reference Voltage out drive (intended for mic bias) for Port E / Analog GPIO6 | I/O(Analog) | 60k Pull-Up with GPIO | 31 |
| SENSE C | Jack insertion detection Port I | I(Analog) | None | 32 |
| CAP2 | ADC reference Cap | O(Analog) | None | 33 |
| SENSE B | Jack insertion detection Ports E, F, G, H | I(Analog) | None | 34 |
| PORTD_L (HP) | Port D I/O Left | I/O(Analog) | None | 35 |
| PORTD_R (HP) | Port D I/O Right | I/O(Analog) | None | 36 |
| VREFOUT-A / GPIO7 | Reference Voltage out drive (intended for mic bias) for Port A / Analog GPIO7 | I/O(Analog) | 60k Pull-Up with GPIO | 37 |
| PORTA_L (HP) | Port A Output Left | I/O(Analog) | None | 39 |
| PORTA_R (HP) | Port A I/O Right | I/O(Analog) | None | 41 |
| PORTG_L | Port G I/O Left | I/O(Analog) | None | 43 |
| PORTG_R | Port G I/O Right | I/O(Analog) | None | 44 |
| PORTH_L | Port H I/O Left | I/O(Analog) | None | 45 |
| PORTH_R | Port H I/O Right | I/O(Analog) | None | 46 |

Table 23. Analog Pins

| Pin Name | Pin Function | I/O | Internal Pull-up/Pull-down | 48 pin location |
|-----------|--------------------|------------|----------------------------|-----------------|
| DVDD_CORE | Digital Vdd = 3.3V | I(Digital) | None | 1 |

Table 24. Power Pins

| Pin Name | Pin Function | I/O | Internal Pull-up/Pull-down | 48 pin location |
|-----------|----------------------------------|------------|----------------------------|-----------------|
| DVDD_IO | Reference Voltage (1.5V or 3.3V) | I(Digital) | None | 3 |
| DVSS | Digital Ground | I(Digital) | None | 7 |
| DVDD_CORE | Digital Vdd= 3.3V | I(Digital) | None | 9 |
| AVDD1 | Analog Vdd=5.0V or 3.3V | I(Analog) | None | 25 |
| AVSS1 | Analog Ground | I(Analog) | None | 26 |
| AVDD2 | Analog Vdd=5.0V or 3.3V | I(Analog) | None | 38 |
| AVSS2 | Analog Ground | I(Analog) | None | 42 |

Table 24. Power Pins

9. PACKAGE OUTLINE AND PACKAGE DIMENSIONS

Package dimensions are kept current with JEDEC Publication No. 95

9.1. 48-Pin QFP Package

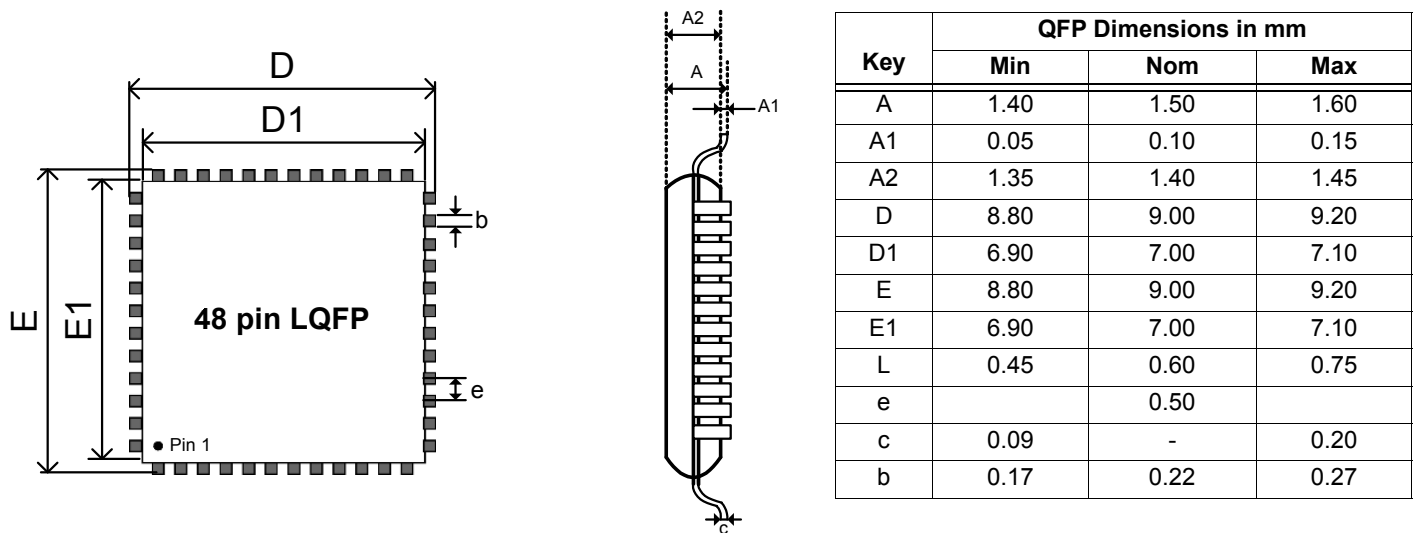

Figure 14. 48-pin QFP Package Drawing

10. SOLDER REFLOW PROFILE

10.1. Standard Reflow Profile Data

Note: These devices can be hand soldered at 360 °C for 3 to 5 seconds.

FROM: IPC / JEDEC J-STD-020C "Moisture/Reflow Sensitivity Classification for Nonhermetic Solid State Surface Mount Devices" (www.jedec.org/download).

| Profile Feature | Pb Free Assembly |
|---|--|
| Average Ramp-Up Rate ($T_{s_{max}} - T_p$) | 3 °C / second max |
| Preheat: Temperature Min ($T_{s_{min}}$) Temperature Max ($T_{s_{max}}$) Time ($t_{s_{min}} - t_{s_{max}}$) | 150 °C 200 °C 60 - 180 seconds |
| Time maintained above: Temperature (T_L) Time (t_L) | 217 °C 60 - 150 seconds |
| Peak / Classification Temperature (T_p) | See "Package Classification Reflow Temperatures" |
| Time within 5 °C of actual Peak Temperature (t_p) | 20 - 40 seconds |
| Ramp-Down rate | 6 °C / second max |
| Time 25 °C to Peak Temperature | 8 minutes max |

Note: All temperatures refer to topside of the package, measured on the package body surface.

Table 25. Standard Reflow Profile

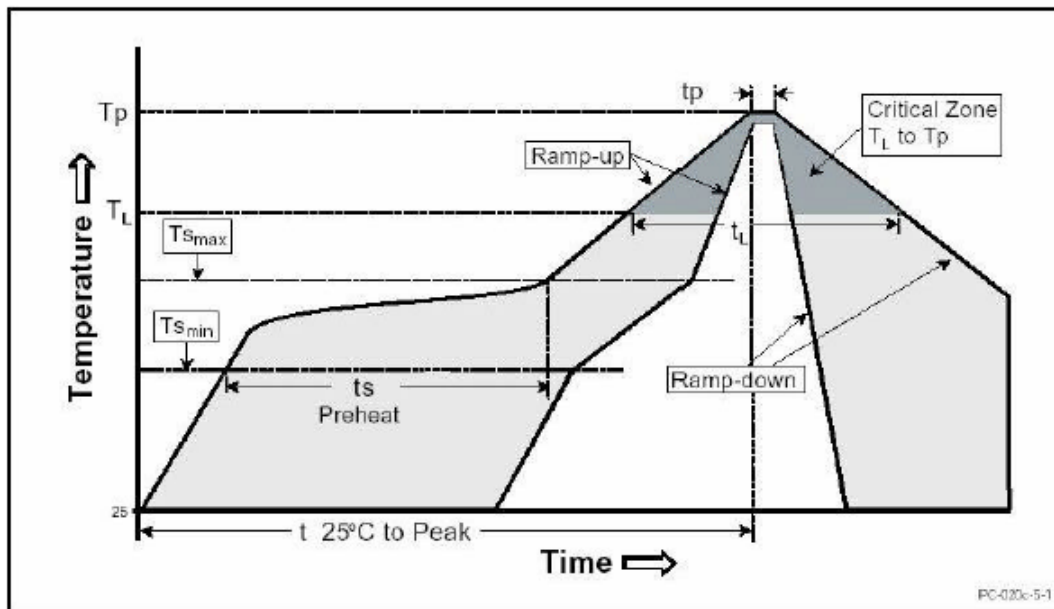

Figure 15. Solder Reflow Profile

10.2. Pb Free Process - Package Classification Reflow Temperatures

| Package Type | MSL | Reflow Temperature |
|--------------|-----|--------------------|
| QFP 48-pin | 3 | 260 °C |

Table 26. Pb-Free Process Reflow

11. REVISION HISTORY

| Revision | Date | Description of Change |
|----------|----------------|--|
| 0.6 | July 19, 2007 | initial release |
| 0.9 | Oct 17, 2007 | added detailed widget information, updated power consumption specification |
| 0.91 | Dec 14, 2007 | updated Analog BC Peep description, updated the functional and widget diagrams for the new Analog PC Beep typology, added AnaBeep widget in AFG NID=-01h |
| 1.0 | March 19, 2008 | removed preliminary, updated performance numbers |
| 1.0a | June 24, 2010 | corrected section 6.25.4.1. ADC0Mux ConSelectCtrl bit numbering |
| 1.3 | August 2011 | Consolidated standard and Industrial Temp datasheets into one file. Set revision at 1.3 to match version of additional product family parts. |

Innovate with IDT audio for high fidelity. Contact:

www.IDT.com

For Sales

800-345-7015
408-284-8200
Fax: 408-284-2775

For Tech Support

HA.CM@idt.com



Corporate Headquarters

Integrated Device Technology, Inc.
6024 Silver Creek Valley Road
San Jose, CA 95138
United States
800 345 7015
+408 284 8200 (outside U.S.)

Europe

IDT Europe, Limited
Prime House
Barnett Wood Lane
Leatherhead, Surrey
United Kingdom KT22 7DE
+44 1372 363 339

Данный компонент на территории Российской Федерации

Вы можете приобрести в компании MosChip.

Для оперативного оформления запроса Вам необходимо перейти по данной ссылке:

<http://moschip.ru/get-element>

Вы можете разместить у нас заказ для любого Вашего проекта, будь то серийное производство или разработка единичного прибора.

В нашем ассортименте представлены ведущие мировые производители активных и пассивных электронных компонентов.

Нашей специализацией является поставка электронной компонентной базы двойного назначения, продукции таких производителей как XILINX, Intel (ex.ALTERA), Vicor, Microchip, Texas Instruments, Analog Devices, Mini-Circuits, Amphenol, Glenair.

Сотрудничество с глобальными дистрибьюторами электронных компонентов, предоставляет возможность заказывать и получать с международных складов практически любой перечень компонентов в оптимальные для Вас сроки.

На всех этапах разработки и производства наши партнеры могут получить квалифицированную поддержку опытных инженеров.

Система менеджмента качества компании отвечает требованиям в соответствии с ГОСТ Р ИСО 9001, ГОСТ РВ 0015-002 и ЭС РД 009

Офис по работе с юридическими лицами:

105318, г.Москва, ул.Щербаковская д.3, офис 1107, 1118, ДЦ «Щербаковский»

Телефон: +7 495 668-12-70 (многоканальный)

Факс: +7 495 668-12-70 (доб.304)

E-mail: info@moschip.ru

Skype отдела продаж:

moschip.ru

moschip.ru_4

moschip.ru_6

moschip.ru_9