

Low-Peak® CUBEFuse® With and Without Indication

Finger-Safe, Dual-Element, Time-Delay Class J Performance Fuse, 1-100A, 600Vac/300Vdc



70-100A Case Size 35-60A Case Size 1-30A Case Size

Catalog Symbols: TCF_ Indicating fuse (6-100A)
TCF_RN Non-indicating fuse (1-100A)

Dual-Element, Time-Delay Fuse: 10 Seconds Minimum Operating Time at 500% Rated Current

Ampere Rating: 1 to 100A

Voltage Rating: 600Vac/300Vdc

Interrupting Rating: 300kA RMS Sym. (UL)
200kA RMS Sym. (CSA)
100kA DC (UL & CSA)

Agency Information:

- UL Listed Special Purpose Fuse: Guide JFHR, File E56412
- CSA Certified Fuse: Class 1422- 02, File 53787
- CE compliance for the European Union low voltage directive

Other Ratings/Specifications:

Watts Loss at rated current: TCF30: 3.99W
TCF60: 6.23W
TCF100: 9.51W

Operating and Storage Temperature Range: 14 to 149°F(-10 to 65°C)

Material Specifications:

- Case: Glass filled PES (Polyethersulfone)
- Terminals: Copper alloy
- Terminal plating: Electroless tin
- Indicator lens: PES (Polyethersulfone) (indicating version only)
- Indicator: Energetic chemical

Carton Quantity and Weight

Amp Rating	Carton Qty.	Weight Per Carton	
		lbs	kg
TCF1-30A	12	1.39	0.63
TCF35-60A	12	1.42	0.65
TCF70-100A	6	1.74	0.79

Catalog Numbers (amp rating)

Indicating CUBEFuse					
TCF6	TCF10	TCF15	TCF17-½	TCF20	TCF25
TCF30	TCF35	TCF40	TCF45	TCF50	TCF60
TCF70	TCF80	TCF90	TCF100		
Non-Indicating CUBEFuse					
TCF1RN	TCF3RN	TCF6RN	TCF10RN	TCF15RN	TCF17-½RN
TCF20RN	TCF25RN	TCF30RN	TCF35RN	TCF40RN	TCF45RN
TCF50RN	TCF60RN	TCF70RN	TCF80RN	TCF90RN	TCF100RN

Features and Product Benefits

- The world's first finger-safe power fuse system.
- Smallest footprint of any class fuse including Class J, CC, T and RK.
- Meets Class J time-delay electrical performance requirements.
- Available with and without open fuse indication to meet every customer requirement.
- The indicating version features *easyID™* open fuse technology for faster troubleshooting and reduced downtime.
- Faster response to damaging faults to help reduce destructive thermal and magnetic forces.
- True dual-element fuse construction with a minimum of 10 seconds time-delay at 500% of rating.
- Long time-delay minimizes nuisance circuit openings due to temporary overloads and transient surges.
- High interrupting rating to safely interrupt faults up to 300kA.
- No venting of arc or molten metal and gases during opening.
- Robust cycling and inrush current withstand.
- Low let-through currents under fault conditions.
- Provides Type 2 "No Damage" protection for IEC motors starters when properly sized.
- Easy selective coordination with any other Cooper Bussmann® Low-Peak® Class L, J and RK1 fuse with simple 2:1 amp ration between upstream and downstream fuses.

CUBEFuse Holders, Disconnects and Safety Switch

The CUBEFuse is used in the following Cooper Bussmann® products.



TCFH_N 100, 60 & 30A Holders. Data Sheet 9007



CCP_CF 1-, 2- & 3-Pole switched disconnects. Data Sheet 1157



CCPB 1-, 2- & 3-Pole disconnects for the Quik-Spec™ Coordination Panelboard. Data Sheet 1160



CF_ Quik-Spec™ Safety Switch disconnect (optional window). Data Sheet 1156

TCF_ and TCF_RN Dimensions – in (mm)

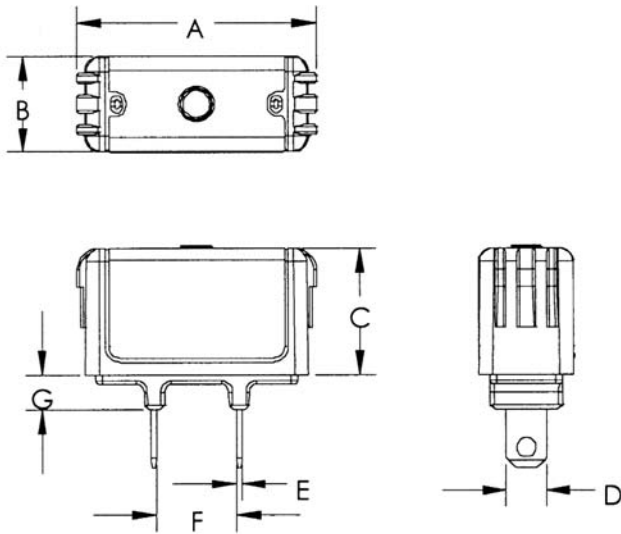

Fuse Amps	Dimensions - in (mm)						
	A	B	C	D	E	F	G
1-15	1.88 (47.75)	0.75 (19.05)	1.00 (25.40)	0.23 (5.84)	0.04 (1.02)	0.63 (15.88)	0.27 (6.86)
17.5-20	1.88 (47.75)	0.75 (19.05)	1.00 (25.40)	0.27 (6.86)	0.04 (1.02)	0.63 (15.88)	0.27 (6.86)
25-30	1.88 (47.75)	0.75 (19.05)	1.00 (25.40)	0.31 (7.94)	0.04 (1.02)	0.63 (15.88)	0.27 (6.86)
35-40	2.13 (54.10)	1.00 (25.40)	1.13 (28.58)	0.36 (9.14)	0.04 (1.02)	0.63 (15.88)	0.38 (9.65)
45-50	2.13 (54.10)	1.00 (25.40)	1.13 (28.58)	0.40 (10.16)	0.04 (1.02)	0.63 (15.88)	0.38 (9.65)
60	2.13 (54.10)	1.00 (25.40)	1.13 (28.58)	0.44 (11.11)	0.04 (1.02)	0.63 (15.88)	0.38 (9.65)
70-100	3.01 (76.45)	1.00 (25.40)	1.26 (32.00)	0.57 (14.4)	0.06 (1.60)	0.63 (15.88)	0.39 (9.93)

Time-Current Characteristic Curves—Average Melt

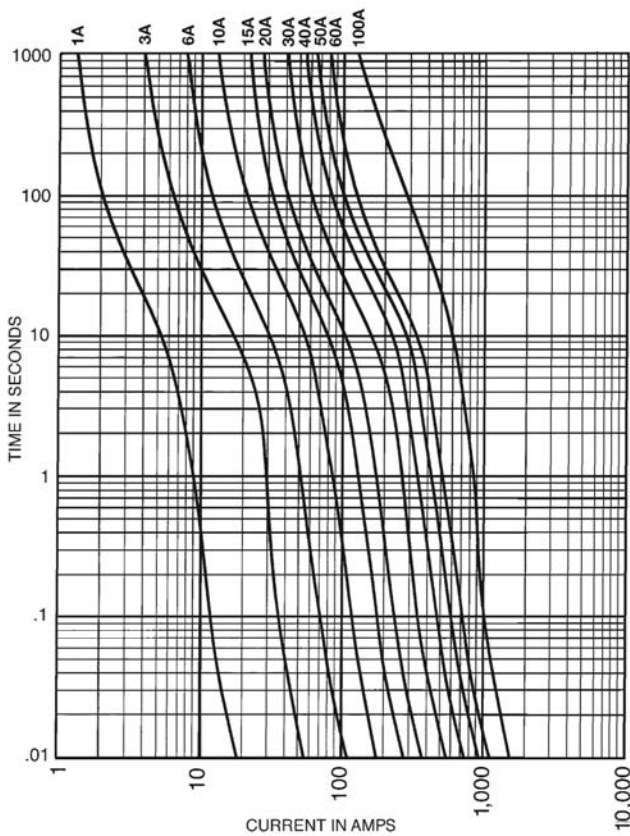

Current Limitation Curves

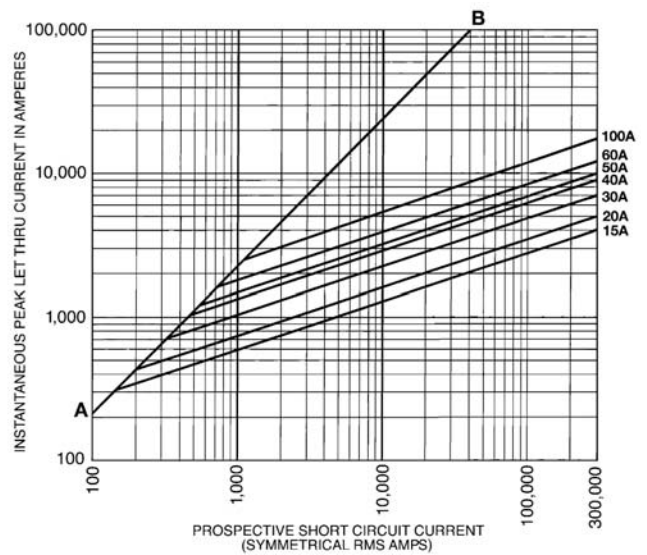

The only controlled copy of this Data Sheet is the electronic read-only version located on the Cooper Bussmann Network Drive. All other copies of this document are by definition uncontrolled. This bulletin is intended to clearly present comprehensive product data and provide technical information that will help the end user with design applications. Cooper Bussmann reserves the right, without notice, to change design or construction of any products and to discontinue or limit distribution of any products. Cooper Bussmann also reserves the right to change or update, without notice, any technical information contained in this bulletin. Once a product has been selected, it should be tested by the user in all possible applications.

Данный компонент на территории Российской Федерации

Вы можете приобрести в компании MosChip.

Для оперативного оформления запроса Вам необходимо перейти по данной ссылке:

<http://moschip.ru/get-element>

Вы можете разместить у нас заказ для любого Вашего проекта, будь то серийное производство или разработка единичного прибора.

В нашем ассортименте представлены ведущие мировые производители активных и пассивных электронных компонентов.

Нашей специализацией является поставка электронной компонентной базы двойного назначения, продукции таких производителей как XILINX, Intel (ex.ALTERA), Vicor, Microchip, Texas Instruments, Analog Devices, Mini-Circuits, Amphenol, Glenair.

Сотрудничество с глобальными дистрибьюторами электронных компонентов, предоставляет возможность заказывать и получать с международных складов практически любой перечень компонентов в оптимальные для Вас сроки.

На всех этапах разработки и производства наши партнеры могут получить квалифицированную поддержку опытных инженеров.

Система менеджмента качества компании отвечает требованиям в соответствии с ГОСТ Р ИСО 9001, ГОСТ РВ 0015-002 и ЭС РД 009

Офис по работе с юридическими лицами:

105318, г.Москва, ул.Щербаковская д.3, офис 1107, 1118, ДЦ «Щербаковский»

Телефон: +7 495 668-12-70 (многоканальный)

Факс: +7 495 668-12-70 (доб.304)

E-mail: info@moschip.ru

Skype отдела продаж:

moschip.ru

moschip.ru_4

moschip.ru_6

moschip.ru_9