

## Low-Power Single/Dual-Supply Quad Comparator with Reference

### FEATURES

- Single or Dual Power Supplies:  
Single: +2.5V to +11V  
Dual:  $\pm 1.25V$  to  $\pm 5.5V$
- Internal 1.182V  $\pm 0.75\%$  Reference
- Fully Assembled and Tested
- Push-pull TTL/CMOS-Compatible Outputs
- 2in x 3in 2-layer circuit board

DESIGNATION	QTY	DESCRIPTION
C2	1	0.1 $\mu$ F $\pm 10\%$ capacitors (0805)
R1, R4	1	40.2k $\Omega$ $\pm 1\%$ resistor (0805)
R2, R3	1	26.1k $\Omega$ $\pm 1\%$ resistor (0805)
R5, R6	1	2M $\Omega$ $\pm 1\%$ resistor (0805)
U1	1	TS9004 Comparator
INA-, INB+, OUTA, OUTB, VDD, REF, GND (6)	12	Test points

Table 1. Component List

### DESCRIPTION

The demo board for the TS9004 is a completely assembled and tested circuit board that can be used for evaluating the TS9004. The TS9004 joins Touchstone's TS9002 and TS9001-1/2 analog comparators in the "NanoWatt Analog™" high performance analog integrated circuits portfolio. The TS9004 can operate from single +2.5V to +11V supplies or from  $\pm 1.25V$  to  $\pm 5.5V$  dual supplies.

The TS9004 is fully specified over the  $-40^{\circ}C$  to  $+85^{\circ}C$  temperature range and is available in a 16-pin narrow SOIC package.

Product data sheets and additional documentation can be found on factory web site at [www.touchstonesemi.com](http://www.touchstonesemi.com).

### ORDERING INFORMATION

Order Number	Description
TS9004DB	Demo Board

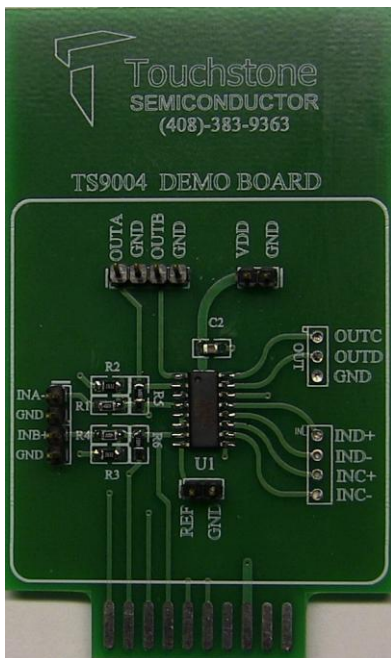

Figure 1. TS9004 Evaluation Board (Top View)

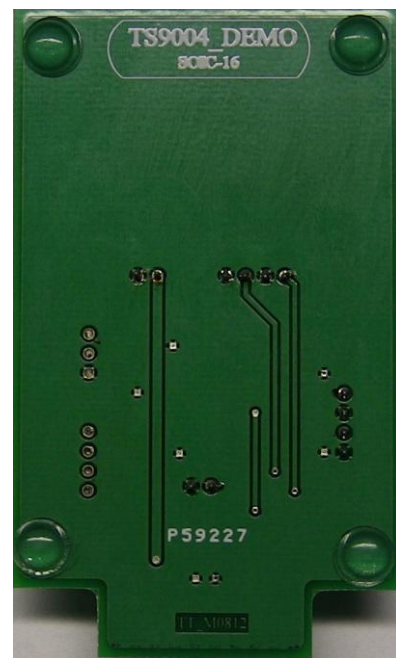

Figure 2. TS9004 Evaluation Board (Bottom View)

## DESCRIPTION

The demo board provides a configuration where only three resistors are required to set the hysteresis band,  $V_{HB}$ , as shown in Figure 3. Adding comparator hysteresis creates two trip points:  $V_{THR}$  (for the rising input voltage) and  $V_{THF}$  (for the falling input voltage). The hysteresis band ( $V_{HB}$ ) is defined as the voltage difference between the two trip points.

To design the circuit for a desired hysteresis band, refer to page 10 of the TS9004 product datasheet. To verify the trip voltages and hysteresis band using the standard resistance values, use the following equations:

$$V_{THR} = V_{REF} \times R1 \times \left( \frac{1}{R4} + \frac{1}{R3} + \frac{1}{R6} \right)$$

$$V_{THF} = V_{THR} - \frac{(R4 \times VDD)}{R6}$$

$$V_{HB} = V_{THR} - V_{THF}$$

The TS9004 demo board provides  $R1 = R4 = 40.2k\Omega$ ,  $R2 = R3 = 26.1k\Omega$ , and  $R5 = R6 = 2M\Omega$ . This sets the hysteresis band to approximately  $V_{HB} = 100mV$  with  $V_{THR}$  and  $V_{THF}$  set to approximately 3.026V and 2.903V, respectively.

## =QUICK START PROCEDURES

### Required Equipment

- TS9004DB demo board
- A DC Power Supply, an HP Model HP6624A or equivalent
- A Precision DC Source/Calibrator, a Krohn-Hite Model 526 or equivalent
- A Digital Voltmeter
- A Digital Ammeter
- Oscilloscope Model Agilent DSO1014A or equivalent ( AC input only)
- 1M $\Omega$  oscilloscope probe ( AC input only)
- Function Generator ( AC input only)

To evaluate the TS9004 comparators, the following steps are to be performed:

- 1) Before connecting the DC power supply to the demo board power test points, turn on the power supply and set the DC voltage to 5V and then turn it off.
- 2) Set the DC source/calibrator voltage to 2.8V and turn it off.
- 3) Connect the positive terminal of the DC power supply to the  $V_{DD}$  jumper on the demo board and the negative terminal to the positive terminal of the ammeter. Then, connect the negative terminal of the ammeter to a GND jumper on the demo board.
- 4) Connect the positive terminal of the DC source/calibrator to the INB+ jumper on the demo board and the negative terminal to a GND jumper on the demo board.
- 5) Connect the positive terminal of the DC voltmeter to the OUTB jumper on the demo board and the negative terminal to a GND jumper on the demo board.
- 6) Turn on the power supply and the DC source/calibrator and check that the power supply current is approximately 6 $\mu$ A, including any currents through external resistors.
- 7) Slowly increase the DC source/calibrator voltage until the output of the comparator switches to approximately 5V. Refer to the voltmeter. The output should switch from a low state to a high state at approximately 3.026V. The power supply current is now approximately 8 $\mu$ A.
- 8) Now, slowly decrease the DC source/calibrator voltage until the output of the comparator drops to approximately 0V. Refer to the voltmeter. The output should switch from a high state to a low state at approximately 2.903V. The power supply current is approximately 6 $\mu$ A.
- 9) To measure the reference voltage, connect the positive terminal of a voltmeter to the REF jumper on the demo board and the negative terminal to a GND jumper on the demo board.

- 10) If testing with an AC input signal is desired, use a function generator and set the offset voltage, amplitude, and frequency to 3V, 400mV, and 1kHz, respectively. Connect the positive terminal of the function generator to the INB+ jumper and the negative terminal to the GND jumper on the board. Then, use the oscilloscope and the oscilloscope probe to monitor the output OUTB.
- 11) If the evaluation of comparator A is desired,

follow the previous steps. However, note that the output signal OUTA is configured to be the inverted version of comparator B's output OUTB.

- 12) Evaluation of comparator C and D can be performed on the TS9004 demo board. Access to the input and output of comparator C and D is available as shown in Figure 3.

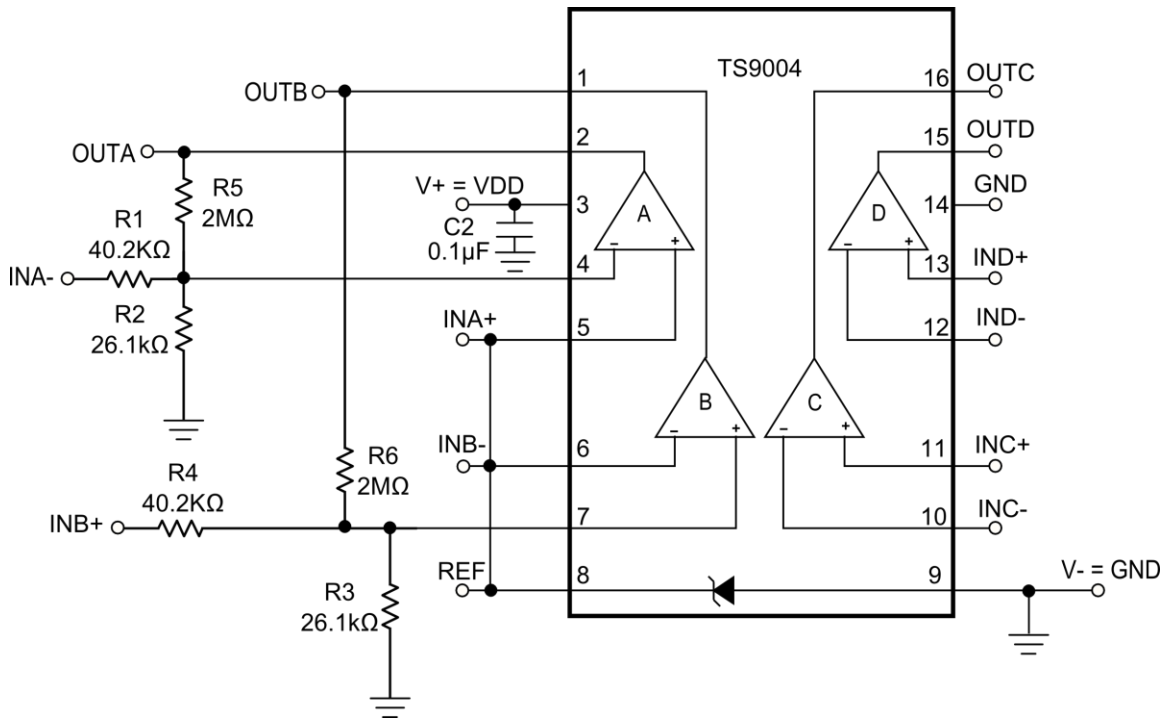

Figure 3. TS9004 Demo Board Circuit

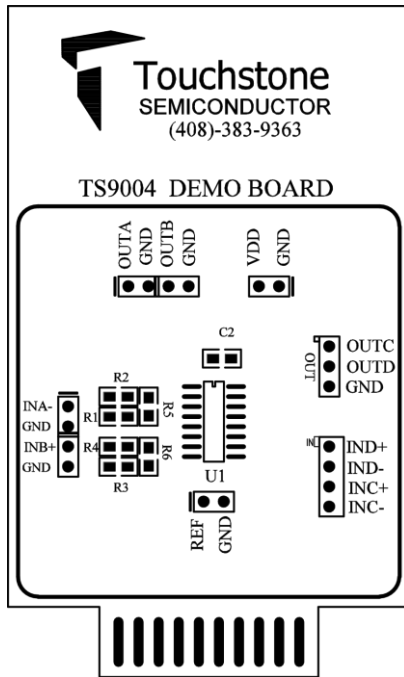

Figure 4. Top Layer Component View

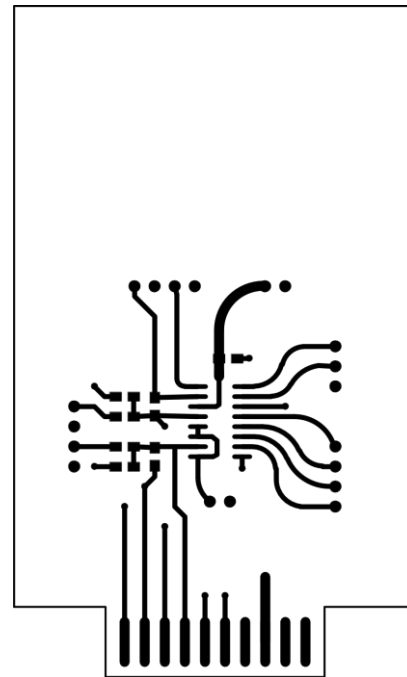

Figure 5. Top Layer Trace View

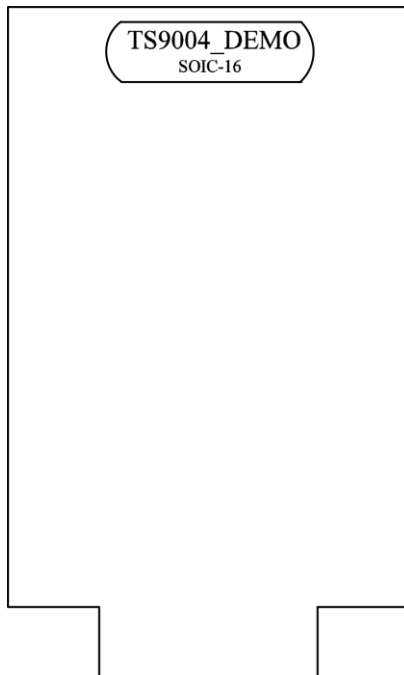

Figure 6. Bottom Layer #1

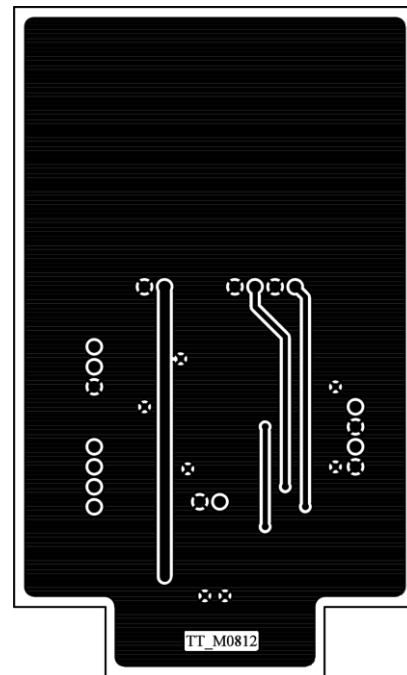

Figure 7. Bottom Layer #2

## Данный компонент на территории Российской Федерации

### Вы можете приобрести в компании MosChip.

Для оперативного оформления запроса Вам необходимо перейти по данной ссылке:

<http://moschip.ru/get-element>

Вы можете разместить у нас заказ для любого Вашего проекта, будь то серийное производство или разработка единичного прибора.

В нашем ассортименте представлены ведущие мировые производители активных и пассивных электронных компонентов.

Нашей специализацией является поставка электронной компонентной базы двойного назначения, продукции таких производителей как XILINX, Intel (ex.ALTERA), Vicor, Microchip, Texas Instruments, Analog Devices, Mini-Circuits, Amphenol, Glenair.

Сотрудничество с глобальными дистрибьюторами электронных компонентов, предоставляет возможность заказывать и получать с международных складов практически любой перечень компонентов в оптимальные для Вас сроки.

На всех этапах разработки и производства наши партнеры могут получить квалифицированную поддержку опытных инженеров.

Система менеджмента качества компании отвечает требованиям в соответствии с ГОСТ Р ИСО 9001, ГОСТ РВ 0015-002 и ЭС РД 009

### Офис по работе с юридическими лицами:

105318, г.Москва, ул.Щербаковская д.3, офис 1107, 1118, ДЦ «Щербаковский»

Телефон: +7 495 668-12-70 (многоканальный)

Факс: +7 495 668-12-70 (доб.304)

E-mail: [info@moschip.ru](mailto:info@moschip.ru)

Skype отдела продаж:

moschip.ru

moschip.ru\_4

moschip.ru\_6

moschip.ru\_9