

NB3N65027DTGEVB

NB3N65027 Evaluation Board User's Manual



ON Semiconductor®

<http://onsemi.com>

Device Name: NB3N65027DT (QSOP20)
Board Name: NB3N65027DTGEVB

EVAL BOARD USER'S MANUAL

Introduction

NB3N65027 device is a 3.3 V Programmable 3 PLL Clock Synthesizer with 6 LVTTTL / LVCMS Outputs w/OE. ON Semiconductor has developed an evaluation board NB3N65027DTGEVB for the NB3N65027 in 20L QSOP (150 mil) package. The evaluation board NB3N65027DTGEVB is offered as a convenience for the customers interested in performing their own engineering assessment on the general performance of NB3N65027.

This evaluation board manual contains:

- Information on 20L QSOP (150 mil) Evaluation Board
- Evaluation board Circuit Schematic
- Bill of Materials

This manual should be used in conjunction with the device data sheet, which contains full technical details on the device specifications and operation.

Description

Evaluation board for testing NB3N65027 in 20L QSOP (150 mil) is a 2" x 2", 4 layer board with dedicated VDD and GND planes.

The top and bottom view of the assembled Evaluation board is shown in Figure 1 and Figure 2. Top and bottom view of the bare printed circuit board (PCB) is shown in Figure 3 and Figure 4.

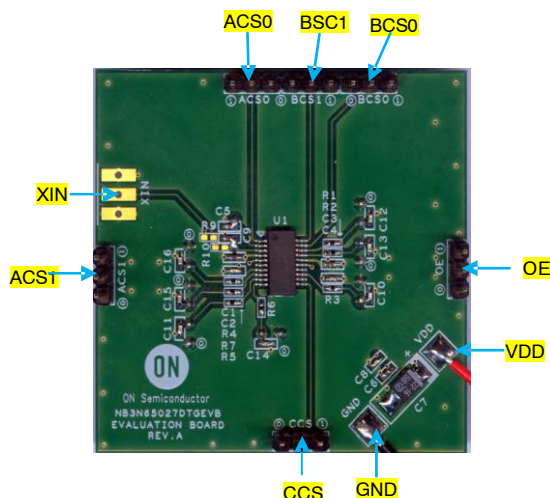

Figure 1. Evaluation Board top View

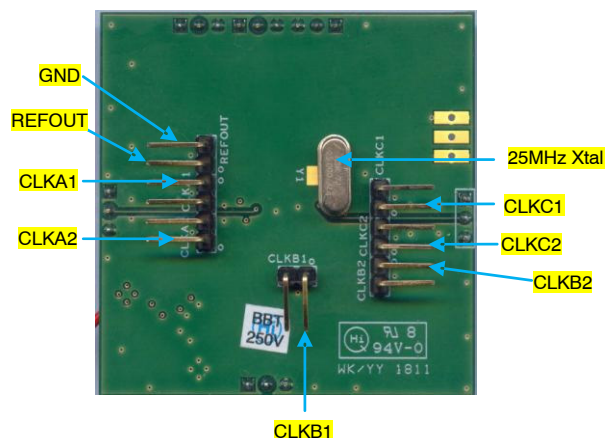

Figure 2. Evaluation Board Bottom View

NB3N65027DTGEVB

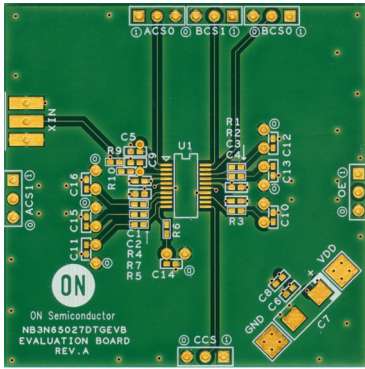

Figure 3. Evaluation Board top View (Bare PCB)

The Schematic of the Evaluation board is shown in Figure 5. The bill of material for the Evaluation board is shown in Table 1.

Test and Measurement Set-up and Procedure

Power supply is fed to the board through VDD and GND terminals. C6, C7, and C8 are the decoupling capacitors for the power supply into the board. Decoupling capacitors C1 and C2 are provided close to the device on VDD1, while C3 and C4 are provided close to device on VDD2 respectively.

Crystal Y1, capacitors C5 and C9 provide the crystal interface to the device at X1 and X2. The values of C5 and C9 are chosen based on the load capacitance (CL) of the crystal used. When Crystal interface is used, XIN, R9 and R10 are not mounted.

When crystal interface is not used, clock can be fed from an external source using XIN and R10. R9 is used for output termination of the clock source.

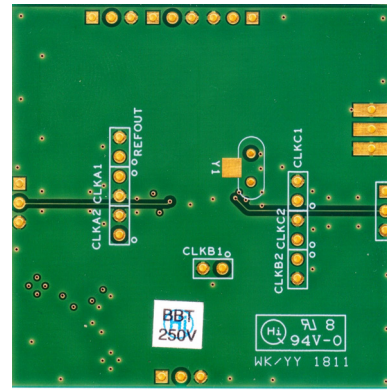

Figure 4. Evaluation Board bottom View (Bare PCB)

The state of signal Output Enable (OE) is controlled through 3-pin through hole header OE.

The state of control pins ACS0, ACS1, BCS0, BCS1 and CCS are controlled through 3-pin through hole headers of the same name. The selected states of the signals determine the output clocks on CLKA1, CLKA2, CLKB1, CLKB2, CLKC1, and CLKC2 as per the clock selection table.

Output clocks REFOUT, CLKA1, CLKA2, CLKB1, CLKB2, CLKC1, and CLKC2 can be monitored at 2-pin through hole headers REFOUT, CLKA1, CLKA2, CLKB1, CLKB2, CLKC1, and CLKC2 respectively, provided close to device.

Resistors R1 ~ R7 are the Series terminating resistors on the output clocks.

The general performance of NB3N65027 on the evaluation board can be tested using the list of instruments mentioned in the manual.

NB3N65027DTGEVB

NB3N65027DTGEVB EVALUATION BOARD SCHEMATIC

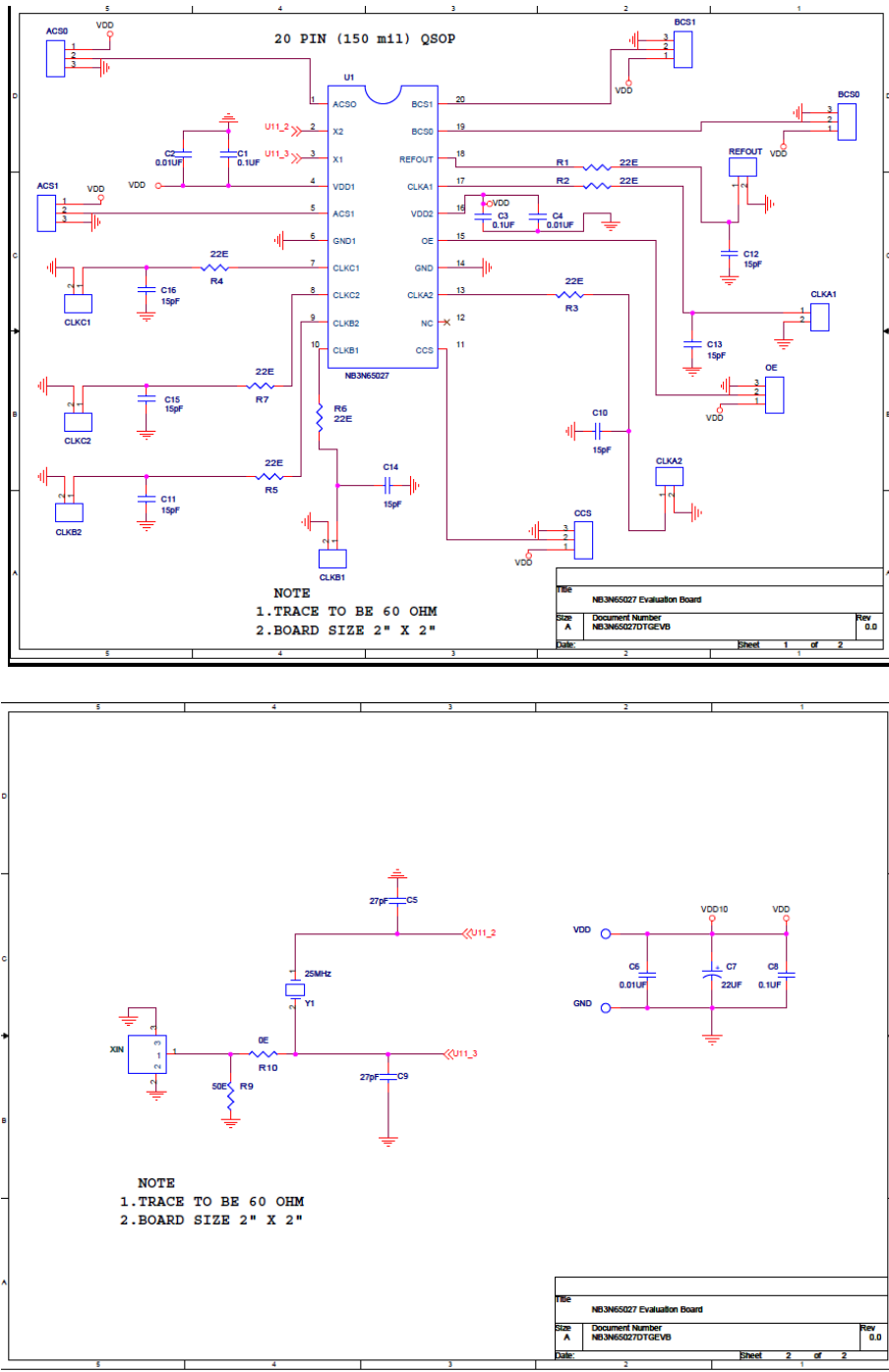

Figure 5. NB3N65027DTGEVB Evaluation Board Schematic

LIST OF INSTRUMENTS

- Signal Generator: Agilent 81110A (or equivalent)
if Input Clock is from External Source
- Oscilloscope: Tektronix TDS7704B (or equivalent)
- Probes: P7260, 6GHz single ended Active Probe
- Power Supply: Agilent 6624A DC (or equivalent)
- Digital Voltmeter: Agilent 34410A or 34401 (or equivalent)

NB3N65027DTGEVB

BILL OF MATERIAL

Table 1. NB3N65027DTGEVB EVALUATION BOARD REV. A BILL OF MATERIAL

| Item | Qty | Reference | Part | Description | Size | Vendor | Vendor Part Number |
|------|-----|--|--------------|-----------------------------------|------------------------------------|----------------------------|------------------------|
| 1 | 6 | BCS1, ACS1, OE, CCS, BCS0, ACS0 | 3 Pin Header | Through Hole HEADER | 2.54 mm | Samtec | TSW-116-11-G-S |
| 2 | 7 | CLKA1, CLKA2, CLKB1, CLKB2, CLKC1, CLKC2, REFOUT | 2 Pin Header | Through Hole HEADER | 2.54 mm | Samtec | TSW-116-11-G-S |
| 3 | 3 | C1,C3,C8 | 0.1uF | CAP 0.1 μ F 16 V 5% 0402 SMD | 0402 | Walsin | 0402B104K160CT |
| 4 | 3 | C2,C4,C6 | 0.01uF | CAP 0.01 μ F 50 V 5% 0402 SMD | 0402 | Walsin | 0402B103K500CT |
| 5 | 2 | C5,C9 | 27pF | CAP 27 pF 50 V 5% 0402 SMD | 0402 | Walsin | 0402N270J500LT |
| 6 | 1 | C7 | 22uF | CAP 22 μ F 16 V 5% 6032 SMD | 6032 | AVX | TAJC226K016R |
| 7 | 7 | C10, C11, C12, C13, C14, C15, C16 | 15pF | CAP 15 pF 50 V 5% 0402 SMD | 0402 | Walsin | 0402N150J500LT |
| 8 | | VDD,GND | | | | | |
| 9 | 7 | R1,R2,R3,R4, R5,R6,R7 | 22E | RES 22 Ω 1/16W 5% 0402 SMD | 0402 | Walsin | WR04X220JTL |
| 10 | 1 | R9 | 50E | RES 50 Ω 1/16W 5% 0402 SMD | 0402 | Walsin | WR04X500JTL |
| 11 | 1 | R10 | 0E | RES 0 Ω 1/16W 0402 SMD | 0402 | Walsin | |
| 12 | 1 | U1 | NB3N65027 | NB3N65027 20L QSOP Device | QSOP_20 | ON Semiconductor | NB3N65027DTR2G |
| 13 | 1 | XIN | SMA | 4 Pin SMA Jack | | Samtec | SMA-J-P-H-ST-TH1 |
| 14 | 1 | Y1 | Crystal | 25 MHz, 2 pin Crystal | Crystal_HC45U or UM1 or equivalent | Andhra Electronics Limited | UM12GH3G118P025M000000 |

ON Semiconductor and  are registered trademarks of Semiconductor Components Industries, LLC (SCILLC). SCILLC reserves the right to make changes without further notice to any products herein. SCILLC makes no warranty, representation or guarantee regarding the suitability of its products for any particular purpose, nor does SCILLC assume any liability arising out of the application or use of any product or circuit, and specifically disclaims any and all liability, including without limitation special, consequential or incidental damages. "Typical" parameters which may be provided in SCILLC data sheets and/or specifications can and do vary in different applications and actual performance may vary over time. All operating parameters, including "Typicals" must be validated for each customer application by customer's technical experts. SCILLC does not convey any license under its patent rights nor the rights of others. SCILLC products are not designed, intended, or authorized for use as components in systems intended for surgical implant into the body, or other applications intended to support or sustain life, or for any other application in which the failure of the SCILLC product could create a situation where personal injury or death may occur. Should Buyer purchase or use SCILLC products for any such unintended or unauthorized application, Buyer shall indemnify and hold SCILLC and its officers, employees, subsidiaries, affiliates, and distributors harmless against all claims, costs, damages, and expenses, and reasonable attorney fees arising out of, directly or indirectly, any claim of personal injury or death associated with such unintended or unauthorized use, even if such claim alleges that SCILLC was negligent regarding the design or manufacture of the part. SCILLC is an Equal Opportunity/Affirmative Action Employer. This literature is subject to all applicable copyright laws and is not for resale in any manner.

PUBLICATION ORDERING INFORMATION

LITERATURE FULFILLMENT:
 Literature Distribution Center for ON Semiconductor
 P.O. Box 5163, Denver, Colorado 80217 USA
Phone: 303-675-2175 or 800-344-3860 Toll Free USA/Canada
Fax: 303-675-2176 or 800-344-3867 Toll Free USA/Canada
Email: orderlit@onsemi.com

N. American Technical Support: 800-282-9855 Toll Free
 USA/Canada
Europe, Middle East and Africa Technical Support:
 Phone: 421 33 790 2910
Japan Customer Focus Center
 Phone: 81-3-5773-3850

ON Semiconductor Website: www.onsemi.com
Order Literature: <http://www.onsemi.com/orderlit>
 For additional information, please contact your local Sales Representative

Данный компонент на территории Российской Федерации

Вы можете приобрести в компании MosChip.

Для оперативного оформления запроса Вам необходимо перейти по данной ссылке:

<http://moschip.ru/get-element>

Вы можете разместить у нас заказ для любого Вашего проекта, будь то серийное производство или разработка единичного прибора.

В нашем ассортименте представлены ведущие мировые производители активных и пассивных электронных компонентов.

Нашей специализацией является поставка электронной компонентной базы двойного назначения, продукции таких производителей как XILINX, Intel (ex.ALTERA), Vicor, Microchip, Texas Instruments, Analog Devices, Mini-Circuits, Amphenol, Glenair.

Сотрудничество с глобальными дистрибьюторами электронных компонентов, предоставляет возможность заказывать и получать с международных складов практически любой перечень компонентов в оптимальные для Вас сроки.

На всех этапах разработки и производства наши партнеры могут получить квалифицированную поддержку опытных инженеров.

Система менеджмента качества компании отвечает требованиям в соответствии с ГОСТ Р ИСО 9001, ГОСТ РВ 0015-002 и ЭС РД 009

Офис по работе с юридическими лицами:

105318, г.Москва, ул.Щербаковская д.3, офис 1107, 1118, ДЦ «Щербаковский»

Телефон: +7 495 668-12-70 (многоканальный)

Факс: +7 495 668-12-70 (доб.304)

E-mail: info@moschip.ru

Skype отдела продаж:

moschip.ru

moschip.ru_4

moschip.ru_6

moschip.ru_9