

THIS DRAWING IS UNPUBLISHED. RELEASED FOR PUBLICATION 20
 © COPYRIGHT 20 BY - ALL RIGHTS RESERVED.

REVISIONS				
P	LTR	DESCRIPTION	DATE	APVD
	K	REV PER ECO 14-015092	10-6-14	CT PD

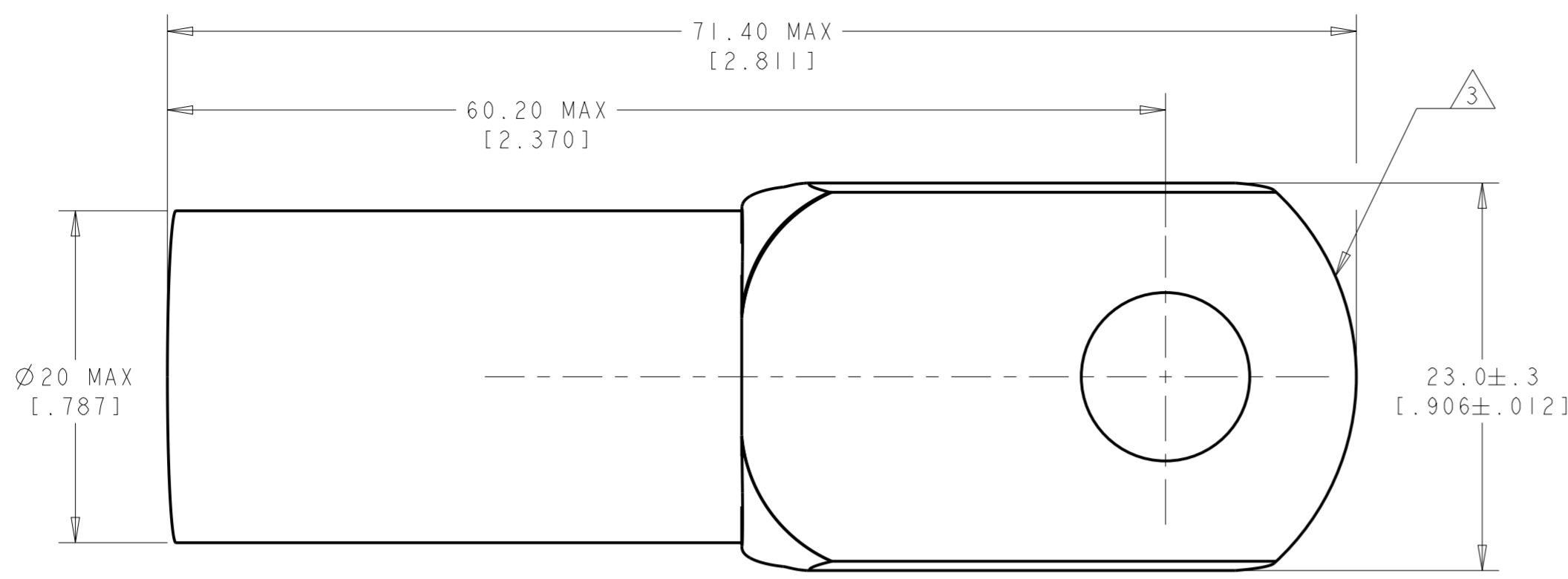

1: WIRE INSULATION : 12.7[.500]-14.0[.551]
 2: WIRE CMA: 119500 to 150500
 3: TONGUE RADIUS FEATURE IS NOT A TOOLING CONTROLLED DIMENSION AND MAY NOT BE A TRUE RADIUS

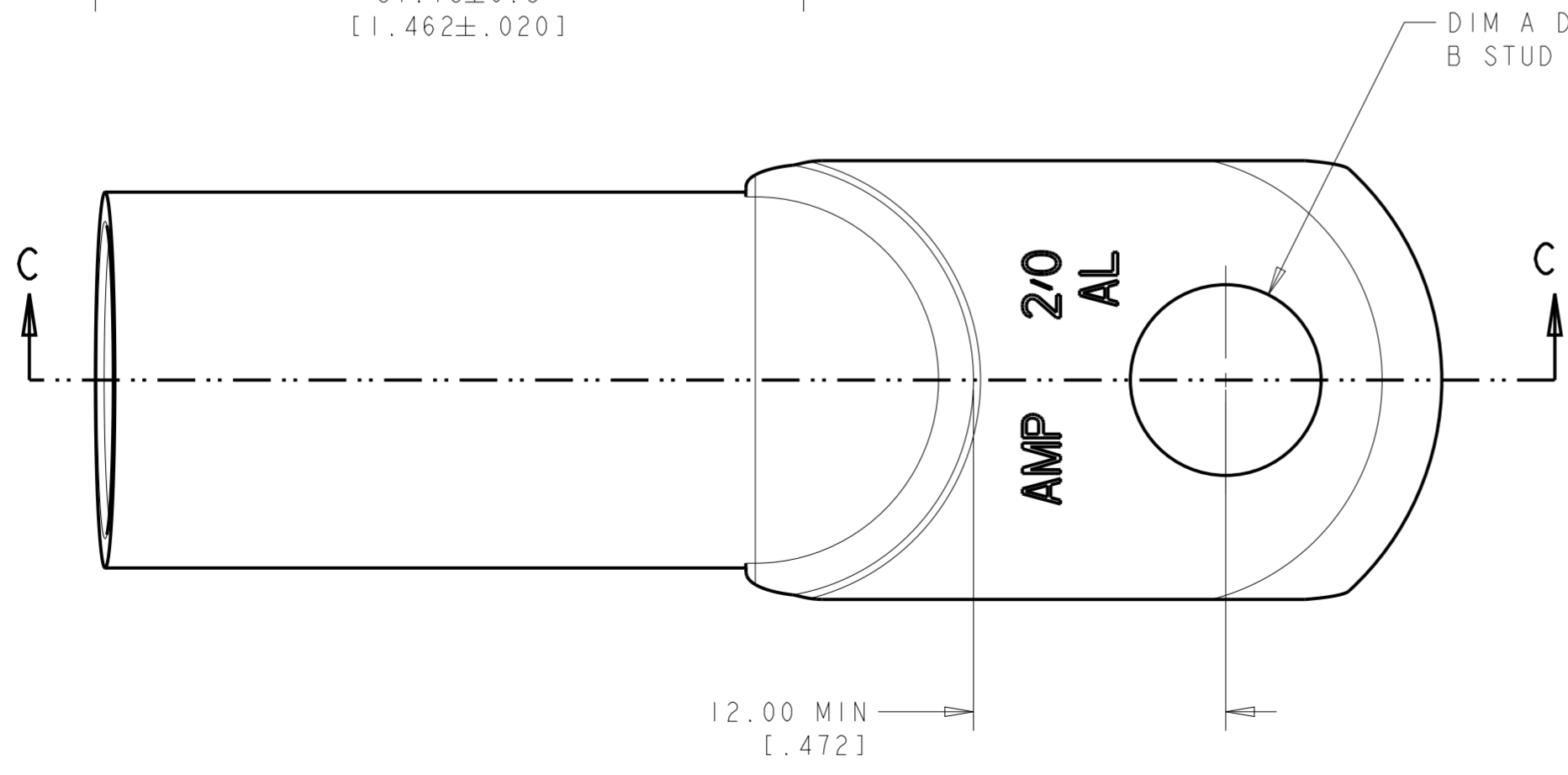
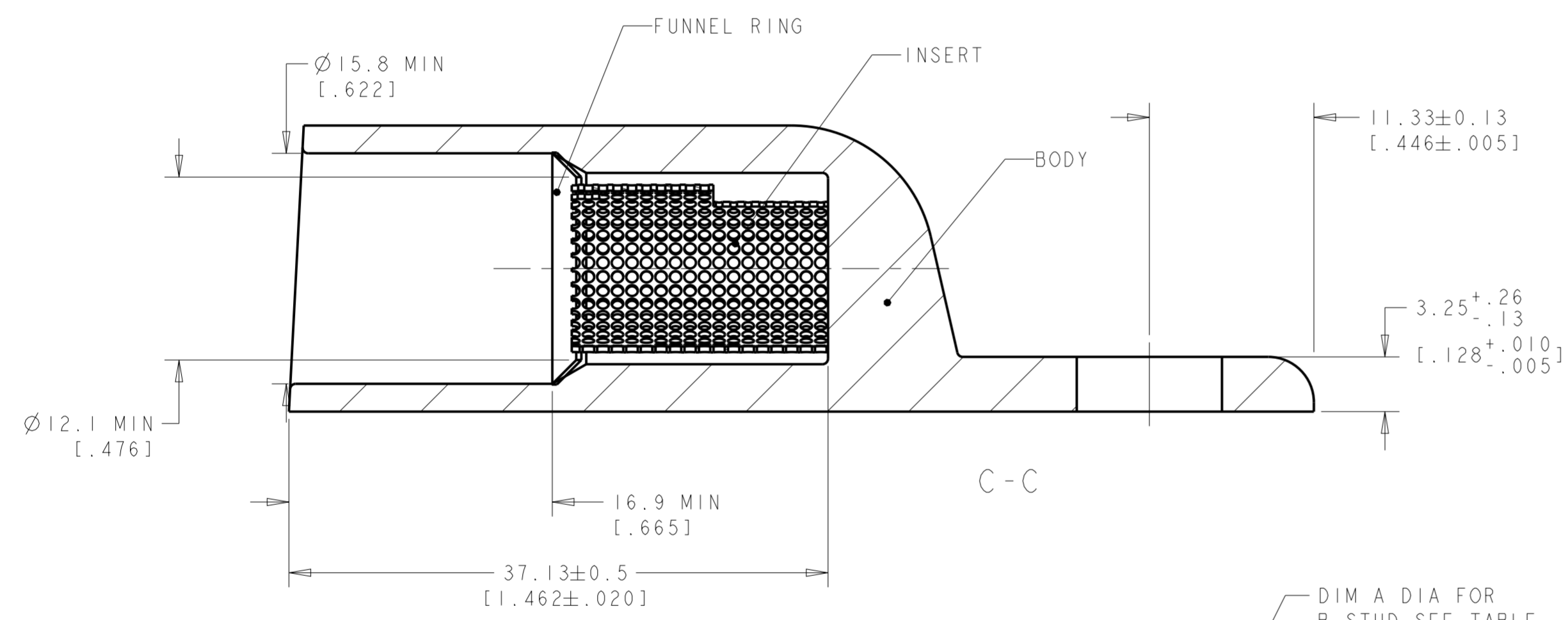

WEIGHT	DIM A	B	MATERIAL&FINISH	PART NUMBER	
80 gms	6.73+/-0.04 [.265+/-0.002]	1/4 or M6	BODY: COPPER ASTM B187 ANNEALED TIN PLATE .00381[.000150] MIN THICK PER MIL-T-10727	134594-4	OBSOLETE
79 gms	8.34±0.04 [.328±.002]	5/16 or M8	INSERT&FUNNEL: BRASS ASTM B36 NICKEL PLATE SAE AMS QQ-N-290A, DATED JULY 2000, .00254 [0.000100] MIN THICK	134594-3	
78 gms	10.04±0.04 [.395±.002]	3/8 or M10		134594-1	

THIS DRAWING IS A CONTROLLED DOCUMENT.

DWN: JJ DESPRETZ 24 JUN 2004	CHK: G-ROBERT	APVD: Y PETRONIN 24 JUN 2004	NAME: SEALED COPALUM ASSEMBLY
DIMENSIONS: mm [Inches]		TOLERANCES UNLESS OTHERWISE SPECIFIED:	SIZE: A2
0 PLC ±0.3 1 PLC ±0.3 2 PLC ±0.13 3 PLC ± 4 PLC ± ANGLES ±5 FINISH -		PRODUCT SPEC - APPLICATION SPEC - WEIGHT - CUSTOMER DRAWING	SCALE: 2:1 SHEET 1 OF 4 REV K

STE TE Connectivity

THIS DRAWING IS UNPUBLISHED. RELEASED FOR PUBLICATION 20
 © COPYRIGHT 20 BY - ALL RIGHTS RESERVED.

REVISIONS				
P	LTR	DESCRIPTION	DATE	APVD
-	-	SEE SHEET 1	-	-

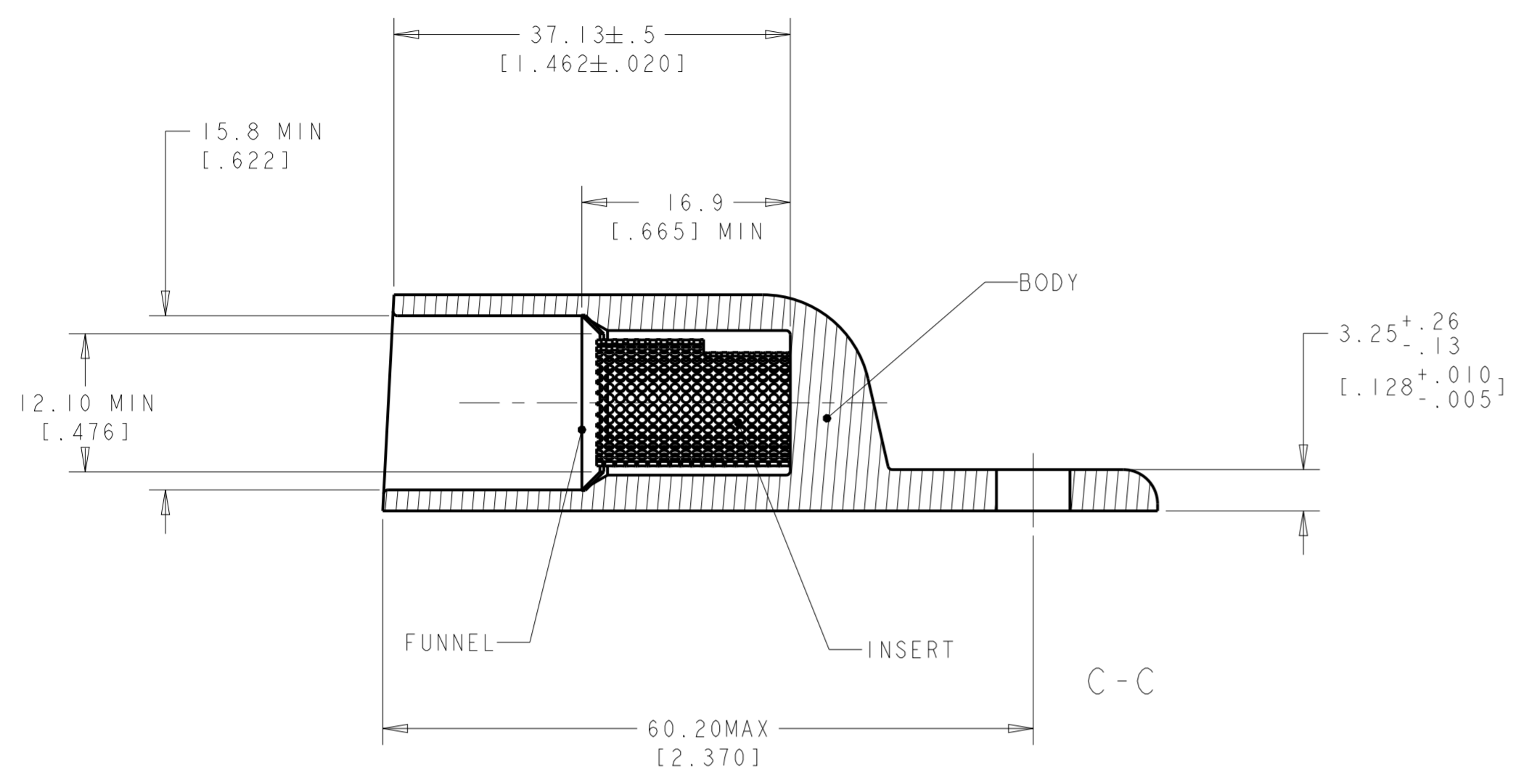

1: WIRE INSULATION :12.7[.500]-14.0[.551]
 2: WIRE CMA: 119500 to 150500
 ③; TONGUE RADIUS FEATURE IS NOT A TOOLING CONTROLLED DIMENSION AND MAY NOT BE A TRUE RADIUS

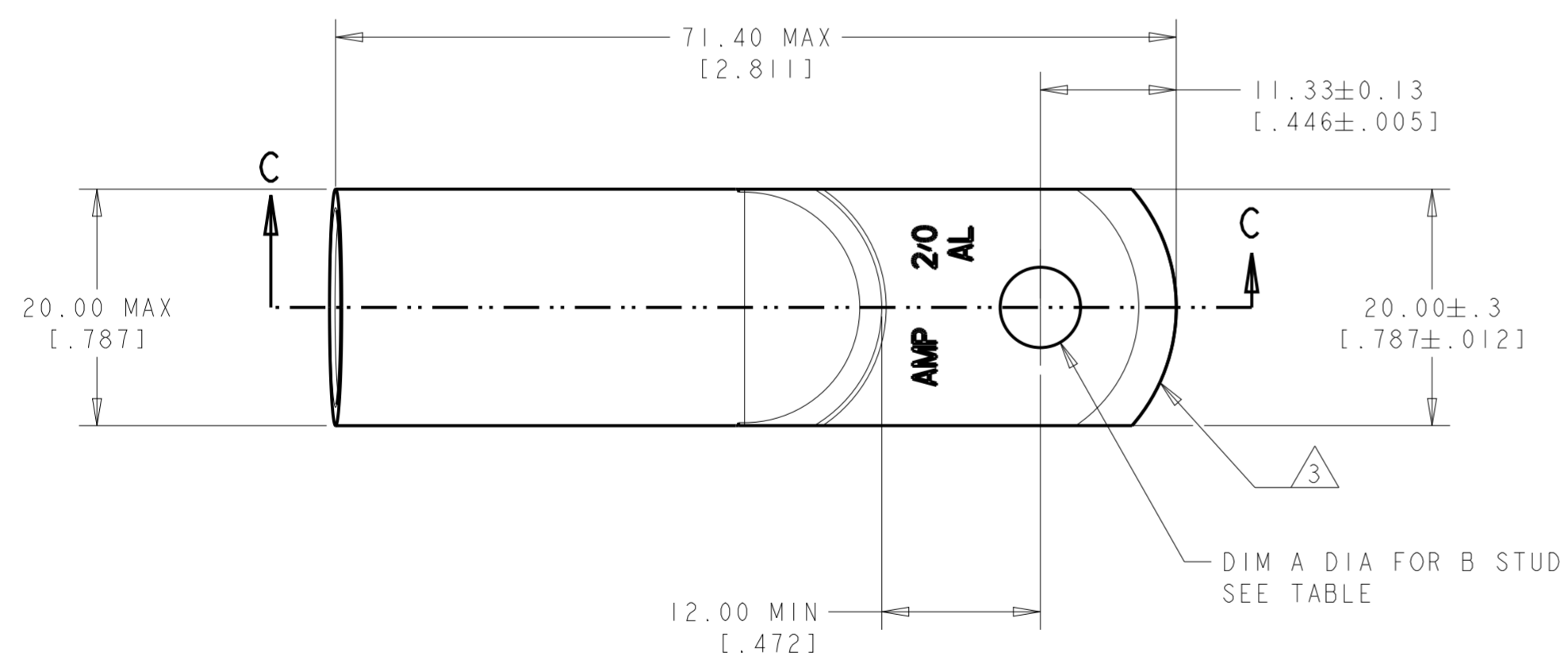

77 grams	8.34 ± 0.04 [.328 ± .002]	5/16 or M8	BODY: COPPER ASTM B187 ANNEALED TIN PLATE .00381 [.000150] MIN THICK PER MIL-T-10727	134594-6
78 grams	6.73 ± 0.04 [.265 ± .002]	1/4 or M6	INSERT&FUNNEL: BRASS ASTM B36 NICKEL PLATE SAE AMS QQ-N-290A, DATED JULY 2000, .00254 [.000100] MIN THICK	134594-2
WEIGHT	DIM A	B	MATERIAL&FINISH	PART NUMBER

THIS DRAWING IS A CONTROLLED DOCUMENT.

DWN: JJ DESPRETZ 24 JUN 2004
 CHK: G-ROBERT
 APVD: Y PETRONIN 24 JUN 2004

STE TE Connectivity

NAME: SEALED COPALUM ASSEMBLY

SIZE: A2 CAGE CODE: - DRAWING NO: 134594 RESTRICTED TO: -
 SCALE: 2:1 SHEET: 2 OF 4 REV: K

MATERIAL: - FINISH: - WEIGHT: - CUSTOMER DRAWING

TOLERANCES UNLESS OTHERWISE SPECIFIED:
 0 PLC ±0.3
 1 PLC ±0.3
 2 PLC ±0.13
 3 PLC ±
 4 PLC ±
 ANGLES ±5

THIS DRAWING IS UNPUBLISHED. RELEASED FOR PUBLICATION 20
 © COPYRIGHT 20 BY - ALL RIGHTS RESERVED.

REVISIONS				
P	LTR	DESCRIPTION	DATE	APVD
-		SEE SHEET 1	-	-

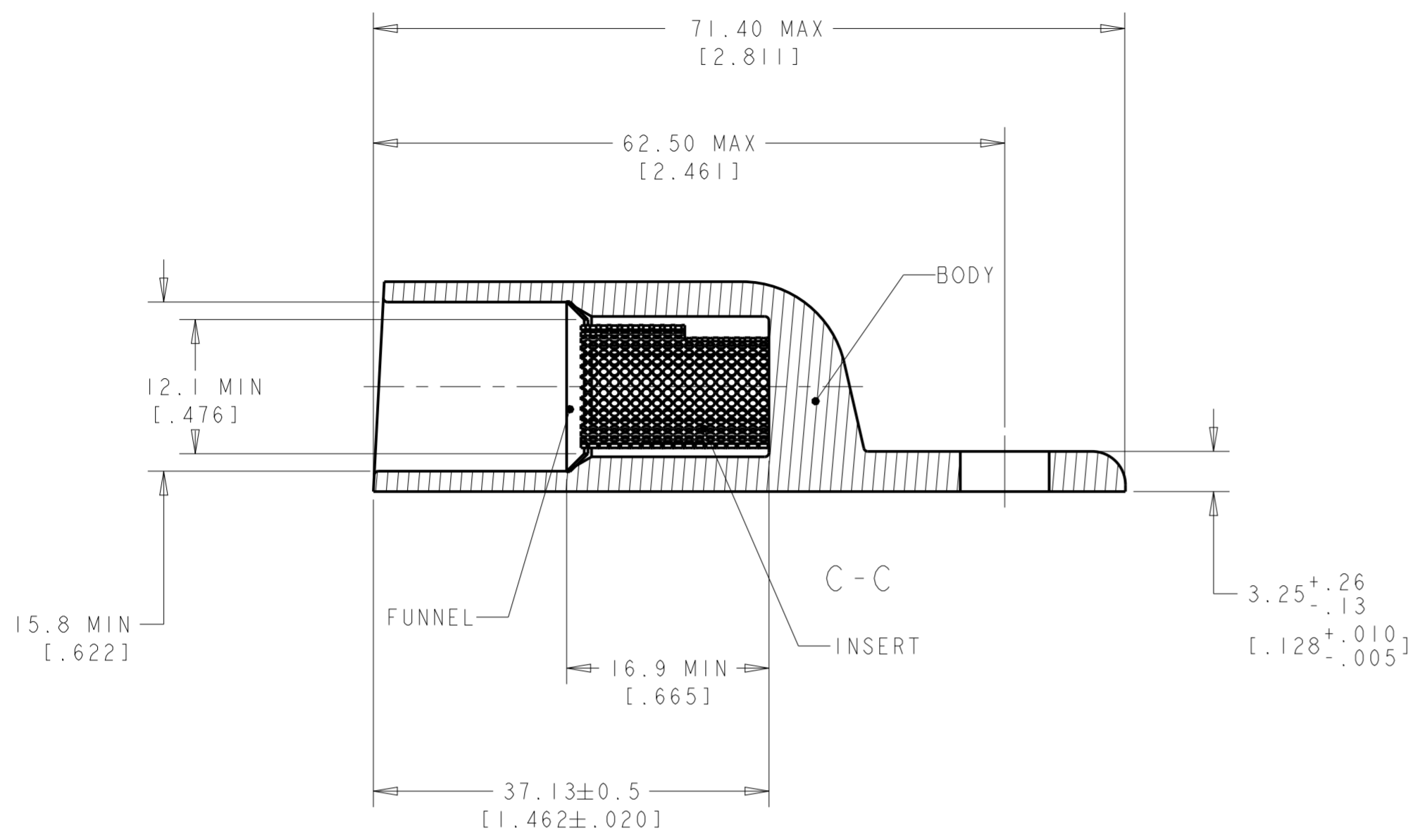

1: WIRE INSULATION : 12.7[.500]-14.0[.551]
 2: WIRE CMA: 119500 to 150500
 3: TONGUE RADIUS FEATURE IS NOT A TOOLING CONTROLLED DIMENSION AND MAY NOT BE A TRUE RADIUS

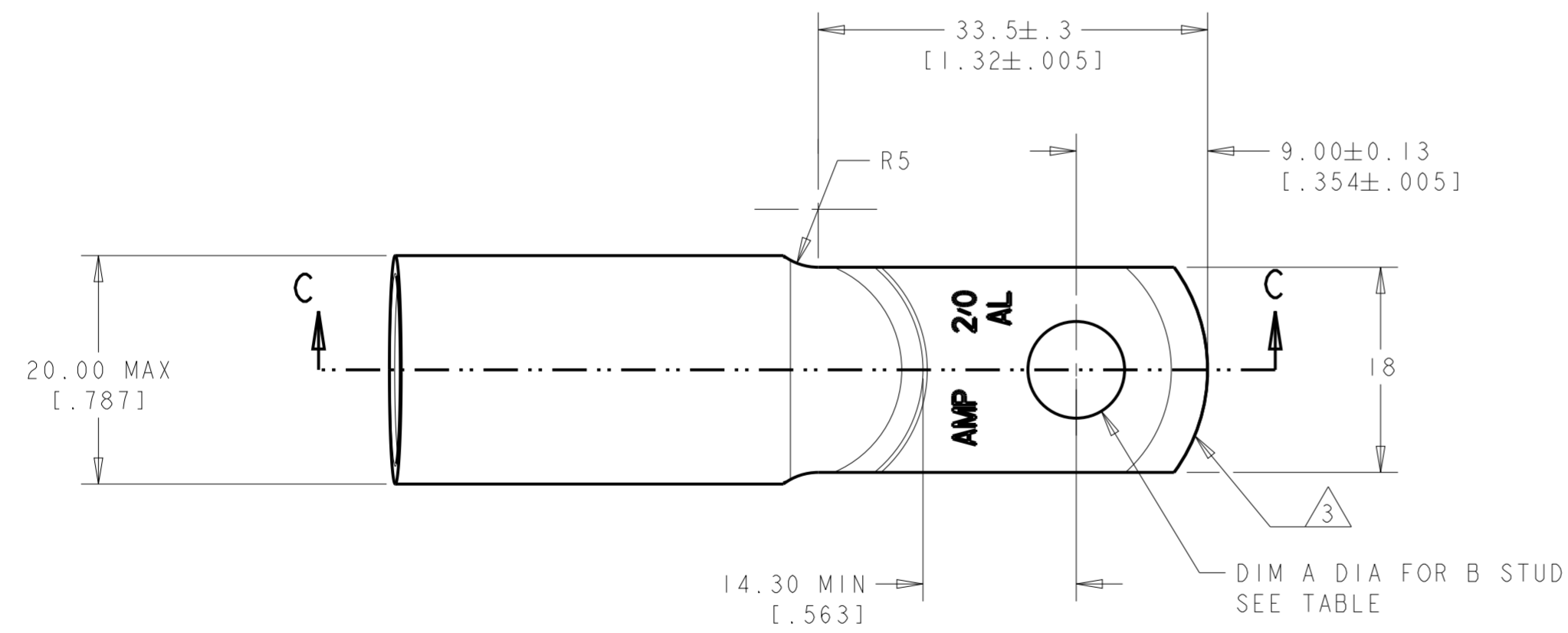

77 grams	8.34 ± 0.04 [.328 ± .002]	5/6 or M8	BODY: COPPER ASTM B187 ANNEALED TIN PLATE .00381 [.000150] MIN THICK PER MIL-T-10727 INSERT&FUNNEL: BRASS ASTM B36 NICKEL PLATE SAE AMS QQ-N-290A, DATED JULY 2000, .00254 [.000100] MIN THICK	134594-5
WEIGHT	DIM A	B	MATERIAL & FINISH	PART NUMBER

THIS DRAWING IS A CONTROLLED DOCUMENT.

DWN	24 JUN 2004	TE Connectivity	
CHK	JJ. DESPRETZ	STE	
APVD	24 JUN 2004	NAME	
	G-ROBERT	SEALED COPALUM ASSEMBLY	
	Y. PETRONIN	-	
		SIZE	RESTRICTED TO
		A2	-
		SCALE	SHEET
		2:1	3 OF 4
			REV K

CUSTOMER DRAWING

THIS DRAWING IS UNPUBLISHED. RELEASED FOR PUBLICATION 20
 © COPYRIGHT 20 BY - ALL RIGHTS RESERVED.

REVISIONS				
P	LTR	DESCRIPTION	DATE	APVD
-		SEE SHEET 1	-	-

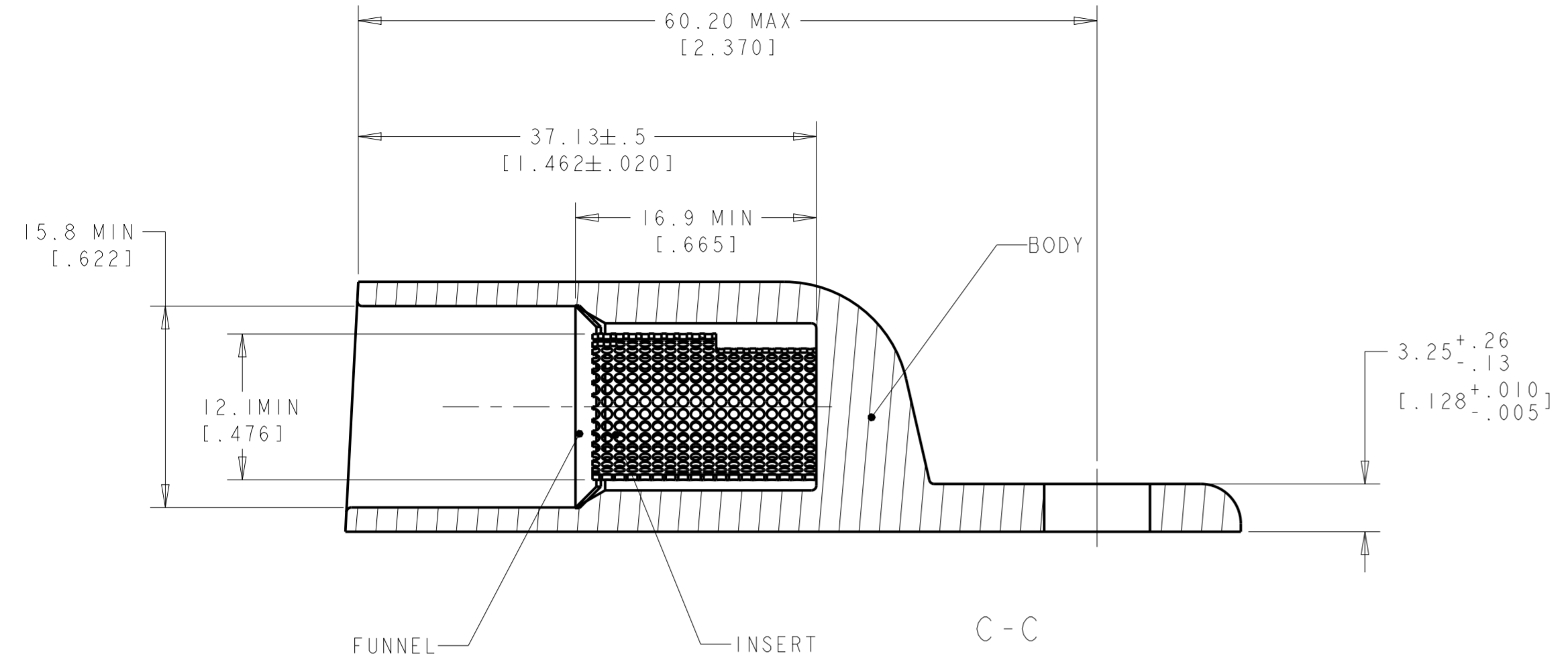

- 1: WIRE INSULATION : 12.7 [.500] - 14.0 [.551]
- 2: WIRE CMA: 119500 to 150500
- 3: TONGUE RADIUS FEATURE IS NOT A TOOLING CONTROLLED DIMENSION AND MAY NOT BE A TRUE RADIUS

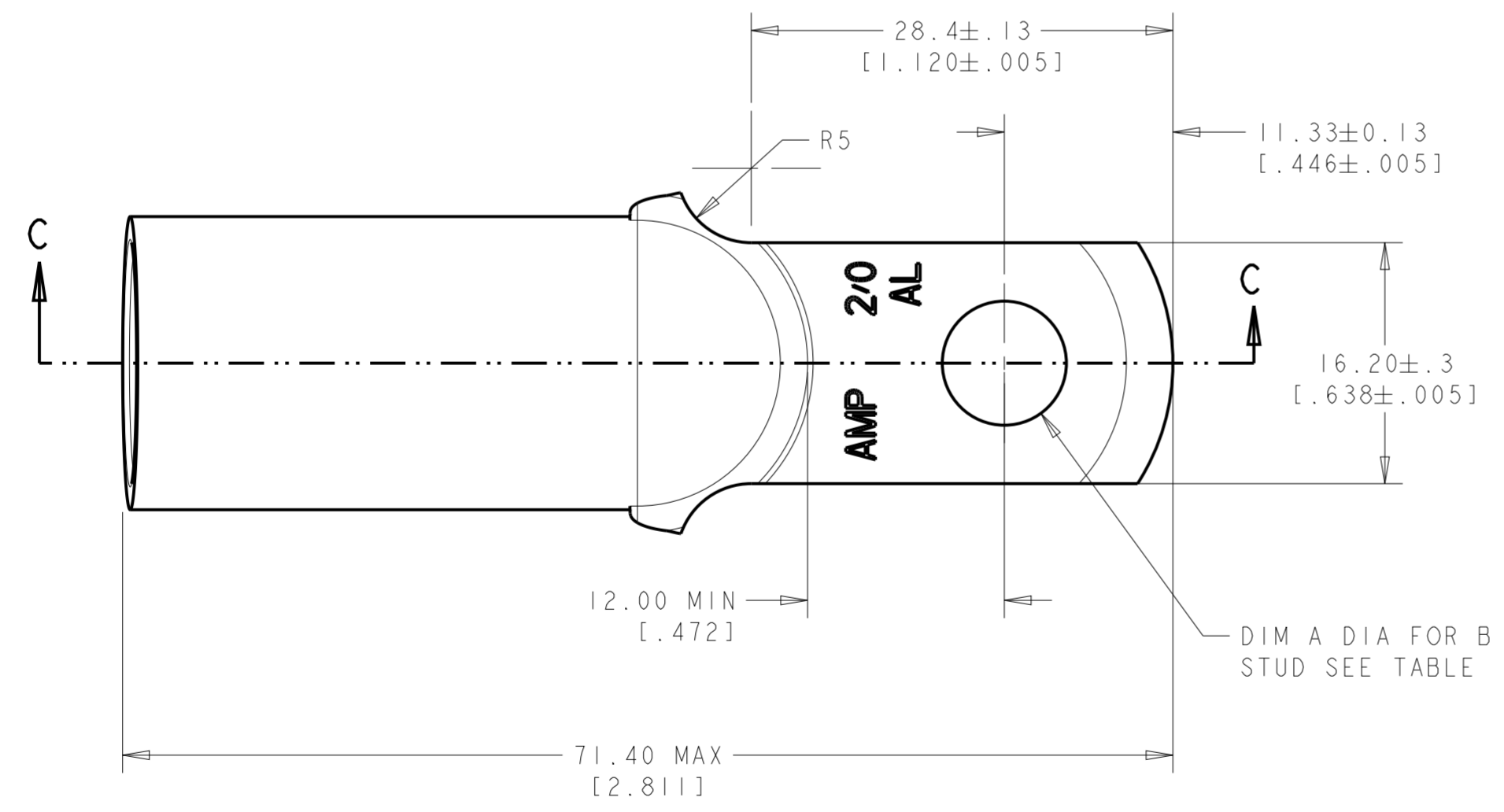

76 grams	8.34 ± 0.04 [.328 ± .002]	5/6 or M8	BODY: COPPER ASTM B187 ANNEALED TIN PLATE .00381 [.000150] MIN THICK PER MIL-T-10727 INSERT & FUNNEL: BRASS ASTM B36 NICKEL PLATE SAE AMS QQ-N-290A, DATED JULY 2000, .00254 [.000100] MIN THICK	134594-7
WEIGHT	DIM A	B	MATERIAL & FINISH	PART NUMBER

THIS DRAWING IS A CONTROLLED DOCUMENT.		DWN 24 JUN 2004 JJ. DESPRETZ	TE Connectivity	
DIMENSIONS: mm [Inches]		CHK G-ROBERT		
TOLERANCES UNLESS OTHERWISE SPECIFIED:		APVD 24 JUN 2004 Y. PETRONIN	PRODUCT SPEC -	RESTRICTED TO -
0 PLC ±0.3 1 PLC ±0.3 2 PLC ±0.13 3 PLC ± 4 PLC ± ANGLES ±5 FINISH -		APPLICATION SPEC -	SIZE A2	CAGE CODE -
MATERIAL -		WEIGHT -	DRAWING NO. C-134594	SCALE 2:1
		CUSTOMER DRAWING	SHEET 4 OF 4	REV K

Данный компонент на территории Российской Федерации

Вы можете приобрести в компании MosChip.

Для оперативного оформления запроса Вам необходимо перейти по данной ссылке:

<http://moschip.ru/get-element>

Вы можете разместить у нас заказ для любого Вашего проекта, будь то серийное производство или разработка единичного прибора.

В нашем ассортименте представлены ведущие мировые производители активных и пассивных электронных компонентов.

Нашей специализацией является поставка электронной компонентной базы двойного назначения, продукции таких производителей как XILINX, Intel (ex.ALTERA), Vicor, Microchip, Texas Instruments, Analog Devices, Mini-Circuits, Amphenol, Glenair.

Сотрудничество с глобальными дистрибьюторами электронных компонентов, предоставляет возможность заказывать и получать с международных складов практически любой перечень компонентов в оптимальные для Вас сроки.

На всех этапах разработки и производства наши партнеры могут получить квалифицированную поддержку опытных инженеров.

Система менеджмента качества компании отвечает требованиям в соответствии с ГОСТ Р ИСО 9001, ГОСТ РВ 0015-002 и ЭС РД 009

Офис по работе с юридическими лицами:

105318, г.Москва, ул.Щербаковская д.3, офис 1107, 1118, ДЦ «Щербаковский»

Телефон: +7 495 668-12-70 (многоканальный)

Факс: +7 495 668-12-70 (доб.304)

E-mail: info@moschip.ru

Skype отдела продаж:

moschip.ru

moschip.ru_4

moschip.ru_6

moschip.ru_9