

BATTERY DRIVE, 4" HIGH SPEED THERMAL PRINTER FTP-648MCL103/104, Easy Loading Method FTP-608 Series

■ OVERVIEW

The easy loading FTP-608 MCL Series is ultra compact high speed, battery driven thermal printer, printing 4-inch wide paper (114mm) where platens are removable. Our unique platen removal mechanism improved paper loading and maintenance.

The FTP-608 MCL series can be used for a variety of applications, such as portable terminals, POS, ticket issuing terminals, label printers, banking terminals, and measurement and medical equipment.



■ HIGHLIGHTS

- Easy loading type
- Our unique platen removal mechanism improved paper loading and maintenance.
- Ultra compact
- Height 20.5 mm, width 139.5mm, depth 40.5 mm for the 4 inch model.
- High speed printing
It can print at 50 mm/s (400 dotlines/s) maximum by using Fujitsu's unique head drive control.
- High resolution printing
- Label paper capability.
- RoHS compliant

■ PART NUMBERS

Item		Part Number
Printer mechanism		FTP-648MCL103 (front insertion type) with platen open detect switch FTP-648MCL104 (bottom insertion type) with platen open detect switch
LSI for driving		FTP-628CU601R
Interface board	USB	FTP-648DSL622R
	Serial	FTP-648DSL623R
Cables	USB	FTP-629Y301
	Serial	FTP-628Y302
	Power	FTP-628Y402

■ SPECIFICATIONS

Item		Specifications
Part number		FTP-648MCL103/104
Printing method		Thermal line dot method
Dot structure		832 dots/line
Dot pitch (horizontal)		0.125mm (8dots/mm) - Dot density
Dot pitch (vertical)		0.125mm (8dots/mm) - Line feed pitch
Effective printing area		104mm
Number of columns		ANK 69 columns/line (maximum 12 x 24 dot font)
Paper width	MCL103	112mm
	MCL104	114mm +0/-1
Paper thickness	MCL103	60 to 115 μ m (some paper may not be used because of characteristics)
	MCL104	60 to 150 μ m
Printing speed		Maximum 50mm/sec. (400 dot lines/sec.) 7.2V
Character types		Alphanumeric, katakana: 159 types International and special characters: 195 types OCR I: 103 types OCR III: 23 types OCR IV: 103 types Extended numeric: 11 types JIS Kanji level 1, level 2, non-Kanji: about 6,800 types
Character, dimensions (WxH), number of columns		12 x 24 dots, 69 columns: ANK 24 x 24 dots, 34 columns: ANK, Kanji 8 x 16 dots, 104 columns: ANK 16 x 16 dots, 52 columns: ANK, Kanji 24 x 40 dots, 34 columns: OCR I 24 x 48 dots, 34 columns: OCR III 36 x 60 dots, 23 columns: OCR IV 24 x 48 dots, 34 columns: Extended numeric

■ SPECIFICATIONS

Item		Specifications	
		FTP-648MCL103/104	
Interface		Conforms to RS232C / USB	
Operating Voltage	for print head	4.2 VDC to 8.5 V, average current 0.75A (2.3 A peak) Printing ratio: 12.5%, printing speed 50mm/sec., 7.2V	
	for motor	4.2VDC to 8.5V, 1A maximum	
	for logic	2.7 to 5.25 VDC, 0.2A maximum	
Dimensions	Mechanism	139.5 x 40.5 x 20.5mm (W x D x H)	
	Interface board	69 x 52 x 20mm (W x D x H)	
Weight	Mechanism	Approximately 160 g	
	Interface board	Approximately 22g	
Head life		Pulse resistance: 100 million pulses/dot (under our standard conditions). Abrasion resistance: paper traveling distance 50km (print ratio: 12.5% or less)	
Operating environment	Operating temperature*	0°C to +70°C	
	Operating humidity	20 to 85% RH (no condensation)	
	Storage	-40°C to +80°C (paper not included)	
	Storage humidity	5 to 90% RH (no condensation)	
Detection function	Head temperature detection	Detected by thermistor	
	Paper out/ mark detection	Detected by photo interruptor	
Recommended thermal sensitive paper		High sensitive paper	TF50KS-E4 (Nippon paper)
		Standard paper	TK60KS-E (Nippon paper) PD150R (Oji paper) FTP-040P0020 (114mm)
		Medium life paper	TK60KS-F1 (Nippon paper) PD170R (Oji paper) P220VBB-1 (Mitsubishi paper)
		Long life paper	PD160R-N (Oji paper) AFP-235 (Mitsubishi paper) HA220AA (Nippon paper)
		Label paper	HW54T (Nippon paper)

*+5°C to +40°C printing density assurance range (0 to 50°C capability)

■ FUNCTION

	Item		Item
1.	Test print function	8.	Motor power saving function
2.	Paper out detection	9.	Mark detection function
3.	Paper near end detection	10.	MCU operation abnormality detection
4.	Platen open detect	11.	Power ON/OFF sequence protection
5.	Thermal head temperature abnormality detection	12.	Motor over-current protection
6.	Blow-out fuse detection	13.	Hardware timer
7.	Head voltage abnormality detection		

■ DIMENSIONS

1. Printer mechanism: 4 inch

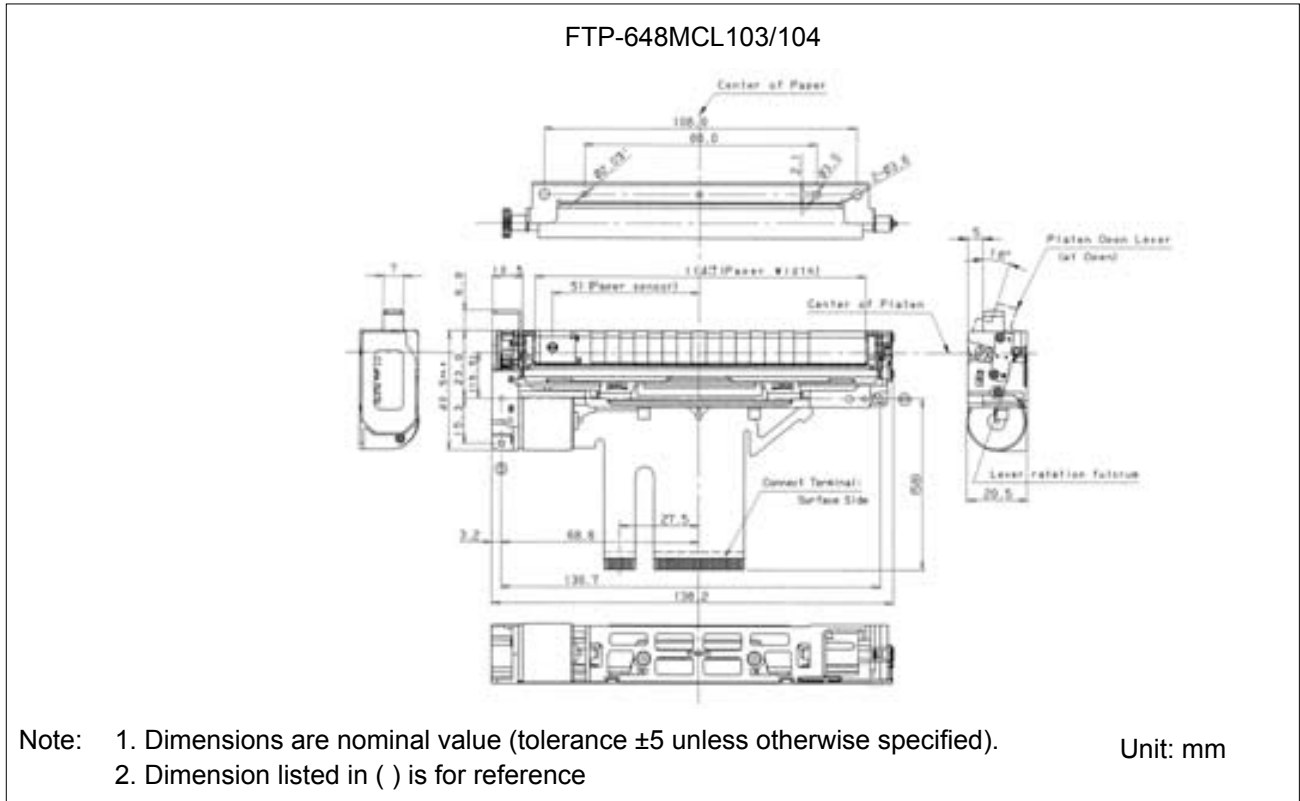

2. Interface board

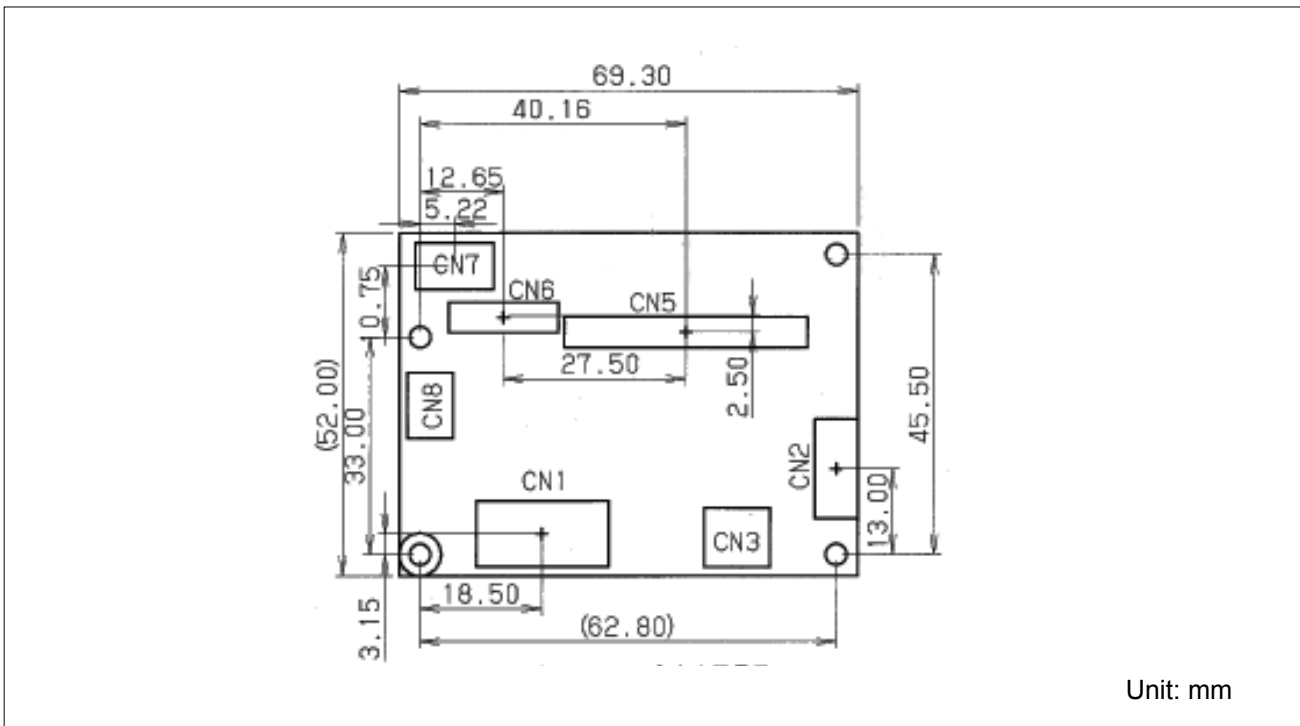

FTP-648 MCL103/104

1. Thermal head, control circuit side connector:

CN1: 52610-3071 (Molex)

CN2: 52610-1071 (Molex)

2. Pin assignment (flexible) of the printer mechanical side:

CN1: the platen release switch side is defined as No. 1

CN2: the motor excitation signal side is defined as No. 1 (31)

No	Signal	Contents
1	SW	Platen open switch
2	SW	Platen open switch
3	VH	Head drive power
4	VH	Head drive power
5	VH	Head drive power
6	DI	Data in
7	STB 7	Strobe 7
8	STB 6	Strobe 6
9	STB 5	Strobe 5
10	STB 4	Strobe 4
11	AE02	
12	AE01	
13	L-GND	Logic ground
14	GND	Head ground
15	GND	Head ground
16	GND	Head ground
17	GND	Head ground
18	GND	Head ground
19	TM	Head thermistor
20	TM	Head thermistor
21	STB 3	Strobe 3
22	STB 2	Strobe 2
23	STB 1	Strobe 1
24	Vdd	Logic power
25	CLK	Clock
26	LAT	Data latch
27	DO	Data out
28	VH	Head drive power
29	VH	Head drive power
30	VH	Head drive power

No	Signal	Contents
31	PHK	Cathode
32	VSEN	Paper sensor power
33	PHE	Emitter
34	MT A	Excitation signal A
35	MT \bar{A}	Excitation signal \bar{A}
36	MT B	Excitation signal B
37	MT \bar{B}	Excitation signal \bar{B}
38	TM	Motor thermistor
39	TM	Motor thermistor
40	NC	Not connected

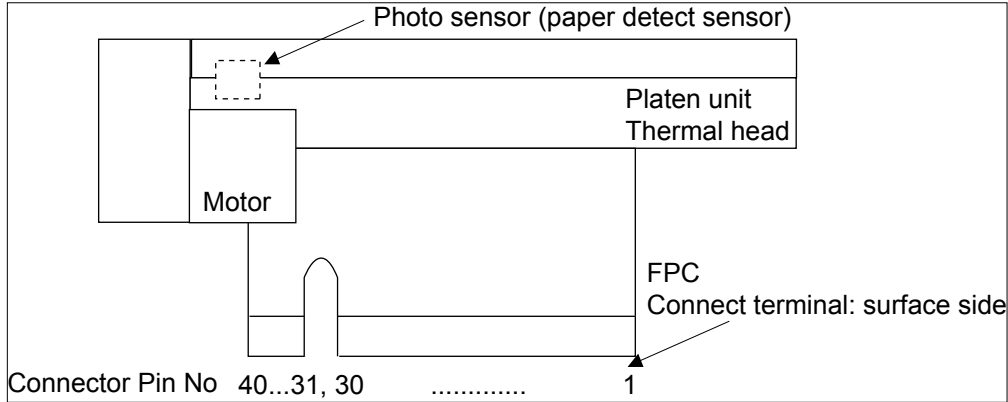

Fujitsu Components International Headquarter Offices

Japan

Fujitsu Component Limited
 Gotanda-Chuo Building
 3-5, Higashigotanda 2-chome, Shinagawa-ku
 Tokyo 141 8630, Japan
 Tel: (81-3) 5449-7010
 Fax: (81-3) 5449-2626
 Email: promothq@fcl.fujitsu.com
 Web: www.fcl.fujitsu.com

North and South America

Fujitsu Components America, Inc.
 250 E. Caribbean Drive
 Sunnyvale, CA 94089 U.S.A.
 Tel: (1-408) 745-4900
 Fax: (1-408) 745-4970
 Email: components@us.fujitsu.com
 Web: <http://us.fujitsu.com/components/>

Europe

Fujitsu Components Europe B.V.
 Diamantlaan 25
 2132 WV Hoofddorp
 Netherlands
 Tel: (31-23) 5560910
 Fax: (31-23) 5560950
 Email: info@fceu.fujitsu.com
 Web: emea.fujitsu.com/components/

Asia Pacific

Fujitsu Components Asia Ltd.
 102E Pasir Panjang Road
 #01-01 Citilink Warehouse Complex
 Singapore 118529
 Tel: (65) 6375-8560
 Fax: (65) 6273-3021
 Email: fcal@fcal.fujitsu.com
 Web: <http://www.fujitsu.com/sg/services/micro/components/>

©2009 Fujitsu Components America, Inc. All rights reserved. All trademarks or registered trademarks are the property of their respective owners.

Fujitsu Components America or its affiliates do not warrant that the content of datasheet is error free. In a continuing effort to improve our products Fujitsu Components America, Inc. or its affiliates reserve the right to change specifications/datasheets without prior notice.

Rev. February 27, 2009.

Данный компонент на территории Российской Федерации

Вы можете приобрести в компании MosChip.

Для оперативного оформления запроса Вам необходимо перейти по данной ссылке:

<http://moschip.ru/get-element>

Вы можете разместить у нас заказ для любого Вашего проекта, будь то серийное производство или разработка единичного прибора.

В нашем ассортименте представлены ведущие мировые производители активных и пассивных электронных компонентов.

Нашей специализацией является поставка электронной компонентной базы двойного назначения, продукции таких производителей как XILINX, Intel (ex.ALTERA), Vicor, Microchip, Texas Instruments, Analog Devices, Mini-Circuits, Amphenol, Glenair.

Сотрудничество с глобальными дистрибьюторами электронных компонентов, предоставляет возможность заказывать и получать с международных складов практически любой перечень компонентов в оптимальные для Вас сроки.

На всех этапах разработки и производства наши партнеры могут получить квалифицированную поддержку опытных инженеров.

Система менеджмента качества компании отвечает требованиям в соответствии с ГОСТ Р ИСО 9001, ГОСТ РВ 0015-002 и ЭС РД 009

Офис по работе с юридическими лицами:

105318, г.Москва, ул.Щербаковская д.3, офис 1107, 1118, ДЦ «Щербаковский»

Телефон: +7 495 668-12-70 (многоканальный)

Факс: +7 495 668-12-70 (доб.304)

E-mail: info@moschip.ru

Skype отдела продаж:

moschip.ru

moschip.ru_4

moschip.ru_6

moschip.ru_9