

AXL F BK PN

Axioline F bus coupler for PROFINET

Data sheet
105731_en_04

© PHOENIX CONTACT 2016-01-04



1 Description

The bus coupler links a PROFINET network with the Axioline F system.

You can connect up to 63 Axioline F devices to an existing PROFINET system with the help of the bus coupler.

PROFINET features

- 2 Ethernet ports (with integrated switch)
- PROFI-safe support
- PROFINET RT and IRT
- Minimum cycle time of PROFINET for RT and IRT is 250 μ s
- Firmware can be updated
- MRP-Client
- Web-based management
- I&M 1-4
- Shared device

Features of Axioline F

- Up to 63 additional Axioline F devices can be connected
- Runtime in the bus coupler is negligible (goes to 0 μ s)
- Typical cycle time of the Axioline F local bus is around 10 μ s
- Diagnostic and status indicators



This data sheet is only valid in association with the UM EN AXL F SYS INST user manual.
For information on PROFINET basics, please refer to the UM EN PROFINET SYS user manual.



Make sure you always use the latest documentation.
It can be downloaded from the product at phoenixcontact.net/products.
Here you will also find the current GSDML file.

2	Table of contents	
1	Description	1
2	Table of contents	2
3	Ordering data	3
4	Technical data	4
5	Internal circuit diagram	7
6	Connecting PROFINET and supply	8
	6.1 Connecting PROFINET	8
	6.2 Connecting the supply voltage - terminal point assignment.....	8
7	Connection example.....	8
8	Local status and diagnostic indicators	9
9	Diagnostic indicators for PROFINET	11
10	Diagnostic status register	12
11	Diagnostic alarms	13
12	Startup.....	13
13	Service interface.....	14
14	Parameterization	15
15	Device replacement.....	15
16	Phoenix Redundancy Layer (PRL)	15
17	Dynamic configuration on the local bus	15
18	Substitute value behavior	15
19	Simple Network Management Protocol - SNMP	15
20	WBM - Web-based management	16
21	Firmware update.....	16

3 Ordering data

Description	Type	Order No.	Pcs./Pkt.
Axioline F bus coupler for PROFINET (including bus base module and connector)	AXL F BK PN	2701815	1
Accessories			
Axioline F bus base module for housing type BK (Replacement item)	AXL BS BK	2701422	5
Axioline F short power connector (for e.g., AXL F BK ...) (Replacement item)	AXL CN S/UL	2701421	5
RJ45 connector, shielded, with bend protection sleeve, 2 pieces, gray for straight cables, for assembly on site. For connections that are not crossed, it is recommended that you use the connector set with gray bend protection sleeve. (Connector/Adapter)	FL PLUG RJ45 GR/2	2744856	1
RJ45 connector, shielded, with bend protection sleeve, 2 pieces, green for crossed cables, for assembly on site. For connections that are crossed, it is recommended that the connector set with green bend protection sleeves is used. (Connector/Adapter)	FL PLUG RJ45 GN/2	2744571	1
Crimping pliers, for assembling the RJ45 plugs FL PLUG RJ45..., for assembly on site (Tools)	FL CRIMPTOOL	2744869	1
Zack marker strip for Axioline F (device labeling), in 2 x 20.3 mm pitch, unprinted, 25-section, for individual labeling with B-STIFT 0.8, X-PEN, or CMS-P1-PLOTTER (Marking)	ZB 20,3 AXL UNPRINTED	0829579	25
Zack marker strip, flat, in 10 mm pitch, unprinted, 10-section, for individual labeling with M-PEN 0.8, X-PEN, or CMS-P1-PLOTTER (Marking)	ZBF 10/5,8 AXL UNPRINTED	0829580	50
Insert label, Roll, white, unlabeled, can be labeled with: THERMOMARK ROLL, THERMOMARK ROLL X1, THERMOMARK X, THERMOMARK S1.1, Mounting type: snapped into marker carrier, Lettering field: 35 x 18.7 mm (Marking)	EMT (35X18,7)R	0801831	1
Documentation			
User manual, English, Axioline F: System and installation	UM EN AXL F SYS INST	-	-
User manual, English, Axioline F: Diagnostic registers, and error messages	UM EN AXL F SYS DIAG	-	-
Application note, English, Handling an Axioline station under Startup+	UM QS EN STARTUP+	-	-
Application note, English, Updating the firmware of an Axioline F bus coupler	AH EN TFTP FIRMWARE UPDATE AXL F BK	-	-

4 Technical data

Dimensions (nominal sizes in mm)

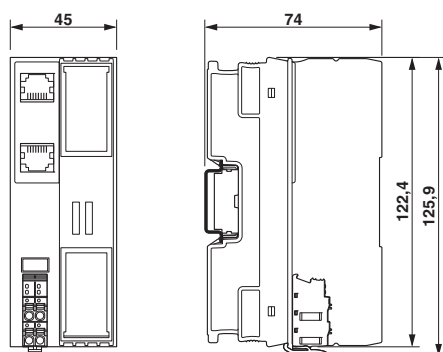

Width	45 mm
Height	125.9 mm
Depth	74 mm
Note on dimensions	The depth is valid when a TH 35-7.5 DIN rail is used (according to EN 60715).

General data

Color	traffic grey A RAL 7042
Weight	177 g (with connector and bus base module)
Ambient temperature (operation)	-25 °C ... 60 °C (Mounting position: wall mounting on horizontal DIN rail) -25 °C ... 55 °C (Mounting position: any)
Ambient temperature (storage/transport)	-40 °C ... 85 °C
Permissible humidity (operation)	5 % ... 95 % (non-condensing)
Permissible humidity (storage/transport)	5 % ... 95 % (non-condensing)
Air pressure (operation)	70 kPa ... 106 kPa (up to 3000 m above sea level)
Air pressure (storage/transport)	70 kPa ... 106 kPa (up to 3000 m above sea level)
Degree of protection	IP20
Protection class	III, IEC 61140, EN 61140, VDE 0140-1
Mounting position	Any (observe temperature derating)

Connection data

Designation	Axioline F connector
Connection method	Push-in connection
Conductor cross section solid / stranded	0.2 mm ² ... 1.5 mm ² / 0.2 mm ² ... 1.5 mm ²
Conductor cross section [AWG]	24 ... 16
Stripping length	8 mm



Please observe the information provided on conductor cross sections in the "Axioline F: system and installation" user manual.

Interface PROFINET

Number	2
Connection method	RJ45 socket, auto negotiation and auto crossing
Transmission speed	100 MBit/s (Full duplex)
Transmission physics	Ethernet in RJ45 twisted pair
Transmission length	max. 100 m

Interface Axioline F local bus

Connection method	Bus base module
Transmission speed	100 MBit/s

Interface Service

Number	1
Connection method	Micro USB type B

System limits

Number of supported devices	max. 63 (per station)
-----------------------------	-----------------------



NOTE: Electronics may be damaged when overloaded

Observe the logic current consumption of each device when configuring an Axioline F station. It is specified in every module-specific data sheet. The current consumption can differ depending on the individual module. The permissible number of devices that can be connected therefore depends on the specific station structure.

PROFINET

Device function	PROFINET device
-----------------	-----------------

Protocols supported

Protocols supported	PROFINET, FTP, TFTP, PTCP, LLDP, SNMP, MRP, DDI, Boot P
---------------------	---

Supply of the bus coupler

Supply of communications power U_L	24 V DC
Maximum permissible voltage range	19.2 V DC ... 30 V DC (including all tolerances, including ripple)
Current supply at U_{Bus}	2 A
Current consumption from U_L	typ. 105 mA (without I/Os and $U_L = 24$ V) max. 570 mA (with 2 A at U_{Bus} for the I/Os and $U_L = 24$ V)
Power consumption at U_L	typ. 2.5 W (without I/Os) max. 13.7 W (with 2 A load at U_{Bus} for the I/Os)



NOTE: Electronics may be damaged when overloaded

Provide external fuses for the 24 V U_L area. The power supply unit must be able to supply four times the nominal current of the external fuse to ensure that it blows in the event of an error.

Digital inputs

Connection method	Push-in connection
Input voltage range "0" signal	
Input voltage range "1" signal	

Error messages to the higher level control or computer system

None

Mechanical tests

Vibration resistance in acc. with EN 60068-2-6/IEC 60068-2-6	5g
Shock in acc. with EN 60068-2-27/IEC 60068-2-27	30g
Continuous shock according to EN 60068-2-27/IEC 60068-2-27	10g

Conformance with EMC Directive 2004/108/EC

Noise immunity test in accordance with EN 61000-6-2

Electrostatic discharge (ESD) EN 61000-4-2/IEC 61000-4-2	Criterion B, 6 kV contact discharge, 8 kV air discharge
Electromagnetic fields EN 61000-4-3/IEC 61000-4-3	Criterion A; Field intensity: 10 V/m
Fast transients (burst) EN 61000-4-4/IEC 61000-4-4	Criterion B, 2 kV
Transient overvoltage (surge) EN 61000-4-5/IEC 61000-4-5	Criterion B, DC supply lines: ± 0.5 kV/ ± 0.5 kV (symmetrical/asymmetrical), field-bus cable shield: ± 1 kV

Conformance with EMC Directive 2004/108/EC

Conducted interference EN 61000-4-6/IEC 61000-4-6

Criterion A; Test voltage 10 V

Noise emission test according to EN 61000-6-3

Radio interference properties EN 55022

Class B

ApprovalsFor the latest approvals, please visit phoenixcontact.net/products.

5 Internal circuit diagram

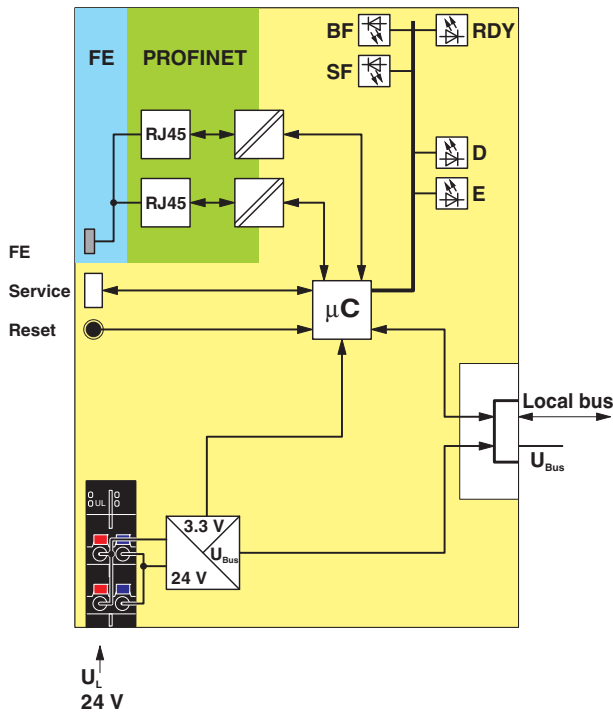

Key:

- FE Functional earth ground
- Service Service interface
- Reset Reset button
- Local bus Axioline F local bus
(hereinafter referred to as local bus)
- RJ45 RJ45 interface
- Power supply unit with electrical isolation
- Microcontroller
- Power supply unit
- LED
- Electrically isolated area

Figure 1 Internal wiring of the terminal points

6 Connecting PROFINET and supply

6.1 Connecting PROFINET

Connect PROFINET to the bus coupler via an 8-pos. RJ45 connector.

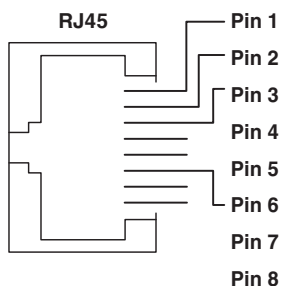

Figure 2 Pin assignment of the Ethernet socket (RJ45)

Only one twisted pair cable with an impedance of 100 Ω may be connected to each Ethernet interface in RJ45 format. The data transmission speed is 100 Mbps. The 100Base-TX port of the bus coupler is able to detect a pair of incorrectly connected receive cables (RD+/RD-) and to correct them using the auto polarity correction function.

For the pin assignment, please refer to the following table:

Pin	Assignment
1	TxD + (transmit data +)
2	TxD - (transmit data -)
3	RxD+ (receive data +)
4	Reserved
5	Reserved
6	RxD- (receive data -)
7	Reserved
8	Reserved



Auto crossover
Both Ethernet interfaces are provided with the auto crossover function.



Shielding
The shielding ground of the connected twisted pair cables is electrically connected with the socket. When connecting network segments, avoid ground loops, potential transfers, and voltage equalization currents via the braided shield.



Observe bending radii
The housing dimensions specified under "Dimensions" refer to the bus coupler with I/O connectors without Ethernet connection. When installing the bus coupler in a control box, observe the bending radii of the Ethernet cables and the connectors used (e.g., FL CAT5 FLEX: 30 mm for fixed installation and FL CAT5 HEAVY: 30 mm without outer sheath and 45 mm with outer sheath). If required, use angled RJ45 connectors to maintain these bending radii.

6.2 Connecting the supply voltage - terminal point assignment

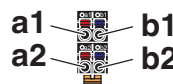

Figure 3 Terminal point assignment

Terminal point	Color	Assignment
Supply voltage input		
a1, a2	Red	24 V DC (U _L) Supply of the logic voltage (internally jumpered)
b1, b2	Blue	GND Reference potential of the supply voltage (internally jumpered)

7 Connection example

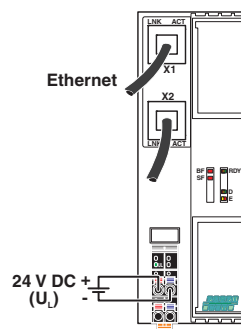

Figure 4 Connection of the cables

8 Local status and diagnostic indicators

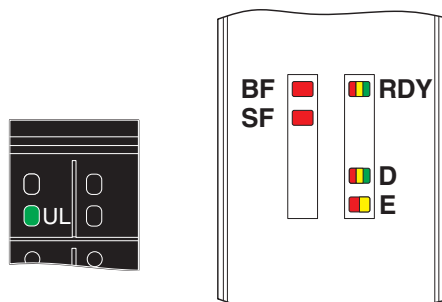

Figure 5 Local status and diagnostic indicators

Designation	Color	Meaning	State	Description
UL	Green	U _{Logic}	ON	Communications power supply present.
			OFF	Communications power supply not present.
BF	Red	Communica- tion error (B us- F ail)	ON	No link status available on any port
			Flashing	SF LED not flashing: Link status available, no communication connection to the PROFINET controller
			Flashing	SF flashing: Hardware watchdog triggered
			OFF	A PROFINET controller has established an active communication connection to the PROFINET device.
SF	Red	System failure (PROFINET)	ON	PROFINET diagnostics available
			OFF	PROFINET diagnostics not available
			Flashing	Flashes only together with the BF LED; watchdog triggered
RDY	Green/ yellow/ red	Ready	Green ON	Device is ready for operation.
			Flashing green/ yellow	Communications power undervoltage or surge voltage Overtemperature
			Flashing green, LED D yellow on	Device is in standby mode.
			Yellow ON	Firmware/bus coupler is booting
			Yellow flashing	Firmware update is being performed.
			Flashing yellow/ red	Firmware update has failed.
			Flashing red	Faulty firmware
			OFF	Device is not ready for operation.

Designation	Color	Meaning	State	Description
D	Red/ yellow/ green	Diagnostics of local bus communication		
		Run	Green ON	The station is ready for operation, communication within the station is OK. All data is valid. There are no faults.
		Active	Green flashing	The station is ready for operation, communication within the station is OK. The data is not valid. Valid data from the controller/higher-level network not available. There is no fault in the module.
		Ready	Yellow ON	The station is ready for operation, no data exchange taking place.
			Yellow flashing	Access from Startup+ in I/O check mode
			Flashing yellow/red	Local bus error during active I/O check
			Flashing red	Local bus error on startup
				Possible causes:
				Configuration cannot be generated, information is missing from a device
				Chip version of a device is <V1.1
				The desired and actual configuration are different
				No local bus device connected
				The maximum number of local bus devices is exceeded.
			Red ON	The station is ready for operation but has lost connection to at least one device.
	Possible causes:			
	Communication error			
	Local bus device has been removed or configured device is missing.			
		Reset at a local bus device		
		Serious device error at a local bus device (local bus device can no longer be reached)		
	Power down	OFF	Device in (power) reset.	
E	Yellow/ red	Error	Yellow ON	I/O warning at a local bus device
			Red ON	I/O error at a local bus device
			OFF	No I/O messages present.

9 Diagnostic indicators for PROFINET

States during operation

LED	Meaning
SF OFF/ BF OFF	PROFINET controller was able to establish communication without errors.

States in the event of an error

LED	Meaning	Measure/remedy in the event of an error
SF OFF/ BF flashing	PROFINET device is waiting for communication with the PROFINET controller.	No error
	The logic communication connection has been interrupted. The PROFINET controller can no longer be accessed.	Check the connection between the PROFINET controller and the PROFINET device. Make sure that the PROFINET device name of the PROFINET device is identical with the configuration.
	The PROFINET device is not assigned a PROFINET device name.	Assign the PROFINET device name using the relevant tool.
SF OFF/ BF ON	The physical communication path has been interrupted. The PROFINET controller can no longer be accessed.	Restore the physical connection between the PROFINET controller and the PROFINET device.
SF ON/ BF OFF	Diagnostic data is available.	Read the diagnostic message using the relevant tool.
SF flashing/ BF flashing	Hardware watchdog has been triggered.	Execute a reset. Replace the device when the error occurs again.

States during firmware update

LED	Meaning
RDY flashing	BootP requests are sent and the firmware container is loaded via tftp.
RDY ON / M ON	Firmware is saved.



The firmware update can take several minutes.

The bus coupler is restarted automatically after a successful update.

10 Diagnostic status register

Information on the operating and error states of the Axioline F local bus is stored in the diagnostic status register of the bus coupler. A state of the Axioline F local bus is assigned to each bit in the diagnostic status register.

The states in the error bits (F_PW_BIT, F_PF_BIT, F_BUS_BIT, F_CTRL_BIT) are described in greater detail using the two diagnostic parameter registers. For information on this, please refer to the AXL F SYS DIAG user manual.

Structure of the diagnostic status register

Bit	Designation	Meaning	
00	F_PW_BIT	I/O warning	At least one device indicates an I/O warning.
01	F_PF_BIT	Peripheral fault	At least one device indicates a peripheral fault.
02	F_BUS_BIT	Bus error	A bus error has occurred.
03	-	Reserved	
04	-	Reserved	
05	F_RUN_BIT	Run	Data cycles are being exchanged, the output data is enabled.
06	F_ACTIVE_BIT	Active	Configuration is active, PDI to the devices is possible, data exchange with invalid/non-enabled process data.
07	F_READY_BIT	Ready	The local bus master is ready for operation, no data exchange over the bus.
08	F_BD_BIT	Bus different	A device which does not belong to the current configuration has been detected at the last interface.
09	F_BASP_BIT	SYS_FAIL	The controller is in the STOP state or no application program has been loaded. The output data is blocked (substitute value behavior is active).
10	F_FORCE_BIT	Force Mode	Force mode (startup tool/I/O check is active).
11	F_SYNC_BIT	Synchronization	Synchronization between higher-level system and local bus master has failed.
12	F_PARA_BIT	Parameter error	Startup parameters missing for at least one device.
13 ... 15	-	Reserved	

The diagnostic status register can be read using asynchronous services (index 2210_{hex}, 8720_{hex}).

Example in PC Worx: sending a read service

The RDREC function block is available for sending read services.

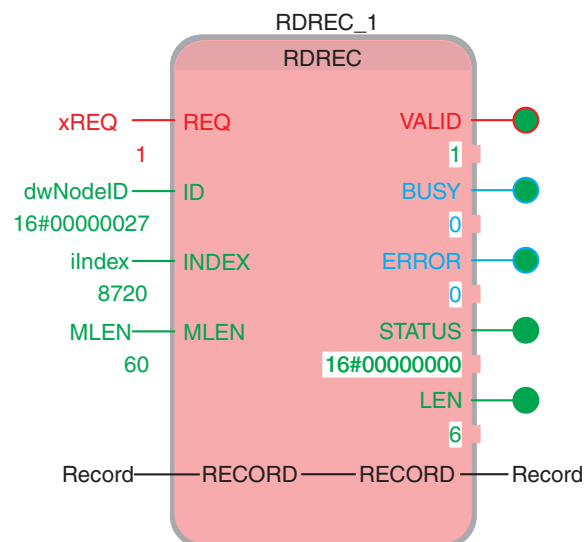

Figure 6 RDREC function block

- Open the bus configuration workspace.
- In the “Bus Structure” window, select the bus coupler.
- In the “Device Details” window, select the “Module Settings” tab.
- Read the node ID (**decimal**) of the bus coupler and enter it in **hexadecimal form** at the ID input of the function block.



Please note:
The node ID is generated automatically by PC Worx and may therefore vary in different projects.

The read service is sent on a rising edge at the REQ input of the function block. If the VALID output is TRUE, the response to the service is stored in I/O variable RECORD.

The diagnostic status register is located in byte 0 and byte 1. In the example, the following response is stored in variable RECORD:

Record	
[1]	16#00
[2]	16#E0
[3]	16#00
[4]	16#00
[5]	16#00
[6]	16#00
[7]	16#00
[8]	16#00
[9 ... 15]	16#00

In this example, the diagnostic status register has the value 00E0_{hex} (0000 0000 1110 0000_{bin}). Bits 5, 6, and 7 are TRUE. This means that data cycles are being exchanged, the configuration is active, and the local bus master is ready.

11 Diagnostic alarms

PROFINET enables the PROFINET device to store diagnostic information together with the error location and error type.

In the default upon delivery the alarms are enabled, however, they can be disabled with parameters on startup.

An incoming alarm informs the PROFINET controller that diagnostic information has been stored.

When the diagnostic information has been removed, an outgoing alarm is transmitted to the controller.

If at least one piece of diagnostic information is stored, the SF LED is on. If no diagnostic information is present, the SF LED is off.

12 Startup

Default upon delivery/default settings

By default upon delivery, the following functions and features are available:

PROFINET name:	No name assigned
IP parameters:	0.0.0.0
Module designation:	AXL F BK PN
Vendor ID:	00B0 _{hex}
Device ID:	1000 _{hex}

Firmware started

Once you have supplied the bus coupler with power or pressed the reset button, the firmware is started. After completion of the firmware boot process the BF LED is either on or flashing.

Reset button

The reset button is located beneath the top marking label on the bus coupler.

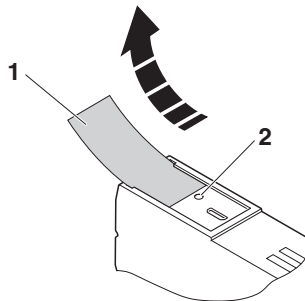

Figure 7 Reset button

- 1 Labeling field
- 2 Reset button

The reset button has two functions:

- Restarting the bus coupler
- Resetting of the default settings

Holding down the button during the initialization phase restores the default settings.

If you wish to restore the default settings, proceed as follows:

- Disconnect the power to the module.
- Press and hold the reset button.
- Switch on the power.

The LEDs indicate the initialization phase:

LED	State	Meaning
RDY	OFF	Starting firmware
RDY	Yellow ON	Initializing firmware
RDY	Green	Initialization complete

- When the RDY LED lights up green, release the button. The default settings are restored.

Documentation



How to assign the PROFINET names and the IP address as well as how to startup a device within a PROFINET system is described in the following documents:

- "PC WORX" quick start guide
- "Configuring INTERBUS devices in a PROFINET network using the example of STEP 7" quick start guide

For the order designations, please refer to the ordering data.

The documentation can be found on the Internet at phoenixcontact.net/products.

13 Service interface

The service interface is located beneath the top marking field on the bus coupler.

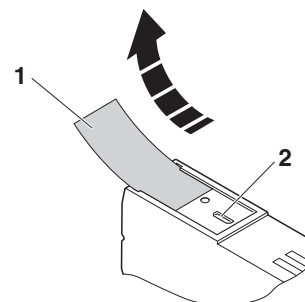

Figure 8 Service interface

- 1 Labeling field
- 2 Service interface

You can connect the bus coupler to a PC on which the Startup+ startup/diagnostic tool is running via USB using the service interface.

Startup+ offers the following functions:

- Parameterization of the station I/O modules
- I/O check
- Diagnostics



For detailed information on Startup+, please refer to the UM QS EN STARTUP+ user manual.

14 Parameterization

PC Worx

Parameterization of the PROFINET device in PC Worx requires at least PC Worx Version 6.30. This is part of the AUTOMATIONWORX Software Suite 1.80 and 1.81.

An online data sheet of the device with important technical data and a configuration file are integrated into PC Worx. If several versions of the configuration file are available, make sure that you are working with the file version that corresponds to the firmware/hardware version used.

Other tools

The PROFINET device is parameterized using the configuration tool of the PROFINET controller. Please integrate the corresponding GSDML file of the bus coupler into the relevant software tool (STEP 7/HW Config, ...).



Make sure you always use the latest version of the FDCML/GSDML file and the latest documentation for the bus coupler. The latest files and documentation can be found on the Internet at phoenixcontact.net/products.

15 Device replacement

Devices can be replaced without having to reconfigure them within the PROFINET network. The station name and address are assigned by the control system to the newly added PROFINET bus coupler using the neighborhood detection function.

16 Phoenix Redundancy Layer (PRL)

The Phoenix Redundancy Layer (PRL) makes it possible to design a redundant system with two PROFINET controllers. One controller is configured as the primary I/O controller and the other as the backup I/O controller. Depending on which PROFINET controller provides valid values, the bus coupler operated at field level adopts these values or uses failsafe values.



PRL (or shared device) and MRP can be used simultaneously if the PROFINET update time is ≥ 8 ms and the PROFINET watchdog time is > 200 ms.

17 Dynamic configuration on the local bus

You can use the "Dynamic configuration" function with this bus coupler.

Dynamic configuration is the specification and configuration of a maximum configuration. Any subgroup of this maximum configuration can be operated.

18 Substitute value behavior

If Ethernet communication fails or an error occurs in the local bus, all outputs of the station are set to the substitute values previously parameterized on the module.

In order to do this, plug and play mode must be deactivated and the process data watchdog must be activated.



For the possible substitute values of a module, please refer to the relevant module-specific data sheet.

19 Simple Network Management Protocol - SNMP

The bus coupler supports SNMP v1 and v2c.

Management Information Base - MIB



The corresponding latest MIBs are available on the Internet at phoenixcontact.net/products.

For the object descriptions, please refer to the ASN1 descriptions for this product.

The password for read access is "public" and cannot be changed.

By default upon delivery, the password for write/read access is "private" and can be modified at any time.

20 WBM - Web-based management

The device has a web server, which generates the required pages for web-based management and, depending on the requirements of the user, sends them to a standard web browser. Web-based management can be used to access static information (e.g., technical data, MAC address) or dynamic information (e.g., IP address, status information).

Calling web-based management

The device web server can be addressed using the IP address if configured accordingly. The homepage (web page) of the device is accessed by entering the URL "http://ip-address".

Example: http://172.16.113.38



If you cannot access the WBM pages, check the connection settings in your browser and deactivate the proxy, if set.

21 Firmware update

In order to update the firmware of the bus coupler, provide the bus coupler with a firmware container via a TFTP server or load it onto the bus coupler via FTP. Any FTP client or TFTP server can be used for this, e.g., the Factory Manager. If the Factory Manager is not used, initialize the firmware update via web-based management. When carrying out the firmware update, the RDY LED flashes yellow.



For detailed information on firmware update via TFTP, please refer to application note TFTP FIRMWARE UPDATE AXL F BK.

Данный компонент на территории Российской Федерации

Вы можете приобрести в компании MosChip.

Для оперативного оформления запроса Вам необходимо перейти по данной ссылке:

<http://moschip.ru/get-element>

Вы можете разместить у нас заказ для любого Вашего проекта, будь то серийное производство или разработка единичного прибора.

В нашем ассортименте представлены ведущие мировые производители активных и пассивных электронных компонентов.

Нашей специализацией является поставка электронной компонентной базы двойного назначения, продукции таких производителей как XILINX, Intel (ex.ALTERA), Vicor, Microchip, Texas Instruments, Analog Devices, Mini-Circuits, Amphenol, Glenair.

Сотрудничество с глобальными дистрибьюторами электронных компонентов, предоставляет возможность заказывать и получать с международных складов практически любой перечень компонентов в оптимальные для Вас сроки.

На всех этапах разработки и производства наши партнеры могут получить квалифицированную поддержку опытных инженеров.

Система менеджмента качества компании отвечает требованиям в соответствии с ГОСТ Р ИСО 9001, ГОСТ РВ 0015-002 и ЭС РД 009

Офис по работе с юридическими лицами:

105318, г.Москва, ул.Щербаковская д.3, офис 1107, 1118, ДЦ «Щербаковский»

Телефон: +7 495 668-12-70 (многоканальный)

Факс: +7 495 668-12-70 (доб.304)

E-mail: info@moschip.ru

Skype отдела продаж:

moschip.ru

moschip.ru_4

moschip.ru_6

moschip.ru_9