

11 mm Square GS Encoders

Type: **EVER/EVEU/EVEV/EVEY**

■ Features

- Low Profile : Reflow Type 3.5 mm,
Wave Soldering Type 4 mm
- Minimized shaft wobble type is also available
- The reflow type allows the product to be automatically mounted and reflow-soldered



■ Recommended Applications

- Car audio, car navigation, car air conditioners

■ Explanation of Part Numbers

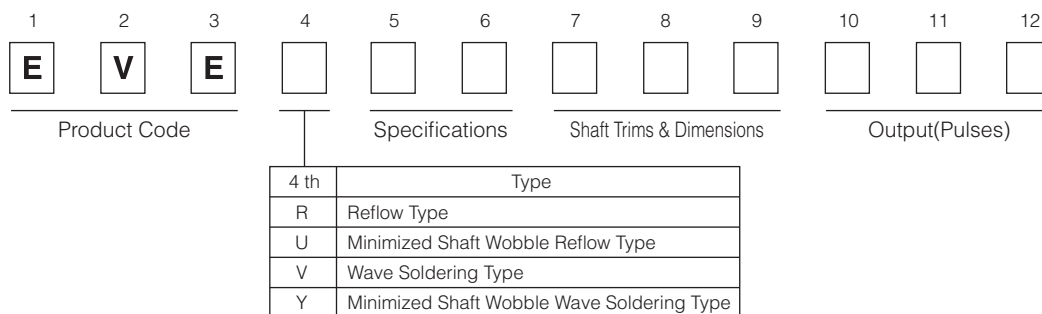

■ Specifications

		EVER (Reflow Type)	EVEV (Wave Soldering Type)	EVEU (Minimized Shaft Wobble Reflow Type)	EVEY (Minimized Shaft Wobble Wave Soldering Type)
Mechanical	Rotation Angle	360 ° (Endless)			
	Shaft Pull/Push Strength	100 N min.			
	Shaft Wobble	0.6×L/30 (mm) max.		0.35×L/30 (mm) max.	
	Rotation Torque	8 mN·m, 10 mN·m, 12 mN·m, 14 mN·m			
	Detents	16 points, 24 points, 30 points, 32 points			
	Shaft Length Range	L1=15 to 20 mm	L1=15 to 30 mm	L1=16 to 20 mm	
Electrical	Output Signals	Phase A and B			
	Resolution	8, 12, 15, 16 pulses/360 °			
	Rating	1 mA 10 V DC (at each bit)			
	Contact Resistance	1 Ω max.			
	Chattering	3 ms max.			
	Insulation Resistance	50 MΩ min. (at 250 V DC)			
	Dielectric Withstanding Voltage	300 V AC for 1 minute			
Switch Part	Bouncing	5 ms max.			
	Type	SPST Push-on			
	Rating	20 mA 16 V DC			
	Contact Resistance	100 mΩ max.			
	Operating Force	0.4 mm travel type : 3 N, 4 N , 6 N 1.5 mm travel type : 2.5 N, 4 N , 5 N			
Endurance	Travel	0.4 mm, 1.5 mm			
	Rotation Life (Encoder)	30,000 cycles min.			
	Operating Life (Switch)	30,000 cycles min.			
Minimum Quantity/Packing Unit		50 pcs. (Tray Pack)	100 pcs. (Tray Pack)	50 pcs. (Tray Pack)	100 pcs. (Tray Pack)
Quantity/Carton		250 pcs. or 300 pcs.	500 pcs.	250 pcs. or 300 pcs.	500 pcs.

Design and specifications are each subject to change without notice. Ask factory for the current technical specifications before purchase and/or use.
Should a safety concern arise regarding this product, please be sure to contact us immediately.

■ Dimensions in mm (not to scale)

No. 1

EVER
(Reflow Type)

General dimension tolerance : ± 0.5
() dimensions are reference dimensions.

Bushing length		L ¹	(L ²)
B	5.0 mm	15.0 mm to 17.0 mm	11.5 mm to 13.5 mm
	7.0 mm	17.0 mm to 20.0 mm	13.5 mm to 16.5 mm

Shaft shape and dimension

No. 2

EVEU
(Minimized Shaft Wobble Reflow Type)

General dimension tolerance : ± 0.5
() dimensions are reference dimensions.

L ¹	(L ²)	(L ³)
16.0 mm to 20.0 mm	12.5 mm to 16.5 mm	6.5 mm to 10.5 mm

Material: Zinc alloy for die casting
Shaft shape and dimension

No. 3

EVEV
(Wave Soldering Type)

General dimension tolerance : ± 0.5
() dimensions are reference dimensions.

Bushing length		L ¹	(L ²)
B	5.0 mm	15.0 mm to 17.0 mm	11.0 mm to 13.0 mm
	7.0 mm	17.0 mm to 30.0 mm	13.0 mm to 26.0 mm

Shaft shape and dimension

Design and specifications are each subject to change without notice. Ask factory for the current technical specifications before purchase and/or use.
Should a safety concern arise regarding this product, please be sure to contact us immediately.

■ Dimensions in mm (not to scale)

No. 4

EVEY
(Minimized Shaft Wobble
Wave Soldering Type)

General dimension tolerance : ± 0.5
() dimensions are reference dimensions.

Material: Zinc alloy for die casting

L ¹	(L ²)	(L ³)
16.0 mm to 20.0 mm	12.0 mm to 16.0 mm	6.0 mm to 10.0 mm

■ PWB mounting hole for reference

(Reflow Type)

* The position changes with Resolution pulse
(Tolerance : ±0.1)
View from mounting side

(Wave Soldering Type)

(Pitch tolerance : ±0.1)
View from mounting side
PWB thickness t=1.6

■ Encoder / Switch Circuit

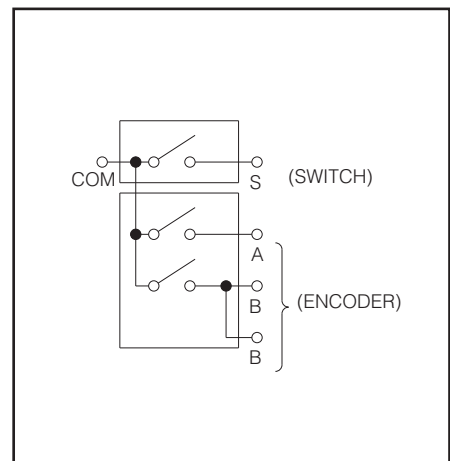

■ Phase Difference



■ Test Circuit Diagram

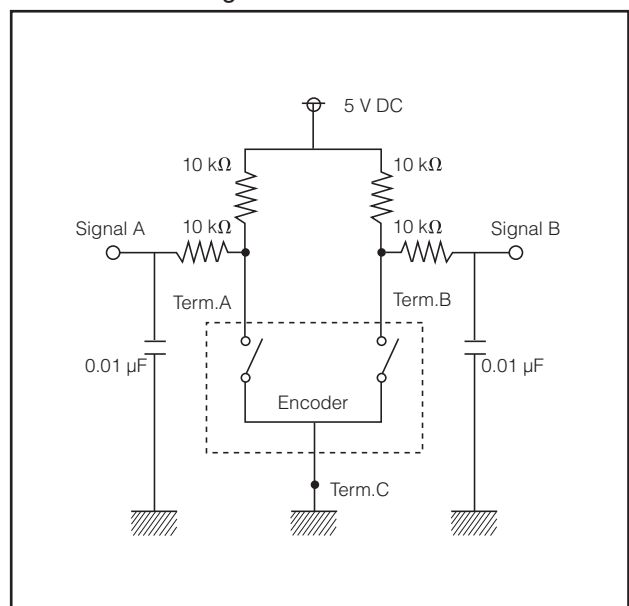

Design and specifications are each subject to change without notice. Ask factory for the current technical specifications before purchase and/or use.
Should a safety concern arise regarding this product, please be sure to contact us immediately.

Mouser Electronics

Authorized Distributor

Click to View Pricing, Inventory, Delivery & Lifecycle Information:

Panasonic:

[EVE-VCGJL016B](#) [EVE-Y75VL215B](#) [EVE-Y74VL215B](#) [EVE-UPCAH516B](#) [EVE-YBCAJ016B](#) [EVE-YPCAJ016B](#)
[EVE-UBCAH516B](#) [EVE-UPCAH508B](#) [EVE-UBCAH508B](#) [EVE-YBCAJ008B](#) [EVE-YPCAJ008B](#) [EVE-YPCAJ008B](#)
[EVE-YPCAJ016B](#) [EVE-VGHFL816B](#) [EVE-YBCAJ008B](#) [EVE-RLCJL008B](#) [EVE-YBCAJ016B](#) [EVE-YFCCL516B](#) [EVE-](#)
[RQHPK016B](#) [EVE-U22AH512B](#)

Данный компонент на территории Российской Федерации

Вы можете приобрести в компании MosChip.

Для оперативного оформления запроса Вам необходимо перейти по данной ссылке:

<http://moschip.ru/get-element>

Вы можете разместить у нас заказ для любого Вашего проекта, будь то серийное производство или разработка единичного прибора.

В нашем ассортименте представлены ведущие мировые производители активных и пассивных электронных компонентов.

Нашей специализацией является поставка электронной компонентной базы двойного назначения, продукции таких производителей как XILINX, Intel (ex.ALTERA), Vicor, Microchip, Texas Instruments, Analog Devices, Mini-Circuits, Amphenol, Glenair.

Сотрудничество с глобальными дистрибьюторами электронных компонентов, предоставляет возможность заказывать и получать с международных складов практически любой перечень компонентов в оптимальные для Вас сроки.

На всех этапах разработки и производства наши партнеры могут получить квалифицированную поддержку опытных инженеров.

Система менеджмента качества компании отвечает требованиям в соответствии с ГОСТ Р ИСО 9001, ГОСТ РВ 0015-002 и ЭС РД 009

Офис по работе с юридическими лицами:

105318, г.Москва, ул.Щербаковская д.3, офис 1107, 1118, ДЦ «Щербаковский»

Телефон: +7 495 668-12-70 (многоканальный)

Факс: +7 495 668-12-70 (доб.304)

E-mail: info@moschip.ru

Skype отдела продаж:

moschip.ru

moschip.ru_4

moschip.ru_6

moschip.ru_9