

Dual line programmable transient voltage suppressor for SLIC protection

Datasheet - production data

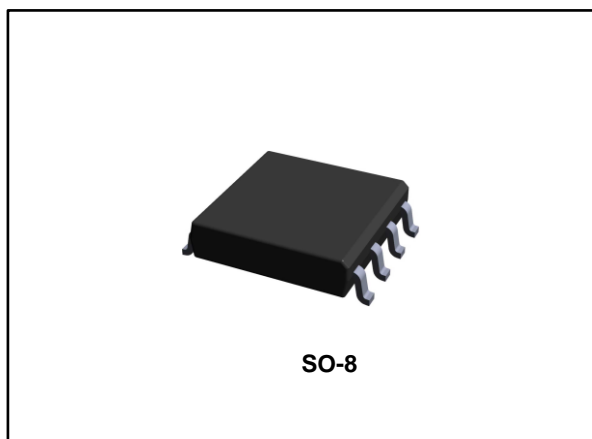

Features

- Dual line programmable transient voltage suppressor with separated gates
- Wide negative firing voltage range: $V_{Gn} = -175\text{ V max.}$
- Low dynamic switching voltages: V_{FP} and V_{DGL}
- Low gate triggering current: $I_{GT} = 5\text{ mA max}$
- Peak pulse current: $I_{PP} = 40\text{ A (5/310 }\mu\text{s)}$
- Holding current: $I_H = 150\text{ mA min.}$

Benefits

- A Trisil™ is not subject to ageing and provides a fail safe mode in short circuit for a better protection.
- Trisils are used to help equipment to meet various standards such as UL1950, IEC 60950 / CSA C22.2, UL1459 and TIA-968-A (formerly FCC part 68).
- Trisils have UL94 V0 resin approved (Trisils are UL497B approved - file: E136224).

Description

This device has been especially designed to protect 2 new high voltage, as well as classical SLICs, against transient overvoltages.

Positive overvoltages are clamped by 2 diodes. Negative surges are suppressed by 2 thyristors, their breakdown voltage being referenced to $-V_{BAT}$ through the gate. Separated gates allow the SLICs to be supplied by two different voltages.

Figure 1: Functional diagram

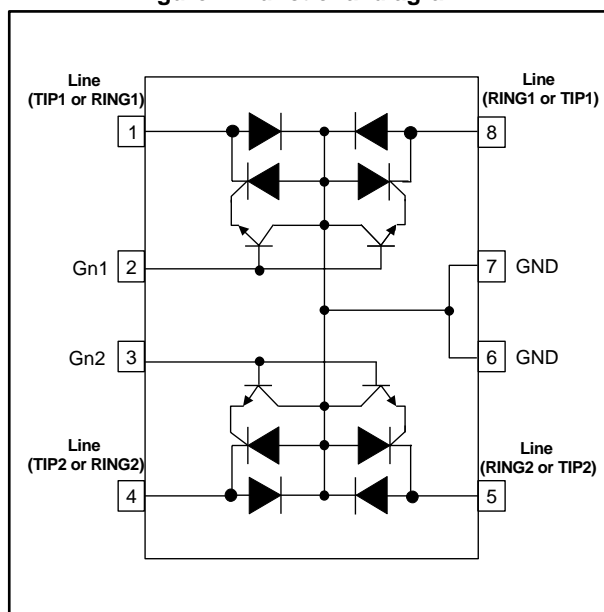

1 Characteristics

Table 1: Standards compliance

Standard	Peak surge voltage (V)	Voltage waveform	Required peak current (A)	Current waveform	Minimum serial resistor to meet standard (Ω)
GR-1089 Core First level	2500	2/10 μ s	500	2/10 μ s	20
	1000	10/1000 μ s	100	10/1000 μ s	30
GR-1089 Core Second level	5000	2/10 μ s	500	2/10 μ s	40
GR-1089 Core Intra-building	1500	2/10 μ s	100	2/10 μ s	0
ITU-T-K20/K21	6000	10/700 μ s	150	5/310 μ s	110
	1500		37.5		0
ITU-T-K20 (IEC 61000-4-2)	8000	1/60 ns	ESD contact discharge		0
	15000		ESD air discharge		0
IEC 61000-4-5	4000	10/700 μ s	100	5/310 μ s	60
	4000	1.2/50 μ s	100	8/20 μ s	5
TIA-968-A, lightning surge type A	1500	10/160 μ s	100	10/160 μ s	26
	800	10/560 μ s	200	10/560 μ s	19
TIA-968-A, lightning surge type B	1000	9/720 μ s	25	5/320 μ s	0

Table 2: Thermal resistances

Symbol	Parameter	Value	Unit
$R_{th(j-a)}$	Junction to ambient	170	$^{\circ}\text{C/W}$

Table 3: Absolute ratings ((0 °C < T_j < 70 °C, unless otherwise specified))

Symbol	Parameter	Value	Unit	
I _{pp}	Telcordia GR-1089-CORE Issue 6, May 2011, section 4	10/1000 μs	25	A
	TIA-968-A, lightning surge type A	10/560 μs	30	
	ITU-T K20/21/44/45, (10/700 μs open circuit voltage waveshape)	5/310 μs	40	
	TIA-968-A, lightning surge type A	10/160 μs	45	
	IEC 61000-4-5, (1.2/50 μs open circuit waveshape) with 10 Ω	2/40 μs	85	
	ITU-T K20/21/44/45, (1.2/50 μs open circuit voltage waveshape)	8/20 μs	90	
	Telcordia GR-1089-CORE Issue 6, (2/10 μs open circuit waveshape)	2/10 μs	100	
I _{TSM}	Non repetitive surge peak on-state current (50 Hz sinusoidal) ⁽¹⁾	t = 0.2 s t = 1 s t = 2 s t = 15 mn	5 3.5 3 1.3	A
V _{GN}	Negative battery voltage range	-40 °C < T _{amb} < +85 °C	-175	V
T _{stg}	Storage junction temperature range		-55 to + 150	°C
T _j	Maximum operating junction temperature			
T _L	Maximum temperature for soldering during 10 s			

Notes:

⁽¹⁾The rated current values may be applied either to the Ring to GND or to the Tip to GND terminal pairs. Additionally, the four terminal pairs may have their rated current values applied simultaneously (in this case the GND terminal current will be four times the rated current value of an individual terminal pair)

Figure 2: Electrical characteristics (definitions)

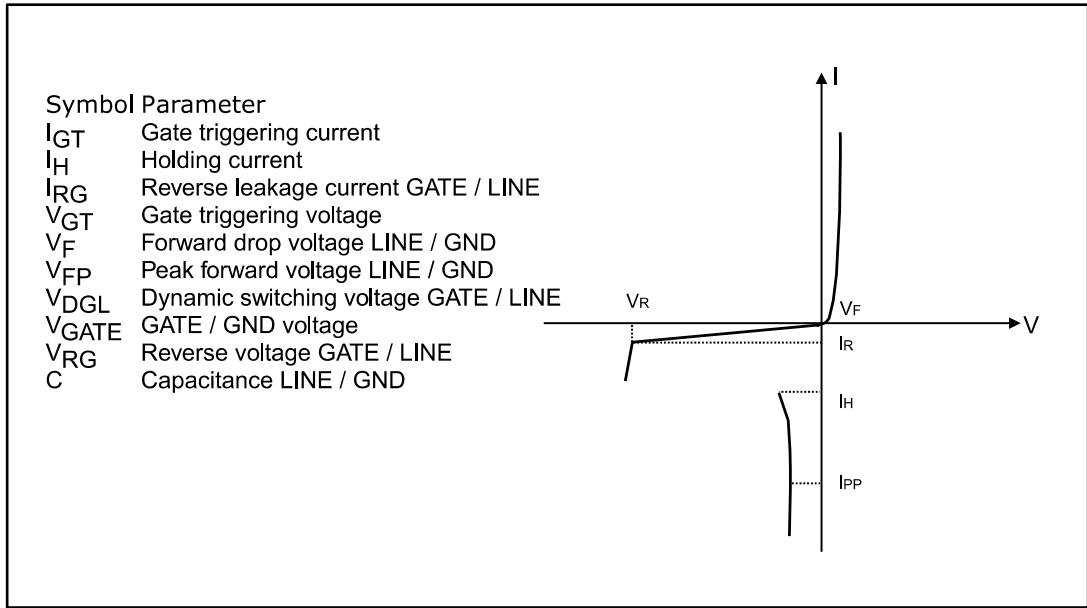

Figure 3: Pulse waveform

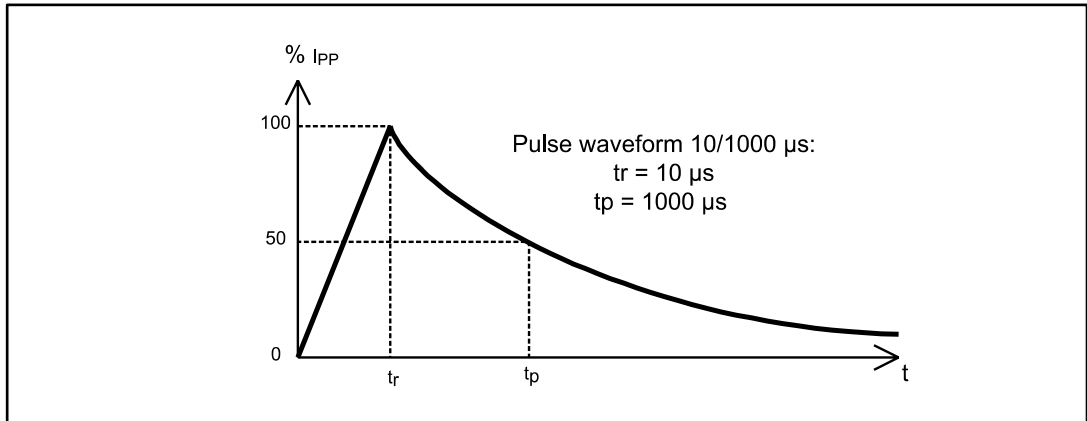

Table 4: Parameters ($T_j = 25\text{ °C}$ unless otherwise specified)

Symbol	Test conditions	Min.	Typ.	Max.	Unit
I_{GT}	$V_{LINE} = -48\text{ V}$	0.05		5	mA
I_H	$V_{Gn} = -48\text{ V}$	150			mA
V_{GT}	at I_{GT}			2.5	V
I_{RG}	$V_{RG} = -175\text{ V}$			5	μA
	$V_{RG} = -175\text{ V}$			50	
$V_{DGL}^{(1)}$	$V_{Gn} = -48\text{ V}$, $10/700\text{ }\mu\text{s}$, 1.5 kV , $R_S = 0\text{ }\Omega$, $I_{PP} = 37.5\text{ A}$			5	V
V_F	$I_F = 1\text{ A}$			2	V
V_{FP}	$10/700\text{ }\mu\text{s}$, 1.5 kV , $R_S = 0\text{ }\Omega$, $I_{PP} = 37.5\text{ A}$			8	V
I_R	$V_{Gn/LINE} = -1\text{ V}$, $V_{LINE} = -175\text{ V}$			5	μA
	$V_{Gn/LINE} = -1\text{ V}$, $V_{LINE} = -175\text{ V}$			50	
C	$V_{LINE} = -50\text{ V}$, $V_{RMS} = 1\text{ V}$, $f = 1\text{ MHz}$		18		pF
	$V_{LINE} = -2\text{ V}$, $V_{RMS} = 1\text{ V}$, $f = 1\text{ MHz}$		35		

Notes:

⁽¹⁾The oscillations with a time duration lower than 50 ns are not taken into account.

Table 5: Recommended gate capacitance

Symbol	Component	Min.	Typ.	Max.	Unit
C_G	Gate decoupling capacitance	100	220	-	nF

2 Technical information

The LCDP1521S is particularly optimized for the new telecom applications such as the fiber in the loop, the WLL, the remote central office. In this case, the operating voltages are smaller than in the classical system. This makes the high voltage SLICs particularly suitable. The schematics of [Figure 4: "Protection of high voltage SLICs"](#) shows the topologies most frequently used for these applications.

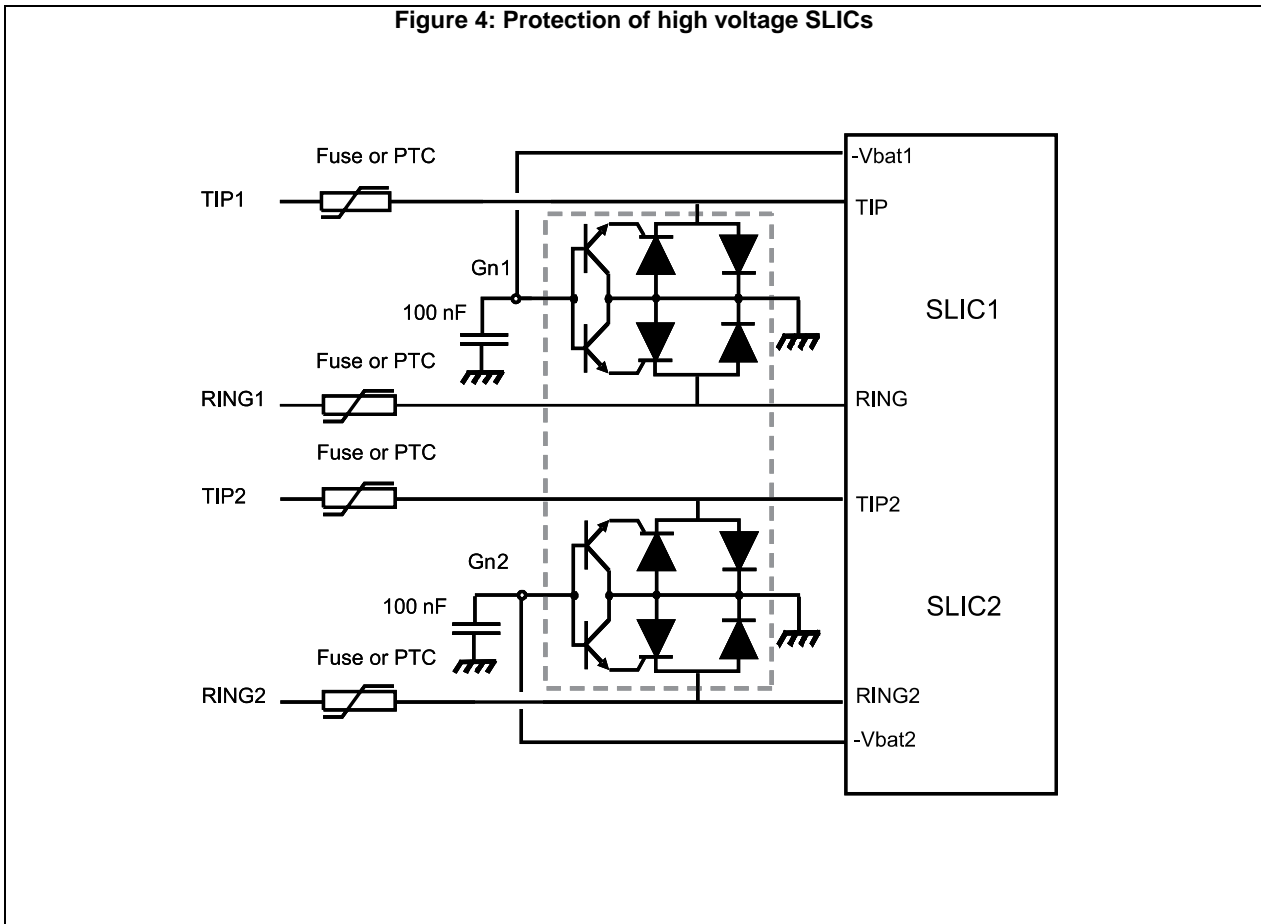

Figure 5: Surge peak current versus duration

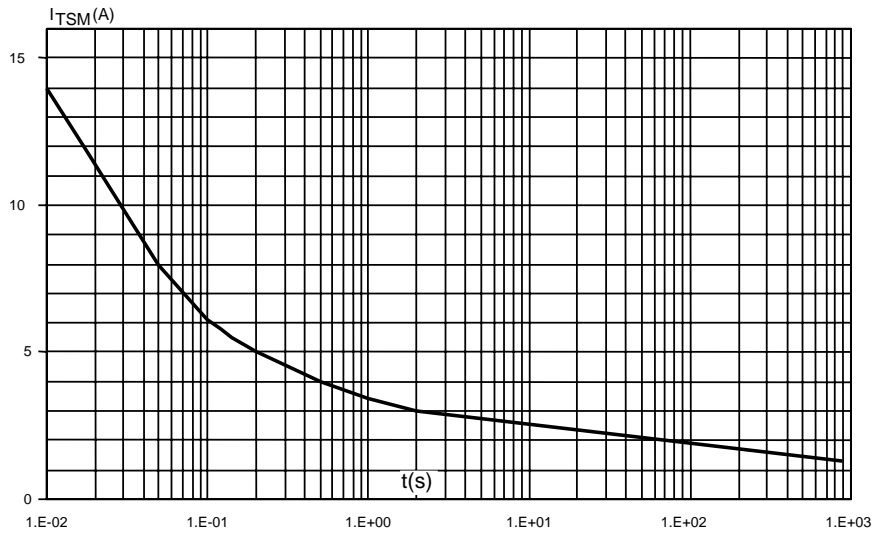
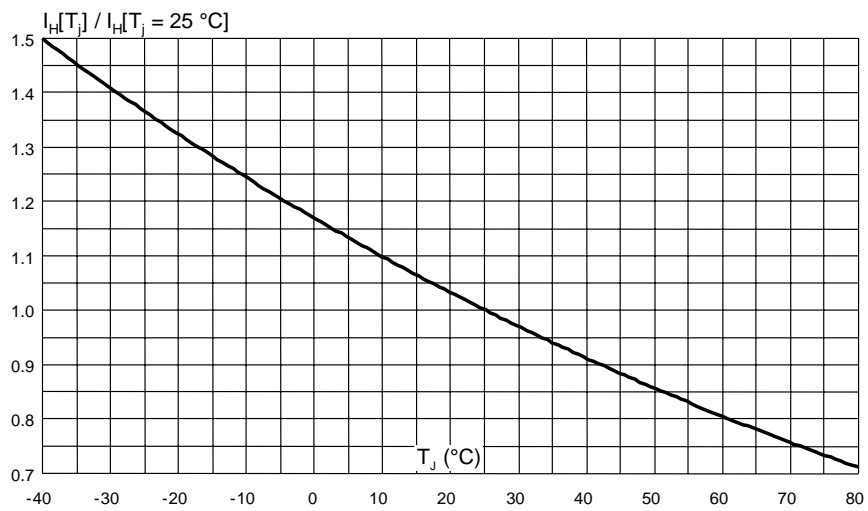

Figure 6: Relative variation of holding current versus junction temperature



3 Package information

In order to meet environmental requirements, ST offers these devices in different grades of ECOPACK® packages, depending on their level of environmental compliance. ECOPACK® specifications, grade definitions and product status are available at: www.st.com. ECOPACK® is an ST trademark.

3.1 SO-8 package information

Figure 7: SO-8 package outline

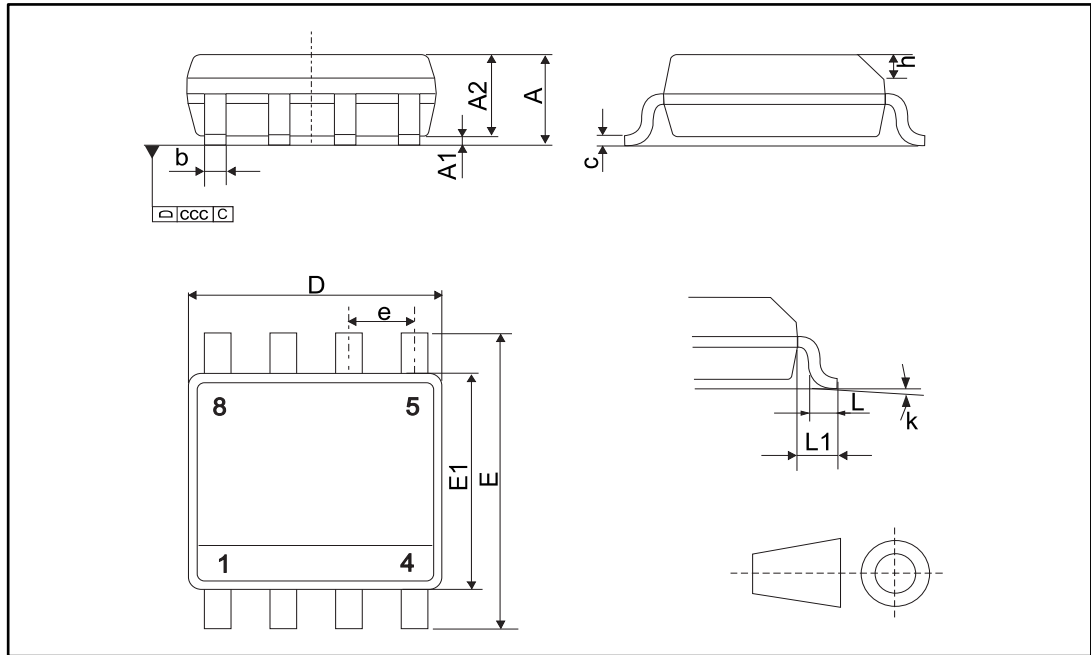

Table 6: SO-8 package mechanical data

Ref.	Dimensions					
	Millimeters			Inches		
	Min.	Typ.	Max.	Min.	Typ.	Max.
A			1.75			0.069
A1	0.1		0.25	0.004		0.010
A2	1.25			0.049		
b	0.31		0.51	0.012		0.020
c	0.10		0.25	0.004		0.010
D	4.80	4.90	5.00	0.189	0.193	0.197
E	5.80	6.00	6.20	0.228	0.236	0.244
E1	3.80	3.90	4.00	0.150	0.154	0.157
e		1.27			0.050	
h	0.25		0.50	0.010		0.020
L	0.40		1.27	0.016		0.05
L1		1.04			0.041	
k°	0		8	0		8
ccc			0.10			0.004

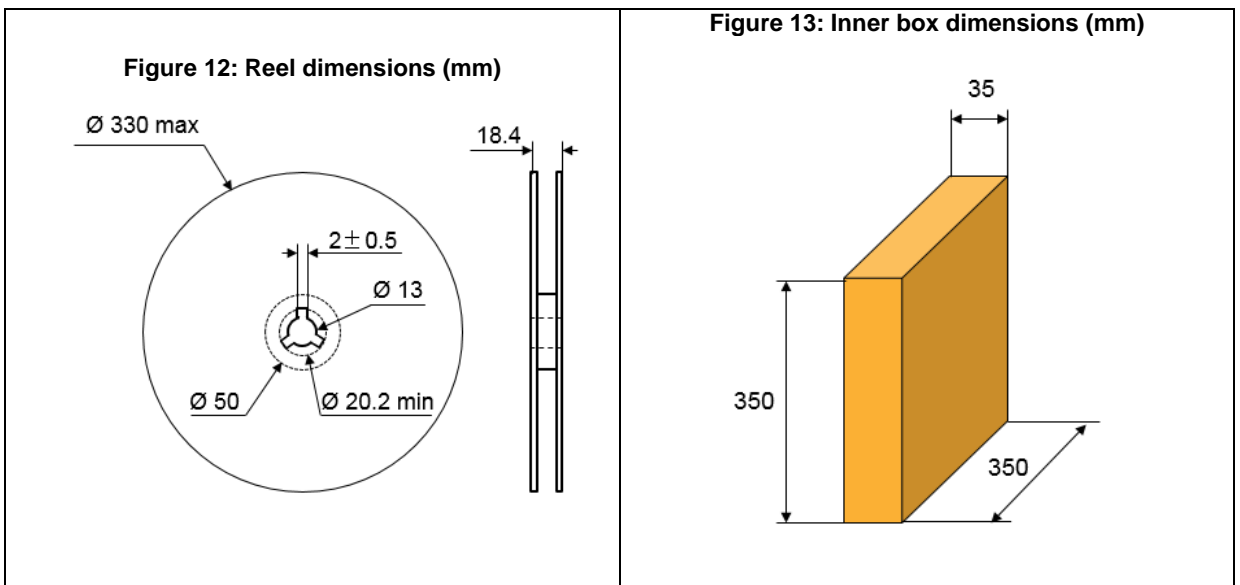
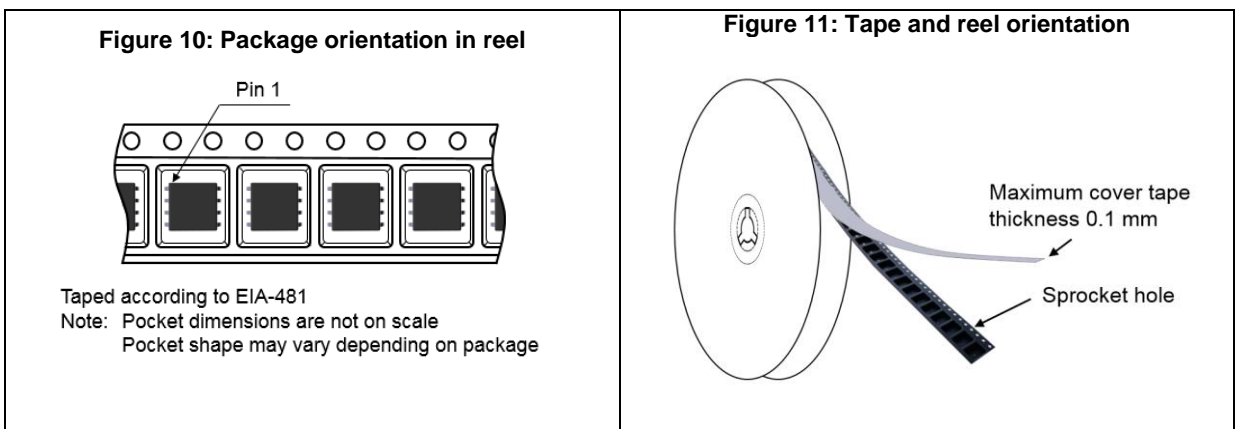
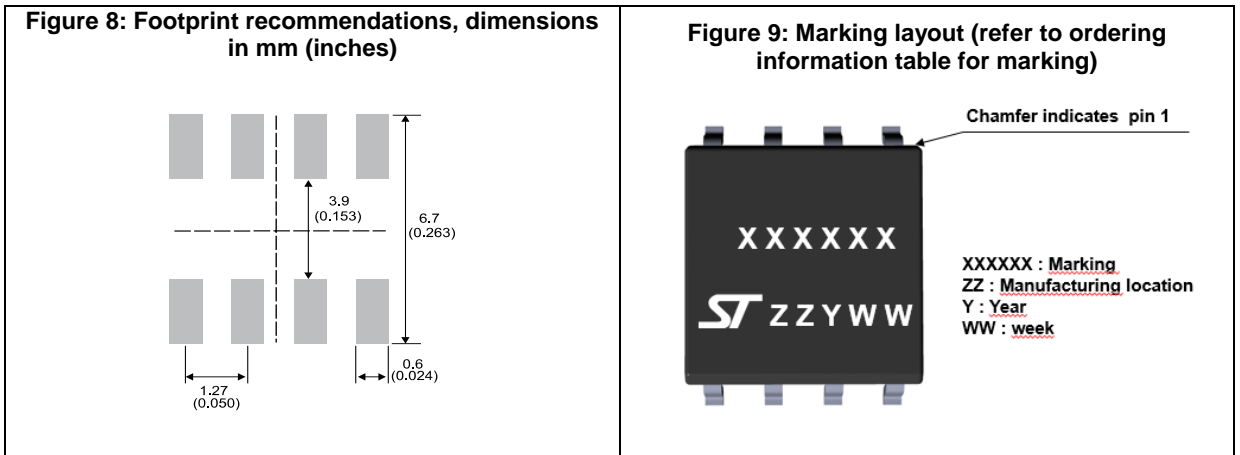

Figure 14: Tape and reel outline

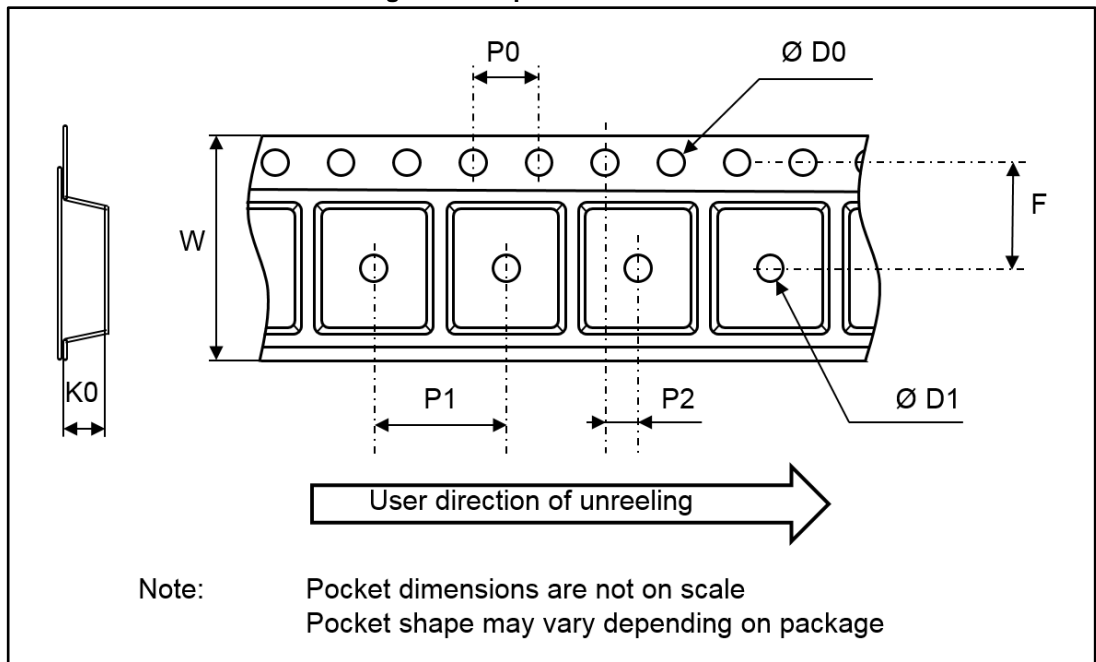
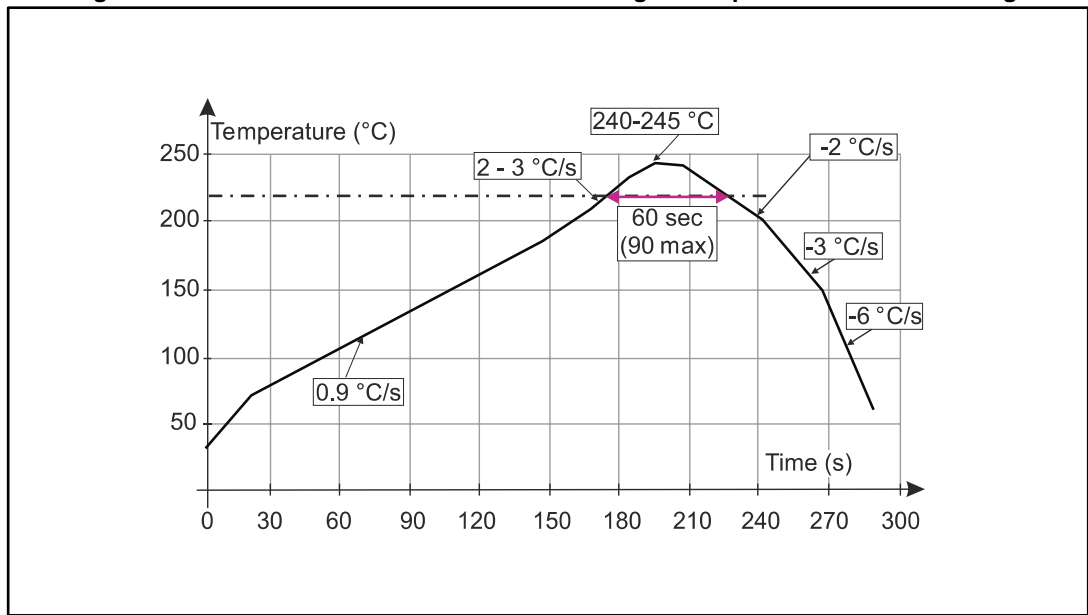

Table 7: Tape and reel mechanical data

Ref.	Dimensions		
	Millimeters		
	Min.	Typ.	Max.
P0	3.9	4	4.1
P1	7.9	8	8.1
P2	1.95	2	2.05
ØD0	1.45	1.5	1.6
ØD1	1.6		
F	5.45	5.5	5.55
K0	2.5	2.6	2.7
W	11.7	12	12.3

Figure 15: ST ECOPACK® recommended soldering reflow profile for PCB mounting



Minimize air convection currents in the reflow oven to avoid component movement. Maximum soldering profile corresponds to the latest IPC/JEDEC J-STD-020.

4 Ordering information

Figure 16: Ordering information scheme

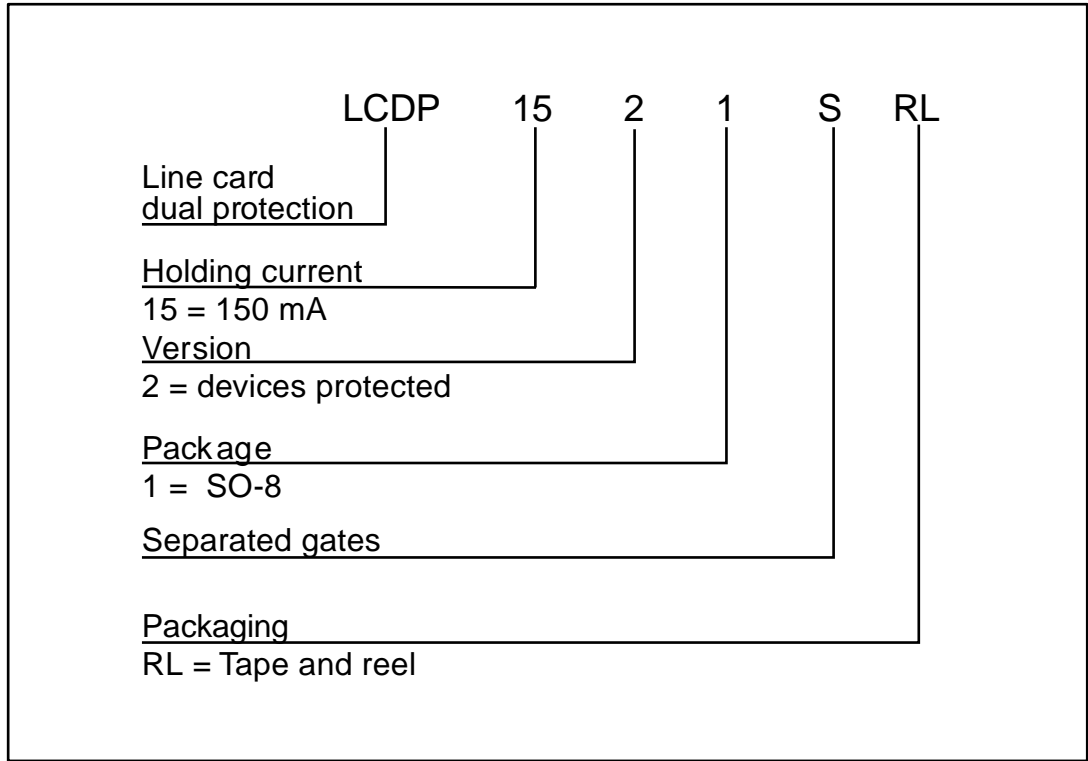

Table 8: Ordering information

Order code	Marking	Package	Weight	Base qty.	Delivery mode
LCDP1521SRL	DP152S	SO-8	0.08 g	2500	Tape and reel

5 Revision history

Table 9: Document revision history

Date	Revision	Changes
24-Sep-2009	1	First issue.
23-Feb-2012	2	Standardized nomenclature for Gn and Gp.
20-May-2015	3	Updated <i>Table 3</i> and package view.
02-Jul-2015	4	Updated package information.
08-Jul-2015	5	Updated <i>Figure 7</i> .
01-Oct-2016	6	Updated <i>Section 6: "Characteristics"</i> and <i>Section 8.1: "SO-8 package information"</i> . Minor format changes.
09-Feb-2017	7	Updated <i>Figure 7: "SO-8 package outline"</i> .

IMPORTANT NOTICE – PLEASE READ CAREFULLY

STMicroelectronics NV and its subsidiaries ("ST") reserve the right to make changes, corrections, enhancements, modifications, and improvements to ST products and/or to this document at any time without notice. Purchasers should obtain the latest relevant information on ST products before placing orders. ST products are sold pursuant to ST's terms and conditions of sale in place at the time of order acknowledgement.

Purchasers are solely responsible for the choice, selection, and use of ST products and ST assumes no liability for application assistance or the design of Purchasers' products.

No license, express or implied, to any intellectual property right is granted by ST herein.

Resale of ST products with provisions different from the information set forth herein shall void any warranty granted by ST for such product.

ST and the ST logo are trademarks of ST. All other product or service names are the property of their respective owners.

Information in this document supersedes and replaces information previously supplied in any prior versions of this document.

© 2017 STMicroelectronics – All rights reserved

Данный компонент на территории Российской Федерации

Вы можете приобрести в компании MosChip.

Для оперативного оформления запроса Вам необходимо перейти по данной ссылке:

<http://moschip.ru/get-element>

Вы можете разместить у нас заказ для любого Вашего проекта, будь то серийное производство или разработка единичного прибора.

В нашем ассортименте представлены ведущие мировые производители активных и пассивных электронных компонентов.

Нашей специализацией является поставка электронной компонентной базы двойного назначения, продукции таких производителей как XILINX, Intel (ex.ALTERA), Vicor, Microchip, Texas Instruments, Analog Devices, Mini-Circuits, Amphenol, Glenair.

Сотрудничество с глобальными дистрибьюторами электронных компонентов, предоставляет возможность заказывать и получать с международных складов практически любой перечень компонентов в оптимальные для Вас сроки.

На всех этапах разработки и производства наши партнеры могут получить квалифицированную поддержку опытных инженеров.

Система менеджмента качества компании отвечает требованиям в соответствии с ГОСТ Р ИСО 9001, ГОСТ РВ 0015-002 и ЭС РД 009

Офис по работе с юридическими лицами:

105318, г.Москва, ул.Щербаковская д.3, офис 1107, 1118, ДЦ «Щербаковский»

Телефон: +7 495 668-12-70 (многоканальный)

Факс: +7 495 668-12-70 (доб.304)

E-mail: info@moschip.ru

Skype отдела продаж:

moschip.ru

moschip.ru_4

moschip.ru_6

moschip.ru_9