

PRODUCT NO.  
SEE TABLE

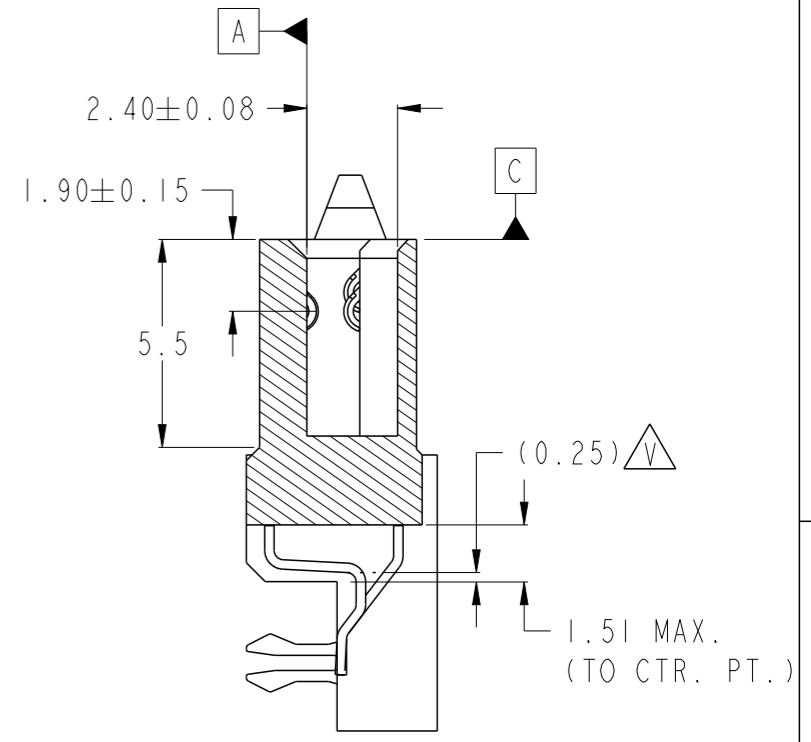

SECTION Y-Y  
SCALE 5:1

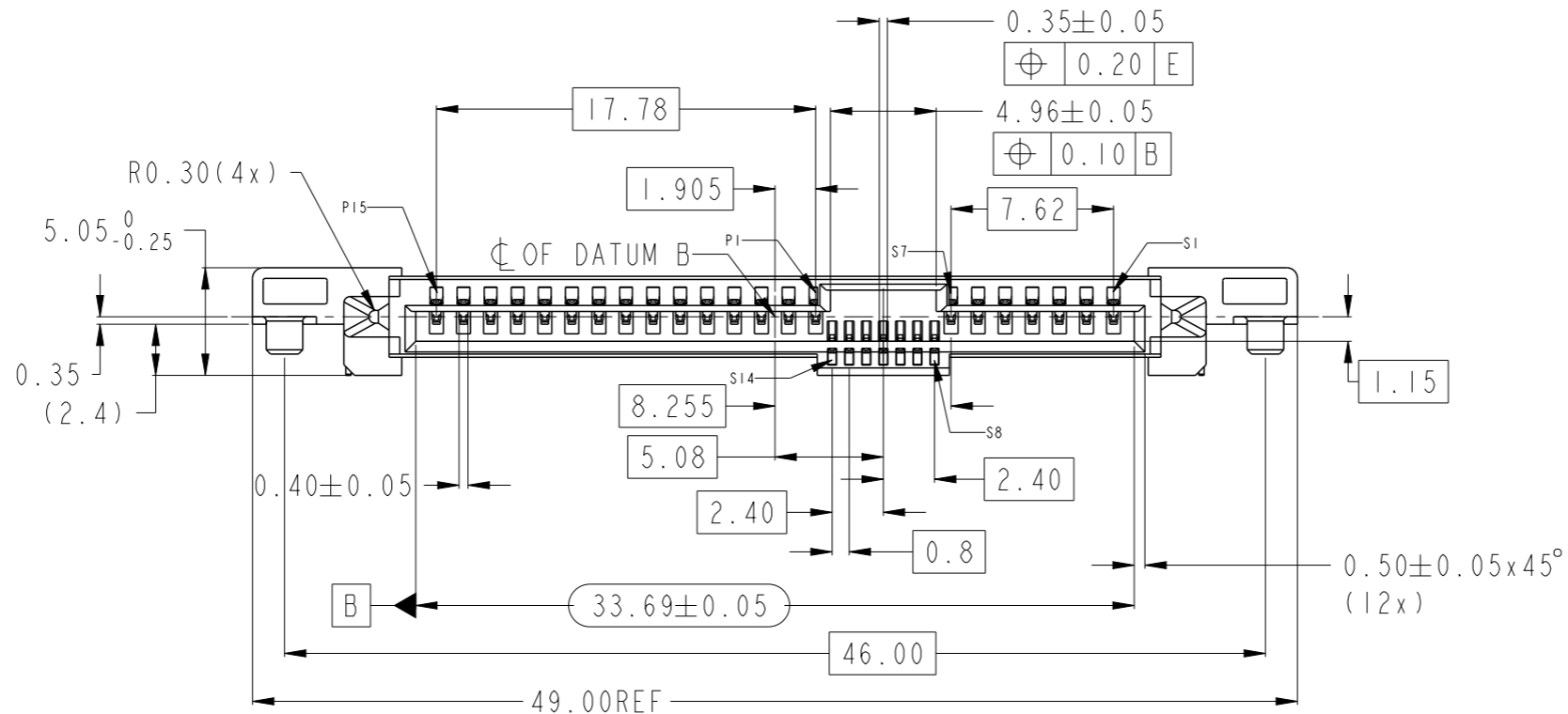
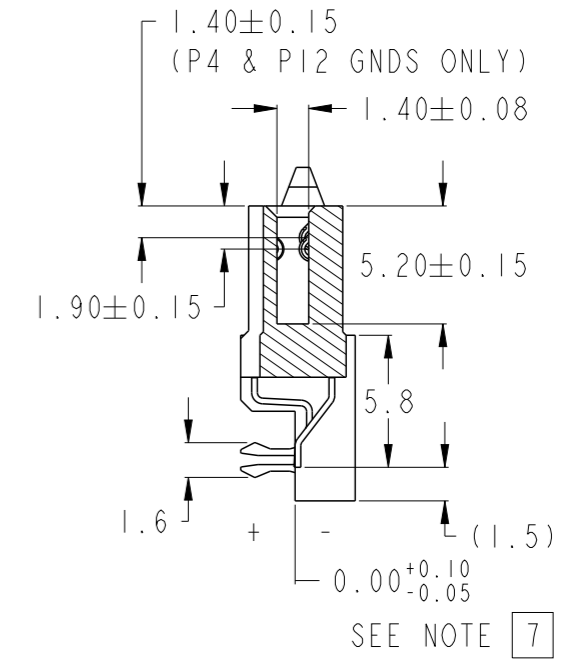
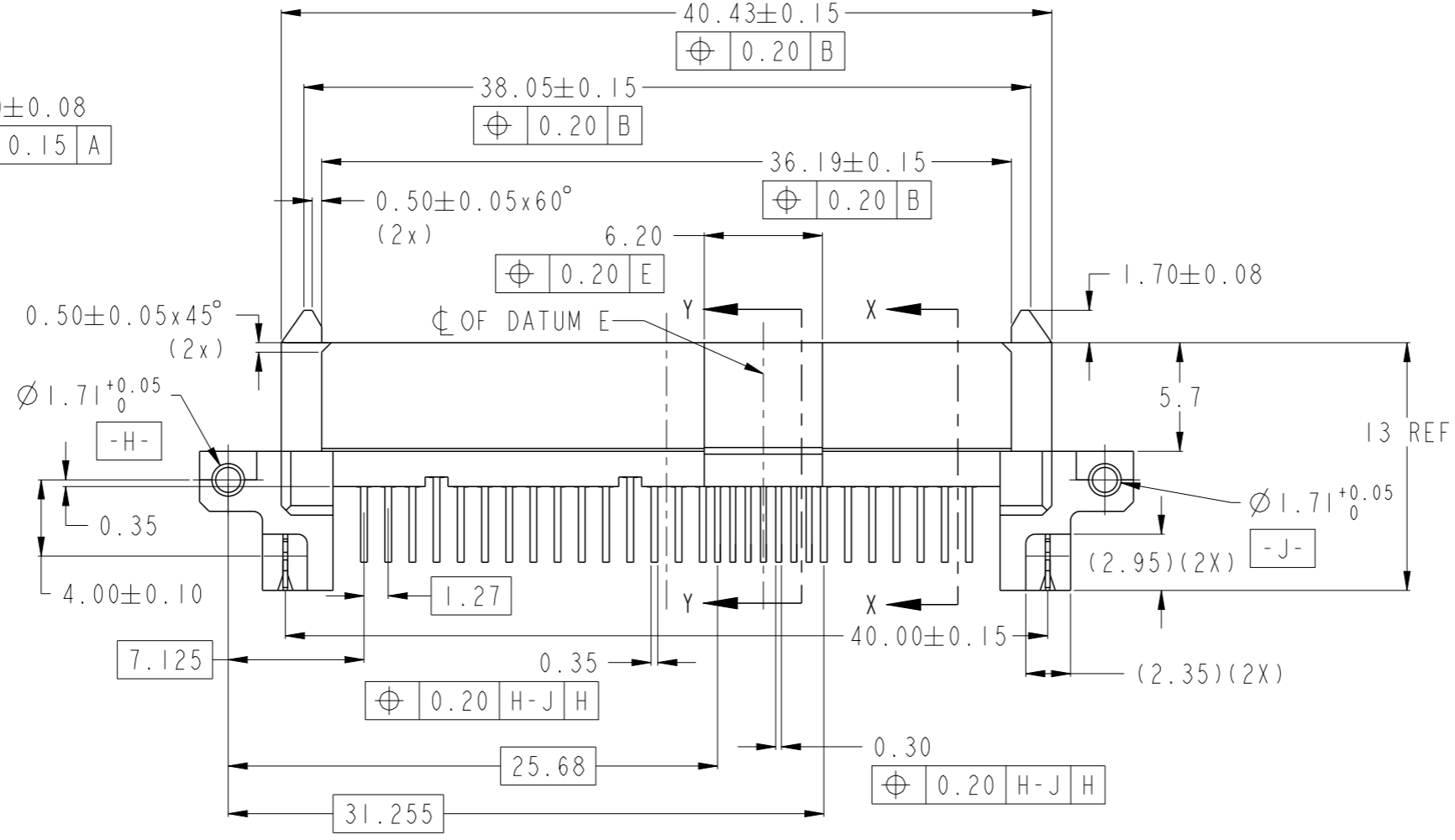
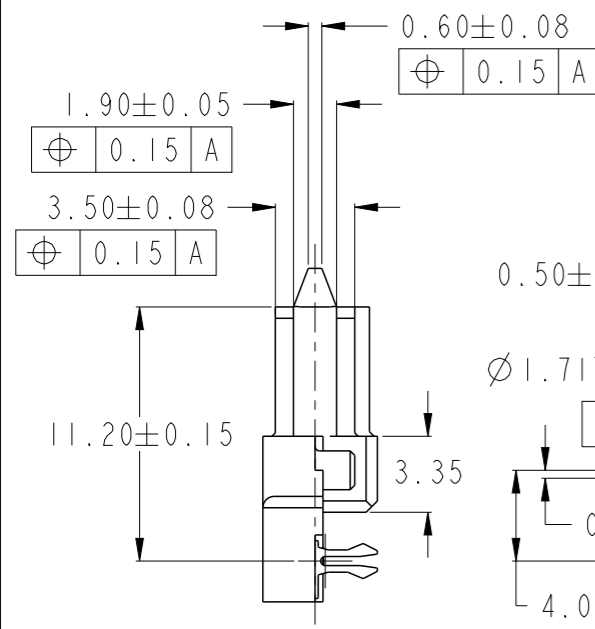

SECTION X-X

Amphenol  
FCi  
© 2016 AFCI

spec ref	dr	wcadmin	2006/03/10	projection	MM	size	A3	scale	2:1	
tolerance std	eng	Jeffrey Lim	2017/07/11			ecn no	ELX-S-27425-1			
ASME Y14.5	chr	-	rel level			Released				
TOLERANCES UNLESS OTHERWISE SPECIFIED	appr	Koon-Poh Tay	2017/07/28	product family	SAS RECEPTACLE		dwg no	10035202	rev	V
surface	linear	0.X	±	R/A SMT ASSY, Z-HT. 0.35		cat. no.	Product - Customer Drw	sheet 1 of 4		
		0.XX	±0.2							
		0.XXX	±							
	angular	0°	±2°							

PRODUCT NO.	PIN S1-S7 & P1-P15	PIN S8-S14	HOLD DOWN	PICK-UP TAPE	PACKAGING
10035202-001LF	YES	YES	METAL CLIP	NO	TRAY
10035202-001TRLF					TAPE & REEL
10035202-002LF	YES	YES	BLADE	NO	TRAY
10035202-002TRLF					TAPE & REEL
10035202-002C-TRLF					YES

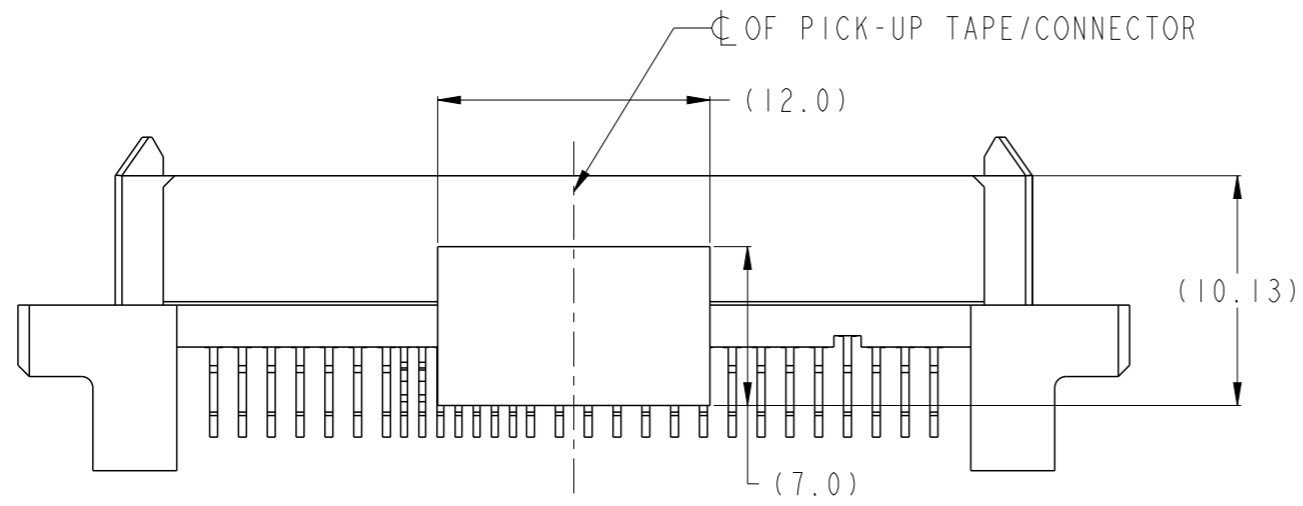

SCALE 3:1

10035202-001LF  
10035202-001TRLF

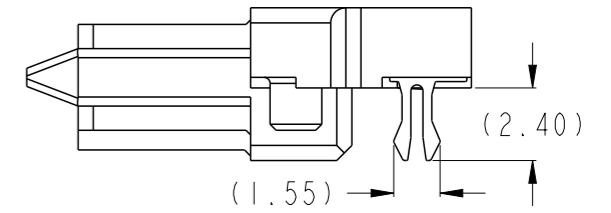

10035202-002LF  
10035202-002TRLF

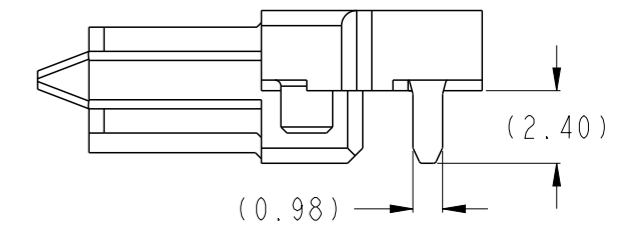

10035202-002C-TRLF

PICK-UP TAPE  
(KAPTON)

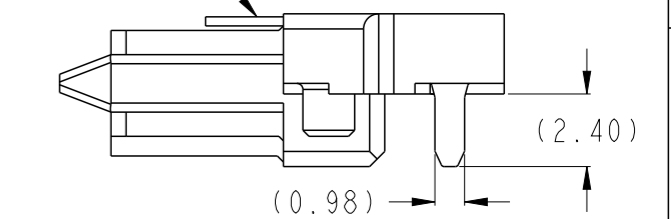

spec ref	dr	wcadmin	2006/03/10	projection	MM	size	A3	scale	2:1
tolerance std	eng	Jeffrey Lim	2017/07/11			ecn no	ELX-S-27425-1		
ASME Y14.5	chr	-	-			rel level	Released		
surface	linear	0.X	±-	<b>Amphenol FCI</b>	SAS RECEPTACLE R/A SMT ASSY, Z-HT. 0.35	dwg no 10035202	rev V		
		0.XX	±0.2						
		0.XXX	±-						
	angular	0°	±2°	cat. no.	Product - Customer Drw	sheet 2 of 4			

A

B

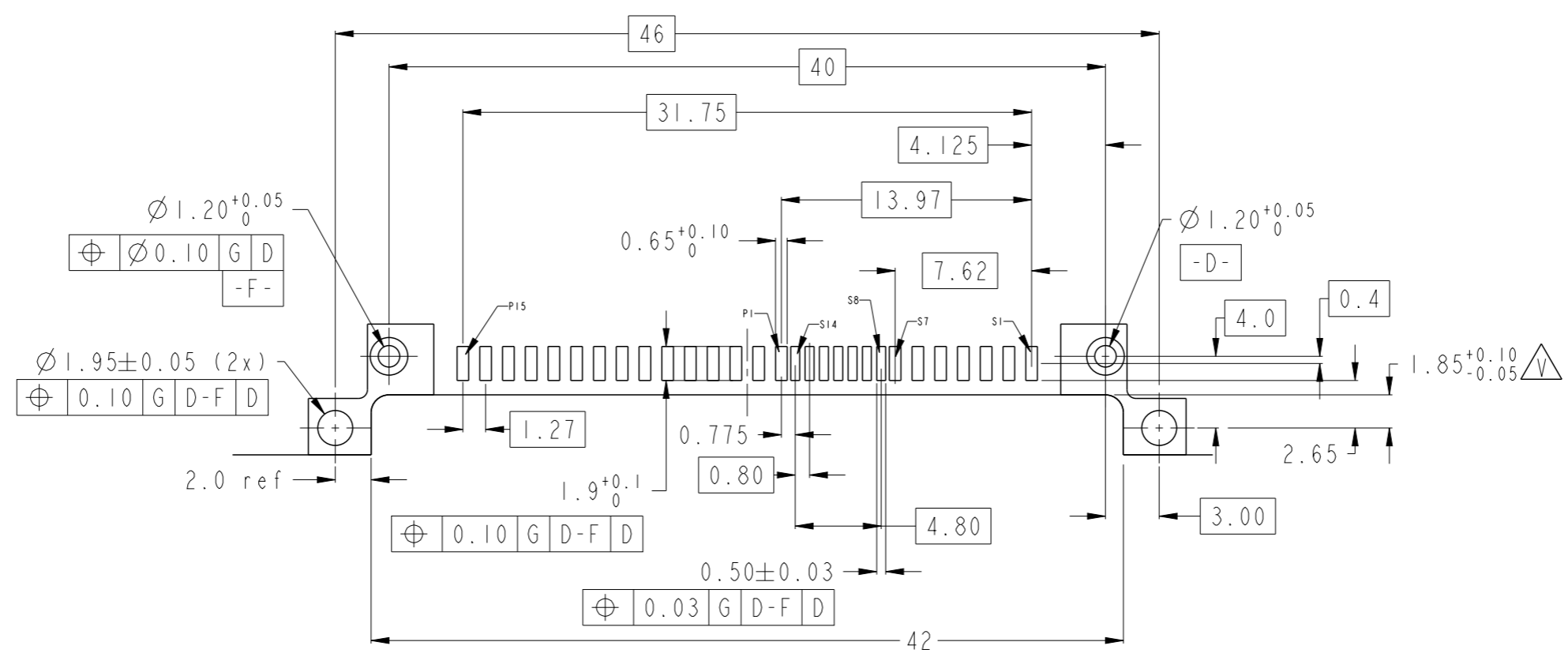

**RECOMMENDED PCB LAYOUT**  
 RECOMMENDED PCB THICKNESS: 1.6mm  
 TOLERANCE UNLESS OTHERWISE: ±0.1

C

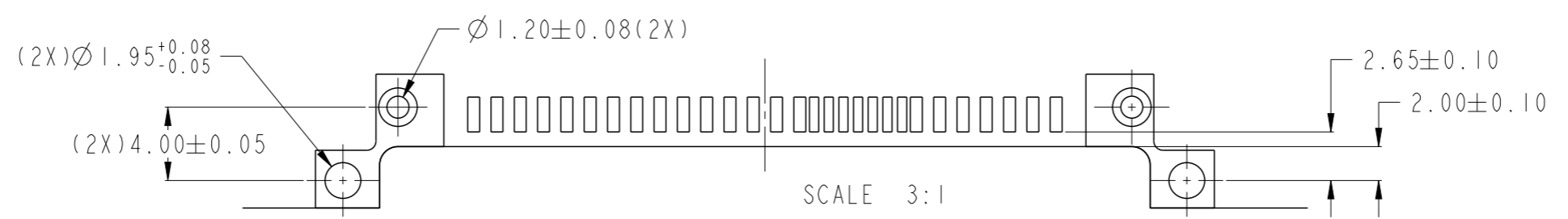

**ALTERNATIVE PCB LAYOUT**  
 REFER TO RECOMMENDED PCB LAYOUT  
 FOR UNSPECIFIED DIMENSIONS

D

spec ref	dr	wcadmin	2006/03/10	projection	MM	size	A3	scale	1:1
tolerance std	eng	Jeffrey Lim	2017/07/11			ecn no	ELX-S-27425-1		
ASME Y14.5	chr	-	rel level			Released			
surface	linear	0.X	± -	<b>Amphenol FCI</b>		SAS RECEPTACLE R/A SMT ASSY, Z-HT. 0.35	dwg no 10035202	rev V	
		0.XX	±0.2						
	angular	0°	±2°	cat. no.	-	Product - Customer Drw	sheet 3 of 4		

Amphenol FCI

© 2016 AFCI

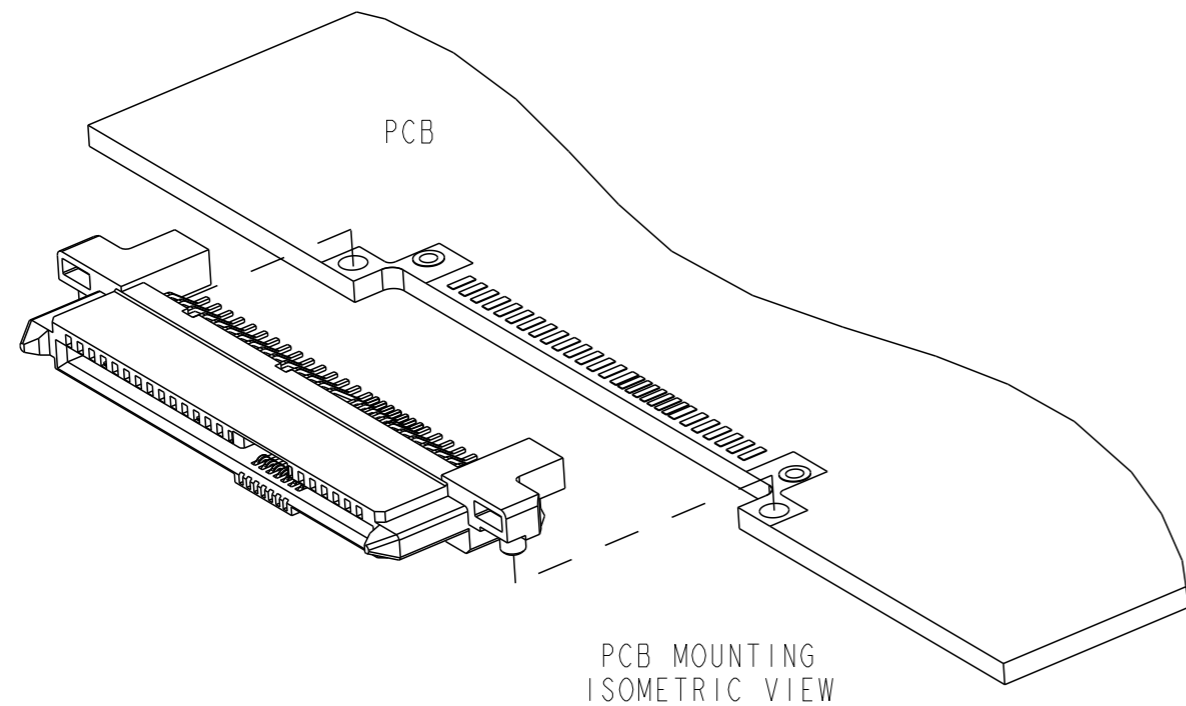

NOTES:-

1. MATERIAL:
  - 1) HOUSING: HIGH TEMP. THERMOPLASTIC, UL 94V-0  
COLOR: BLACK.
  - 2) TERMINAL: COPPER ALLOY.
  - 3) HOLD DOWN: COPPER ALLOY.
2. FINISH:
  - 1) TERMINAL: 30u" PLATING (CONTACT POINT) OVER 50u" MIN NICKEL.
  - 2) SOLDER TAIL: 100u" MIN TIN OVER 50u" MIN NICKEL.
  - 3) HOLD DOWN: 100u" MIN OVER 50u" MIN NICKEL.
3. THE STD. PACK IS IN TRAY.
4. THE HOUSING WILL WITHSTAND EXPOSURE TO 260°C PEAK TEMPERATURE FOR 10 SECONDS IN A CONVECTION, INFRA-RED OR VAPOR PHASE REFLOW OVEN.
5. THIS PRODUCT MEETS EUROPEAN UNION DIRECTIVES AND OTHER COUNTRY REGULATIONS AS DESCRIBE IN GS-47-0004
6. PART NUMBERS ENDING IN "LF" MEANT FOR NOTE 5 LEAD FREE IDENTIFICATION. P/N XXXXXXX-XXXLF IS EQUIVALENT TO PREVIOUS P/N XXXXXXX-XXX.
- 7 ALL SOLDER TAIL MUST BE WITHIN 0.10MM, MAX COPLANARITY.
- 8 THIS IS VACUUM NOZZLE PICK-UP AREA.
9. PRODUCT SPEC.: GS-12-282
10. PACKAGING SPEC.: GS-14-841 (TRAY); GS-14-966 (TAPE & REEL)
11. A SYMBOL  $\triangle V$  WILL BE NEXT TO ANY DIMENSION, VIEW, OR NOTE WHICH HAS BEEN MODIFIED WITH THE CURRENT DRAWING REVISION.

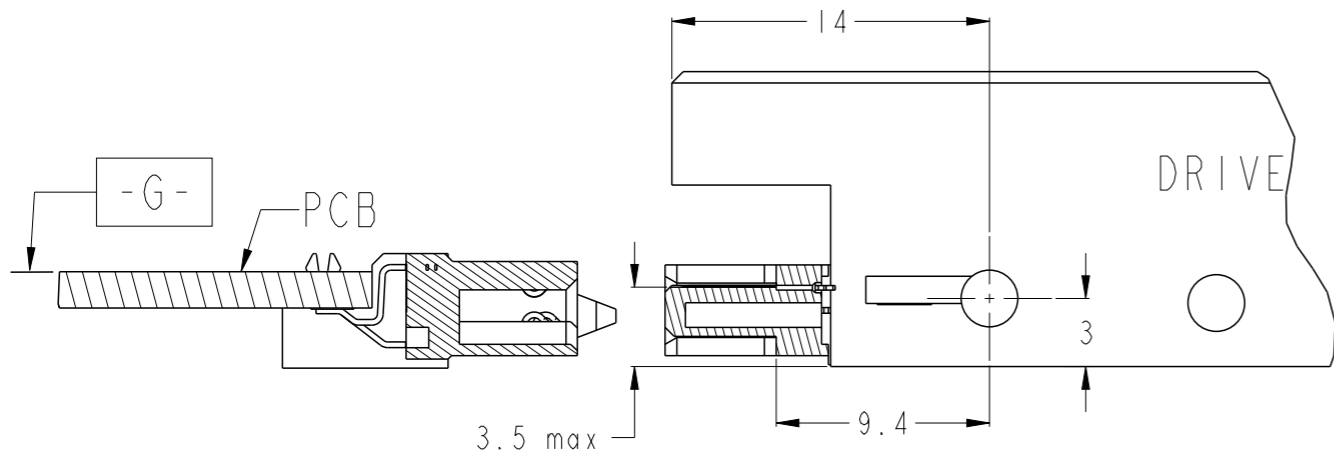

SAS Connector mounting view

spec ref	dr	wcadmin	2006/03/10	projection	MM	size	A3	scale	1:1
tolerance std	eng	Jeffrey Lim	2017/07/11			ecn no	ELX-S-27425-1		
ASME Y14.5	chr	-	rel level				Released		
surface $\checkmark$ linear angular	TOLERANCES UNLESS OTHERWISE SPECIFIED 0.X $\pm$ - 0.XX $\pm 0.2$ 0.XXX $\pm$ - 0° $\pm 2^\circ$	appr	Koon-Poh Tay	2017/07/28	product family				
		Amphenol FCI SAS RECEPTACLE R/A SMT ASSY, Z-HT. 0.35				dwg no	10035202		
		cat. no.	-			Product - Customer Drw	rev	V	
						sheet 4 of 4			

## Данный компонент на территории Российской Федерации

### Вы можете приобрести в компании MosChip.

Для оперативного оформления запроса Вам необходимо перейти по данной ссылке:

<http://moschip.ru/get-element>

Вы можете разместить у нас заказ для любого Вашего проекта, будь то серийное производство или разработка единичного прибора.

В нашем ассортименте представлены ведущие мировые производители активных и пассивных электронных компонентов.

Нашей специализацией является поставка электронной компонентной базы двойного назначения, продукции таких производителей как XILINX, Intel (ex.ALTERA), Vicor, Microchip, Texas Instruments, Analog Devices, Mini-Circuits, Amphenol, Glenair.

Сотрудничество с глобальными дистрибьюторами электронных компонентов, предоставляет возможность заказывать и получать с международных складов практически любой перечень компонентов в оптимальные для Вас сроки.

На всех этапах разработки и производства наши партнеры могут получить квалифицированную поддержку опытных инженеров.

Система менеджмента качества компании отвечает требованиям в соответствии с ГОСТ Р ИСО 9001, ГОСТ РВ 0015-002 и ЭС РД 009

### Офис по работе с юридическими лицами:

105318, г.Москва, ул.Щербаковская д.3, офис 1107, 1118, ДЦ «Щербаковский»

Телефон: +7 495 668-12-70 (многоканальный)

Факс: +7 495 668-12-70 (доб.304)

E-mail: [info@moschip.ru](mailto:info@moschip.ru)

Skype отдела продаж:

moschip.ru

moschip.ru\_4

moschip.ru\_6

moschip.ru\_9