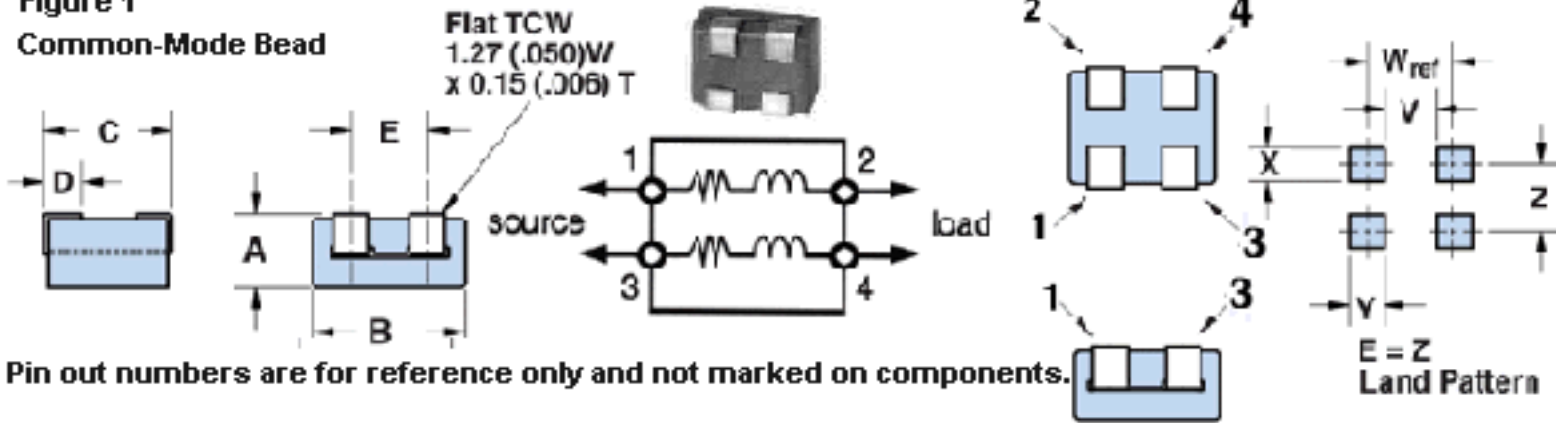



Figure 1

Common-Mode Bead



- Part Number: 2744041446
 Frequency Range: Broadband Frequencies 10-300 MHz (44 material)
 Description: 44 COMMON MODE SM BEAD
 Application: Suppression Components
 Where Used: Board Component
 Part Type: SM Beads (Common-Mode)
 Preferred Part: ✓

Mechanical Specifications

Weight: .300 (g)

Part Type Information

Surface mount common-mode beads are available from Fair-Rite in several materials and sizes. The common-mode bead provides a common magnetic path for the flux generated by the current to the load and the return current from the load. The current compensation results in zero magnetic flux in the bead.

-SM Beads on 12 mm tape width are supplied taped and reeled per EIA 481-1 and IEC 60286-3 standards. SM Beads on 16 and 24 mm tape widths are supplied taped and reeled per EIA 481-2 and IEC 60286-3 standards. Taped and reeled parts are supplied on a 13" reel.

-SM Beads can also be supplied not taped and reeled and then are bulk packed. This packing method will change the last digit of the part number to a '6'.

-The copper conductors have a lead-free tin coating.

-SM Beads meet the solderability specifications when tested in accordance with MIL-STD-202, method 208. After dipping the mounting site of the bead, the solder surface shall be at least 95% covered with a smooth solder coating. The edges of the copper strip are not specified as solderable surfaces.

-After preheating the beads to within 100 oC of the soldering temperature, the parts meet the resistance to soldering requirements of EIA-186-10E, temperature 260±5 oC and time 10±1 seconds.

-Suggested land patterns are in accordance with the latest revision of IPC-7351.

-SM Beads are controlled for impedance limits only. The impedances listed are typical values. Minimum impedance values are specified for the + marked frequencies. The minimum guaranteed impedance is the listed value less 20%. SM Beads in 44 materials are measured for impedance on the 4193 Vector Impedance Analyzer. The 52 SM Beads are tested for impedance on the 4191A RF Impedance Analyzer.

-Recommended storage and operation temperature is -55 oC to 125 oC.

-The maximum current rating for these SM Beads is 5 amps.

-For any SM Bead requirement not listed, please contact our customer service group for availability and pricing.

-Our Surface Mount Bead Kit' (part number 0199000025) is available for prototype evaluation.

-Explanation of Part Numbers: Digits 1&2 = product class, 3&4 = material grade, last digit 6 = bulk packed, 7 = taped and reeled.



Fair-Rite Products Corp.

Your Signal Solution®

Ferrite Components for the Electronics Industry

Fair-Rite Products Corp. PO Box J, One Commercial Row, Wallkill, NY 12589-0288
Phone: (888) 324-7748 www.fair-rite.com

Fair-Rite Product's Catalog
Part Data Sheet, 2744041446
Printed: 2010-11-09



Mechanical Specifications

| Dim | mm | mm tol | nominal inch | inch misc. |
|-----|------|-----------|-----------------|---------------|
| A | 2.85 | ±0.20 | 0.112 | - |
| B | 5.60 | ±0.20 | 0.220 | - |
| C | 5.00 | -0.60 | 0.185 | - |
| D | 1.35 | ±0.50 | 0.053 | - |
| E | 2.54 | ±0.10 | 0.100 | - |
| F | - | - | - | - |
| G | - | - | - | - |
| H | - | - | - | - |
| J | - | - | - | - |
| K | - | - | - | - |

Electrical Specifications

| Typical Impedance (Ω) | |
|--------------------------------|----|
| 10 MHz | 12 |
| 25 MHz+ | 20 |
| 100 MHz+ | 33 |
| 250 MHz | 41 |
| 300 MHz | - |

| Electrical Properties | |
|-----------------------|------|
| Max Rdc(m Ω) | 1.10 |

Land Patterns

| V | W ref | X | Y | Z |
|----------------|----------------|----------------|----------------|----------------|
| 1.000 0.040 | 4.000 0.158 | 1.800 0.071 | 3.000 0.118 | 2.540 0.100 |

Winding Information

| Turns Tested | Wire Size | 1st Wire Length | 2nd Wire Length |
|-----------------|--------------|--------------------|--------------------|
| - | - | - | - |

Reel Information

| Tape Width mm | Pitch mm | Parts 7 " Reel | Parts 13 " Reel | Parts 14 " Reel |
|------------------|-------------|-------------------|--------------------|--------------------|
| - | - | - | - | - |

Package Size

| Pkg Size |
|----------|
| - (-) |

Connector Plate

| # Holes | # Rows |
|---------|--------|
| - | - |

Legend

+ Test frequency

Preferred parts, the suggested choice for new designs, have shorter lead times and are more readily available.

The column H(Oe) gives for each bead the calculated dc bias field in oersted for 1 turn and 1 ampere direct current. The actual dc H field in the application is this value of H times the actual NI (ampere-turn) product. For the effect of the dc bias on the impedance of the bead material, see figures 18-23 in the application note How to choose Ferrite Components for EMI Suppression.

A ½ turn is defined as a single pass through a hole.

Σ l/A - Core Constant

A_e - Effective Cross-Sectional Area

A_L - Inductance Factor ($\frac{L}{N^2}$)

N/AWG - Number of Turns/Wire Size for Test Coil

l_e - Effective Path Length

V_e - Effective Core Volume

NI - Value of dc Ampere-turns



Ferrite Material Constants

| | |
|---------------------------------------|--|
| Specific Heat | 0.25 cal/g/°C |
| Thermal Conductivity | 10x10 ⁻³ cal/sec/cm/°C |
| Coefficient of Linear Expansion | 8 - 10x10 ⁻⁶ /°C |
| Tensile Strength | 4.9 kgf/mm ² |
| Compressive Strength | 42 kgf/mm ² |
| Young's Modulus | 15x10 ³ kgf/mm ² |
| Hardness (Knoop) | 650 |
| Specific Gravity | ≈ 4.7 g/cm ³ |

The above quoted properties are typical for Fair-Rite MnZn and NiZn ferrites.

See next page for further material specifications.



44 Material Characteristics:

| Property | Unit | Symbol | Value |
|--|------------------|---------------------|-----------------|
| Initial Permeability @ B < 10 gauss | | μ_i | 500 |
| Flux Density @ Field Strength | gauss oersted | B H | 3000 10 |
| Residual Flux Density | gauss | B_r | 1100 |
| Coercive Force | oersted | H_c | 0.45 |
| Loss Factor @ Frequency | 10^{-6} MHz | $\tan \delta \mu_i$ | 125 1.0 |
| Temperature Coefficient of Initial Permeability (20 -70°C) | %/°C | | 0.75 |
| Curie Temperature | °C | T_c | >160 |
| Resistivity | Ω cm | ρ | 1×10^9 |

Complex Permeability vs. Frequency

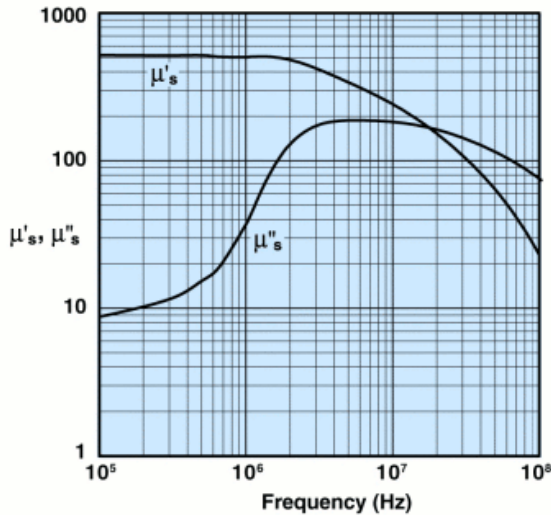

Measured on a 17/10/6mm toroid using the HP 4284A and the HP 4291A.

Percent of Original Impedance vs. Temperature

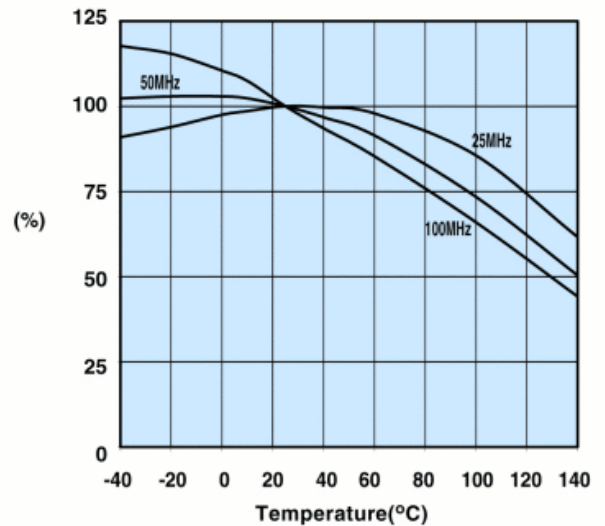

Measured on a 2644000301 using the HP4291A.

Initial Permeability vs. Temperature

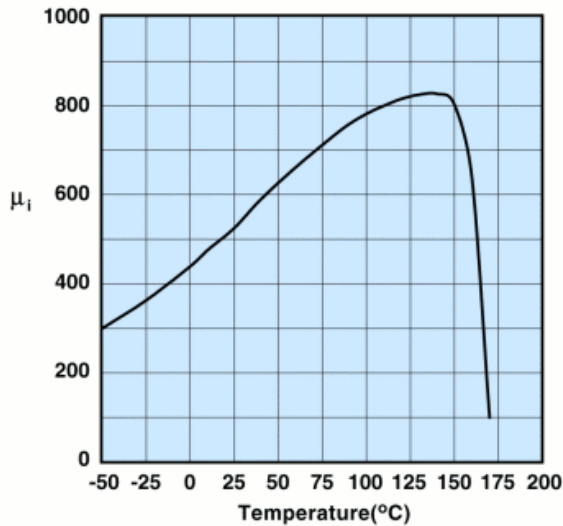

Measured on a 17/10/6mm toroid at 100kHz.

Hysteresis Loop

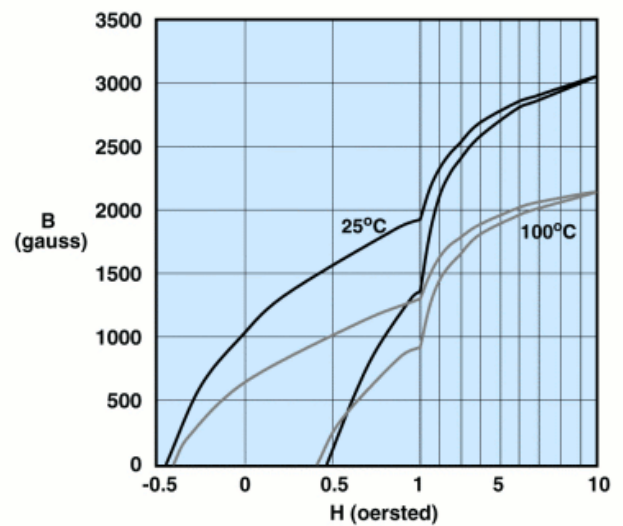

Measured on a 17/10/6mm toroid at 10kHz.



2744041446

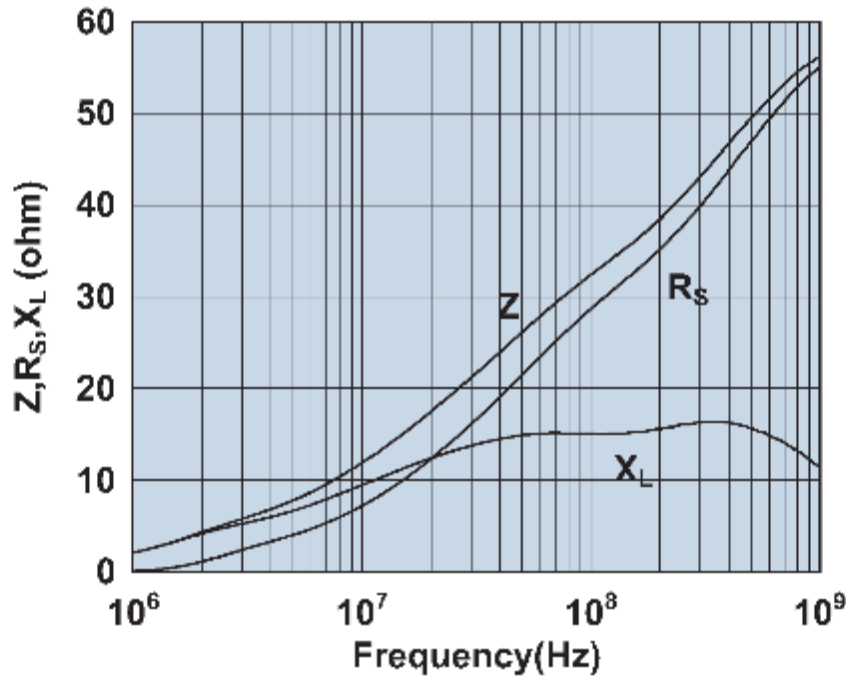

Impedance, reactance, and resistance vs. frequency.

Данный компонент на территории Российской Федерации

Вы можете приобрести в компании MosChip.

Для оперативного оформления запроса Вам необходимо перейти по данной ссылке:

<http://moschip.ru/get-element>

Вы можете разместить у нас заказ для любого Вашего проекта, будь то серийное производство или разработка единичного прибора.

В нашем ассортименте представлены ведущие мировые производители активных и пассивных электронных компонентов.

Нашей специализацией является поставка электронной компонентной базы двойного назначения, продукции таких производителей как XILINX, Intel (ex.ALTERA), Vicor, Microchip, Texas Instruments, Analog Devices, Mini-Circuits, Amphenol, Glenair.

Сотрудничество с глобальными дистрибьюторами электронных компонентов, предоставляет возможность заказывать и получать с международных складов практически любой перечень компонентов в оптимальные для Вас сроки.

На всех этапах разработки и производства наши партнеры могут получить квалифицированную поддержку опытных инженеров.

Система менеджмента качества компании отвечает требованиям в соответствии с ГОСТ Р ИСО 9001, ГОСТ РВ 0015-002 и ЭС РД 009

Офис по работе с юридическими лицами:

105318, г.Москва, ул.Щербаковская д.3, офис 1107, 1118, ДЦ «Щербаковский»

Телефон: +7 495 668-12-70 (многоканальный)

Факс: +7 495 668-12-70 (доб.304)

E-mail: info@moschip.ru

Skype отдела продаж:

moschip.ru

moschip.ru_4

moschip.ru_6

moschip.ru_9