

FEATURES

Analog I/O

- Multichannel, 12-bit, 1 MSPS ADC
 - Up to 14 analog-to-digital converter (ADC) channels
 - Fully differential and single-ended modes
 - 0 to V_{REF} analog input range
- 10-bit digital-to-analog converter (DAC)
 - 32-bit 21 MHz direct digital synthesis (DDS)
 - Current-to-voltage (I/V) conversion
 - Integrated second-order low-pass filter (LPF)
 - DDS input to DAC
 - 100 Ω line driver

- On-chip voltage reference
- On-chip temperature sensor ($\pm 3^{\circ}\text{C}$)
- Voltage comparator

Microcontroller

- ARM7TDMI core, 16-/32-bit RISC architecture
- JTAG port supports code download and debug
- External watch crystal/clock source
 - 41.78 MHz PLL with 8-way programmable divider
 - Optional trimmed on-chip oscillator

Memory

- 126 kB Flash/EE memory, 8 kB SRAM

- In-circuit download, JTAG-based debug
- Software triggered in-circuit reprogrammability

On-chip peripherals

- 2 \times UART, 2 \times I²C and SPI serial I/O
- Up to 40-pin GPIO port
- 5 \times general-purpose timers
- Wake-up and watchdog timers (WDT)
- Power supply monitor
- 16-bit PWM generator
- Quadrature encoder
- Programmable logic array (PLA)

Power

- Specified for 3 V operation
- Active mode
 - 11 mA (@ 5.22 MHz)
 - 45 mA (@ 41.78 MHz)

Packages and temperature range

- 64-lead 9 mm \times 9 mm LFCSP package, -40°C to 125°C
- 64-lead LQFP, -40°C to $+125^{\circ}\text{C}$
- 80-lead LQFP, -40°C to $+125^{\circ}\text{C}$

Tools

- Low cost QuickStart development system
- Full third-party support

FUNCTIONAL BLOCK DIAGRAM

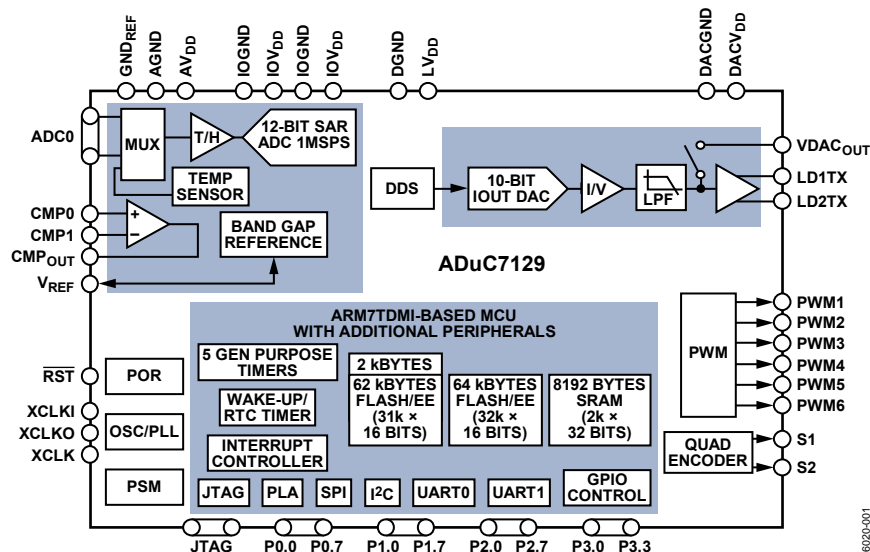

Figure 1.

Rev. 0

Information furnished by Analog Devices is believed to be accurate and reliable. However, no responsibility is assumed by Analog Devices for its use, nor for any infringements of patents or other rights of third parties that may result from its use. Specifications subject to change without notice. No license is granted by implication or otherwise under any patent or patent rights of Analog Devices. Trademarks and registered trademarks are the property of their respective owners.

TABLE OF CONTENTS

Features	1	Execution Time from SRAM and FLASH/EE	43
Functional Block Diagram	1	Reset and Remap	44
Revision History	2	Other Analog Peripherals.....	45
General Description	3	DAC.....	45
Specifications.....	4	DDS	46
Timing Specifications	8	Power Supply Monitor	47
Absolute Maximum Ratings.....	15	Comparator	47
ESD Caution.....	15	Oscillator and PLL—Power Control.....	49
Pin Configuration and Function Descriptions.....	16	Digital Peripherals.....	51
Typical Performance Characteristics	21	PWM General Overview.....	51
Terminology	24	PWM Convert Start Control	52
ADC Specifications	24	General-Purpose I/O	55
DAC Specifications.....	24	Serial Port Mux.....	57
Overview of the ARM7TDMI Core.....	25	UART Serial Interface.....	57
Thumb Mode (T).....	25	Serial Peripheral Interface.....	63
Long Multiply (M).....	25	I ² C-Compatible Interfaces.....	65
EmbeddedICE (I)	25	I ² C Registers	65
Exceptions	25	Programmable Logic Array (PLA).....	69
ARM Registers	25	Processor Reference Peripherals.....	72
Interrupt Latency.....	26	Interrupt System	72
Memory Organization	27	Timers	73
Flash/EE Memory.....	27	Timer0—Lifetime Timer	73
SRAM.....	27	Timer1—General-Purpose Timer	75
Memory Mapped Registers	27	Timer2—Wake-Up Timer	77
Complete MMR Listing.....	28	Timer3—Watchdog Timer	79
ADC Circuit Overview	32	Timer4—General-Purpose Timer	81
ADC Transfer Function.....	32	External Memory Interfacing	83
Typical Operation.....	33	Timing Diagrams	84
Converter Operation.....	36	Hardware Design Considerations	87
Driving the Analog Inputs	37	Power Supplies.....	87
Temperature Sensor	37	Grounding and Board Layout Recommendations.....	87
Band Gap Reference	38	Clock Oscillator	88
Nonvolatile Flash/EE Memory	39	Power-On Reset Operation.....	89
Flash/EE Memory Overview.....	39	Development Tools.....	90
Flash/EE Memory.....	39	In-Circuit Serial Downloader.....	90
Flash/EE Memory Security	40	Outline Dimensions	91
Flash/EE Control Interface.....	40	Ordering Guide	92

REVISION HISTORY

4/07—Revision 0: Initial Version

GENERAL DESCRIPTION

The ADuC7128/ADuC7129 are fully integrated, 1 MSPS, 12-bit data acquisition systems incorporating a high performance, multi-channel analog-to-digital converter (ADC), DDS with line driver, 16-/32-bit MCU, and Flash/EE memory on a single chip.

The ADC consists of up to 14 single-ended inputs. The ADC can operate in single-ended or differential input modes. The ADC input voltage is 0 to V_{REF} . Low drift band gap reference, temperature sensor, and voltage comparator complete the ADC peripheral set.

The ADuC7128/ADuC7129 integrate a differential line driver output. This line driver transmits a sine wave whose values are calculated by an on-chip DDS or a voltage output determined by the DACDAT MMR.

The devices operate from an on-chip oscillator and PLL, generating an internal high frequency clock of 41.78 MHz. This clock is routed through a programmable clock divider from which the MCU core clock operating frequency is generated.

The microcontroller core is an ARM7TDMI®, 16-/32-bit reduced instruction set computer (RISC), offering up to 41 MIPS peak performance. There are 126 kB of nonvolatile Flash/EE provided on-chip, as well as 8 kB of SRAM. The ARM7TDMI core views all memory and registers as a single linear array.

On-chip factory firmware supports in-circuit serial download via the UART serial interface port, and nonintrusive emulation is also supported via the JTAG interface. These features are incorporated into a low cost QuickStart™ development system supporting this MicroConverter® family.

The parts operate from 3.0 V to 3.6 V and are specified over an industrial temperature range of -40°C to $+125^{\circ}\text{C}$. When operating at 41.78 MHz, the power dissipation is 135 mW. The line driver output, if enabled, consumes an additional 30 mW.

ADuC7128/ADuC7129

SPECIFICATIONS

$AV_{DD} = IOV_{DD} = 3.0\text{ V to }3.6\text{ V}$, $V_{REF} = 2.5\text{ V}$ internal reference, $f_{CORE} = 41.78\text{ MHz}$. All specifications $T_A = T_{MAX}$ to T_{MIN} , unless otherwise noted.

Table 1.

Parameter	Min	Typ	Max	Unit	Test Conditions/Comments
ADC CHANNEL SPECIFICATIONS					
ADC Power-Up Time		5		μs	Eight acquisition clocks and $f_{ADC}/2$
DC Accuracy ^{1,2}					
Resolution	12			Bits	
Integral Nonlinearity ³		± 0.7	± 2.0	LSB	2.5 V internal reference 85°C to 125°C only
		± 0.7	± 1.5	LSB	2.5 V internal reference -40°C to +85°C
		± 2.0		LSB	1.0 V external reference
Differential Nonlinearity ³		± 0.5	+1/-0.9	LSB	2.5 V internal reference
		± 0.6		LSB	1.0 V external reference
DC Code Distribution		1		LSB	ADC input is a dc voltage
ENDPOINT ERRORS⁴					
Offset Error			± 5	LSB	
Offset Error Match		± 1		LSB	
Gain Error			± 5	LSB	
Gain Error Match		± 1		LSB	
DYNAMIC PERFORMANCE					
Signal-to-Noise Ratio (SNR)		69		dB	$F_{IN} = 10\text{ kHz sine wave}$, $f_{SAMPLE} = 1\text{ MSPS}$
Total Harmonic Distortion (THD)		-78		dB	
Peak Harmonic or Spurious Noise		-75		dB	
Channel-to-Channel Crosstalk		-80		dB	
Crosstalk Between Channel 12 and Channel 13		-60		dB	
ANALOG INPUT					
Input Voltage Ranges					
Differential Mode ⁵			$V_{CM} \pm V_{REF}/2$	V	
Single-Ended Mode			0 to V_{REF}	V	
Leakage Current			± 15	μA	85°C to 125°C only
		± 1	± 3	μA	-40°C to +85°C
Input Capacitance		20		pF	During ADC acquisition
ON-CHIP VOLTAGE REFERENCE					
Output Voltage		2.5		V	0.47 μF from V_{REF} to AGND
Accuracy			± 2.5	mV	Measured at $T_A = 25^\circ\text{C}$
Reference Drop When DAC Enabled		9		mV	Reference drop when DAC enabled
Reference Temperature Coefficient		± 40		ppm/ $^\circ\text{C}$	
Power Supply Rejection Ratio		80		dB	
Output Impedance		40		Ω	
Internal V_{REF} Power-On Time		1		ms	
EXTERNAL REFERENCE INPUT⁶					
Input Voltage Range	0.625		AV_{DD}	V	
Input Impedance		38		k Ω	
DAC CHANNEL SPECIFICATIONS					
VDAC Output					$R_L = 5\text{ k}\Omega$, $C_L = 100\text{ pF}$
Voltage Swing		$(0.33 \times V_{REF} \pm 0.2 \times V_{REF}) \times 1.33$			V_{REF} is the internal 2.5 V reference
I/V Output Resistance			7	Ω	V mode selected
Low-Pass Filter 3 dB Point		1		MHz	2-pole at 1.5 MHz and 2 MHz
Resolution		10		Bits	

Parameter	Min	Typ	Max	Unit	Test Conditions/Comments
Relative Accuracy		±2		LSB	
Differential Nonlinearity, +VE		0.35		LSB	
Differential Nonlinearity, -VE		-0.15		LSB	
Offset Error			-190	mV	
Gain Error			+150	mV	
Voltage Output Settling Time to 0.1%			5	µs	
Line Driver Output					As measured into a range of specified loads (see Figure 2) at LD1TX and LD2TX, unless otherwise noted
Total Harmonic Distortion		-52		dB	PLM operating at 691.2 kHz
Output Voltage Swing		±1.768		V rms	
COMMON MODE					
AC Mode		1.65		V	Each output has a common mode of $0.5 V \times AV_{DD}$ and swings $0.5 V \times V_{REF}$ above and below this; V_{REF} is the internal 2.5 V reference
DC Mode		1.5		V	Each output has a common mode of $0.5 V \times V_{REF}$ and swings $0.6 V \times V_{REF}$ above and below this; V_{REF} is the internal 2.5 V reference
DIFFERENTIAL INPUT IMPEDANCE					
Leakage Current LD1TX, LD2TX	11	13	7	kΩ	Line driver buffer disabled
Short-Circuit Current		±50		µA	Line driver buffer disabled
Line Driver Tx Power-Up Time			20	mA	No protection diodes, max allowable current
				µs	
COMPARATOR					
Input Offset Voltage		±15		mV	
Input Bias Current		1		µA	
Input Voltage Range	AGND		$AV_{DD} - 1.2 V$		
Input Capacitance		7		pF	
Hysteresis ^{3,5}	2		15	mV	Hysteresis can be turned on or off via the CMPHYST bit in the CMPCON register
Response Time		1		µs	Response time can be modified via the CMPRES bits in the CMPCON register
TEMPERATURE SENSOR					
Voltage Output at 25°C		780		mV	
Voltage Temperature Coefficient		-1.3		mV/°C	
Accuracy		±3		°C	
POWER SUPPLY MONITOR (PSM)					
IOV _{DD} Trip Point Selection		2.79		V	Two selectable trip points
		3.07		V	
Power Supply Trip Point Accuracy		±2.5		%	Of the selected nominal trip point voltage
GLITCH IMMUNITY ON \overline{RST} PIN ³		50		µs	
WATCHDOG TIMER (WDT)					
Timeout Period	0		512	ms	
				sec	
FLASH/EE MEMORY^{7,8}					
Endurance	10,000			Cycles	
Data Retention	20			Years	$T_J = 85^\circ C$
DIGITAL INPUTS					
Logic 1 Input Current (Leakage Current)		±0.2	±1	µA	All digital inputs, including XCLKI and XCLKO $V_{INH} = V_{DD}$ or $V_{INH} = 5 V$
Logic 0 Input Current (Leakage Current)		-40	-65	µA	$V_{INL} = 0 V$, except TDI
		-80	+125	µA	$V_{INL} = 0 V$, TDI Only
Input Capacitance		15		pF	

ADuC7128/ADuC7129

Parameter	Min	Typ	Max	Unit	Test Conditions/Comments
LOGIC INPUTS ³					All logic inputs, including XCLKI and XCLKO
V _{INL} , Input Low Voltage			0.8	V	
V _{INH} , Input High Voltage	2.0			V	
Quadrature Encoder Inputs S1/S2/CLR (Schmitt-Triggered Inputs)					
V _{T+}		1.65		V	
V _{T-}		1.2		V	
V _{T+} – V _{T-}		0.75		V	
LOGIC OUTPUTS ⁹					
V _{OH} , Output High Voltage	I _O V _{DD} – 400 mV			V	I _{SOURCE} = 1.6 mA
V _{OL} , Output Low Voltage			0.4	V	I _{SINK} = 1.6 mA
CRYSTAL INPUTS XCLKI and XCLKO					
V _{INL} , Input Low Voltage		1.1		V	Logic inputs, XCLKI only
V _{INH} , Input High Voltage		1.7		V	Logic inputs, XCLKI only
XCLKI, Input Capacitance		20		pF	
XCLKO, Output Capacitance		20		pF	
MCU CLOCK RATE (PLL)					
	326.4		41.77920	kHz MHz	Eight programmable core clock selections within this range (32.768 kHz x 1275)/128 (32.768 kHz x 1275)/1
INTERNAL OSCILLATOR		32.768		kHz	
Tolerance			±3	%	–40°C to 85°C
			±4	%	85°C to 125°C only
STARTUP TIME					Core clock = 41.78 MHz
At Power-On		70		ms	
From Sleep Mode		1.6		ms	
From Stop Mode		1.6		ms	
PROGRAMMABLE LOGIC ARRAY (PLA)					
Pin Propagation Delay		12		ns	From input pin to output pin
Element Propagation Delay		2.5		ns	
POWER REQUIREMENTS					
Power Supply Voltage Range					
I _O V _{DD} , AV _{DD} , and DACV _{DD} (Supply Voltage to Chip)	3.0		3.6	V	
LV _{DD} (Regulator Output from Chip)	2.5	2.6	2.7	V	
Power Supply Current ^{10, 11}					
Normal Mode		15	19	mA	5.22 MHz clock
		42	49	mA	41.78 MHz clock
Additional Line Driver Tx Supply Current			30	mA	691 kHz, maximum load (see Figure 2)
Pause Mode			37	mA	41.78 MHz clock
Sleep Mode		0.3	3.6	mA	External crystal or internal OSC ON

¹ All ADC channel specifications are guaranteed during normal MicroConverter core operation.

² Apply to all ADC input channels.

³ Not production tested; supported by design and/or characterization of data on production release.

⁴ Measured using an external AD845 op amp as an input buffer stage, as shown in Figure 42. Based on external ADC system components.

⁵ The input signal can be centered on any dc common-mode voltage (V_{CM}), as long as this value is within the ADC voltage input range specified.

⁶ When using an external reference input pin, the internal reference must be disabled by setting the LSB in the REFCON memory mapped register to 0.

⁷ Endurance is qualified as per JEDEC Std. 22 Method A117 and measured at –40°C, +25°C, and +85°C.

⁸ Retention lifetime equivalent at junction temperature (T_J) = 85°C as per JEDEC Std. 22 Method A117. Retention lifetime derates with junction temperature.

⁹ Test carried out with a maximum of eight I/Os set to a low output level.

¹⁰ Power supply current consumption is measured in normal, pause, and sleep modes under the following conditions: normal mode = 3.6 V supply, pause mode = 3.6 V supply, sleep mode = 3.6 V supply.

¹¹ I_OV_{DD} power supply current decreases typically by 2 mA during a Flash/EE erase cycle.

Line Driver Load



Figure 2. Line Driver Load Minimum (Top) and Maximum (Bottom)

ADuC7128/ADuC7129

TIMING SPECIFICATIONS

Table 2. External Memory Write Cycle

Parameter	Min	Typ	Max	Unit
CLK		UCLK		
$t_{MS_AFTER_CLKH}$	0		4	ns
$t_{ADDR_AFTER_CLKH}$	4		8	ns
$t_{AE_H_AFTER_MS}$		$\frac{1}{2}$ CLK		
t_{AE}		$(XMxPAR[14:12] + 1) \times CLK$		
$t_{HOLD_ADDR_AFTER_AE_L}$		$\frac{1}{2} CLK + (!XMxPAR[10]) \times CLK$		
$t_{HOLD_ADDR_BEFORE_WR_L}$		$(!XMxPAR[8]) \times CLK$		
$t_{WR_L_AFTER_AE_L}$		$\frac{1}{2} CLK + (!XMxPAR[10] + !XMxPAR[8]) \times CLK$		
$t_{DATA_AFTER_WR_L}$	8		12	ns
t_{WR}		$(XMxPAR[7:4] + 1) \times CLK$		
$t_{WR_H_AFTER_CLKH}$	0		4	ns
$t_{HOLD_DATA_AFTER_WR_H}$		$(!XMxPAR[8]) \times CLK$		
$t_{BEN_AFTER_AE_L}$		$\frac{1}{2}$ CLK		
$t_{RELEASE_MS_AFTER_WR_H}$		$(!XMxPAR[8] + 1) \times CLK$		



Figure 3. External Memory Write Cycle

Table 3. External Memory Read Cycle

Parameter	Min	Typ	Max	Unit
CLK	1/MD Clock	ns typ × (CDPOWCON[2:0] + 1)		
t _{MS_AFTER_CLKH}	4		8	ns
t _{ADDR_AFTER_CLKH}	4		16	ns
t _{AE_H_AFTER_MS}		½ CLK		
t _{AE}		(XMxPAR[14:12] + 1) × CLK		
t _{HOLD_ADDR_AFTER_AE_L}		½ CLK + (! XMxPAR[10]) × CLK		
t _{RD_L_AFTER_AE_L}		½ CLK + (! XMxPAR[10] + ! XMxPAR[9]) × CLK		
t _{RD_H_AFTER_CLKH}	0		4	ns
t _{RD}		(XMxPAR[3:0] + 1) × CLK		
t _{DATA_BEFORE_RD_H}	16			ns
t _{DATA_AFTER_RD_H}	8	+ (! XMxPAR[9]) × CLK		
t _{RELEASE_WS_AFTER_RD_H}		1 × CLK		

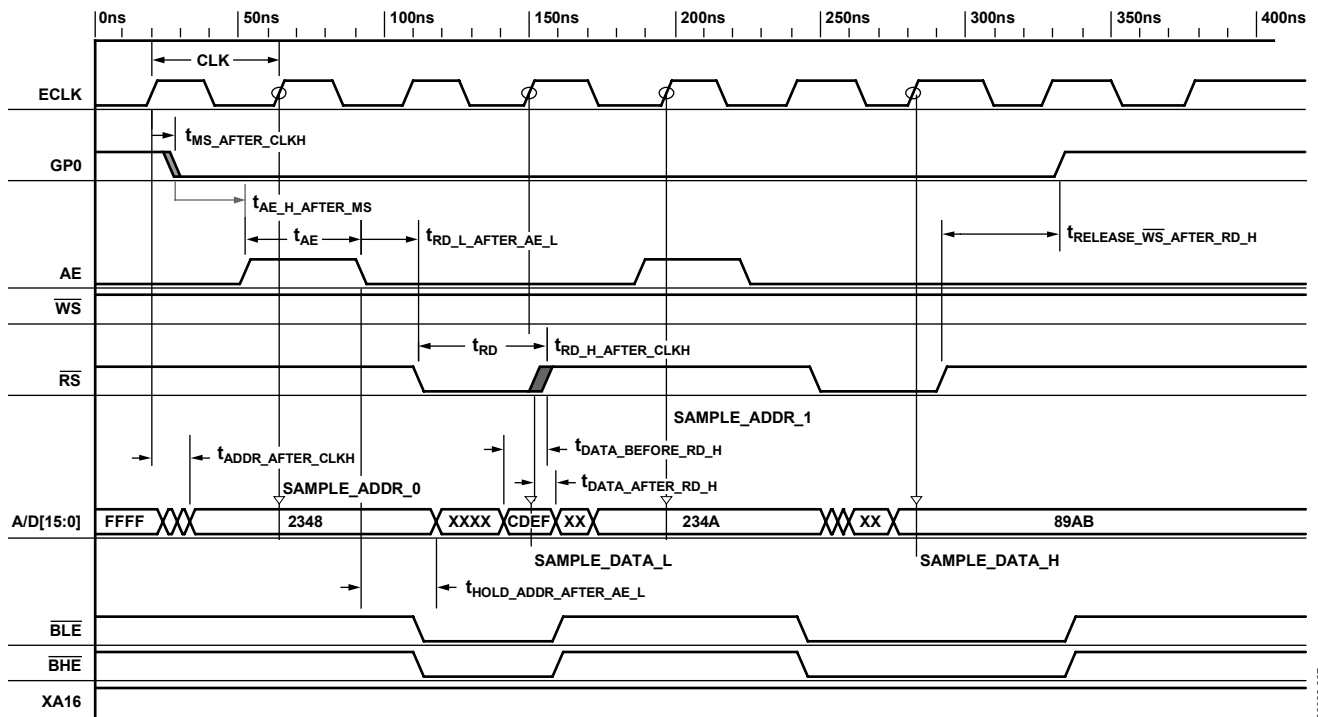

Figure 4. External Memory Read Cycle

06620-087

ADuC7128/ADuC7129

I²C® Timing Specifications

Table 4. I²C Timing in Fast Mode (400 kHz)

Parameter	Description	Slave Min	Slave Max	Master Typ	Unit
t _L	SCLOCK low pulse width ¹	200		1360	ns
t _H	SCLOCK high pulse width ¹	100		1140	ns
t _{SHD}	Start condition hold time	300		251,350	ns
t _{DSU}	Data setup time	100		740	ns
t _{DHD}	Data hold time	0		400	ns
t _{RSU}	Setup time for repeated start	100		12.51350	ns
t _{PSU}	Stop condition setup time	100		400	ns
t _{BUF}	Bus-free time between a stop condition and a start condition	1.3			μs
t _R	Rise time for both SCLOCK and SDATA	100	300	200	ns
t _F	Fall time for both SCLOCK and SDATA	60	300	20	ns
t _{SUP}	Pulse width of spike suppressed		50		ns

¹ t_{HCLK} depends on the clock divider or CD bits in the PLLCON MMR, t_{HCLK} = t_{UCLK}/2^{CD}.

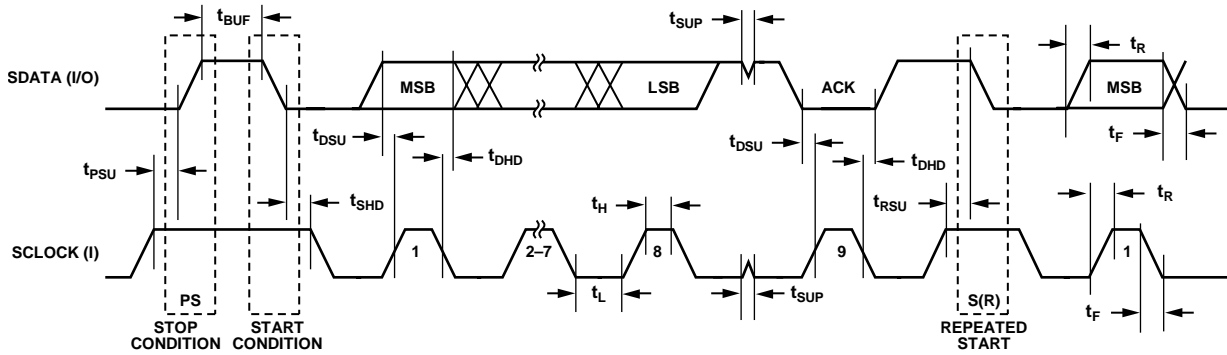

Figure 5. I²C-Compatible Interface Timing

06/20-003

SPI Timing Specifications

Table 5. SPI Master Mode Timing (PHASE Mode = 1)

Parameter	Description	Min	Typ	Max	Unit
t _{SL}	SCLOCK low pulse width ¹		(SPIDIV + 1) × t _{HCLK}		ns
t _{SH}	SCLOCK high pulse width ¹		(SPIDIV + 1) × t _{HCLK}		ns
t _{DAV}	Data output valid after SCLOCK edge			2 × t _{HCLK} + 2 × t _{UCLK}	ns
t _{DSU}	Data input setup time before SCLOCK edge ²	1 × t _{UCLK}			ns
t _{DHD}	Data input hold time after SCLOCK edge ²	2 × t _{UCLK}			ns
t _{DF}	Data output fall time		5	12.5	ns
t _{DR}	Data output rise time		5	12.5	ns
t _{SR}	SCLOCK rise time		5	12.5	ns
t _{SF}	SCLOCK fall time		5	12.5	ns

¹ t_{HCLK} depends on the clock divider or CD bits in the PLLCON MMR, t_{HCLK} = t_{UCLK}/2^{CD}.

² t_{UCLK} = 23.9 ns. It corresponds to the 41.78 MHz internal clock from the PLL before the clock divider.



Figure 6. SPI Master Mode Timing (PHASE Mode = 1)

06020-004

ADuC7128/ADuC7129

Table 6. SPI Master Mode Timing (PHASE Mode = 0)

Parameter	Description	Min	Typ	Max	Unit
t_{SL}	SCLOCK low pulse width ¹		$(SPIDIV + 1) \times t_{HCLK}$		ns
t_{SH}	SCLOCK high pulse width ¹		$(SPIDIV + 1) \times t_{HCLK}$		ns
t_{DAV}	Data output valid after SCLOCK edge			$2 \times t_{HCLK} + 2 \times t_{UCLK}$	ns
t_{DOSU}	Data output setup before SCLOCK edge			75	ns
t_{DSU}	Data input setup time before SCLOCK edge ²	$1 \times t_{UCLK}$			ns
t_{DHD}	Data input hold time after SCLOCK edge ²	$2 \times t_{UCLK}$			ns
t_{DF}	Data output fall time		5	12.5	ns
t_{DR}	Data output rise time		5	12.5	ns
t_{SR}	SCLOCK rise time		5	12.5	ns
t_{SF}	SCLOCK fall time		5	12.5	ns

¹ t_{HCLK} depends on the clock divider or CD bits in the PLLCON MMR, $t_{HCLK} = t_{UCLK}/2^{CD}$.

² $t_{UCLK} = 23.9$ ns. It corresponds to the 41.78 MHz internal clock from the PLL before the clock divider.



Figure 7. SPI Master Mode Timing (PHASE Mode = 0)

06020-005

Table 7. SPI Slave Mode Timing (PHASE Mode = 1)

Parameter	Description	Min	Typ	Max	Unit
t _{CS}	CS to SCLOCK edge ¹	2 × t _{UCLK}			ns
t _{SL}	SCLOCK low pulse width ²		(SPIDIV + 1) × t _{HCLK}		ns
t _{SH}	SCLOCK high pulse width ²		(SPIDIV + 1) × t _{HCLK}		ns
t _{DAV}	Data output valid after SCLOCK edge			2 × t _{HCLK} + 2 × t _{UCLK}	ns
t _{DSU}	Data input setup time before SCLOCK edge ¹	1 × t _{UCLK}			ns
t _{DHD}	Data input hold time after SCLOCK edge ¹	2 × t _{UCLK}			ns
t _{DF}	Data output fall time		5	12.5	ns
t _{DR}	Data output rise time		5	12.5	ns
t _{SR}	SCLOCK rise time		5	12.5	ns
t _{SF}	SCLOCK fall time		5	12.5	ns
t _{SFS}	CS high after SCLOCK edge	0			ns

¹ t_{UCLK} = 23.9 ns. It corresponds to the 41.78 MHz internal clock from the PLL before the clock divider.

² t_{HCLK} depends on the clock divider or CD bits in the PLLCON MMR, t_{HCLK} = t_{UCLK}/2^{CD}.



Figure 8. SPI Slave Mode Timing (PHASE Mode = 1)

06020-006

ADuC7128/ADuC7129

Table 8. SPI Slave Mode Timing (PHASE Mode = 0)

Parameter	Description	Min	Typ	Max	Unit
t_{CS}	CS to SCLOCK edge ¹	$2 \times t_{UCLK}$			ns
t_{SL}	SCLOCK low pulse width ²		$(SPIDIV + 1) \times t_{HCLK}$		ns
t_{SH}	SCLOCK high pulse width ²		$(SPIDIV + 1) \times t_{HCLK}$		ns
t_{DAV}	Data output valid after SCLOCK edge			$2 \times t_{HCLK} + 2 \times t_{UCLK}$	ns
t_{DSU}	Data input setup time before SCLOCK edge ¹	$1 \times t_{UCLK}$			ns
t_{DHD}	Data input hold time after SCLOCK edge ¹	$2 \times t_{UCLK}$			ns
t_{DF}	Data output fall time		5	12.5	ns
t_{DR}	Data output rise time		5	12.5	ns
t_{SR}	SCLOCK rise time		5	12.5	ns
t_{SF}	SCLOCK fall time		5	12.5	ns
t_{DOCS}	Data output valid after CS edge			25	ns
t_{SFS}	CS high after SCLOCK edge	0			ns

¹ $t_{UCLK} = 23.9$ ns. It corresponds to the 41.78 MHz internal clock from the PLL before the clock divider.

² t_{HCLK} depends on the clock divider or CD bits in the PLLCON MMR, $t_{HCLK} = t_{UCLK}/2^{CD}$.

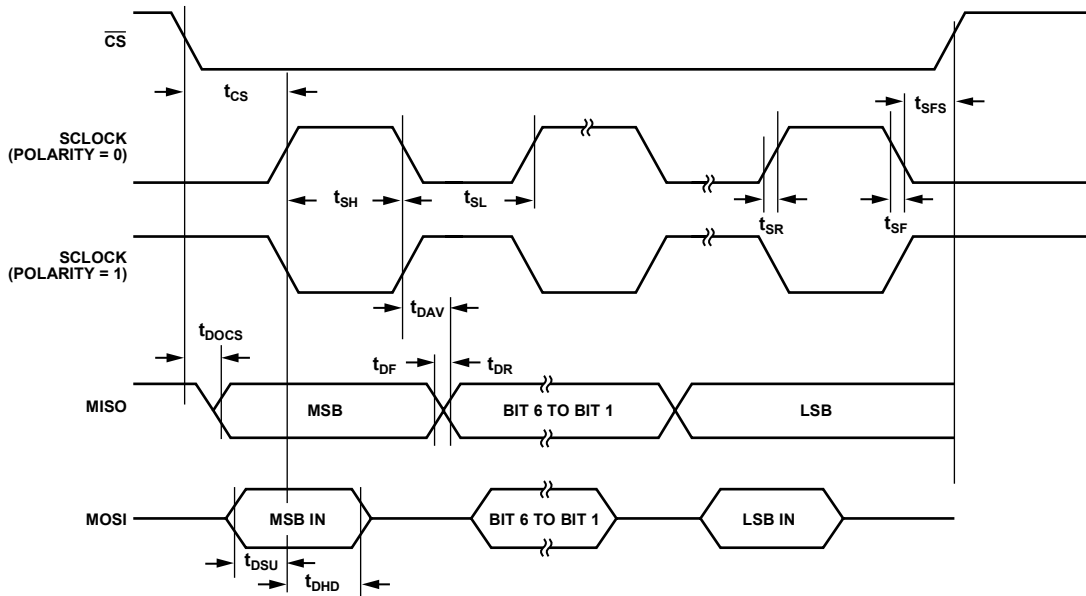

Figure 9. SPI Slave Mode Timing (PHASE Mode = 0)

06020-007

ABSOLUTE MAXIMUM RATINGS

$DV_{DD} = IOV_{DD}$, $AGND = REFGND = DACGND = GND_{REF}$.

$T_A = 25^\circ\text{C}$, unless otherwise noted.

Table 9.

Parameter	Rating
AV_{DD} to DV_{DD}	-0.3 V to +0.3 V
AGND to DGND	-0.3 V to +0.3 V
IOV_{DD} to IOGND, AV_{DD} to AGND	-0.3 V to +6 V
Digital Input Voltage to IOGND	-0.3 V to $IOV_{DD} + 0.3$ V
Digital Output Voltage to IOGND	-0.3 V to $IOV_{DD} + 0.3$ V
V_{REF} to AGND	-0.3 V to $AV_{DD} + 0.3$ V
Analog Inputs to AGND	-0.3 V to $AV_{DD} + 0.3$ V
Analog Output to AGND	-0.3 V to $AV_{DD} + 0.3$ V
Operating Temperature Range	
Industrial	-40°C to +125°C
Storage Temperature Range	-65°C to +150°C
Junction Temperature	150°C
θ_{JA} Thermal Impedance	
64-Lead LFCSP	24°C/W
64-Lead LQFP	47°C/W
80-Lead LQFP	38°C/W
Peak Solder Reflow Temperature	
SnPb Assemblies (10 sec to 30 sec)	240°C
RoHS Compliant Assemblies (20 sec to 40 sec)	260°C

Stresses above those listed under Absolute Maximum Ratings may cause permanent damage to the device. This is a stress rating only; functional operation of the device at these or any other conditions above those indicated in the operational section of this specification is not implied. Exposure to absolute maximum rating conditions for extended periods may affect device reliability.

Only one absolute maximum rating can be applied at any one time.

ESD CAUTION



ESD (electrostatic discharge) sensitive device. Charged devices and circuit boards can discharge without detection. Although this product features patented or proprietary protection circuitry, damage may occur on devices subjected to high energy ESD. Therefore, proper ESD precautions should be taken to avoid performance degradation or loss of functionality.

PIN CONFIGURATION AND FUNCTION DESCRIPTIONS

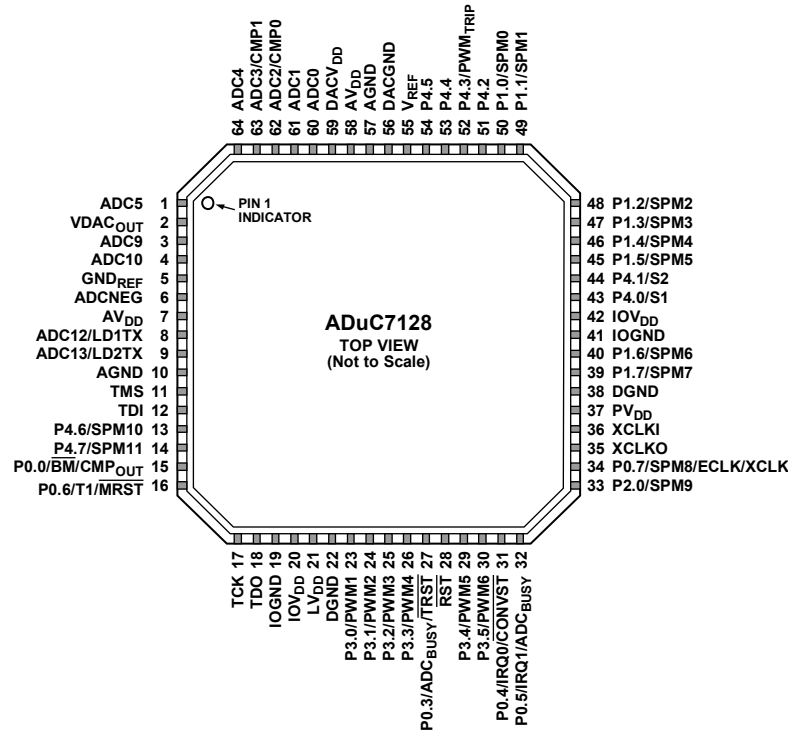

Figure 10. ADuC7128 Pin Configuration

Table 10. ADuC7128 Pin Function Descriptions

Pin No.	Mnemonic	Type ¹	Description
1	ADC5	I	Single-Ended or Differential Analog Input 5/Line Driver Input.
2	VDAC _{OUT}	O	Output from DAC Buffer.
3	ADC9	I	Single-Ended or Differential Analog Input 9.
4	ADC10	I	Single-Ended or Differential Analog Input 10.
5	GND _{REF}	S	Ground Voltage Reference for the ADC. For optimal performance, the analog power supply should be separated from IOGND and DGND.
6	ADCNEG	I	Bias Point or Negative Analog Input of the ADC in Pseudo Differential Mode. Must be connected to the ground of the signal to convert. This bias point must be between 0 V and 1 V.
7, 58	AV _{DD}	S	Analog Power.
8	ADC12/LD1TX	I/O	Single-Ended or Differential Analog Input 12/DAC Differential Negative Output.
9	ADC13/LD2TX	I/O	Single-Ended or Differential Analog Input 13/DAC Differential Positive Output.
10, 57	AGND	S	Analog Ground. Ground reference point for the analog circuitry.
11	TMS	I	JTAG Test Port Input, Test Mode Select. Debug and download access.
12	TDI	I	JTAG Test Port Input, Test Data In. Debug and download access.
13	P4.6/SPM10	I/O	General-Purpose Input and Output Port 4.6/Serial Port Mux Pin 10.
14	P4.7/SPM11	I/O	General-Purpose Input and Output Port 4.7/Serial Port Mux Pin 11.
15	P0.0/BM/CMP _{OUT}	I/O	General-Purpose Input and Output Port 0.0/Boot Mode. The ADuC7128 enters download mode if BM is low at reset and executes code if BM is pulled high at reset through a 1 kΩ resistor/voltage comparator output.
16	P0.6/T1/MRST	O	General-Purpose Output Port 0.6/Timer1 Input/Power-On Reset Output.
17	TCK	I	JTAG Test Port Input, Test Clock. Debug and download access.
18	TDO	O	JTAG Test Port Output, Test Data Out. Debug and download access.
19, 41	IOGND	S	Ground for GPIO. Typically connected to DGND.
20, 42	IOV _{DD}	S	3.3 V Supply for GPIO and Input of the On-Chip Voltage Regulator.

Pin No.	Mnemonic	Type ¹	Description
21	LV _{DD}	S	2.5 V Output of the On-Chip Voltage Regulator. Must be connected to a 0.47 μ F capacitor to DGND.
22	DGND	S	Ground for Core Logic.
23	P3.0/PWM1	I/O	General-Purpose Input and Output Port 3.0/PWM1 Output.
24	P3.1/PWM2	I/O	General-Purpose Input and Output Port 3.1/PWM2 Output.
25	P3.2/PWM3	I/O	General-Purpose Input and Output Port 3.2/PWM3 Output.
26	P3.3/PWM4	I/O	General-Purpose Input and Output Port 3.3/PWM4 Output.
27	P0.3/ADC _{BUSY} / $\overline{\text{TRST}}$	I/O	General-Purpose Input and Output Port 3.3/ADC _{BUSY} Signal/JTAG Test Port Input, Test Reset. Debug and download access.
28	$\overline{\text{RST}}$	I	Reset Input (Active Low).
29	P3.4/PWM5	I/O	General-Purpose Input and Output Port 3.4/PWM5 Output.
30	P3.5/PWM6	I/O	General-Purpose Input and Output Port 3.5/PWM6 Output.
31	P0.4/IRQ0/ $\overline{\text{CONVST}}$	I/O	General-Purpose Input and Output Port 0.5/External Interrupt Request 0, Active High/Start Conversion Input Signal for ADC.
32	P0.5/IRQ1/ADC _{BUSY}	I/O	General-Purpose Input and Output Port 0.6/External Interrupt Request 1, Active High/ADC _{BUSY} Signal.
33	P2.0/SPM9	I/O	General-Purpose Input and Output Port 2.0/Serial Port Mux Pin 9.
34	P0.7/SPM8/ECLK/XCLK	I/O	General-Purpose Input and Output Port 0.7/Serial Port Mux Pin 8/Output for the External Clock Signal/Input to the Internal Clock Generator Circuits.
35	XCLKO	O	Output from the Crystal Oscillator Inverter.
36	XCLKI	I	Input to the Crystal Oscillator Inverter and Input to the Internal Clock Generator Circuits.
37	PV _{DD}	S	2.5 V PLL Supply. Must be connected to a 0.1 μ F capacitor to DGND. Should be connected to 2.5 V LDO output.
38	DGND	S	Ground for PLL.
39	P1.7/SPM7	I/O	General-Purpose Input and Output Port 1.7/Serial Port Mux Pin 7.
40	P1.6/SPM6	I/O	General-Purpose Input and Output Port 1.6/Serial Port Mux Pin 6.
43	P4.0/S1	I/O	General-Purpose Input and Output Port 4.0/Quadrature Input 1.
44	P4.1/S2	I/O	General-Purpose Input and Output Port 4.1/Quadrature Input 2.
45	P1.5/SPM5	I/O	General-Purpose Input and Output Port 1.5/Serial Port Mux Pin 5.
46	P1.4/SPM4	I/O	General-Purpose Input and Output Port 1.4/Serial Port Mux Pin 4.
47	P1.3/SPM3	I/O	General-Purpose Input and Output Port 1.3/Serial Port Mux Pin 3.
48	P1.2/SPM2	I/O	General-Purpose Input and Output Port 1.2/Serial Port Mux Pin 2.
49	P1.1/SPM1	I/O	General-Purpose Input and Output Port 1.1/Serial Port Mux Pin 1.
50	P1.0/SPM0	I/O	General-Purpose Input and Output Port 1.0/Serial Port Mux Pin 0.
51	P4.2	I/O	General-Purpose Input and Output Port 4.2.
52	P4.3/ PWM _{TRIP}	I/O	General-Purpose Input and Output Port 4.3/PWM Safety Cutoff.
53	P4.4	I/O	General-Purpose Input and Output Port 4.4.
54	P4.5	I/O	General-Purpose Input and Output Port 4.5.
55	V _{REF}	I/O	2.5 V Internal Voltage Reference. Must be connected to a 0.47 μ F capacitor when using the internal reference.
56	DACGND	S	Ground for the DAC. Typically connected to AGND.
59	DACV _{DD}	S	Power Supply for the DAC. This must be supplied with 2.5 V. This can be connected to the LDO output.
60	ADC0	I	Single-Ended or Differential Analog Input 0.
61	ADC1	I	Single-Ended or Differential Analog Input 1.
62	ADC2/CMP0	I	Single-Ended or Differential Analog Input 2/Comparator Positive Input.
63	ADC3/CMP1	I	Single-Ended or Differential Analog Input 3/Comparator Negative Input.
64	ADC4	I	Single-Ended or Differential Analog Input 4.

¹ I = input, O = output, S = supply.

ADuC7128/ADuC7129



Figure 11. ADuC7129 Pin Configuration

Table 11. ADuC7129 Pin Function Descriptions

Pin No.	Mnemonic	Type ¹	Description
1	ADC4	I	Single-Ended or Differential Analog Input 4.
2	ADC5	I	Single-Ended or Differential Analog Input 5.
3	ADC6	I	Single-Ended or Differential Analog Input 6.
4	ADC7	I	Single-Ended or Differential Analog Input 7.
5	VDAC _{OUT} /ADC8	I	Output from DAC Buffer/Single-Ended or Differential Analog Input 8.
6	ADC9	I	Single-Ended or Differential Analog Input 9.
7	ADC10	I	Single-Ended or Differential Analog Input 10.
8	GND _{REF}	S	Ground Voltage Reference for the ADC. For optimal performance, the analog power supply should be separated from IOGND and DGND.
9	ADCNEG	I	Bias Point or Negative Analog Input of the ADC in Pseudo Differential Mode. Must be connected to the ground of the signal to convert. This bias point must be between 0 V and 1 V.
10, 73, 74	AV _{DD}	S	3.3 V Analog Supply.
11	ADC12/LD1TX	I/O	Single-Ended or Differential Analog Input 12/DAC Differential Negative Output.
12	ADC13/LD2TX	I/O	Single-Ended or Differential Analog Input 13/DAC Differential Positive Output.
13	AGND	S	Analog Ground. Ground reference point for the analog circuitry.
14	TMS	I	JTAG Test Port Input, Test Mode Select. Debug and download access.
15	TDI/P0.1/ $\overline{\text{BLE}}$	I/O	JTAG Test Port Input, Test Data In. Debug and download access/general-purpose input and output Port 0.1/External Memory BLE.
16	P2.3/AE	I/O	General-Purpose Input and Output Port 2.3/AE Output.

Pin No.	Mnemonic	Type ¹	Description
17	P4.6/SPM10/AD14	I/O	General-Purpose Input and Output Port 4.6/Serial Port Mux Pin 10/External Memory AD14.
18	P4.7/SPM11/AD15	I/O	General-Purpose Input and Output Port 4.7/Serial Port Mux Pin 11/External Memory AD15.
19	P0.0/ \overline{BM} /CMP _{OUT} /MS0	I/O	General-Purpose Input and Output Port 0.0 /Boot Mode. The ADuC7129 enters download mode if \overline{BM} is low at reset and executes code if \overline{BM} is pulled high at reset through a 1 k Ω resistor/voltage comparator output/external memory MS0.
20	P0.6/T1/ \overline{MRST}	O	General-Purpose Output Port 0.6/Timer1 Input/Power-On Reset Output/External Memory AE.
21	TCK	I	JTAG Test Port Input, Test Clock. Debug and download access.
22	TDO/P0.2/ \overline{BHE}	O	JTAG Test Port Output, Test Data Out. Debug and download access/general-purpose input and output Port 0.2/External Memory \overline{BHE} .
23, 53, 67	IOGND	S	Ground for GPIO. Typically connected to DGND.
24, 54	IOV _{DD}	S	3.3 V Supply for GPIO and Input of the On-Chip Voltage Regulator.
25	LV _{DD}	S	2.5 V Output of the On-Chip Voltage Regulator. Must be connected to a 0.47 μ F capacitor to DGND.
26	DGND	S	Ground for Core Logic.
27	P3.0/PWM1/AD0	I/O	General-Purpose Input and Output Port 3.0/PWM1 Output/External Memory AD0.
28	P3.1/PWM2/AD1	I/O	General-Purpose Input and Output Port 3.1/PWM2 Output/External Memory AD1.
29	P3.2/PWM3/AD2	I/O	General-Purpose Input and Output Port 3.2/PWM3 Output/External Memory AD2.
30	P3.3/PWM4/AD3	I/O	General-Purpose Input and Output Port 3.3/PWM4 Output//External Memory AD3.
31	P2.4/MS0	I/O	General-Purpose Input and Output Port 2.4/Memory Select 0.
32	P0.3/ADC _{BUSY} / \overline{TRST} /A16	I/O	General-Purpose Input and Output Port 3.3/ADC _{BUSY} Signal/JTAG Test Port Input, Test Reset. Debug and download access/External Memory A16.
33	P2.5/MS1	I/O	General-Purpose Input and Output Port 2.5/Memory Select 1.
34	P2.6/MS2	I/O	General-Purpose Input and Output Port 2.6/Memory Select 2.
35	\overline{RST}	I	Reset Input (Active Low).
36	P3.4/PWM5/AD4	I/O	General-Purpose Input and Output Port 3.4/PWM5 Output/External Memory AD4.
37	P3.5/PWM6/AD5	I/O	General-Purpose Input and Output Port 3.5/PWM6 Output/External Memory AD5.
38	P0.4/IRQ0/ \overline{CONVST} /MS1	I/O	General-Purpose Input and Output Port 0.5/External Interrupt Request 0, Active High/Start Conversion Input Signal for ADC/External Memory MS1.
39	P0.5/IRQ1/ADC _{BUSY}	I/O	General-Purpose Input and Output Port 0.6/External Interrupt Request 1, Active High/ADC _{BUSY} Signal.
40	P2.0/SPM9	I/O	General-Purpose Input and Output Port 2.0/Serial Port Mux Pin 9.
41	P0.7/SPM8/ECLK/XCLK	I/O	General-Purpose Input and Output Port 0.7/Serial Port Mux Pin 8/Output for the External Clock Signal/Input to the Internal Clock Generator Circuits.
42	XCLKO	O	Output from the Crystal Oscillator Inverter.
43	XCLKI	I	Input to the Crystal Oscillator Inverter and Input to the Internal Clock Generator Circuits.
44	PV _{DD}	S	2.5 V PLL Supply. Must be connected to a 0.1 μ F capacitor to DGND. Should be connected to 2.5 V LDO output.
45	DGND	S	Ground for PLL.
46	P3.6/AD6	I/O	General-Purpose Input and Output Port 3.6/External Memory AD6.
47	P3.7/AD7	I/O	General-Purpose Input and Output Port 3.7/External Memory AD7.
48	P2.7/MS3	I/O	General-Purpose Input and Output Port 2.7/Memory Select 3.
49	P2.1/ \overline{WS}	I/O	General-Purpose Input and Output Port 2.1/Memory Write Select.
50	P2.2/ \overline{RS}	I/O	General-Purpose Input and Output Port 2.1/Memory Read Select.
51	P1.7/SPM7	I/O	General-Purpose Input and Output Port 1.7/Serial Port Mux Pin 7.
52	P1.6/SPM6	I/O	General-Purpose Input and Output Port 1.6/Serial Port Mux Pin 6.
55	P4.0/S1/AD8	I/O	General-Purpose Input and Output Port 4.0/Quadrature Input 1/External Memory AD8.
56	P4.1/S2/AD9	I/O	General-Purpose Input and Output Port 4.1/Quadrature Input 2/External Memory AD9.
57	P1.5/SPM5	I/O	General-Purpose Input and Output Port 1.5/Serial Port Mux Pin 5.
58	P1.4/SPM4	I/O	General-Purpose Input and Output Port 1.4/Serial Port Mux Pin 4.
59	P1.3/SPM3	I/O	General-Purpose Input and Output Port 1.3/Serial Port Mux Pin 3.
60	P1.2/SPM2	I/O	General-Purpose Input and Output Port 1.2/Serial Port Mux Pin 2.
61	P1.1/SPM1	I/O	General-Purpose Input and Output Port 1.1/Serial Port Mux Pin 1.
62	P1.0/SPM0	I/O	General-Purpose Input and Output Port 1.0/Serial Port Mux Pin 0.

ADuC7128/ADuC7129

Pin No.	Mnemonic	Type ¹	Description
63	P4.2/AD10	I/O	General-Purpose Input and Output Port 4.2/External Memory AD10.
64	P4.3/PWM _{TRIP} /AD11	I/O	General-Purpose Input and Output Port 4.3/PWM Safety Cutoff/External Memory AD11.
65	P4.4/AD12	I/O	General-Purpose Input and Output Port 4.4/External Memory AD12.
66	P4.5/AD13	I/O	General-Purpose Input and Output Port 4.5/External Memory AD13.
68	REFGND	S	Ground for V _{REF} . Typically connected to DGND.
69	V _{REF}	I/O	2.5 V Internal Voltage Reference. Must be connected to a 0.47 μF capacitor when using the internal reference.
70	DACGND	S	Ground for the DAC. Typically connected to AGND.
71, 72	AGND	S	Analog Ground.
75	DACV _{DD}	S	Power Supply for the DAC. This must be supplied with 2.5 V. It can be connected to the LDO output.
76	ADC11	I	Single-Ended or Differential Analog Input 11.
77	ADC0	I	Single-Ended or Differential Analog Input 0.
78	ADC1	I	Single-Ended or Differential Analog Input 1.
79	ADC2/CMP0	I	Single-Ended or Differential Analog Input 2/Comparator Positive Input.
80	ADC3/CMP1	I	Single-Ended or Differential Analog Input 3/Comparator Negative Input.

¹ I = input, O = output, S = supply.

TYPICAL PERFORMANCE CHARACTERISTICS

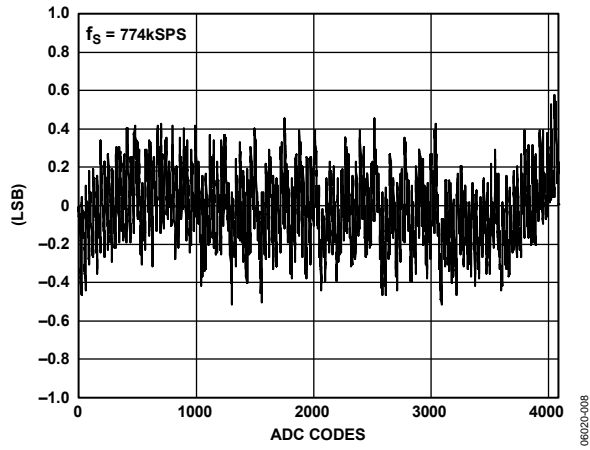

Figure 12. Typical INL Error, $f_s = 774$ kSPS



Figure 15. Typical DNL Error, $f_s = 774$ kSPS

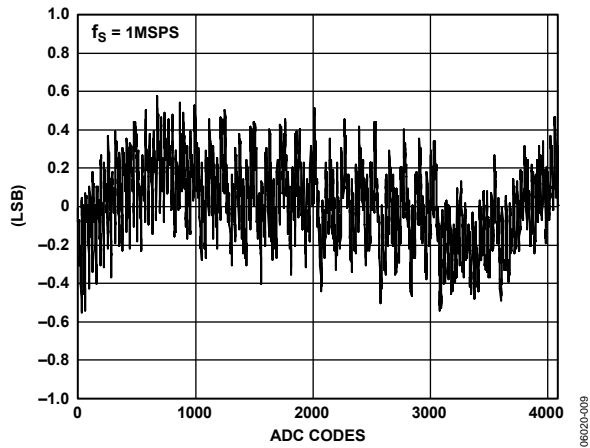

Figure 13. Typical INL Error, $f_s = 1$ MSPS



Figure 16. Typical DNL Error, $f_s = 1$ MSPS

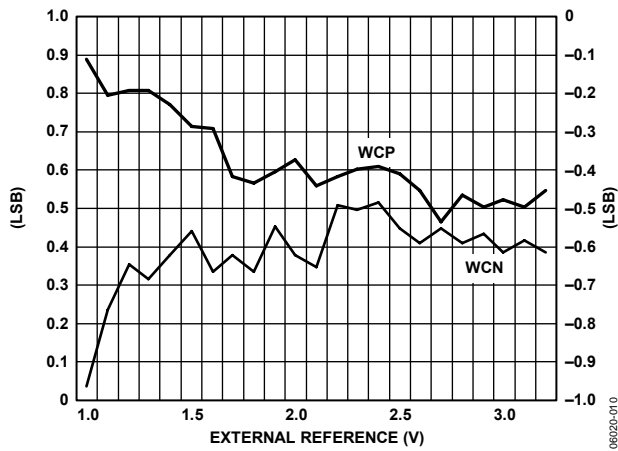

Figure 14. Typical Worst Case INL Error vs. V_{REF} , $f_s = 774$ kSPS



Figure 17. Typical Worst Case DNL Error vs. V_{REF} , $f_s = 774$ kSPS



Figure 18. Code Histogram Plot

06020-014



Figure 21. Typical Dynamic Performance vs. V_{REF}

06020-017



Figure 19. Dynamic Performance, $f_s = 774\text{ kSPS}$

06020-015

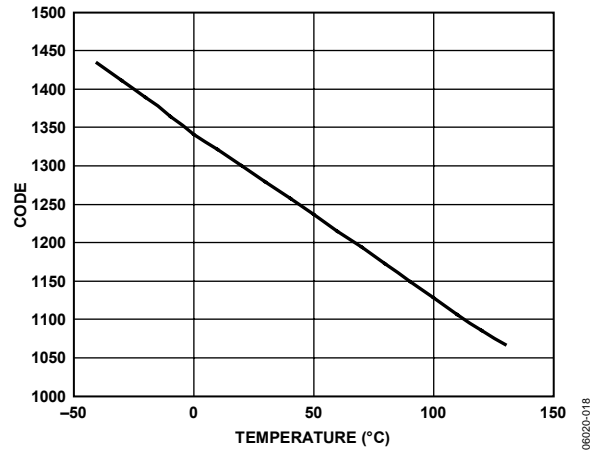

Figure 22. On-Chip Temperature Sensor Voltage Output vs. Temperature

06020-018



Figure 20. Dynamic Performance, $f_s = 1\text{ MSPS}$

06020-016

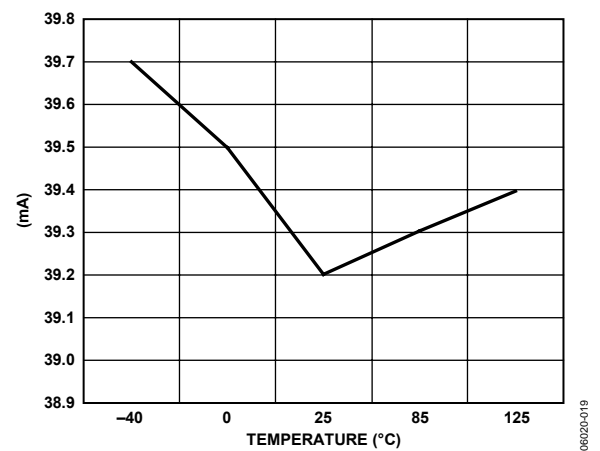

Figure 23. Current Consumption vs. Temperature @ $CD = 0$

06020-019



Figure 24. Current Consumption vs. Temperature @ CD = 3



Figure 26. Current Consumption vs. Temperature in Sleep Mode



Figure 25. Current Consumption vs. Temperature @ CD = 7



Figure 27. Current Consumption vs. ADC Speed

TERMINOLOGY

ADC SPECIFICATIONS

Integral Nonlinearity

The maximum deviation of any code from a straight line passing through the endpoints of the ADC transfer function. The endpoints of the transfer function are zero scale, a point $\frac{1}{2}$ LSB below the first code transition and full scale, a point $\frac{1}{2}$ LSB above the last code transition.

Differential Nonlinearity

The difference between the measured and the ideal 1 LSB change between any two adjacent codes in the ADC.

Offset Error

The deviation of the first code transition (0000 . . . 000) to (0000 . . . 001) from the ideal, that is, $\pm\frac{1}{2}$ LSB.

Gain Error

The deviation of the last code transition from the ideal AIN voltage (full scale – 1.5 LSB) after the offset error has been adjusted out.

Signal to (Noise + Distortion) Ratio

The measured ratio of signal to (noise + distortion) at the output of the ADC. The signal is the rms amplitude of the fundamental. Noise is the rms sum of all nonfundamental signals up to half the sampling frequency ($f_s/2$), excluding dc. The ratio is dependent on the number of quantization levels in the digitization process; the more levels, the smaller the quantization noise.

The theoretical signal to (noise + distortion) ratio for an ideal N-bit converter with a sine wave input is given by

$$\text{Signal to (Noise + Distortion)} = (6.02 N + 1.76) \text{ dB}$$

Thus, for a 12-bit converter, this is 74 dB.

Total Harmonic Distortion

The ratio of the rms sum of the harmonics to the fundamental.

DAC SPECIFICATIONS

Relative Accuracy

Otherwise known as endpoint linearity, relative accuracy is a measure of the maximum deviation from a straight line passing through the endpoints of the DAC transfer function. It is measured after adjusting for zero error and full-scale error.

Voltage Output Settling Time

The amount of time it takes for the output to settle to within a 1 LSB level for a full-scale input change.

OVERVIEW OF THE ARM7TDMI CORE

The ARM7 core is a 32-bit reduced instruction set computer (RISC). It uses a single 32-bit bus for instruction and data. The length of the data can be 8 bits, 16 bits, or 32 bits. The length of the instruction word is 32 bits.

The ARM7TDMI is an ARM7 core with the following four additional features:

- T, support for the Thumb® (16-bit) instruction set
- D, support for debug
- M, support for long multiplications
- I, includes the embedded ICE module to support embedded system debugging

THUMB MODE (T)

An ARM® instruction is 32-bits long. The ARM7TDMI processor supports a second instruction set that has been compressed into 16-bits, called the Thumb instruction set. Faster execution from 16-bit memory and greater code density can usually be achieved by using the Thumb instruction set instead of the ARM instruction set, which makes the ARM7TDMI core particularly suitable for embedded applications.

However, the Thumb mode has two limitations:

- Thumb code typically requires more instructions for the same job. As a result, ARM code is usually best for maximizing the performance of the time-critical code.
- The Thumb instruction set does not include some of the instructions needed for exception handling, which automatically switches the core to ARM code for exception handling.

See the ARM7TDMI user guide for details on the core architecture, the programming model, and both the ARM and Thumb instruction sets.

LONG MULTIPLY (M)

The ARM7TDMI instruction set includes four extra instructions that perform 32-bit by 32-bit multiplication with 64-bit result, and 32-bit by 32-bit multiplication-accumulation (MAC) with 64-bit result. This result is achieved in fewer cycles than required on a standard ARM7 core.

EMBEDDEDICE (I)

EmbeddedICE provides integrated on-chip support for the core. The EmbeddedICE module contains the breakpoint and watchpoint registers that allow code to be halted for debugging purposes. These registers are controlled through the JTAG test port.

When a breakpoint or watchpoint is encountered, the processor halts and enters debug state. Once in a debug state, the processor registers can be inspected, as well as the Flash/EE, the SRAM, and the memory mapped registers.

EXCEPTIONS

ARM supports five types of exceptions and a privileged processing mode for each type. The five types of exceptions are

- Normal interrupt or IRQ. This is provided to service general-purpose interrupt handling of internal and external events.
- Fast interrupt or FIQ. This is provided to service data transfer or communication channel with low latency. FIQ has priority over IRQ.
- Memory abort.
- Attempted execution of an undefined instruction.
- Software interrupt instruction (SWI). This can be used to make a call to an operating system.

Typically, the programmer defines interrupt as IRQ, but for higher priority interrupt, that is, faster response time, the programmer can define interrupt as FIQ.

ARM REGISTERS

ARM7TDMI has a total of 37 registers: 31 general-purpose registers and six status registers. Each operating mode has dedicated banked registers.

When writing user-level programs, 15 general-purpose, 32-bit registers (R0 to R14), the program counter (R15), and the current program status register (CPSR) are usable. The remaining registers are used only for system-level programming and exception handling.

When an exception occurs, some of the standard registers are replaced with registers specific to the exception mode. All exception modes have replacement banked registers for the stack pointer (R13) and the link register (R14), as represented in Figure 28. The fast interrupt mode has more registers (R8 to R12) for fast interrupt processing. Interrupt processing can begin without the need to save or restore these registers and, thus, saves critical time in the interrupt handling process.

More information relative to the programmer's model and the ARM7TDMI core architecture can be found in the following ARM7TDMI technical and ARM architecture manuals available directly from ARM Ltd.:

- DDI0029G, *ARM7TDMI Technical Reference Manual*
- DDI-0100, *ARM Architecture Reference Manual*

ADuC7128/ADuC7129



Figure 28. Register Organization

INTERRUPT LATENCY

The worst case latency for an FIQ consists of the following:

- The longest time the request can take to pass through the synchronizer
- The time for the longest instruction to complete (the longest instruction is an LDM) that loads all the registers, including the PC
- The time for the data abort entry
- The time for FIQ entry

At the end of this time, the ARM7TDMI executes the instruction at Address 0x1C (FIQ interrupt vector address). The maximum total time is 50 processor cycles, which is just under 1.2 μ s in a system using a continuous 41.78 MHz processor clock.

The maximum IRQ latency calculation is similar, but it must allow for the fact that FIQ has higher priority and could delay entry into the IRQ handling routine for an arbitrary length of time. This time can be reduced to 42 cycles if the LDM command is not used; some compilers have an option to compile without using this command. Another option is to run the part in Thumb mode, where the time is reduced to 22 cycles.

The minimum latency for FIQ or IRQ interrupts is five cycles. It consists of the shortest time the request can take through the synchronizer plus the time to enter the exception mode.

Note that the ARM7TDMI always runs in ARM (32-bit) mode when in privileged modes, that is, when executing interrupt service routines.

MEMORY ORGANIZATION

The ADuC7128/ADuC7129 incorporate three separate blocks of memory: 8 kB of SRAM and two 64 kB of on-chip Flash/EE memory. There are 126 kB of on-chip Flash/EE memory available to the user, and the remaining 2 kB are reserved for the factory-configured boot page. These two blocks are mapped as shown in Figure 29.

Note that by default, after a reset, the Flash/EE memory is mirrored at Address 0x00000000. It is possible to remap the SRAM at Address 0x00000000 by clearing Bit 0 of the REMAP MMR. This remap function is described in more detail in the Flash/EE Memory section.



Figure 29. Physical Memory Map

MEMORY ACCESS

The ARM7 core sees memory as a linear array of 2^{32} byte locations where the different blocks of memory are mapped as outlined in Figure 29.

The ADuC7128/ADuC7129 memory organization is configured in little endian format: the least significant byte is located in the lowest byte address and the most significant byte in the highest byte address.

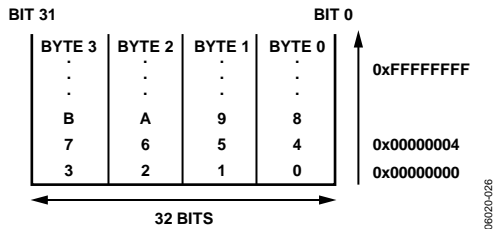

Figure 30. Little Endian Format

FLASH/EE MEMORY

The 128 kB of Flash/EE is organized as two banks of $32\text{ k} \times 16$ bits. In the first block, $31\text{ k} \times 16$ bits are user space and $1\text{ k} \times 16$ bits is reserved for the factory-configured boot page. The page size of this Flash/EE memory is 512 bytes.

The second 64 kB block is organized in a similar manner. It is arranged in $32\text{ k} \times 16$ bits. All of this is available as user space.

The 126 kB of Flash/EE is available to the user as code and nonvolatile data memory. There is no distinction between data and program as ARM code shares the same space. The real width of the Flash/EE memory is 16 bits, meaning that in ARM mode (32-bit instruction), two accesses to the Flash/EE are necessary for each instruction fetch. Therefore, it is recommended that Thumb mode be used when executing from Flash/EE memory for optimum access speed. The maximum access speed for the Flash/EE memory is 41.78 MHz in Thumb mode and 20.89 MHz in full ARM mode (see the Execution Time from SRAM and FLASH/EE section).

SRAM

The 8 kB of SRAM are available to the user, organized as $2\text{ k} \times 32$ bits, that is, 2 k words. ARM code can run directly from SRAM at 41.78 MHz, given that the SRAM array is configured as a 32-bit wide memory array (see the Execution Time from SRAM and FLASH/EE section).

MEMORY MAPPED REGISTERS

The memory mapped register (MMR) space is mapped into the upper two pages of the memory array and accessed by indirect addressing through the ARM7 banked registers.

The MMR space provides an interface between the CPU and all on-chip peripherals. All registers except the core registers reside in the MMR area. All shaded locations shown in Figure 31 are unoccupied or reserved locations and should not be accessed by user software. See Table 12 through Table 31 for a full MMR memory map.

The access time reading or writing a MMR depends on the advanced microcontroller bus architecture (AMBA) bus used to access the peripheral. The processor has two AMBA buses: advanced high performance bus (AHB) used for system modules, and advanced peripheral bus (APB) used for lower performance peripherals. Access to the AHB is one cycle, and access to the APB is two cycles. All peripherals on the ADuC7128/ADuC7129 are on the APB except the Flash/EE memory and the GPIOs.

ADuC7128/ADuC7129



Figure 31. Memory Mapped Registers

COMPLETE MMR LISTING

Note that the Access Type column corresponds to the access time reading or writing an MMR. It depends on the AMBA bus used to access the peripheral. The processor has two AMBA buses: the AHB (advanced high performance bus) used for system modules and the APB (advanced peripheral bus) used for lower performance peripherals.

Table 12. IRQ Base Address = 0xFFFF0000

Address	Name	Byte	Access Type	Cycle
0x0000	IRQSTA	4	R	1
0x0004	IRQSIG	4	R	1
0x0008	IRQEN	4	R/W	1
0x000C	IRQCLR	4	W	1
0x0010	SWICFG	4	W	1
0x0100	FIQSTA	4	R	1
0x0104	FIQSIG	4	R	1
0x0108	FIQEN	4	R/W	1
0x010C	FIQCLR	4	W	1

Table 13. System Control Base Address = 0xFFFF0200

Address	Name	Byte	Access Type	Cycle
0x0220	REMAP	1	R/W	1
0x0230	RSTSTA	1	R	1
0x0234	RSTCLR	1	W	1

Table 14. Timer Base Address = 0xFFFF0300

Address	Name	Byte	Access Type	Cycle
0x0300	T0LD	2	R/W	2
0x0304	T0VAL0	2	R	2
0x0308	T0VAL1	4	R	2
0x030C	T0CON	4	R/W	2
0x0310	T0ICLR	1	W	2
0x0314	T0CAP	2	R	2
0x0320	T1LD	4	R/W	2
0x0324	T1VAL	4	R	2
0x0328	T1CON	4	R/W	2
0x032C	T1ICLR	1	W	2
0x0330	T1CAP	4	R	2
0x0340	T2LD	4	R/W	2
0x0344	T2VAL	4	R	2
0x0348	T2CON	4	R/W	2
0x034C	T2ICLR	1	W	2
0x0360	T3LD	2	R/W	2
0x0364	T3VAL	2	R	2
0x0368	T3CON	2	R/W	2
0x036C	T3ICLR	1	W	2
0x0380	T4LD	4	R/W	2
0x0384	T4VAL	4	R	2
0x0388	T4CON	4	R/W	2
0x038C	T4ICLR	1	W	2
0x0390	T4CAP	4	R	2

Table 15. PLL Base Address = 0xFFFF0400

Address	Name	Byte	Access Type	Cycle
0x0404	POWKEY1	2	W	2
0x0408	POWCON	2	R/W	2
0x040C	POWKEY2	2	W	2
0x0410	PLLKEY1	2	W	2
0x0414	PLLCON	2	R/W	2
0x0418	PLLKEY2	2	W	2

Table 16. PSM Base Address = 0xFFFF0440

Address	Name	Byte	Access Type	Cycle
0x0444	PSMCON	2	R/W	2
0x0444	CMPCON	2	R/W	2

Table 17. Reference Base Address = 0xFFFF0480

Address	Name	Byte	Access Type	Cycle
0x048C	REFCON	1	R/W	2

Table 18. ADC Base Address = 0xFFFF0500

Address	Name	Byte	Access Type	Cycle
0x0500	ADCCON	2	R/W	2
0x0504	ADCCP	1	R/W	2
0x0508	ADCCN	1	R/W	2
0x050C	ADCSTA	1	R	2
0x0510	ADCDAT	4	R	2
0x0514	ADCRST	1	W	2

Table 19. DAC and DDS Base Address = 0xFFFF0670

Address	Name	Byte	Access Type	Cycle
0x0670	DACCON	2	R/W	2
0x0690	DDSCON	1	R/W	2
0x0694	DDSEFRQ	4	R/W	2
0x0698	DDSPHS	2	R/W	2
0x06A4	DACKEY0	1	R/W	2
0x06B4	DACDAT	2	R/W	2
0x06B8	DACEN	1	R/W	2
0x06BC	DACKEY1	1	R/W	2

Table 20. UART0 Base Address = 0xFFFF0700

Address	Name	Byte	Access Type	Cycle
0x0700	COM0TX	1	R/W	2
	COM0RX	1	R	2
	COM0DIV0	1	R/W	2
0x0704	COM0IEN0	1	R/W	2
	COM0DIV1	1	R/W	2
0x0708	COM0IID0	1	R	2
0x070C	COM0CON0	1	R/W	2
0x0710	COM0CON1	1	R/W	2
0x0714	COM0STA0	1	R	2
0x0718	COM0STA1	1	R	2
0x071C	COM0SCR	1	R/W	2
0x0720	COM0IEN1	1	R/W	2
0x0724	COM0IID1	1	R	2
0x0728	COM0ADR	1	R/W	2
0x072C	COM0DIV2	2	R/W	2

Table 21. UART1 Base Address = 0xFFFF0740

Address	Name	Byte	Access Type	Cycle
0x0740	COM1TX	1	R/W	2
	COM1RX	1	R	2
	COM1DIV0	1	R/W	2
0x0744	COM1IEN0	1	R/W	2
	COM1DIV1	1	R/W	2
0x0748	COM1IID0	1	R	2
0x074C	COM1CON0	1	R/W	2
0x0750	COM1CON1	1	R/W	2
0x0754	COM1STA0	1	R	2
0x0758	COM1STA1	1	R	2
0x075C	COM1SCR	1	R/W	2
0x0760	COM1IEN1	1	R/W	2
0x0764	COM1IID1	1	R	2
0x0768	COM1ADR	1	R/W	2
0x076C	COM1DIV2	2	R/W	2

Table 22. I2C0 Base Address = 0xFFFF0800

Address	Name	Byte	Access Type	Cycle
0x0800	I2C0MSTA	1	R	2
0x0804	I2C0SSTA	1	R	2
0x0808	I2C0SRX	1	R	2
0x080C	I2C0STX	1	W	2
0x0810	I2C0MRX	1	R	2
0x0814	I2C0MTX	1	W	2
0x0818	I2C0CNT	1	R/W	2
0x081C	I2C0ADR	1	R/W	2
0x0824	I2C0BYT	1	R/W	2
0x0828	I2C0ALT	1	R/W	2
0x082C	I2C0CFG	1	R/W	2
0x0830	I2C0DIV	2	R/W	2
0x0838	I2C0ID0	1	R/W	2
0x083C	I2C0ID1	1	R/W	2
0x0840	I2C0ID2	1	R/W	2
0x0844	I2C0ID3	1	R/W	2
0x0848	I2C0SSC	1	R/W	2
0x084C	I2C0FIF	1	R/W	2

Table 23. I2C1 Base Address = 0xFFFF0900

Address	Name	Byte	Access Type	Cycle
0x0900	I2C1MSTA	1	R	2
0x0904	I2C1SSTA	1	R	2
0x0908	I2C1SRX	1	R	2
0x090C	I2C1STX	1	W	2
0x0910	I2C1MRX	1	R	2
0x0914	I2C1MTX	1	W	2
0x0918	I2C1CNT	1	R/W	2
0x091C	I2C1ADR	1	R/W	2
0x0924	I2C1BYT	1	R/W	2
0x0928	I2C1ALT	1	R/W	2
0x092C	I2C1CFG	1	R/W	2
0x0930	I2C1DIV	2	R/W	2
0x0938	I2C1ID0	1	R/W	2
0x093C	I2C1ID1	1	R/W	2
0x0940	I2C1ID2	1	R/W	2
0x0944	I2C1ID3	1	R/W	2
0x0948	I2C1SSC	1	R/W	2
0x094C	I2C1FIF	1	R/W	2

Table 24. SPI Base Address = 0xFFFF0A00

Address	Name	Byte	Access Type	Cycle
0x0A00	SPISTA	1	R	2
0x0A04	SPIRX	1	R	2
0x0A08	SPLITX	1	W	2
0x0A0C	SPIIDIV	1	R/W	2
0x0A10	SPICON	2	R/W	2

ADuC7128/ADuC7129

Table 25. PLA Base Address = 0xFFFF0B00

Address	Name	Byte	Access Type	Cycle
0x0B00	PLAELM0	2	R/W	2
0x0B04	PLAELM1	2	R/W	2
0x0B08	PLAELM2	2	R/W	2
0x0B0C	PLAELM3	2	R/W	2
0x0B10	PLAELM4	2	R/W	2
0x0B14	PLAELM5	2	R/W	2
0x0B18	PLAELM6	2	R/W	2
0x0B1C	PLAELM7	2	R/W	2
0x0B20	PLAELM8	2	R/W	2
0x0B24	PLAELM9	2	R/W	2
0x0B28	PLAELM10	2	R/W	2
0x0B2C	PLAELM11	2	R/W	2
0x0B30	PLAELM12	2	R/W	2
0x0B34	PLAELM13	2	R/W	2
0x0B38	PLAELM14	2	R/W	2
0x0B3C	PLAELM15	2	R/W	2
0x0B40	PLACK	1	R/W	2
0x0B44	PLAIRQ	4	R/W	2
0x0B48	PLADC	4	R/W	2
0x0B4C	PLADIN	4	R/W	2
0x0B50	PLAOUT	4	R	2

Table 26. External Memory Base Address = 0xFFFF0C00

Address	Name	Byte	Access Type	Cycle
0x0C00	XMCFG	1	R/W	2
0x0C10	XM0CON	1	R/W	2
0x0C14	XM1CON	1	R/W	2
0x0C18	XM2CON	1	R/W	2
0x0C1C	XM3CON	1	R/W	2
0x0C20	XM0PAR	2	R/W	2
0x0C24	XM1PAR	2	R/W	2
0x0C28	XM2PAR	2	R/W	2
0x0C2C	XM3PAR	2	R/W	2

Table 27. GPIO Base Address = 0xFFFF0D00

Address	Name	Byte	Access Type	Cycle
0x0D00	GP0CON	4	R/W	1
0x0D04	GP1CON	4	R/W	1
0x0D08	GP2CON	4	R/W	1
0x0D0C	GP3CON	4	R/W	1
0x0D10	GP4CON	4	R/W	1
0x0D20	GP0DAT	4	R/W	1
0x0D24	GP0SET	1	W	1
0x0D28	GP0CLR	1	W	1
0x0D2C	GP0PAR	4	R/W	1
0x0D30	GP1DAT	4	R/W	1
0x0D34	GP1SET	1	W	1
0x0D38	GP1CLR	1	W	1
0x0D3C	GP1PAR	4	R/W	1
0x0D40	GP2DAT	4	R/W	1
0x0D44	GP2SET	1	W	1
0x0D48	GP2CLR	1	W	1
0x0D50	GP3DAT	4	R/W	1
0x0D54	GP3SET	1	W	1
0x0D58	GP3CLR	1	W	1
0x0D5C	GP3PAR	4	R/W	1
0x0D60	GP4DAT	4	R/W	1
0x0D64	GP4SET	1	W	1
0x0D68	GP4CLR	1	W	1
0x0D6C	GP4PAR	1	W	1

Table 28. Flash/EE Block 0 Base Address = 0xFFFF0E00

Address	Name	Byte	Access Type	Cycle
0x0E00	FEE0STA	1	R	1
0x0E04	FEE0MOD	1	R/W	1
0x0E08	FEE0CON	1	R/W	1
0x0E0C	FEE0DAT	2	R/W	1
0x0E10	FEE0ADR	2	R/W	1
0x0E18	FEE0SGN	3	R	1
0x0E1C	FEE0PRO	4	R/W	1
0x0E20	FEE0HID	4	R/W	1

Table 29. Flash/EE Block 1 Base Address = 0xFFFF0E80

Address	Name	Byte	Access Type	Cycle
0x0E80	FEE1STA	1	R	1
0x0E84	FEE1MOD	1	R/W	1
0x0E88	FEE1CON	1	R/W	1
0x0E8C	FEE1DAT	2	R/W	1
0x0E90	FEE1ADR	2	R/W	1
0x0E98	FEE1SGN	3	R	1
0x0E9C	FEE1PRO	4	R/W	1
0x0EA0	FEE1HID	4	R/W	1

Table 30. QEN Base Address = 0xFFFF0F00

Address	Name	Byte	Access Type	Cycle
0x0F00	QENCON	2	R/W	2
0x0F04	QENSTA	1	R	2
0x0F08	QENDAT	2	R/W	2
0x0F0C	QENVAL	2	R	2
0x0F14	QENCLR	1	W	2
0x0F18	QENSET	1	W	2

Table 31. PWM Base Address = 0xFFFF0F80

Address	Name	Byte	Access Type	Cycle
0x0F80	PWMCON1	2	R/W	2
0x0F84	PWM1COM1	2	R/W	2
0x0F88	PWM1COM2	2	R/W	2
0x0F8C	PWM1COM3	2	R/W	2
0x0F90	PWM1LEN	2	R/W	2
0x0F94	PWM2COM1	2	R/W	2
0x0F98	PWM2COM2	2	R/W	2
0x0F9C	PWM2COM3	2	R/W	2
0x0FA0	PWM2LEN	2	R/W	2
0x0FA4	PWM3COM1	2	R/W	2
0x0FA8	PWM3COM2	2	R/W	2
0x0FAC	PWM3COM3	2	R/W	2
0x0FB0	PWM3LEN	2	R/W	2
0x0FB4	PWMCON2	2	R/W	2
0x0FB8	PWMICLR	2	W	2

ADC CIRCUIT OVERVIEW

The analog-to-digital converter (ADC) incorporates a fast, multichannel, 12-bit ADC. It can operate from 3.0 V to 3.6 V supplies and is capable of providing a throughput of up to 1 MSPS when the clock source is 41.78 MHz. This block provides the user with a multichannel multiplexer, differential track-and-hold, on-chip reference, and ADC.

The ADC consists of a 12-bit successive approximation converter based around two capacitor DACs. Depending on the input signal configuration, the ADC can operate in one of the following three modes:

- Fully differential mode, for small and balanced signals
- Single-ended mode, for any single-ended signals
- Pseudo differential mode, for any single-ended signals, taking advantage of the common mode rejection offered by the pseudo differential input

The converter accepts an analog input range of 0 to V_{REF} when operating in single-ended mode or pseudo differential mode. In fully differential mode, the input signal must be balanced around a common-mode voltage V_{CM} , in the range 0 V to AV_{DD} and with a maximum amplitude of $2 V_{REF}$ (see Figure 32).



Figure 32. Examples of Balanced Signals for Fully Differential Mode

A high precision, low drift, and factory-calibrated 2.5 V reference is provided on-chip. An external reference can also be connected as described in the Band Gap Reference section.

Single or continuous conversion modes can be initiated in software. An external CONVST pin, an output generated from the on-chip PLA, a Timer0, or a Timer1 overflow can also be used to generate a repetitive trigger for ADC conversions.

If the signal has not been deasserted by the time the ADC conversion is complete, a second conversion begins automatically.

A voltage output from an on-chip band gap reference proportional to absolute temperature can also be routed through the front-end ADC multiplexer, effectively an additional ADC channel input. This facilitates an internal temperature sensor channel, measuring die temperature to an accuracy of $\pm 3^\circ\text{C}$.

ADC TRANSFER FUNCTION

Pseudo Differential Mode and Single-Ended Mode

In pseudo differential or single-ended mode, the input range is 0 to V_{REF} . The output coding is straight binary in pseudo differential and single-ended modes with

$$\begin{aligned} 1 \text{ LSB} &= FS/4096 \text{ or} \\ &2.5 \text{ V}/4096 = 0.61 \text{ mV or} \\ &610 \mu\text{V when } V_{REF} = 2.5 \text{ V} \end{aligned}$$

The ideal code transitions occur midway between successive integer LSB values (that is, $1/2$ LSB, $3/2$ LSBs, $5/2$ LSBs, ..., $FS - 3/2$ LSBs). The ideal input/output transfer characteristic is shown in Figure 33.

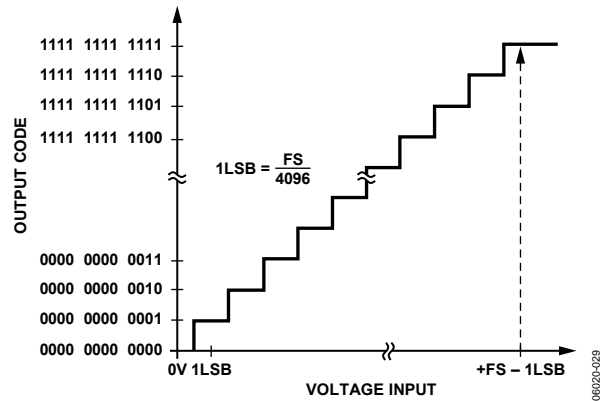

Figure 33. ADC Transfer Function in Pseudo Differential Mode or Single-Ended Mode

Fully Differential Mode

The amplitude of the differential signal is the difference between the signals applied to the V_{IN+} and V_{IN-} pins (that is, $V_{IN+} - V_{IN-}$). The maximum amplitude of the differential signal is, therefore, $-V_{REF}$ to $+V_{REF}$ p-p ($2 \times V_{REF}$). This is regardless of the common mode (CM). The common mode is the average of the two signals ($V_{IN+} + V_{IN-}$)/2, and is, therefore, the voltage upon which the two inputs are centered. This results in the span of each input being $CM \pm V_{REF}/2$. This voltage has to be set up externally, and its range varies with V_{REF} (see the Driving the Analog Inputs section).

The output coding is two's complement in fully differential mode with $1 \text{ LSB} = 2 V_{REF}/4096$ or $2 \times 2.5 \text{ V}/4096 = 1.22 \text{ mV}$ when $V_{REF} = 2.5 \text{ V}$. The output result is ± 11 bits, but this is shifted by one to the right. This allows the result in ADCDAT to be declared as a signed integer when writing C code. The designed code transitions occur midway between successive integer LSB values (that is, $1/2$ LSB, $3/2$ LSBs, $5/2$ LSBs, ..., $FS - 3/2$ LSBs). The ideal input/output transfer characteristic is shown in Figure 34.

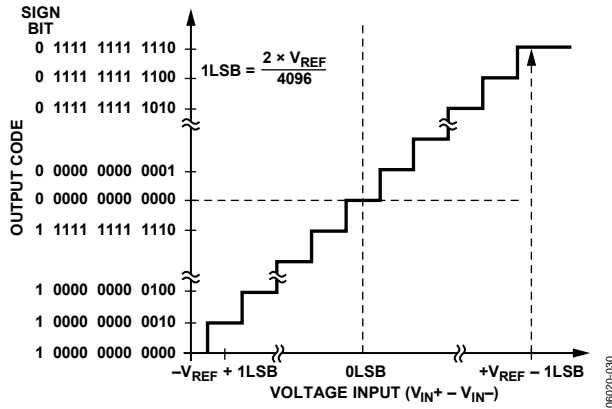

Figure 34. ADC Transfer Function in Differential Mode

TYPICAL OPERATION

Once configured via the ADC control and channel selection registers, the ADC converts the analog input and provides an 11-bit result in the ADC data register.

The top four bits are the sign bits, and the 12-bit result is placed from Bit 16 to Bit 27, as shown in Figure 35. For fully differential mode, the result is ± 11 bits. Again, it should be noted that in fully differential mode, the result is represented in two's complement format shifted one bit to the right, and in pseudo differential and single-ended mode, the result is represented in straight binary format.

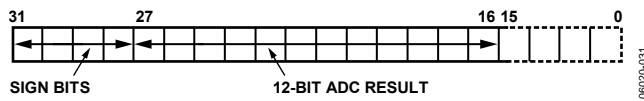

Figure 35. ADC Result Format

ADC MMRs Interface

The ADC is controlled and configured via a number of MMRs (see Table 32) that are described in detail in the following pages.

Table 32. ADC MMRs

Name	Description
ADCCON	ADC Control Register. Allows the programmer to enable the ADC peripheral, to select the mode of operation of the ADC (either single-ended, pseudo differential, or fully differential mode), and to select the conversion type (see Table 33).
ADCCP	ADC Positive Channel Selection Register.
ADCCN	ADC Negative Channel Selection Register.
ADCSTA	ADC Status Register. Indicates when an ADC conversion result is ready. The ADCSTA register contains only one bit, ADCREADY (Bit 0), representing the status of the ADC. This bit is set at the end of an ADC conversion generating an ADC interrupt. It is cleared automatically by reading the ADCDAT MMR. When the ADC is performing a conversion, the status of the ADC can be read externally via the ADC _{Busy} pin. This pin is high during a conversion. When the conversion is finished, ADC _{Busy} goes back low. This information can be available on P0.5 (see the General-Purpose I/O section) if enabled in the GP0CON register.
ADCDAT	ADC Data Result Register. Holds the 12-bit ADC result, as shown in Table 35.
ADCRST	ADC Reset Register. Resets all the ADC registers to their default values.

Current Consumption

The ADC in standby mode, that is, powered up but not converting, typically consumes 640 μ A. The internal reference adds 140 μ A. During conversion, the extra current is 0.3 μ A, multiplied by the sampling frequency (in kHz).

Timing

Figure 36 gives details of the ADC timing. Users control the ADC clock speed and the number of acquisition clock in the ADCCON MMR. By default, the acquisition time is eight clocks and the clock divider is two. The number of extra clocks (such as bit trial or write) is set to 19, giving a sampling rate of 774 kSPS. For conversion on the temperature sensor, the ADC acquisition time is automatically set to 16 clocks and the ADC clock divider is set to 32. When using multiple channels, including the temperature sensor, the timing settings revert back to the user-defined settings after reading the temperature sensor channel.

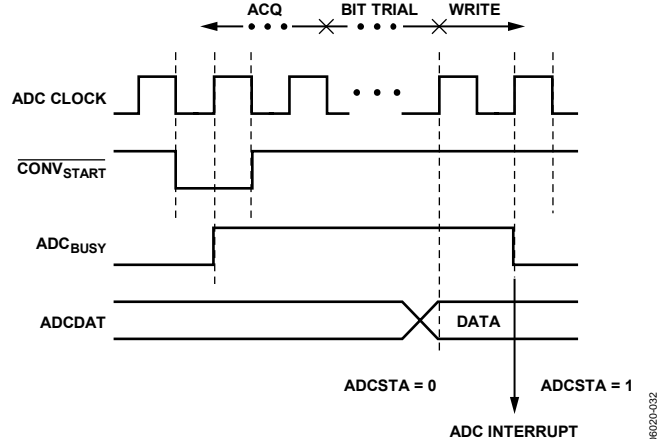

Figure 36. ADC Timing

ADuC7128/ADuC7129

Table 33. ADCCON MMR Bit Designations

Bit	Value	Description
12:10		ADC Clock Speed ($f_{ADC} = F_{CORE}$, Conversion = 19 ADC Clocks + Acquisition Time).
	000	$f_{ADC}/1$. This divider is provided to obtain 1 MSPS ADC with an external clock <41.78 MHz.
	001	$f_{ADC}/2$ (default value).
	010	$f_{ADC}/4$.
	011	$f_{ADC}/8$.
	100	$f_{ADC}/16$.
	101	$f_{ADC}/32$.
9:8		ADC Acquisition Time (Number of ADC Clocks).
	00	2 clocks.
	01	4 clocks.
	10	8 clocks (default value).
	11	16 clocks.
7		Enable Conversion. Set by user to enable conversion mode. Cleared by user to disable conversion mode.
6		Reserved. This bit should be set to 0 by the user.
5		ADC Power Control. Set by user to place the ADC in normal mode. The ADC must be powered up for at least 5 μ s before it converts correctly. Cleared by user to place the ADC in power-down mode.
4:3		Conversion Mode.
	00	Single-ended Mode.
	01	Differential Mode.
	10	Pseudo Differential Mode.
	11	Reserved.
2:0		Conversion Type.
	000	Enable \overline{CONVST} pin as a conversion input.
	001	Enable Timer1 as a conversion input.
	010	Enable Timer0 as a conversion input.
	011	Single Software Conversion. Set to 000 after conversion. Bit 7 of ADCCON MMR should be cleared after starting a single software conversion to avoid further conversions triggered by the \overline{CONVST} pin.
	100	Continuous Software Conversion.
	101	PLA Conversion.
	110	PWM Conversion.
Other	Reserved.	

Table 34. ADCCP¹ MMR Bit Designations

Bit	Value	Description
7:5		Reserved
4:0		Positive Channel Selection Bits
	00000	ADC0
	00001	ADC1
	00010	ADC2
	00011	ADC3
	00100	ADC4
	00101	ADC5
	00110	ADC6
	00111	ADC7
	01000	ADC8
	01001	ADC9
	01010	ADC10
	01011	ADC11
	01100	ADC12/LD2TX ²
	01101	ADC13/LD1TX ²
	01110	Reserved
	01111	Reserved
	10000	Temperature Sensor
	10001	AGND
	10010	Reference
	10011	AV _{DD} /2
	Others	Reserved

¹ ADC channel availability depends on part model.

² Because ADC12 and ADC13 are shared with the line driver TX pins, a high level of crosstalk is seen on these pins when used in ADC mode.

Table 35. ADCCN¹ MMR Bit Designations

Bit	Value	Description
7:5		Reserved
4:0		Negative Channel Selection Bits
	00000	ADC0
	00001	ADC1
	00010	ADC2
	00011	ADC3
	00100	ADC4
	00101	ADC5
	00110	ADC6
	00111	ADC7
	01000	ADC8
	01001	ADC9
	01010	ADC10
	01011	ADC11
	01100	ADC12/LD2TX
	01101	ADC13/LD1TX
	01110	Reserved
	01111	Reserved
	10000	Temperature Sensor
	Others	Reserved

¹ ADC channel availability depends on part model.

Table 36. ADCSTA MMR Bit Designations

Bit	Value	Description
0	1	Indicates that an ADC conversion is complete. It is set automatically once an ADC conversion completes.
0	0	Automatically cleared by reading the ADCDAT MMR.

Table 37. ADCDAT MMR Bit Designations

Bit	Value	Description
27:16		Holds the ADC result (see Figure 35).

Table 38. ADCRST MMR Bit Designations

Bit	Value	Description
0	1	Set to 1 by the user to reset all the ADC registers to their default values.

ADuC7128/ADuC7129

CONVERTER OPERATION

The ADC incorporates a successive approximation (SAR) architecture involving a charge-sampled input stage. This architecture is described for the three different modes of operation: differential mode, pseudo differential mode, and single-ended mode.

Differential Mode

The ADuC7128/ADuC7129 contain a successive approximation ADC based on two capacitive DACs. Figure 37 and Figure 38 show simplified schematics of the ADC in acquisition and conversion phase, respectively. The ADC comprises control logic, a SAR, and two capacitive DACs. In Figure 37 (the acquisition phase), SW3 is closed and SW1 and SW2 are in Position A. The comparator is held in a balanced condition, and the sampling capacitor arrays acquire the differential signal on the input.



Figure 37. ADC Acquisition Phase

When the ADC starts a conversion (see Figure 38), SW3 opens and SW1 and SW2 move to Position B, causing the comparator to become unbalanced. Both inputs are disconnected once the conversion begins. The control logic and the charge redistribution DACs are used to add and subtract fixed amounts of charge from the sampling capacitor arrays to bring the comparator back into a balanced condition. When the comparator is rebalanced, the conversion is complete. The control logic generates the ADC output code. The output impedances of the sources driving the V_{IN+} pin and the V_{IN-} pin must be matched; otherwise, the two inputs have different settling times, resulting in errors.



Figure 38. ADC Conversion Phase

Pseudo Differential Mode

In pseudo differential mode, Channel- is linked to the V_{IN-} pin of the ADuC7128/ADuC7129, and SW2 switches between A (Channel-) and B (V_{REF}). The V_{IN-} pin must be connected to ground or a low voltage. The input signal on V_{IN+} can then vary from V_{IN-} to $V_{REF} + V_{IN-}$. Note that V_{IN-} must be chosen so that $V_{REF} + V_{IN-}$ does not exceed AV_{DD} .



Figure 39. ADC in Pseudo Differential Mode

Single-Ended Mode

In single-ended mode, SW2 is always connected internally to ground. The V_{IN-} pin can be floating. The input signal range on V_{IN+} is 0 V to V_{REF} .



Figure 40. ADC in Single-Ended Mode

Analog Input Structure

Figure 41 shows the equivalent circuit of the analog input structure of the ADC. The four diodes provide ESD protection for the analog inputs. Care must be taken to ensure that the analog input signals never exceed the supply rails by more than 300 mV. Voltage in excess of 300 mV would cause these diodes to become forward biased and start conducting into the substrate. These diodes can conduct up to 10 mA without causing irreversible damage to the part.

The C1 capacitors in Figure 41 are typically 4 pF and can be primarily attributed to pin capacitance. The resistors are lumped components made up of the on resistance of the switches. The value of these resistors is typically about 100 Ω . The C2 capacitors are the ADC sampling capacitors and have a capacitance of 16 pF typical.



Figure 41. Equivalent Analog Input Circuit
Conversion Phase: Switches Open, Track Phase: Switches Closed

For ac applications, removing high frequency components from the analog input signal is recommended through the use of an RC low-pass filter on the relevant analog input pins. In applications where harmonic distortion and signal-to-noise ratio are critical, the analog input should be driven from a low impedance source. Large source impedances significantly affect the ac performance of the ADC and can necessitate the use of an input buffer amplifier. The choice of the op amp is a function of the particular application. Figure 42 and Figure 43 give an example of an ADC front end.

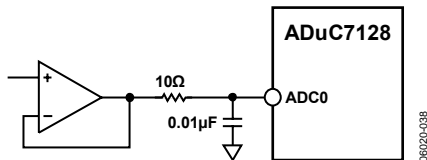

Figure 42. Buffering Single-Ended/Pseudo Differential Input



Figure 43. Buffering Differential Inputs

When no amplifier is used to drive the analog input, the source impedance should be limited to values lower than 1 kΩ. The maximum source impedance depends on the amount of total harmonic distortion (THD) that can be tolerated. The THD increases as the source impedance increases and the performance degrades.

DRIVING THE ANALOG INPUTS

Internal or external reference can be used for the ADC. In differential mode of operation, there are restrictions on the common-mode input signal (V_{CM}) that are dependent on the reference value and supply voltage used to ensure that the signal remains within the supply rails. Table 39 gives some calculated V_{CM} minimum and V_{CM} maximum values.

Table 39. V_{CM} Ranges

AV_{DD}	V_{REF}	V_{CM} Min	V_{CM} Max	Signal Peak-to-Peak
3.3 V	2.5 V	1.25 V	2.05 V	2.5 V
	2.048 V	1.024 V	2.276 V	2.048 V
	1.25 V	0.75 V	2.55 V	1.25 V
3.0 V	2.5 V	1.25 V	1.75 V	2.5 V
	2.048 V	1.024 V	1.976 V	2.048 V
	1.25 V	0.75 V	2.25 V	1.25 V

TEMPERATURE SENSOR

The ADuC7128/ADuC7129 provide a voltage output from an on-chip band gap reference proportional to absolute temperature. The voltage output can also be routed through the front end ADC multiplexer (effectively an additional ADC channel input), facilitating an internal temperature sensor channel, measuring die temperature to an accuracy of $\pm 3^{\circ}\text{C}$.

The following is a code example of how to configure the ADC for use with the temperature sensor:

```
int main(void)
{
    float a = 0;
    short b;
    ADCCON = 0x20;           // power-on the ADC
    delay(2000);
    ADCCP = 0x10; // Select Temperature Sensor as
                  // an input to the ADC
    REFCON = 0x01; // connect internal 2.5V
                  // reference to Vref pin
    ADCCON = 0xE4; // continuous conversion

    while(1)
    {
        while (!ADCSTA){};
        b = (ADCDAT >> 16);
        // To calculate temperature in °C, use
        the formula:
        a = 0x525 - b;
        // ((Temperature = 0x525 - Sensor
        Voltage) / 1.3)
        a /= 1.3;
        b = floor(a);
        printf("Temperature: %d oC\n",b);
    }
    return 0;
}
```

ADuC7128/ADuC7129

BAND GAP REFERENCE

The ADuC7128/ADuC7129 provide an on-chip band gap reference of 2.5 V that can be used for the ADC and for the DAC. This internal reference also appears on the V_{REF} pin. When using the internal reference, a capacitor of 0.47 μ F must be connected from the external V_{REF} pin to AGND to ensure stability and fast response during ADC conversions. This reference can also be connected to an external pin (V_{REF}) and used as a reference for other circuits in the system.

An external buffer is required because of the low drive capability of the V_{REF} output. A programmable option also allows an external reference input on the V_{REF} pin. Note that it is not possible to disable the internal reference. Therefore, the external reference source must be capable of overdriving the internal reference source.

The band gap reference interface consists of an 8-bit REFCON MMR, described in Table 40.

Table 40. REFCON MMR Bit Designations

Bit	Description
7:1	Reserved.
0	Internal Reference Output Enable. Set by user to connect the internal 2.5 V reference to the V_{REF} pin. The reference can be used for external components but needs to be buffered. Cleared by user to disconnect the reference from the V_{REF} pin. Note: The on-chip DAC is functional only with the internal reference output enable bit set. It does not work with an external reference.

NONVOLATILE FLASH/EE MEMORY

FLASH/EE MEMORY OVERVIEW

The ADuC7128/ADuC7129 incorporate Flash/EE memory technology on-chip to provide the user with nonvolatile, in-circuit reprogrammable memory space.

Like EEPROM, Flash memory can be programmed in-system at a byte level, although it must first be erased. The erase is performed in page blocks. As a result, Flash memory is often, and more correctly, referred to as Flash/EE memory.

Overall, Flash/EE memory represents a step closer to the ideal memory device that includes nonvolatility, in-circuit programmability, high density, and low cost. Incorporated in the ADuC7128/ADuC7129, Flash/EE memory technology allows the user to update program code space in-circuit, without the need to replace one-time programmable (OTP) devices at remote operating nodes.

FLASH/EE MEMORY

The ADuC7128/ADuC7129 contain two 64 kB arrays of Flash/EE memory. In the first block, the lower 62 kB are available to the user and the upper 2 kB of this Flash/EE program memory array contain permanently embedded firmware, allowing in-circuit serial download. The 2 kB of embedded firmware also contain a power-on configuration routine that downloads factory calibrated coefficients to the various calibrated peripherals, such as band gap references. This 2 kB embedded firmware is hidden from user code. It is not possible for the user to read, write, or erase this page. In the second block, all 64 kB of Flash/EE memory are available to the user.

The 126 kB of Flash/EE memory can be programmed in-circuit, using the serial download mode or the JTAG mode provided.

Flash/EE Memory Reliability

The Flash/EE memory arrays on the parts are fully qualified for two key Flash/EE memory characteristics: Flash/EE memory cycling endurance and Flash/EE memory data retention.

Endurance quantifies the ability of the Flash/EE memory to be cycled through many program, read, and erase cycles. A single endurance cycle is composed of four independent, sequential events, defined as

1. Initial page erase sequence
2. Read/verify, sequence a single Flash/EE location
3. Byte program sequence memory
4. Second read/verify sequence endurance cycle

In reliability qualification, every half word (16-bit wide) location of the three pages (top, middle, and bottom) in the Flash/EE memory is cycled 10,000 times from 0x0000 to 0xFFFF.

As indicated in Table 1 of the Specifications section, the Flash/EE memory endurance qualification is carried out in accordance with JEDEC Retention Lifetime Specification A117 over the industrial temperature range of -40° to $+125^{\circ}\text{C}$. The results allow the specification of a minimum endurance figure over a supply temperature of 10,000 cycles.

Retention quantifies the ability of the Flash/EE memory to retain its programmed data over time. Again, the parts are qualified in accordance with the formal JEDEC Retention Lifetime Specification (A117) at a specific junction temperature ($T_J = 85^{\circ}\text{C}$). As part of this qualification procedure, the Flash/EE memory is cycled to its specified endurance limit, described previously, before data retention is characterized. This means that the Flash/EE memory is guaranteed to retain its data for its fully specified retention lifetime every time the Flash/EE memory is reprogrammed. Note, too, that retention lifetime, based on an activation energy of 0.6 eV, derates with T_J , as shown in Figure 44.



Figure 44. Flash/EE Memory Data Retention

Serial Downloading (In-Circuit Programming)

The ADuC7128/ADuC7129 facilitate code download via the standard UART serial port. The ADuC7128/ADuC7129 enter serial download mode after a reset or power cycle if the **BM** pin is pulled low through an external 1 k Ω resistor. Once in serial download mode, the user can download code to the full 126 kB of Flash/EE memory while the device is in-circuit in its target application hardware. A PC serial download executable is provided as part of the development system for serial downloads via the UART.

For additional information, an application note is available at www.analog.com/microconverter describing the protocol for serial downloads via the UART.

JTAG Access

The JTAG protocol uses the on-chip JTAG interface to facilitate code download and debug.

FLASH/EE MEMORY SECURITY

The 126 kB of Flash/EE memory available to the user can be read and write protected. Bit 31 of the FEE0PRO/FEE0HID MMR protects the 126 kB from being read through JTAG and also in parallel programming mode. The other 31 bits of this register protect writing to the Flash/EE memory; each bit protects four pages, that is, 2 kB. Write protection is activated for all access types. FEE1PRO and FEE1HID similarly protect the second 64 kB block. All 32 bits of this are used to protect four pages at a time.

Three Levels of Protection

Protection can be set and removed by writing directly into FEE0HID MMR. This protection does not remain after reset.

Protection can be set by writing into FEE0PRO MMR. It takes effect only after a save protection command (0x0C) and a reset. The FEE0PRO MMR is protected by a key to avoid direct access. The key is saved once and must be entered again to modify FEE0PRO. A mass erase sets the key back to 0xFFFF but also erases all the user code.

The Flash/EE memory can be permanently protected by using the FEEPRO MMR and a particular value of the 0xDEADDEAD key. Entering the key again to modify the FEE0PRO register is not allowed.

Sequence to Write the Key

1. Write the bit in FEE0PRO corresponding to the page to be protected.
2. Enable key protection by setting Bit 6 of FEE0MOD (Bit 5 must equal 0).
3. Write a 32-bit key in FEE0ADR, FEE0DAT.
4. Run the write key command 0x0C in FEE0CON; wait for the read to be successful by monitoring FEE0STA.
5. Reset the part.

To remove or modify the protection, the same sequence is used with a modified value of FEE0PRO. If the key chosen is the value 0xDEAD, then the memory protection cannot be removed. Only a mass erase unprotects the part, but it also erases all user code.

The sequence to write the key is shown in the following example; this protects writing Page 4 to Page 7 of the Flash/EE memory:

```
FEE0PRO=0xFFFFFFFF; //Protect pages 4 to 7
FEE0MOD=0x48; //Write key enable
FEE0ADR=0x1234; //16 bit key value
FEE0DAT=0x5678; //16 bit key value
FEE0CON= 0x0C; // Write key command
```

The same sequence should be followed to protect the part permanently with FEE0ADR = 0xDEAD and FEE0DAT = 0xDEAD.

FLASH/EE CONTROL INTERFACE

FEE0DAT Register

Name	Address	Default Value	Access
FEE0DAT	0xFFFF0E0C	0XXXXX	R/W

FEE0DAT is a 16-bit data register.

FEE0ADR Register

Name	Address	Default Value	Access
FEE0ADR	0xFFFF0E10	0x0000	R/W

FEE0ADR is a 16-bit address register.

FEE0SGN Register

Name	Address	Default Value	Access
FEE0SGN	0xFFFF0E18	0FFFFFFF	R

FEE0SGN is a 24-bit code signature.

FEE0PRO Register

Name	Address	Default Value	Access
FEE0PRO	0xFFFF0E1C	0x00000000	R/W

FEE0PRO provides protection following subsequent reset MMR. It requires a software key (see Table 44).

FEE0HID Register

Name	Address	Default Value	Access
FEE0HID	0xFFFF0E20	0xFFFFFFFF	R/W

FEE0HID provides immediate protection MMR. It does not require any software keys (see Table 44).

Command Sequence for Executing a Mass Erase

```
FEE0DAT = 0x3CFF;
FEE0ADR = 0xFFC3;
FEE0MOD = FEE0MOD|0x8; //Erase key enable
FEE0CON = 0x06; //Mass erase command
```

FEE1DAT Register

Name	Address	Default Value	Access
FEE1DAT	0xFFFF0E8C	0XXXXX	R/W

FEE1DAT is a 16-bit data register.

FEE1ADR Register

Name	Address	Default Value	Access
FEE1ADR	0xFFFF0E90	0x0000	R/W

FEE1ADR is a 16-bit address register.

FEE1SGN Register

Name	Address	Default Value	Access
FEE1SGN	0xFFFF0E98	0FFFFFFF	R

FEE1SGN is a 24-bit code signature.

FEE1PRO Register

Name	Address	Default Value	Access
FEE1PRO	0xFFFF0E9C	0x00000000	R/W

FEE1PRO provides protection following subsequent reset MMR. It requires a software key (see Table 45).

FEE1HID Register

Name	Address	Default Value	Access
FEE1HID	0xFFFF0EA0	0xFFFFFFFF	R/W

FEE1HID provides immediate protection MMR. It does not require any software keys (see Table 45).

FEE0STA Register

Name	Address	Default Value	Access
FEE0STA	0xFFFF0E00	0x0000	R/W

FEE1STA Register

Name	Address	Default Value	Access
FEE1STA	0xFFFF0E80	0x0000	R/W

FEE0MOD Register

Name	Address	Default Value	Access
FEE0MOD	0xFFFF0E04	0x80	R/W

FEE1MOD Register

Name	Address	Default Value	Access
FEE1MOD	0xFFFF0E84	0x80	R/W

FEE0CON Register

Name	Address	Default Value	Access
FEE0CON	0xFFFF0E08	0x0000	R/W

FEE1CON Register

Name	Address	Default Value	Access
FEE1CON	0xFFFF0E88	0x0000	R/W

ADuC7128/ADuC7129

Table 41. FEEExSTA MMR Bit Designations

Bit	Description
15:6	Reserved.
5	Reserved.
4	Reserved.
3	Flash/EE Interrupt Status Bit. Set automatically when an interrupt occurs, that is, when a command is complete and the Flash/EE interrupt enable bit in the FEEExMOD register is set. Cleared when reading FEEExSTA register.
2	Flash/EE Controller Busy. Set automatically when the controller is busy. Cleared automatically when the controller is not busy.
1	Command Fail. Set automatically when a command completes unsuccessfully. Cleared automatically when reading FEEExSTA register.
0	Command Complete. Set by MicroConverter when a command is complete. Cleared automatically when reading FEEExSTA register.

Table 42. FEEExMOD MMR Bit Designations

Bit	Description
7:5	Reserved.
4	Flash/EE Interrupt Enable. Set by user to enable the Flash/EE interrupt. The interrupt occurs when a command is complete. Cleared by user to disable the Flash/EE interrupt
3	Erase/Write Command Protection. Set by user to enable the erase and write commands. Cleared to protect the Flash/EE memory against erase/write command.
2	Reserved. Should always be set to 0 by the user.
1:0	Flash/EE Wait States. Both Flash/EE blocks must have the same wait state value for any change to take effect.

Table 43. Command Codes in FEEExCON

Code	Command	Description
0x00 ¹	Null	Idle State.
0x01 ¹	Single read	Load FEEExDAT with the 16-bit data indexed by FEEExADR.
0x02 ¹	Single write	Write FEEExDAT at the address pointed by FEEExADR. This operation takes 50 μ s.
0x03 ¹	Erase/Write	Erase the page indexed by FEEExADR and write FEEExDAT at the location pointed by FEEExADR. This operation takes 20 ms.
0x04 ¹	Single verify	Compare the contents of the location pointed by FEEExADR to the data in FEEExDAT. The result of the comparison is returned in FEEExSTA Bit 1.
0x05 ¹	Single erase	Erase the page indexed by FEEExADR.
0x06 ¹	Mass erase	Erase user space. The 2 kB of kernel are protected in Block 0. This operation takes 2.48 sec. To prevent accidental execution, a command sequence is required to execute this instruction.
0x07	Reserved	Reserved.
0x08	Reserved	Reserved.
0x09	Reserved	Reserved.
0x0A	Reserved	Reserved.
0x0B	Signature	Gives a signature of the 64 kB of Flash/EE in the 24-bit FEEExSIGN MMR. This operation takes 32,778 clock cycles.
0x0C	Protect	This command can be run only once. The value of FEEExPRO is saved and can be removed only with a mass erase (0x06) or with the key.
0x0D	Reserved	Reserved.
0x0E	Reserved	Reserved.
0x0F	Ping	No Operation, Interrupt Generated.

¹ The FEEExCON register always reads 0x07 immediately after execution of any of these commands.

Table 44. FEE0PRO and FEE0HID MMR Bit Designations

Bit	Description
31	Read Protection. Cleared by user to protect Block 0. Set by user to allow reading Block 0.
30:0	Write Protection for Page 123 to Page 120, for Page 119 to Page 116, and for Page 3 to Page 0. Cleared by user to protect the pages in writing. Set by user to allow writing the pages.

Table 45. FEE1PRO and FEE1HID MMR Bit Designations

Bit	Description
31	Read Protection. Cleared by user to protect Block 1. Set by user to allow reading Block 1.
30	Write Protection for Page 127 to Page 120. Cleared by user to protect the pages in writing. Set by user to allow writing the pages.
31:0	Write Protection for Page 119 to Page 116 and for Page 3 to Page 0. Cleared by user to protect the pages in writing. Set by user to allow writing the pages.

EXECUTION TIME FROM SRAM AND FLASH/EE

This section describes SRAM and Flash/EE access times during execution for applications where execution time is critical.

Execution from SRAM

Fetching instructions from SRAM takes one clock cycle because the access time of the SRAM is 2 ns and a clock cycle is 22 ns minimum. However, if the instruction involves reading or writing data to memory, one extra cycle must be added if the data is in SRAM (or three cycles if the data is in Flash/EE), one cycle to execute the instruction and two cycles to get the 32-bit data from Flash/EE. A control flow instruction, such as a branch instruction, takes one cycle to fetch, but it also takes two cycles to fill the pipeline with the new instructions.

Execution from Flash/EE

Because the Flash/EE width is 16 bits and access time for 16-bit words is 23 ns, execution from Flash/EE cannot be done in one cycle (as can be done from SRAM when the CD bit = 0). In addition, some dead times are needed before accessing data for any value of CD bits.

In ARM mode, where instructions are 32 bits, two cycles are needed to fetch any instruction when CD = 0. In Thumb mode, where instructions are 16 bits, one cycle is needed to fetch any instruction.

Timing is identical in both modes when executing instructions that involve using the Flash/EE for data memory. If the instruction to be executed is a control flow instruction, an extra cycle is needed to decode the new address of the program counter and then four cycles are needed to fill the pipeline. A data processing instruction involving only core registers doesn't require any extra clock cycles, but if it involves data in Flash/EE, an extra clock cycle is needed to decode the address of the data and two cycles to get the 32-bit data from Flash/EE. An extra cycle must also be added before fetching another instruction. Data transfer instructions are more complex and are summarized in Table 46.

Table 46. Execution Cycles in ARM/Thumb Mode

Instructions	Fetch Cycles	Dead Time	Data Access	Dead Time
LD	2/1	1	2	1
LDH	2/1	1	1	1
LDM/PUSH	2/1	N	$2 \times N$	N
STR	2/1	1	$2 \times 20 \mu\text{s}$	1
STRH	2/1	1	$20 \mu\text{s}$	1
STRM/POP	2/1	N	$2 \times N \times 20 \mu\text{s}$	N

With $1 < N \leq 16$, N is the number of bytes of data to load or store in the multiple load/store instruction. The SWAP instruction combines an LD and STR instruction with only one fetch, giving a total of eight cycles plus 40 μs .

ADuC7128/ADuC7129

RESET AND REMAP

The ARM exception vectors are all situated at the bottom of the memory array, from Address 0x00000000 to Address 0x00000020, as shown in Figure 45.



Figure 45. Remap for Exception Execution

By default and after any reset, the Flash/EE is mirrored at the bottom of the memory array. The remap function allows the programmer to mirror the SRAM at the bottom of the memory array, facilitating execution of exception routines from SRAM instead of from Flash/EE. This means exceptions are executed twice as fast, with the exception being executed in ARM mode (32 bits), and the SRAM being 32 bits wide instead of 16-bit wide Flash/EE memory.

Table 47. REMAP MMR Bit Designations

Bit	Name	Description
0	Remap	Remap Bit. Set by user to remap the SRAM to Address 0x00000000. Cleared automatically after reset to remap the Flash/EE memory to Address 0x00000000.

Table 48. RSTSTA MMR Bit Designations

Bit	Description
7:3	Reserved.
2	Software Reset. Set by user to force a software reset. Cleared by setting the corresponding bit in RSTCLR.
1	Watchdog Timeout. Set automatically when a watchdog timeout occurs. Cleared by setting the corresponding bit in RSTCLR.
0	Power-On Reset. Set automatically when a power-on reset occurs. Cleared by setting the corresponding bit in RSTCLR.

Remap Operation

When a reset occurs on the ADuC7128/ADuC7129, execution starts automatically in factory-programmed internal configuration code. This kernel is hidden and cannot be accessed by user code. If the ADuC7128/ADuC7129 are in normal mode (the BM pin is high), they execute the power-on configuration routine of the kernel and then jump to the reset vector Address 0x00000000 to execute the user's reset exception routine. Because the Flash/EE is mirrored at the bottom of the memory array at reset, the reset interrupt routine must always be written in Flash/EE.

The remap is done from Flash/EE by setting Bit 0 of the REMAP register. Precautions must be taken to execute this command from Flash/EE, above Address 0x00080020, and not from the bottom of the array because this is replaced by the SRAM.

This operation is reversible: the Flash/EE can be remapped at Address 0x00000000 by clearing Bit 0 of the REMAP MMR. Precaution must again be taken to execute the remap function from outside the mirrored area. Any kind of reset remaps the Flash/EE memory at the bottom of the array.

Reset Operation

There are four kinds of reset: external reset, power-on reset, watchdog expiration, and software force. The RSTSTA register indicates the source of the last reset and RSTCLR clears the RSTSTA register. These registers can be used during a reset exception service routine to identify the source of the reset. If RSTSTA is null, the reset was external. Note that when clearing RSTSTA, all bits that are currently 1 must be cleared. Otherwise, a reset event occurs.

OTHER ANALOG PERIPHERALS

DAC

The ADuC7128/ADuC7129 feature a 10-bit current DAC that can be used to generate user-defined waveforms or sine waves generated by the DDS. The DAC consists of a 10-bit IDAC followed by a current-to-voltage conversion.

The current output of the IDAC is passed through a resistor and capacitor network where it is both filtered and converted to a voltage. This voltage is then buffered by an op amp and passed to the line driver.

For the DAC to function, the internal 2.5 V voltage reference must be enabled and driven out onto an external capacitor, $REFCON = 0x01$.

Once the DAC is enabled, users see a 5 mV drop in the internal reference value. This is due to bias currents drawn from the reference used in the DAC circuitry. It is recommended that if using the DAC, it be left powered on to avoid seeing variations in ADC results.

Table 49. DACCON MMR Bit Designations

Bit	Value	Description
10:9		Reserved. These bits should be written to 0 by the user.
8		Reserved. This bit should be written to 0 by the user.
7		Reserved. This bit should be written to 0 by the user.
6		Reserved. This bit should be written to 0 by the user.
5		Output Enable. This bit operates in all modes. In Line Driver mode, this bit should be set. Set by user to enable the line driver output. Cleared by user to disable the line driver output. In this mode the line driver output is high impedance.
4		Single-Ended or Differential Output Control. Set by user to operate in differential mode, the output is the differential voltage between LD1TX and LD2TX. The voltage output range is $V_{REF}/2 \pm V_{REF}/2$. Cleared by user to reference the LD1TX output to AGND. The voltage output range is $AV_{DD}/2 \pm V_{REF}/2$.
3		Reserved. This bit should be set to 0 by the user.
2:1		Operation Mode Control. This bit selects the mode of operation of the DAC.
	00	Power-Down.
	01	Reserved.
	10	Reserved.
	11	DDS and DAC Mode. Selected by DACEN.
0		DAC Update Rate Control. This bit has no effect when in DDS mode. Set by user to update the DAC on the negative edge of Timer1. This allows the user to use any one of the core CLK, OSC CLK, baud CLK, or user CLK and divide these down by 1, 16, 256, or 32,768. A user can do waveform generation by writing to the DAC data register from RAM and updating the DAC at regular intervals via Timer1. Cleared by user to update the DAC on the negative edge of HCLK.

ADuC7128/ADuC7129

DACEN Register

Name	Address	Default Value	Access
DACEN	0xFFFF06B8	0x00	R/W

Table 50. DACEN MMR Bit Designations

Bit	Description
7:1	Reserved.
0	Set to 1 by the user to enable DAC mode. Set to 0 by the user to enable DDS mode.

DACDAT Register

Name	Address	Default Value	Access
DACDAT	0xFFFF06B4	0x0000	R/W

Table 51. DACDAT MMR Bit Designations

Bit	Description
15:10	Reserved.
9:0	10-bit data for DAC.

Table 53. DDSCON MMR Bit Designations

Bit	Description																				
7:6	Reserved.																				
5	DDS Output Enable. Set by user to enable the DDS output. This has an effect only if the DDS is selected in DACCON. Cleared by user to disable the DDS output.																				
4	Reserved.																				
3:0	Binary Divide Control.																				
	<table border="1"> <thead> <tr> <th>DIV</th> <th>Scale Ratio</th> </tr> </thead> <tbody> <tr> <td>0000</td> <td>0.000</td> </tr> <tr> <td>0001</td> <td>0.125</td> </tr> <tr> <td>0010</td> <td>0.250</td> </tr> <tr> <td>0011</td> <td>0.375</td> </tr> <tr> <td>0100</td> <td>0.500</td> </tr> <tr> <td>0101</td> <td>0.625</td> </tr> <tr> <td>0110</td> <td>0.750</td> </tr> <tr> <td>0111</td> <td>0.875</td> </tr> <tr> <td>1xxx</td> <td>1.000</td> </tr> </tbody> </table>	DIV	Scale Ratio	0000	0.000	0001	0.125	0010	0.250	0011	0.375	0100	0.500	0101	0.625	0110	0.750	0111	0.875	1xxx	1.000
DIV	Scale Ratio																				
0000	0.000																				
0001	0.125																				
0010	0.250																				
0011	0.375																				
0100	0.500																				
0101	0.625																				
0110	0.750																				
0111	0.875																				
1xxx	1.000																				

The DACDAT MMR controls the output of the DAC. The data written to this register is a ± 9 -bit signed value. This means that 0x0000 represents midscale, 0x0200 represents zero scale, and 0x01FF represents full scale.

DACEN and DACDAT require key access. To write to these MMRs, use the sequences shown in Table 52.

Table 52. DACEN and DACDAT Write Sequences

DACEN	DACDAT
DACKEY0 = 0x07	DACKEY0 = 0x07
DACEN = user value	DACDAT = user value
DACKEY1 = 0xB9	DACKEY1 = 0xB9

DDS

The DDS is used to generate a digital sine wave signal for the DAC on the ADuC7128/ADuC7129. It can be enabled into a free running mode by the user.

Both the phase and frequency can be controlled.

DDSRFQ Register

Name	Address	Default Value	Access
DDSRFQ	0xFFFF0694	0x00000000	R/W

Table 54. DDSRFQ MMR Bit Designations

Bit	Description
31:0	Frequency select word (FSW)

The DDS frequency is controlled via the DDSRFQ MMR. This MMR contains a 32-bit word (FSW) that controls the frequency according to the following formula:

$$Frequency = \frac{FSW \times 20.8896 \text{ MHz}}{2^{32}}$$

DDSPHS Register

Name	Address	Default Value	Access
DDSPHS	0xFFFF0698	0x00000000	R/W

Table 55. DDSPHS MMR Bit Designations

Bit	Description
31:12	Reserved
11:0	Phase

The DDS phase offset is controlled via the DDSPHS MMR. This MMR contains a 12-bit value that controls the phase of the DDS output according to the following formula:

$$Phase \text{ Offset} = \frac{2 \times \pi \times Phase}{2^{12}}$$

POWER SUPPLY MONITOR

The power supply monitor on the ADuC7128/ADuC7129 indicates when the IOV_{DD} supply pin drops below one of two supply trip points. The monitor function is controlled via the PSMCON register (see Table 56). If enabled in the IRQEN or FIQEN register, the monitor interrupts the core using the PSMI bit in the PSMCON MMR. This bit is cleared immediately once CMP goes high. Note that if the interrupt generated is exited before CMP goes high (IOV_{DD} is above the trip point), no further interrupts are generated until CMP returns high. The user should ensure that code execution remains within the ISR until CMP returns high.

Table 56. PSMCON MMR Bit Designations

Bit	Name	Description
3	CMP	Comparator Bit. This is a read-only bit that directly reflects the state of the comparator. Read 1 indicates the IOV _{DD} supply is above its selected trip point or the PSM is in power-down mode. Read 0 indicates the IOV _{DD} supply is below its selected trip point. This bit should be set before leaving the interrupt service routine.
2	TP	Trip Point Selection Bit. 0 = 2.79 V 1 = 3.07 V
1	PSMEN	Power Supply Monitor Enable Bit. Set to 1 by the user to enable the power supply monitor circuit. Cleared to 0 by the user to disable the power supply monitor circuit.
0	PSMI	Power Supply Monitor Interrupt Bit. This bit is set high by the MicroConverter if CMP is low, indicating low I/O supply. The PSMI bit can be used to interrupt the processor. Once CMP returns high, the PSMI bit can be cleared by writing a 1 to this location. A write of 0 has no effect. There is no timeout delay. PSMI can be cleared immediately once CMP goes high.

This monitor function allows the user to save working registers to avoid possible data loss due to the low supply or brown-out conditions. It also ensures that normal code execution does not resume until a safe supply level has been established.

The PSM does not operate correctly when using JTAG debug. It should be disabled in JTAG debug mode.

COMPARATOR

The ADuC7128/ADuC7129 integrate an uncommitted voltage comparator. The positive input is multiplexed with ADC2, and the negative input has two options: ADC3 or the internal reference. The output of the comparator can be configured to generate a system interrupt, can be routed directly to the programmable logic array, can start an ADC conversion, or can be on an external pin, CMP_{OUT}.



Figure 46. Comparator

Hysteresis

Figure 47 shows how the input offset voltage and hysteresis terms are defined. Input offset voltage (V_{OS}) is the difference between the center of the hysteresis range and the ground level. This can either be positive or negative. The hysteresis voltage (V_H) is $\frac{1}{2}$ the width of the hysteresis range.

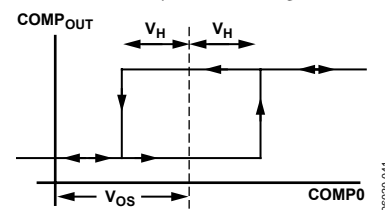

Figure 47. Comparator Hysteresis Transfer Function

ADuC7128/ADuC7129

Comparator Interface

The comparator interface consists of a 16-bit MMR, CMPCON, described in Table 57.

Table 57. CMPCON MMR Bit Designations

Bit	Value	Name	Description
15:11			Reserved.
10		COMPEN	Comparator Enable Bit. Set by user to enable the comparator. Cleared by user to disable the comparator. Note: A comparator interrupt is generated on the enable of the comparator. This should be cleared in the user software.
9:8	00 01 10 11	COMPIN	Comparator Negative Input Select Bits. AVDD/2. ADC3 input. $V_{REF} \times 0.6$. Reserved.
7:6	00 01 10 11	CMPOC	Comparator Output Configuration Bits. IRQ and PLA connections disabled. IRQ and PLA connections disabled. PLA connections enabled. IRQ connections enabled.
5		CMPOL	Comparator Output Logic State Bit. When low, the comparator output is high when the positive input (CMP0) is above the negative input (CMP1). When high, the comparator output is high when the positive input is below the negative input.
4:3	00 01 10 11	COMPRES	Response Time. 5 μ s response time typical for large signals (2.5 V differential). 17 μ s response time typical for small signals (0.65 mV differential). Reserved. Reserved. 3 μ s response time typical for any signal type.
2		CMPHYST	Comparator Hysteresis Bit. Set by user to have a hysteresis of about 7.5 mV. Cleared by user to have no hysteresis.
1		CMPORI	Comparator Output Rising Edge Interrupt. Set automatically when a rising edge occurs on the monitored voltage (CMP0). Cleared by user by writing a 1 to this bit.
0		CMPOFI	Comparator Output Falling Edge Interrupt. Set automatically when a falling edge occurs on the monitored voltage (CMP0). Cleared by user.

OSCILLATOR AND PLL—POWER CONTROL

The ADuC7128/ADuC7129 integrate a 32.768 kHz oscillator, a clock divider, and a PLL. The PLL locks onto a multiple (1275) of the internal oscillator to provide a stable 41.78 MHz clock for the system. The core can operate at this frequency, or at binary submultiples of it, to allow power saving. The default core clock is the PLL clock divided by 8 (CD = 3) or 5.2 MHz. The core clock frequency can be output on the ECLK pin as described in Figure 48. Note that when the ECLK pin is used to output the core clock, the output signal is not buffered and is not suitable for use as a clock source to an external device without an external buffer.

A power-down mode is available on the ADuC7128/ADuC7129.

The operating mode, clocking mode, and programmable clock divider are controlled via two MMRs, PLLCON (see Table 61) and POWCON (see Table 62). PLLCON controls operating mode of the clock system, and POWCON controls the core clock frequency and the power-down mode.

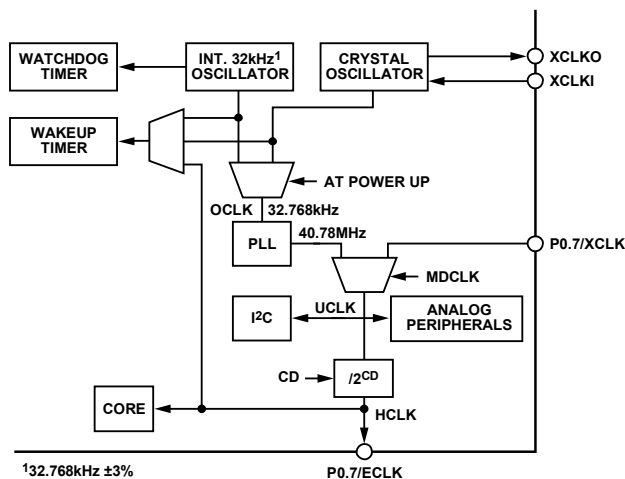

Figure 48. Clocking System

External Crystal Selection

To switch to an external crystal, use the following procedure:

1. Enable the Timer2 interrupt and configure it for a timeout period of >120 μ s.
2. Follow the write sequence to the PLLCON register, setting the MDCLK bits to 01 and clearing the OSEL bit.
3. Force the part into nap mode by following the correct write sequence to the POWCON register.
4. When the part is interrupted from nap mode by the Timer2 interrupt source, the clock source has switched to the external clock.

Example Source Code

```
T2LD = 5;
TCON = 0x480;
while ((T2VAL == t2val_old) || (T2VAL >
3)) //ensures timer value loaded
    IRQEN = 0x10;
//enable T2 interrupt
PLLKEY1 = 0xAA;
PLLCON = 0x01;
PLLKEY2 = 0x55;

POWKEY1 = 0x01;
POWCON = 0x27;
// Set Core into Nap mode
POWKEY2 = 0xF4;
```

In noisy environments, noise can couple to the external crystal pins, and PLL may lose lock momentarily. A PLL interrupt is provided in the interrupt controller. The core clock is immediately halted, and this interrupt is serviced only when the lock is restored.

In case of crystal loss, the watchdog timer should be used. During initialization, a test on the RSTSTA can determine if the reset came from the watchdog timer.

External Clock Selection

To switch to an external clock on P0.7, configure P0.7 in Mode 1. The external clock can be up to 44 MHz, providing the tolerance is 1%.

Example Source Code

```
T2LD = 5;
TCON = 0x480;
while ((T2VAL == t2val_old) || (T2VAL >
3)) //ensures timer value loaded
    IRQEN = 0x10;
//enable T2 interrupt
PLLKEY1 = 0xAA;
PLLCON = 0x03; //Select external clock
PLLKEY2 = 0x55;

POWKEY1 = 0x01;
POWCON = 0x27; // Set Core into Nap mode
POWKEY2 = 0xF4;
```

Power Control System

A choice of operating modes is available on the ADuC7128/ADuC7129. Table 58 describes what part of the ADuC7128/ADuC7129 is powered on in the different modes and indicates the power-up time. Table 59 gives some typical values of the total current consumption (analog + digital supply currents) in the different modes, depending on the clock divider bits. The ADC is turned off.

Note that these values also include current consumption of the regulator and other parts on the test board on which these values were measured.

ADuC7128/ADuC7129

Table 58. Operating Modes

Mode	Core	Peripherals	PLL	XTAL/T2/T3	XIRQ	Start-Up/Power-On Time
Active	On	On	On	On	On	130 ms at CD = 0
Pause		On	On	On	On	24 ns at CD = 0; 3.06 μs at CD = 7
Nap			On	On	On	24 ns at CD = 0; 3.06 μs at CD = 7
Sleep				On	On	1.58 ms
Stop					On	1.7 ms

Table 59. Typical Current Consumption at 25°C

PC[2:0]	Mode	CD = 0	CD = 1	CD = 2	CD = 3	CD = 4	CD = 5	CD = 6	CD = 7
000	Active	33.1	21.2	13.8	10	8.1	7.2	6.7	6.45
001	Pause	22.7	13.3	8.5	6.1	4.9	4.3	4	3.85
010	Nap	3.8	3.8	3.8	3.8	3.8	3.8	3.8	3.8
011	Sleep	0.4	0.4	0.4	0.4	0.4	0.4	0.4	0.4
100	Stop	0.4	0.4	0.4	0.4	0.4	0.4	0.4	0.4

MMRs and Keys

To prevent accidental programming, a certain sequence must be followed when writing in the PLLCON and POWCON registers (see Table 60).

PLLKEYx Register

Name	Address	Default Value	Access
PLLKEY1	0xFFFF0410	0x0000	W
PLLKEY2	0xFFFF0418	0x0000	W

PLLCON Register

Name	Address	Default Value	Access
PLLCON	0xFFFF0414	0x21	R/W

POWKEYx Register

Name	Address	Default Value	Access
POWKEY1	0xFFFF0404	0x0000	W
POWKEY2	0xFFFF040C	0x0000	W

POWCON Register

Name	Address	Default Value	Access
POWCON	0xFFFF0408	0x0003	R/W

Table 60. PLLCON and POWCON Write Sequence

PLLCON	POWCON
PLLKEY1 = 0xAA	POWKEY1 = 0x01
PLLCON = 0x01	POWCON = user value
PLLKEY2 = 0x55	POWKEY2 = 0xF4

Table 61. PLLCON MMR Bit Designations

Bit	Value	Name	Description
7:6			Reserved.
5		OSEL	32 kHz PLL Input Selection. Set by user to use the internal 32 kHz oscillator. Set by default. Cleared by user to use the external 32 kHz crystal.
4:2			Reserved.
1:0	00 01 10 11	MDCLK	Clocking Modes. Reserved. PLL. Default configuration. Reserved. External clock on P0.7 pin.

Table 62. POWCON MMR Bit Designations

Bit	Value	Name	Description
7			Reserved.
6:4	000 001 010 011 100 Others	PC	Operating Modes. Active mode. Pause mode. Nap. Sleep mode. IRQ0 to IRQ3 and Timer2 can wake up the ADuC7128/ADuC7129. Stop mode. Reserved.
3		RSVD	Reserved.
2:0	000 001 010 011 100 101 110 111	CD	CPU Clock Divider Bits. 41.779200 MHz. 20.889600 MHz. 10.444800 MHz. 5.222400 MHz. 2.611200 MHz. 1.305600 MHz. 654.800 kHz. 326.400 kHz.

DIGITAL PERIPHERALS

PWM GENERAL OVERVIEW

The ADuC7128/ADuC7129 integrate a six channel PWM interface. The PWM outputs can be configured to drive an H-bridge or can be used as standard PWM outputs. On power up, the PWM outputs default to H-bridge mode. This ensures that the motor is turned off by default. In standard PWM mode, the outputs are arranged as three pairs of PWM pins. Users have control over the period of each pair of outputs and over the duty cycle of each individual output.

Table 63. PWM MMRs

Name	Description
PWMCON1	PWM Control
PWM1COM1	Compare Register 1 for PWM Outputs 1 and 2
PWM1COM2	Compare Register 2 for PWM Outputs 1 and 2
PWM1COM3	Compare Register 3 for PWM Outputs 1 and 2
PWM1LEN	Frequency Control for PWM Outputs 1 and 2
PWM2COM1	Compare Register 1 for PWM Outputs 3 and 4
PWM2COM2	Compare Register 2 for PWM Outputs 3 and 4
PWM2COM3	Compare Register 3 for PWM Outputs 3 and 4
PWM2LEN	Frequency Control for PWM Outputs 3 and 4
PWM3COM1	Compare Register 1 for PWM Outputs 5 and 6
PWM3COM2	Compare Register 2 for PWM Outputs 5 and 6
PWM3COM3	Compare Register 3 for PWM Outputs 5 and 6
PWM3LEN	Frequency Control for PWM Outputs 5 and 6
PWMCON2	PWM Convert Start Control
PWMICLR	PWM Interrupt Clear

In all modes, the PWMxCOMx MMRs controls the point at which the PWM outputs change state. An example of the first pair of PWM outputs (PWM1 and PWM2) is shown in Figure 49.

Table 64. PWMCON1 MMR Bit Designations

Bit	Name	Description
14	SYNC	Enables PWM Synchronization. Set to 1 by the user so that all PWM counters are reset on the next clock edge after the detection of a high-to-low transition on the SYNC pin. Cleared by user to ignore transitions on the SYNC pin.
13	PWM6INV	Set to 1 by the user to invert PWM6. Cleared by user to use PWM6 in normal mode.
12	PWM4NV	Set to 1 by the user to invert PWM4. Cleared by user to use PWM4 in normal mode.
11	PWM2INV	Set to 1 by the user to invert PWM2. Cleared by user to use PWM2 in normal mode.
10	PWMTRIP	Set to 1 by the user to enable PWM trip interrupt. When the PWMTRIP input is low, the PWMEN bit is cleared and an interrupt is generated. Cleared by user to disable the PWMTRIP interrupt.
9	ENA	If HOFF = 0 and HMODE = 1. Set to 1 by the user to enable PWM outputs. Cleared by user to disable PWM outputs. If HOFF = 1 and HMODE = 1, see Table 65. If not in H-Bridge mode, this bit has no effect.
8	PWMCP2	PWM Clock Prescaler Bits.
7	PWMCP1	Sets UCLK divider.

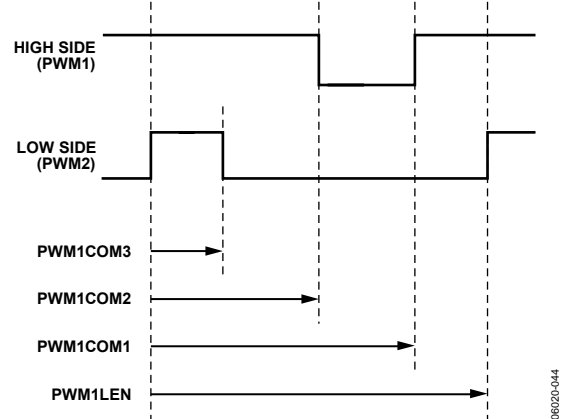

Figure 49. PWM Timing

The PWM clock is selectable via PWMCON1 with one of the following values: UCLK/2, 4, 8, 16, 32, 64, 128, or 256. The length of a PWM period is defined by PWMxLEN.

The PWM waveforms are set by the count value of the 16-bit timer and the compare registers contents as shown with the PWM1 and PWM2 waveforms above.

The low-side waveform, PWM2, goes high when the timer count reaches PWM1LEN, and it goes low when the timer count reaches the value held in PWM1COM3 or when the high-side waveform PWM1 goes low.

The high-side waveform, PWM1, goes high when the timer count reaches the value held in PWM1COM1, and it goes low when the timer count reaches the value held in PWM1COM2.

ADuC7128/ADuC7129

Bit	Name	Description
6	PWMCPO	2. 4. 8. 16. 32. 64. 128. 256.
5	POINV	Set to 1 by the user to invert all PWM outputs. Cleared by user to use PWM outputs as normal.
4	HOFF	High Side Off. Set to 1 by the user to force PWM1 and PWM3 outputs high. This also forces PWM2 and PWM4 low. Cleared by user to use the PWM outputs as normal.
3	LCOMP	Load Compare Registers. Set to 1 by the user to load the internal compare registers with the values in PWMxCOMx on the next transition of the PWM timer from 0x00 to 0x01. Cleared by user to use the values previously stored in the internal compare registers.
2	DIR	Direction Control. Set to 1 by the user to enable PWM1 and PWM2 as the output signals while PWM3 and PWM4 are held low. Cleared by user to enable PWM3 and PWM4 as the output signals while PWM1 and PWM2 are held low.
1	HMODE	Enables H-bridge mode. Set to 1 by the user to enable H-Bridge mode and Bit 1 to Bit 5 of PWMCON1. Cleared by user to operate the PWMs in standard mode.
0	PWMEN	Set to 1 by the user to enable all PWM outputs. Cleared by user to disable all PWM outputs.

In H-bridge mode, HMODE = 1. See Table 65 to determine the PWM outputs.

Table 65. PWM Output Selection

PWMCON1 MMR				PWM Outputs			
ENA	HOFF	POINV	DIR	PWM1	PWM2	PWMR3	PWM4
0	0	x	x	1	1	1	1
x	1	x	x	1	0	1	0
1	0	0	0	0	0	HS ¹	LS ¹
1	0	0	1	HS ¹	LS ¹	0	0
1	0	1	0	HS ¹	LS ¹	1	1
1	0	1	1	1	1	HS ¹	LS ¹

¹ HS = high side, LS = low side.

On power-up, PWMCON1 defaults to 0x12 (HOFF = 1 and HMODE = 1). All GPIO pins associated with the PWM are configured in PWM mode by default (see Table 66).

Table 66. Compare Register

Name	Address	Default Value	Access
PWM1COM1	0xFFFF0F84	0x00	R/W
PWM1COM2	0xFFFF0F88	0x00	R/W
PWM1COM3	0xFFFF0F8C	0x00	R/W
PWM2COM1	0xFFFF0F94	0x00	R/W
PWM2COM2	0xFFFF0F98	0x00	R/W
PWM2COM3	0xFFFF0F9C	0x00	R/W
PWM3COM1	0xFFFF0FA4	0x00	R/W
PWM3COM2	0xFFFF0FA8	0x00	R/W
PWM3COM3	0xFFFF0FAC	0x00	R/W

The PWM trip interrupt can be cleared by writing any value to the PWMICLR MMR. Note that when using the PWM trip interrupt, the PWM interrupt should be cleared before exiting the ISR. This prevents generation of multiple interrupts.

PWM CONVERT START CONTROL

The PWM can be configured to generate an ADC convert start signal after the active low side signal goes high. There is a programmable delay between when the low-side signal goes high and the convert start signal is generated.

This is controlled via the PWMCON2 MMR. If the delay selected is higher than the width of the PWM pulse, the interrupt remains low.

Table 67. PWMCON2 MMR Bit Designations

Bit	Value	Name	Description
7		CSEN	Set to 1 by the user to enable the PWM to generate a convert start signal. Cleared by user to disable the PWM convert start signal.
6:4		RSVD	Reserved. This bit should be set to 0 by the user.
3:0		CSD3 CSD2 CSD1 CSD0	Convert Start Delay. Delays the convert start signal by a number of clock pulses.
	0000		4 clock pulses.
	0001		8 clock pulses.
	0010		12 clock pulses.
	0011		16 clock pulses.
	0100		20 clock pulses.
	0101		24 clock pulses.
	0110		28 clock pulses.
	0111		32 clock pulses.
	1000		36 clock pulses.
	1001		40 clock pulses.
	1010		44 clock pulses.
	1011		48 clock pulses.
	1100		52 clock pulses.
	1101		56 clock pulses.
	1110		60 clock pulses.
	1111		64 clock pulses.

When calculating the time from the convert start delay to the start of an ADC conversion, the user needs to take account of internal delays. The example below shows the case for a delay of four clocks. One additional clock is required to pass the convert start signal to the ADC logic. Once the ADC logic receives the convert start signal an ADC conversion begins on the next ADC clock edge (see Figure 50).



Figure 50. ADC Conversion

Quadrature Encoder

A quadrature encoder is used to determine both the speed and direction of a rotating shaft. In its most common form, there are two digital outputs, S1 and S2. As the shaft rotates, both S1 and S2 toggle; however, they are 90° out of phase. The leading output determines the direction of rotation. The time between each transition indicates the speed of rotation.

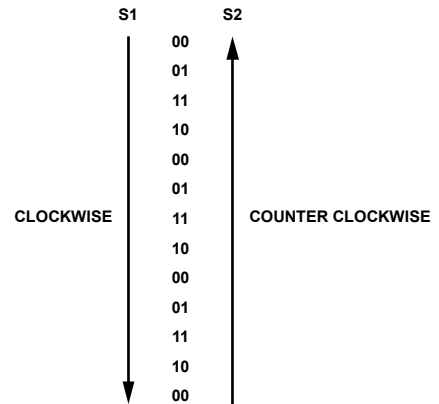

Figure 51. Quadrature Encoder Input Values

The quadrature encoder takes the incremental input shown in Figure 51 and increments or decrements a counter depending on the direction and speed of the rotating shaft.

On the ADuC7128/ADuC7129, the internal counter is clocked on the rising edge of the S1 input, and the S2 input indicates the direction of rotation/count. The counter increments when S2 is high and decrements when it is low.

In addition, if the software has prior knowledge of the direction of rotation, one input can be ignored (S2) and the other can act as a clock (S1).

For additional flexibility, all inputs can be internally inverted prior to use.

The quadrature encoder operates asynchronously from the system clock.

Input Filtering

Filtering can be applied to the S1 input by setting the FILTEN bit in QENCON. S1 normally acts as the clock to the counter; however, the filter can be used to ignore positive edges on S1 unless there has been a high or a low pulse on S2 between two positive edges on S1 (see Figure 52).

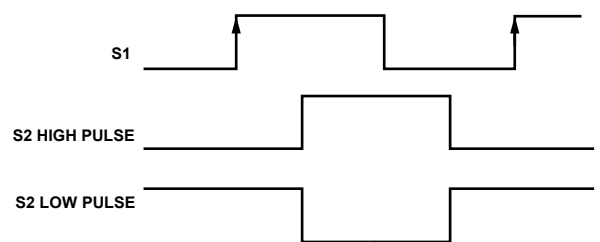

Figure 52. S1 Input Filtering

ADuC7128/ADuC7129

Table 68. QENCON MMR Bit Designations

Bit	Name	Description
15:11	RSVD	Reserved.
10	FILTEN	Set to 1 by the user to enable filtering on the S1 pin. Cleared by user to disable filtering on the S1 pin.
9	RSVD	Reserved. This bit should be set to 0 by the user.
8	S2INV	Set to 1 by the user to invert the S2 input. Cleared by user to use the S2 input as normal. If the DIRCON bit is set, then S2INV controls the direction of the counter. In this case, set to 1 by the user to operate the counter in increment mode. Cleared by user to operate the counter in decrement mode.
7	S1INV	Set to 1 by the user to invert the S1 input. Cleared by user to use the S1 input as normal.
6	DIRCON	Direction Control. Set to 1 by the user to enable S1 as the input to the counter clock. The direction of the counter is controlled via the S2INV bit. Cleared by user to operate in normal mode.
5	S1IRQEN	Set to 1 by the user to generate an IRQ when a low-to-high transition is detected on S1. Cleared by the user to disable the interrupt.
4	RSVD	This bit should be set to 0 by the user.
3	UIRQEN	Underflow IRQ Enable. Set to 1 by the user to generate an interrupt if QENVAL underflows. Cleared by the user to disable the interrupt.
2	OIRQEN	Overflow IRQ Enable. Set to 1 by the user to generate an interrupt if QENVAL overflows. Cleared by user to disable the interrupt.
1	RSVD	This bit should be set to 0 by the user.
0	ENQEN	Quadrature Encoder Enable. Set to 1 by the user to enable the quadrature encoder. Cleared by user to disable the quadrature encoder.

Table 69. QENSTA MMR Bit Designations

Bit	Name	Description
7:5	RSVD	Reserved.
4	S1EDGE	S1 Rising Edge. This bit is set automatically on a rising edge of S1. Cleared by reading QENSTA.
3	RSVD	Reserved.
2	UNDER	Underflow Flag. This bit is set automatically if an underflow occurs. Cleared by reading QENSTA.
1	OVER	This bit is set automatically if an overflow has occurred. Cleared by reading QENSTA.
0	DIR	Direction of the Counter. Set to 1 by hardware to indicate that the counter is incrementing. Set to 0 by hardware to indicate that the counter is decrementing.

QENDAT Register

Name	Address	Default Value	Access
QENDAT	0xFFFFF0F8	0Xffff	R/W

The QENDAT register holds the maximum value allowed for the QENVAL register. If the QENVAL register increments past the value in this register, an overflow condition occurs. When an overflow occurs, the QENVAL register is reset to 0x0000. When the QENVAL register decrements past zero during an underflow, it is loaded with the value in QENDAT.

QENVAL Register

Name	Address	Default Value	Access
QENVAL	0xFFFFF0FC	0x0000	R/W

The QENVAL register contains the current value of the quadrature encoder counter.

QENCLR Register

Name	Address	Default Value	Access
QENCLR	0xFFFF0F14	0x00000000	R/W

Writing any value to the QENCLR register clears the QENVAL register to 0x0000. The bits in this register are undefined.

QENSET Register

Name	Address	Default Value	Access
QENSET	0xFFFF0F18	0x00000000	R/W

Writing any value to the QENSET register loads the QENVAL register with the value in QENDAT. The bits in this register are undefined.

Note that the interrupt conditions are ORed together to form one interrupt to the interrupt controller. The interrupt service routine should check the QENSTA register to find out the cause of the interrupt.

- The S1 and S2 inputs appear as the QENS1 and QENS2 inputs in the GPIO list.
- The motor speed can be measured by using the capture facility in Timer0 or Timer1.
- An overflow of either timer can be checked by using an ISR or by checking IRQSIG.

The counter with the quadrature encoder is gray encoded to ensure reliable data transfer across clock boundaries. When an underflow or overflow occur, the count value does not jump to the other end of the scale; instead, the direction of count changes. When this happens, the value in QENDAT is subtracted from the value derived from the gray count.

When the value in QENDAT changes, the value read back from QENVAL changes. However, the gray encoded value does not change. This only occurs after an underflow or overflow. If the value in QENDAT changes, there must be a write to QENSET or QENCLR to ensure a valid number is read back from QENVAL.

GENERAL-PURPOSE I/O

The ADuC7128/ADuC7129 provide 40 general-purpose, bidirectional I/O (GPIO) pins. All I/O pins are 5 V tolerant, meaning that the GPIOs support an input voltage of 5 V. In general, many of the GPIO pins have multiple functions (see Table 70). By default, the GPIO pins are configured in GPIO mode.

All GPIO pins have an internal pull-up resistor (of about 100 kΩ) and their drive capability is 1.6 mA. Note that a maximum of 20 GPIO can drive 1.6 mA at the same time. The following GPIOs have programmable pull-up: P0.0, P0.4, P0.5, P0.6, P0.7, and the eight GPIOs of P1.

The 40 GPIOs are grouped in five ports: Port 0 to Port 4. Each port is controlled by four or five MMRs, with x representing the port number.

GPxCON Register

Name	Address	Default Value	Access
GP0CON	0xFFFF0D00	0x00000000	R/W
GP1CON	0xFFFF0D04	0x00000000	R/W
GP2CON	0xFFFF0D08	0x00000000	R/W
GP3CON	0xFFFF0D0C	0x11111111	R/W
GP4CON	0xFFFF0D10	0x00000000	R/W

Note that the kernel changes P0.6 from its default configuration at reset ($\overline{\text{MRST}}$) to GPIO mode. If $\overline{\text{MRST}}$ is used for external circuitry, an external pull-up resistor should be used to ensure that the level on P0.6 does not drop when the kernel switches mode. Otherwise, P0.6 goes low for the reset period. For example, if $\overline{\text{MRST}}$ is required for power-down, it can be reconfigured in GP0CON MMR.

The input level of any GPIO can be read at any time in the GPxDAT MMR, even when the pin is configured in a mode other than GPIO. The PLA input is always active.

When the ADuC7128/ADuC7129 enter a power-saving mode, the GPIO pins retain their state.

GPxCON is the Port x control register, and it selects the function of each pin of Port x, as described in Table 70.

ADuC7128/ADuC7129

Table 70. GPIO Pin Function Designations

Port	Pin	Configuration			
		00	01	10	11
0	P0.0	GPIO	CMP	MS0	PLAI[7]
	P0.1 ¹	GPIO		BLE	-
	P0.2 ¹	GPIO		BHE	
	P0.3	GPIO	TRST	A16	ADC _{BUSY}
	P0.4	GPIO/IRQ0	CONVST	MS1	PLAO[1]
	P0.5	GPIO/IRQ1	ADC _{BUSY}	PLM_COMP	PLAO[2]
	P0.6	GPIO/T1	MRST	AE	PLAO[3]
	P0.7	GPIO	ECLK/XCLK ²	SIN0	PLAO[4]
1	P1.0	GPIO/T1	SIN0	SCL0	PLAI[0]
	P1.1	GPIO	SOUT0	SDA0	PLAI[1]
	P1.2	GPIO	RTS0	SCL1	PLAI[2]
	P1.3	GPIO	CTS0	SDA1	PLAI[3]
	P1.4	GPIO/IRQ2	RI0	CLK	PLAI[4]
	P1.5	GPIO/IRQ3	DCD0	MISO	PLAI[5]
	P1.6	GPIO	DSR0	MOSI	PLAI[6]
	P1.7	GPIO	DTR0	CSL	PLAO[0]
2	P2.0	GPIO	SYNC	SOUT	PLAO[5]
	P2.1 ¹	GPIO		WS	PLAO[6]
	P2.2 ¹	GPIO	RTS1	RS	PLAO[7]
	P2.3 ¹	GPIO	CTS1	AE	
	P2.4 ¹	GPIO	RI1	MS0	
	P2.5 ¹	GPIO	DCD1	MS1	
	P2.6 ¹	GPIO	DSR1	MS2	
	P2.7 ¹	GPIO	DTR1	MS3	
3	P3.0	GPIO	PWM1	AD0	PLAI[8]
	P3.1	GPIO	PWM2	AD1	PLAI[9]
	P3.2	GPIO	PWM3	AD2	PLAI[10]
	P3.3	GPIO	PWM4	AD3	PLAI[11]
	P3.4	GPIO	PWM5	AD4	PLAI[12]
	P3.5	GPIO	PWM6	AD5	PLAI[13]
	P3.6 ¹	GPIO	PWM1	AD6	PLAI[14]
	P3.7 ¹	GPIO	PWM3	AD7	PLAI[15]
4	P4.0	GPIO	QENS1	AD8	PLAO[8]
	P4.1	GPIO	QENS2	AD9	PLAO[9]
	P4.2	GPIO	RSVD	AD10	PLAO[10]
	P4.3	GPIO	Trip (Shutdown)	AD11	PLAO[11]
	P4.4	GPIO	PLMIN	AD12	PLAO[12]
	P4.5	GPIO	PLMOUT	AD13	PLAO[13]
	P4.6	GPIO	SIN1	AD14	PLAO[14]
	P4.7	GPIO	SOUT1	AD15	PLAO[15]

¹ Available only on the 80-lead ADuC7129.

² When configured in Mode 1, PO.7 is ECLK by default, or core clock output. To configure it as a clock output, the MDCLK bits in PLLCON must be set to 11.

Table 71. GPxCON MMR Bit Designations

Bit	Description
31:30	Reserved
29:28	Select function of Px.7 pin
27:26	Reserved
25:24	Select function of Px.6 pin
23:22	Reserved
21:20	Select function of Px.5 pin
19:18	Reserved
17:16	Select function of Px.4 pin
15:14	Reserved
13:12	Select function of Px.3 pin
11:10	Reserved
9:8	Select function of Px.2 pin
7:6	Reserved
5:4	Select function of Px.1 pin
3:2	Reserved
1:0	Select function of Px.0 pin

GPxPAR Register

Name	Address	Default Value	Access
GP0PAR	0xFFFF0D2C	0x20000000	R/W
GP1PAR	0xFFFF0D3C	0x00000000	R/W
GP3PAR	0xFFFF0D5C	0x00222222	R/W
GP4PAR	0xFFFF0D6C	0x00000000	R/W

GPxPAR programs the parameters for Port 0, Port 1, Port 3, and Port 4. Note that the GPxDAT MMR must always be written after changing the GPxPAR MMR.

Table 72. GPxPAR MMR Bit Designations

Bit	Description
31:29	Reserved
28	Pull-up disable Px.7 pin
27:25	Reserved
24	Pull-up disable Px.6 pin
23:21	Reserved
20	Pull-up disable Px.5 pin
19:17	Reserved
16	Pull-up disable Px.4 pin
15:13	Reserved
12	Pull-up disable Px.3 pin
11:9	Reserved
8	Pull-up disable Px.2 pin
7:5	Reserved
4	Pull-up disable Px.1 pin
3:1	Reserved
0	Pull-up disable Px.0 pin

GPxDAT Register

Name	Address	Default Value	Access
GP0DAT	0xFFFF0D20	0x000000XX	R/W
GP1DAT	0xFFFF0D30	0x000000XX	R/W
GP2DAT	0xFFFF0D40	0x000000XX	R/W
GP3DAT	0xFFFF0D50	0x000000XX	R/W
GP4DAT	0xFFFF0D60	0x000000XX	R/W

GPxDAT is a Port x configuration and data register. It configures the direction of the GPIO pins of Port x, sets the output value for the pins configured as output, and receives and stores the input value of the pins configured as input.

Table 73. GPxDAT MMR Bit Designations

Bit	Description
31:24	Direction of the Data. Set to 1 by user to configure the GPIO pins as outputs. Cleared to 0 by user to configure the GPIO pins as inputs.
23:16	Port x Data Output.
15:8	Reflect the state of Port x pins at reset (read only).
7:0	Port x Data Input (Read Only).

GPxSET Register

Name	Address	Default Value	Access
GP0SET	0xFFFF0D24	0x000000XX	W
GP1SET	0xFFFF0D34	0x000000XX	W
GP2SET	0xFFFF0D44	0x000000XX	W
GP3SET	0xFFFF0D54	0x000000XX	W
GP4SET	0xFFFF0D64	0x000000XX	W

GPxSET is a data set Port x register.

Table 74. GPxSET MMR Bit Designations

Bit	Description
31:24	Reserved.
23:16	Data Port x Set Bit. Set to 1 by user to set bit on Port x; also sets the corresponding bit in the GPxDAT MMR. Cleared to 0 by user; does not affect the data out.
15:0	Reserved.

GPxCLR Register

Name	Address	Default Value	Access
GP0CLR	0xFFFF0D28	0x000000XX	W
GP1CLR	0xFFFF0D38	0x000000XX	W
GP2CLR	0xFFFF0D48	0x000000XX	W
GP3CLR	0xFFFF0D58	0x000000XX	W
GP4CLR	0xFFFF0D68	0x000000XX	W

GPxCLR is a data clear Port x register.

Table 75. GPxCLR MMR Bit Designations

Bit	Description
31:24	Reserved.
23:16	Data Port x Clear Bit. Set to 1 by user to clear bit on Port x; also clears the corresponding bit in the GPxDAT MMR. Cleared to 0 by user; does not affect the data out.
15:0	Reserved.

SERIAL PORT MUX

The serial port mux multiplexes the serial port peripherals (two I²Cs, an SPI, and two UARTs) and the programmable logic array (PLA) to a set of 10 GPIO pins. Each pin must be configured to its specific I/O function as described in Table 76.

Table 76. SPM Configuration

Pin	GPIO (00)	UART (01)	UART/I2C/SPI (10)	PLA (11)
SPM0	P1.0	SIN0	I2C0SCL	PLAI[0]
SPM1	P1.1	SOUT0	I2C0SDA	PLAI[1]
SPM2	P1.2	RTS0	I2C1SCL	PLAI[2]
SPM3	P1.3	CTS0	I2C1SDA	PLAI[3]
SPM4	P1.4	RI0	SPICLK	PLAI[4]
SPM5	P1.5	DCD0	SPIMISO	PLAI[5]
SPM6	P1.6	DSR0	SPIMOSI	PLAI[6]
SPM7	P1.7	DTR0	SPICSL	PLAO[0]
SPM8	P0.7	ECLK	SIN0	PLAO[4]
SPM9	P2.0 ¹	PWMSYNC	SOUT0	PLAO[5]
SPM10	P2.2 ¹	RTS1	RS	PLAO[7]
SPM11	P2.3 ¹	CTS1	AE	
SPM12	P2.4 ¹	RI1	MS0	
SPM13	P2.5 ¹	DCD1	MS1	
SPM14	P2.6 ¹	DSR1	MS2	
SPM15	P2.7 ¹	DTR1	MS3	
SPM16	P4.6	SIN1	AD14	PLAO[14]
SPM17	P4.7	SOUT1	AD15	PLAO[15]

¹ Available only on the 80-lead ADuC7129.

Table 76 details the mode for each of the SPMUX GPIO pins. This configuration has to be performed via the GP0CON, GP1CON and GP2CON MMRs. By default these pins are configured as GPIOs.

UART SERIAL INTERFACE

The ADuC7128/ADuC7129 contain two identical UART blocks. Although only UART0 is described here, UART1 functions in exactly the same way.

The UART peripheral is a full-duplex universal asynchronous receiver/transmitter, fully compatible with the 16450 serial port standard.

The UART performs serial-to-parallel conversion on data characters received from a peripheral device or a modem, and parallel-to-serial conversion on data characters received from the CPU. The UART includes a fractional divider for baud rate generation and has a network-addressable mode. The UART function is made available on 10 pins of the ADuC7128/ADuC7129 (see Table 77).

ADuC7128/ADuC7129

Table 77. UART Signal Descriptions

Pin	Signal	Description
SPM0 (Mode 1)	SIN0	Serial Receive Data.
SPM1 (Mode 1)	SOUT0	Serial Transmit Data.
SPM2 (Mode 1)	RTS0	Request to Send.
SPM3 (Mode 1)	CTS0	Clear to Send.
SPM4 (Mode 1)	RI0	Ring Indicator.
SPM5 (Mode 1)	DCDO	Data Carrier Detect.
SPM6 (Mode 1)	DSR0	Data Set Ready.
SPM7 (Mode 1)	DTR0	Data Terminal Ready.
SPM8 (Mode 2)	SIN0	Serial Receive Data.
SPM9 (Mode 2)	SOUT0	Serial Transmit Data.

The serial communication adopts an asynchronous protocol that supports various word-length, stop-bits, and parity generation options selectable in the configuration register.

Baud Rate Generation

There are two ways of generating the UART baud rate: normal 450 UART baud rate generation and using the fractional divider.

Normal 450 UART Baud Rate Generation

The baud rate is a divided version of the core clock, using the value in COM0DIV0 and COM0DIV1 MMRs (16-bit value, DL).

$$Baud\ Rate = \frac{41.78\ MHz}{2^{CD} \times 16 \times 2 \times DL}$$

Table 78 gives some common baud rate values.

Table 78. Baud Rate Using the Normal Baud Rate Generator

Baud Rate	CD	DL	Actual Baud Rate	% Error
9600	0	0x88	9600	0%
19,200	0	0x44	19,200	0%
115,200	0	0x0B	118,691	3%
9600	3	0x11	9600	0%
19,200	3	0x08	20,400	6.25%
115,200	3	0x01	163,200	41.67%

Using the Fractional Divider

The fractional divider combined with the normal baud rate generator allows the generating of a wider range of more accurate baud rates.

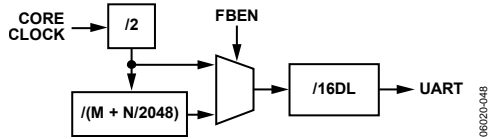

Figure 53. Baud Rate Generation Options

Calculation of the baud rate using fractional divider is as follows:

$$Baud\ Rate = \frac{41.78\ MHz}{2^{CD} \times 16 \times DL \times 2 \times (M + \frac{N}{2048})}$$

$$M + \frac{N}{2048} = \frac{41.78\ MHz}{Baud\ Rate \times 2^{CD} \times 16 \times DL \times 2}$$

For example, generation of 19,200 bauds with CD bits = 3. Table 78 gives DL = 0x08.

$$M + \frac{N}{2048} = \frac{41.78\ MHz}{19200 \times 2^3 \times 16 \times 8 \times 2}$$

$$M + \frac{N}{2048} = 1.06$$

where:

$$M = 1$$

$$N = 0.06 \times 2048 = 128$$

$$Baud\ Rate = \frac{41.78\ MHz}{2^3 \times 16 \times 8 \times 2 \times \left(\frac{128}{2048}\right)}$$

where:

$$Baud\ Rate = 19,200\ bps.$$

Error = 0% compared to 6.25% with the normal baud rate generator.

UART Register Definitions

The UART interface consists of 12 registers.

Table 79. UART MMRs

Register	Description
COMxTX	8-Bit Transmit Register.
COMxRX	8-Bit Receive Register.
COMxDIV0	Divisor Latch (Low Byte).
COMxTX, COMxRX, and COMxDIV0	Share The Same Address Location. COMxTX and COMxRX can be accessed when Bit 7 in COMxCON0 register is cleared. COMxDIV0 can be accessed when Bit 7 of COMxCON0 is set.
COMxDIV1	Divisor Latch (High Byte).
COMxCON0	Line Control Register.
COMxSTA0	Line Status Register.
COMxIEN0	Interrupt Enable Register.
COMxIID0	Interrupt Identification Register.
COMxCON1	Modem Control Register.
COMxSTA1	Modem Status Register.
COMxDIV2	16-Bit Fractional Baud Divide Register.
COMxSCR	8-Bit Scratch Register Used for Temporary Storage. Also used in network addressable UART mode.

Table 80. COMxCON0 MMR Bit Designations

Bit	Value	Name	Description
7		DLAB	Divisor Latch Access. Set by user to enable access to COMxDIV0 and COMxDIV1 registers. Cleared by user to disable access to COMxDIV0 and COMxDIV1 and enable access to COMxRX and COMxTX.
6		BRK	Set Break. Set by user to force SOUT to 0. Cleared to operate in normal mode.
5		SP	Stick Parity. Set by user to force parity to defined values. 1 if EPS = 1 and PEN = 1 0 if EPS = 0 and PEN = 1
4		EPS	Even Parity Select Bit. Set for even parity. Cleared for odd parity.
3		PEN	Parity Enable Bit. Set by user to transmit and check the parity bit. Cleared by user for no parity transmission or checking.
2		STOP	Stop Bit. Set by user to transmit 1.5 stop bits if the word length is 5 bits or 2 stop bits if the word length is 6 bits, 7 bits, or 8 bits. The receiver checks the first stop bit only, regardless of the number of stop bits selected. Cleared by user to generate 1 stop bit in the transmitted data.
1:0	00 01 10 11	WLS	Word Length Select. 5 bits. 6 bits. 7 bits. 8 bits.

Table 81. COMxSTA0 MMR Bit Designations

Bit	Name	Description
7	RSVD	Reserved.
6	TEMT	COMxTX Empty Status Bit. Set automatically if COMxTX is empty. Cleared automatically when writing to COMxTX.
5	THRE	COMxTX and COMxRX Empty. Set automatically if COMxTX and COMxRX are empty. Cleared automatically when one of the registers receives data.
4	BI	Break Error. Set when SIN is held low for more than the maximum word length. Cleared automatically.
3	FE	Framing Error. Set when stop bit invalid. Cleared automatically.
2	PE	Parity Error. Set when a parity error occurs. Cleared automatically.
1	OE	Overrun Error. Set automatically if data is overwritten before it is read. Cleared automatically.
0	DR	Data Ready. Set automatically when COMxRX is full. Cleared by reading COMxRX.

ADuC7128/ADuC7129

Table 82. COMxIEN0 MMR Bit Designations

Bit	Name	Description
7:4	RSVD	Reserved.
3	EDSSI	Modem Status Interrupt Enable Bit. Set by user to enable generation of an interrupt if any of COMxSTA1[3:0] are set. Cleared by user.
2	ELSI	RX Status Interrupt Enable Bit. Set by user to enable generation of an interrupt if any of COMxSTA0[3:1] are set. Cleared by user.
1	ETBEI	Enable Transmit Buffer Empty Interrupt. Set by user to enable interrupt when buffer is empty during a transmission. Cleared by user.
0	ERBFI	Enable Receive Buffer Full Interrupt. Set by user to enable interrupt when buffer is full during a reception. Cleared by user.

Table 83. COMxIID0 MMR Bit Designations

Bit 2:1 Status Bits	Bit 0 NINT	Priority	Definition	Clearing Operation
00	1		No Interrupt.	
11	0	1	Receive Line Status Interrupt.	Read COMxSTA0.
10	0	2	Receive Buffer Full Interrupt.	Read COMxRX.
01	0	3	Transmit Buffer Empty Interrupt.	Write data to COMxTX or read COMxIID0.
00	0	4	Modem Status Interrupt.	Read COMxSTA1.

Table 84. COMxCON1 MMR Bit Designations

Bit	Name	Description
7:5	RSVD	Reserved.
4	LOOPBACK	Loop Back. Set by user to enable loop-back mode. In loop-back mode, the SOUT is forced high. In addition, the modem signals are directly connected to the status inputs (RTS to CTS, DTR to DSR, OUT1 to RI, and OUT2 to DCD).
3		Reserved.
2		Reserved.
1	RTS	Request to Send. Set by user to force the RTS output to 0. Cleared by user to force the RTS output to 1.
0	DTR	Data Terminal Ready. Set by user to force the DTR output to 0. Cleared by user to force the DTR output to 1.

Table 85. COMxSTA1 MMR Bit Designations

Bit	Name	Description
7	DCD	Data Carrier Detect.
6	RI	Ring Indicator.
5	DSR	Data Set Ready.
4	CTS	Clear to Send.
3	DDCD	Delta Data Carrier Detect. Set automatically if DCD changed state since COMxSTA1 last read. Cleared automatically by reading COMxSTA1.
2	TERI	Trailing Edge Ring Indicator. Set if NRI changed from 0 to 1 since COMxSTA1 last read. Cleared automatically by reading COMxSTA1.
1	DDSR	Delta Data Set Ready. Set automatically if DSR changed state since COMxSTA1 last read. Cleared automatically by reading COMxSTA1.
0	DCTS	Delta Clear to Send. Set automatically if CTS changed state since COMxSTA1 last read. Cleared automatically by reading COMxSTA1.

Table 86. COMxDIV2 MMR Bit Designations

Bit	Name	Description
15	FBEN	Fractional Baud Rate Generator Enable Bit. Set by user to enable the fractional baud rate generator. Cleared by user to generate baud rate using the standard 450 UART baud rate generator.
14:13	RSVD	Reserved.
12:11	FBM[1 to 0]	M, if FBM = 0, M = 4 (see the Using the Fractional Divider section).
10:0	FBN[10 to 0]	N (see the Using the Fractional Divider section).

Network Addressable UART Mode

This mode allows connecting the MicroConverter on a 256-node serial network, either as a hardware single master or via software in a multimaster network. Bit 7 of COMxIEN1 (ENAM bit) must be set to enable UART in network-addressable mode.

Note that there is no parity check in this mode. The parity bit is used for address.

Network Addressable UART Register Definitions

Four additional registers, COMxIEN0, COMxIEN1, COMxIID1, and COMxADR are used only in network addressable UART mode.

In network address mode, the least significant bit of the COMxIEN1 register is the transmitted network address control bit. If set to 1, the device is transmitting an address. If cleared to 0, the device is transmitting data. For example, the following master-based code transmits the slave address followed by the data:

```
COM0IEN1 = 0xE7;           //Setting ENAM, E9BT, E9BR, ETD, NABP
COM0TX = 0xA0;            // Slave address is 0xA0
while(!(0x020==(COM0STA0 & 0x020))){} // wait for adr tx to finish.
COM0IEN1 = 0xE6;         // Clear NAB bit to indicate Data is coming
COM0TX = 0x55;           // Tx data to slave: 0x55
```

Table 87. COMxIEN1 MMR Bit Designations

Bit	Name	Description
7	ENAM	Network Address Mode Enable Bit. Set by user to enable network address mode. Cleared by user to disable network address mode.
6	E9BT	9-Bit Transmit Enable Bit. Set by user to enable 9-bit transmit. ENAM must be set. Cleared by user to disable 9-bit transmit.
5	E9BR	9-Bit Receive Enable Bit. Set by user to enable 9-bit receive. ENAM must be set. Cleared by user to disable 9-bit receive.
4	ENI	Network Interrupt Enable Bit.
3	E9BD	Word Length. Set for 9-bit data. E9BT has to be cleared. Cleared for 8-bit data.
2	ETD	Transmitter Pin Driver Enable Bit. Set by user to enable SOUT as an output in slave mode or multimaster mode. Cleared by user; SOUT is three-state.
1	NABP	Network Address Bit, Interrupt Polarity Bit.
0	NAB	Network Address Bit. Set by user to transmit the slave's address. Cleared by user to transmit data.

Table 88. COMxIID1 MMR Bit Designations

Bit 3:1 Status Bits	Bit 0 NINT	Priority	Definition	Clearing Operation
000	1		No Interrupt.	
110	0	2	Matching Network Address.	Read COMxRX.
101	0	3	Address Transmitted, Buffer Empty.	Write data to COMxTX or read COMxIID0.
011	0	1	Receive Line Status Interrupt.	Read COMxSTA0.
010	0	2	Receive Buffer Full Interrupt.	Read COMxRX.
001	0	3	Transmit Buffer Empty Interrupt.	Write data to COMxTX or read COMxIID0.
000	0	4	Modem Status Interrupt.	Read COMxSTA1 register.

Note that to receive a network address interrupt, the slave must ensure that Bit 0 of COMxIEN0 (enable receive buffer full interrupt) is set to 1.

COMxADR is an 8-bit, read/write network address register that holds the address checked for by the network addressable UART. Upon receiving this address, the device interrupts the processor and/or sets the appropriate status bit in COMxIID1.

SERIAL PERIPHERAL INTERFACE

The ADuC7128/ADuC7129 integrate a complete hardware serial peripheral interface (SPI) on-chip. SPI is an industry-standard synchronous serial interface that allows eight bits of data to be synchronously transmitted and simultaneously received, that is, full duplex up to a maximum bit rate of 3.4 Mbs. The SPI interface is operational only with core clock divider bits POWCON[2:0] = 0, 1, or 2.

The SPI port can be configured for master or slave operation and typically consists of four pins, namely: MISO, MOSI, SCL, and CS.

MISO (Master In, Slave Out) Data I/O Pin

The MISO pin is configured as an input line in master mode and an output line in slave mode. The MISO line on the master (data in) should be connected to the MISO line in the slave device (data out). The data is transferred as byte wide (8-bit) serial data, MSB first.

MOSI (Master Out, Slave In) Pin

The MOSI pin is configured as an output line in master mode and an input line in slave mode. The MOSI line on the master (data out) should be connected to the MOSI line in the slave device (data in). The data is transferred as byte wide (8-bit) serial data, MSB first.

SCL (Serial Clock) I/O Pin

The master serial clock (SCL) is used to synchronize the data being transmitted and received through the MOSI SCL period. Therefore, a byte is transmitted/received after eight SCL periods. The SCL pin is configured as an output in master mode and as an input in slave mode.

In master mode, polarity and phase of the clock are controlled by the SPICON register, and the bit rate is defined in the SPIDIV register as follows:

$$f_{SERIAL\ CLOCK} = \frac{f_{HCLK}}{2 \times (1 + SPIDIV)}$$

In slave mode, the SPICON register must be configured with the phase and polarity of the expected input clock. The slave accepts data from an external master up to 3.4 Mbs at CD = 0.

In both master and slave modes, data is transmitted on one edge of the SCL signal and sampled on the other. Therefore, it is important that the polarity and phase be configured the same for the master and slave devices.

The maximum speed of the SPI clock is dependent on the clock divider bits and is summarized in Table 89.

Table 89. SPI Speed vs. Clock Divider Bits in Master Mode

CD Bits	0	1	2	3	4	5
SPIDIV in hex	0x05	0x0B	0x17	0x2F	0x5F	0xBF
SPI speed in MHz	3.482	1.741	0.870	0.435	0.218	0.109

In slave mode, the SPICON register must be configured with the phase and polarity of the expected input clock. The slave accepts data from an external master up to 10.4 Mbs at CD = 0. The formula to determine the maximum speed follows:

$$f_{SERIAL\ CLOCK} = \frac{f_{HCLK}}{4}$$

In both master and slave modes, data is transmitted on one edge of the SCL signal and sampled on the other. Therefore, it is important that the polarity and phase be configured the same for the master and slave devices.

Chip Select (\overline{CS}) Input Pin

In SPI slave mode, a transfer is initiated by the assertion of \overline{CS} , which is an active low input signal. The SPI port then transmits and receives 8-bit data until the transfer is concluded by desassertion of \overline{CS} . In slave mode, \overline{CS} is always an input.

SPI Registers

The following MMR registers are used to control the SPI interface: SPISTA, SPIRX, SPITX, SPIDIV, and SPICON.

SPISTA Register

Name	Address	Default Value	Access
SPISTA	0xFFFF0A00	0x00	R

SPISTA is an 8-bit read-only status register.

Table 90. SPISTA MMR Bit Designations

Bit	Description
7:6	Reserved.
5	SPIRX Data Register Overflow Status Bit. Set if SPIRX is overflowing. Cleared by reading SPIRX register.
4	SPIRX Data Register IRQ. Set automatically if Bit 3 or Bit 5 is set. Cleared by reading SPIRX register.
3	SPIRX Data Register Full Status Bit. Set automatically if valid data is present in the SPIRX register. Cleared by reading SPIRX register.
2	SPITX Data Register Underflow Status Bit. Set automatically if SPITX is underflowing. Cleared by writing in the SPITX register.
1	SPITX Data Register IRQ. Set automatically if Bit 0 is clear or Bit 2 is set. Cleared by writing in the SPITX register or if finished transmission disabling the SPI.
0	SPITX Data Register Empty Status Bit. Set by writing to SPITX to send data. This bit is set during transmission of data. Cleared when SPITX is empty.

ADuC7128/ADuC7129

SPIRX Register

Name	Address	Default Value	Access
SPIRX	0xFFFF0A04	0x00	R

SPIRX is an 8-bit read-only receive register.

SPITX Register

Name	Address	Default Value	Access
SPITX	0xFFFF0A08	0x00	W

SPITX is an 8-bit write-only transmit register.

SPIDIV Register

Name	Address	Default Value	Access
SPIDIV	0xFFFF0A0C	0x1B	R/W

SPIDIV is an 8-bit serial clock divider register.

SPICON Register

Name	Address	Default Value	Access
SPICON	0xFFFF0A10	0x0000	R/W

SPICON is a 16-bit control register.

Table 91. SPICON MMR Bit Designations

Bit	Description
15:13	Reserved.
12	Continuous Transfer Enable. Set by user to enable continuous transfer. In master mode, the transfer continues until no valid data is available in the TX register. \overline{CS} is asserted and remains asserted for the duration of each 8-bit serial transfer until TX is empty. Cleared by user to disable continuous transfer. Each transfer consists of a single 8-bit serial transfer. If valid data exists in the SPITX register, then a new transfer is initiated after a stall period.
11	Loopback Enable. Set by user to connect MISO to MOSI and test software. Cleared by user to be in normal mode.
10	Slave Output Enable. Set by user to enable the slave output. Cleared by user to disable slave output.
9	Slave Select Input Enable. Set by user in master mode to enable the output.
8	SPIRX Overflow Overwrite Enable. Set by user, the valid data in the RX register is overwritten by the new serial byte received. Cleared by user, the new serial byte received is discarded.
7	SPITX Underflow Mode. Set by user to transmit 0. Cleared by user to transmit the previous data.
6	Transfer and Interrupt Mode (Master Mode). Set by user to initiate transfer with a write to the SPITX register. Interrupt occurs when TX is empty. Cleared by user to initiate transfer with a read of the SPIRX register. Interrupt occurs when RX is full.
5	LSB First Transfer Enable Bit. Set by user, the LSB is transmitted first. Cleared by user, the MSB is transmitted first.
4	Reserved. Should be set to 0.
3	Serial Clock Polarity Mode Bit. Set by user, the serial clock idles high. Cleared by user, the serial clock idles low.
2	Serial Clock Phase Mode Bit. Set by user, the serial clock pulses at the beginning of each serial bit transfer. Cleared by user, the serial clock pulses at the end of each serial bit transfer.
1	Master Mode Enable Bit. Set by user to enable master mode. Cleared by user to enable slave mode.
0	SPI Enable Bit. Set by user to enable the SPI. Cleared to disable the SPI.

I²C-COMPATIBLE INTERFACES

The ADuC7128/ADuC7129 support two fully licensed I²C interfaces. The I²C interfaces are both implemented as full hardware master and slave interfaces. Because the two I²C interfaces are identical, only I²C0 is described in detail. Note that the two masters and slaves have individual interrupts.

Note that when configured as an I²C master device, the ADuC7128/ADuC7129 cannot generate a repeated start condition.

The two pins used for data transfer, SDA and SCL, are configured in a wire-ANDed format that allows arbitration in a multimaster system. These pins require external pull-up resistors. Typical pull-up values are 10 kΩ.

The I²C bus peripheral addresses in the I²C bus system are programmed by the user. This ID can be modified any time a transfer is not in progress. The user can configure the interface to respond to four slave addresses.

The transfer sequence of an I²C system consists of a master device initiating a transfer by generating a start condition while the bus is idle. The master transmits the address of the slave device and the direction of the data transfer in the initial address transfer. If the master does not lose arbitration and the slave acknowledges, then the data transfer is initiated. This continues until the master issues a stop condition and the bus becomes idle.

The I²C peripheral master and slave functionality are independent and can be simultaneously active. A slave is activated when a transfer has been initiated on the bus.

If it is not addressed, it remains inactive until another transfer is initiated. This also allows a master device, which has lost arbitration, to respond as a slave in the same cycle.

Serial Clock Generation

The I²C master in the system generates the serial clock for a transfer. The master channel can be configured to operate in fast mode (400 kHz) or standard mode (100 kHz).

The bit rate is defined in the I2C0DIV MMR as follows:

$$f_{SERIAL\ CLOCK} = \frac{f_{UCLK}}{(2 + DIVH) + (2 + DIVL)}$$

where:

f_{UCLK} is the clock before the clock divider.

$DIVH$ is the high period of the clock.

$DIVL$ is the low period of the clock.

Thus, for 100 kHz operation

$$DIVH = DIVL = 0xCF$$

and for 400 kHz

$$DIVH = 0x28 \quad DIVL = 0x3C.$$

The I2CxDIV register corresponds to DIVH:DIVL.

Slave Addresses

Register I2C0ID0, Register I2C0ID1, Register I2C0ID2, and Register I2C0ID3 contain the device IDs. The device compares the four I2C0IDx registers to the address byte. The seven most significant bits of either ID register must be identical to that of the seven most significant bits of the first address byte received to be correctly addressed. The LSB of the ID registers, transfer direction bit, is ignored in the process of address recognition.

I²C REGISTERS

The I²C peripheral interface consists of 18 MMRs that are discussed in this section.

I2CxMSTA Register

Name	Address	Default Value	Access
I2C0MSTA	0xFFFF0800	0x00	R
I2C1MSTA	0xFFFF0900	0x00	R

I2CxMSTA is a status register for the master channel.

Table 92. I2C0MSTA MMR Bit Designations

Bit	Description
7	Master Transmit FIFO Flush. Set by user to flush the master Tx FIFO. Cleared automatically once the master Tx FIFO is flushed. This bit also flushes the slave receive FIFO.
6	Master Busy. Set automatically if the master is busy. Cleared automatically.
5	Arbitration Loss. Set in multimaster mode if another master has the bus. Cleared when the bus becomes available.
4	No Acknowledge. Set automatically if there is no acknowledge of the address by the slave device. Cleared automatically by reading the I2C0MSTA register.
3	Master Receive IRQ. Set after receiving data. Cleared automatically by reading the I2C0MRX register.
2	Master Transmit IRQ. Set at the end of a transmission. Cleared automatically by writing to the I2C0MTX register.
1	Master Transmit FIFO Underflow. Set automatically if the master transmit FIFO is underflowing. Cleared automatically by writing to the I2C0MTX register.
0	Master TX FIFO Not Full. Set automatically if the slave transmit FIFO is not full. Cleared automatically by writing twice to the I2C0STX register.

ADuC7128/ADuC7129

I2CxSSTA Register

Name	Address	Default Value	Access
I2C0SSTA	0xFFFF0804	0x01	R
I2C1SSTA	0xFFFF0904	0x01	R

I2CxSSTA is a status register for the slave channel.

Table 93. I2CxSSTA MMR Bit Designations

Bit	Value	Description
31:15		Reserved. These bits should be written as 0.
14		START Decode Bit. Set by hardware if the device receives a valid start and matching address. Cleared by an I ² C stop condition or an I ² C general call reset.
13		Repeated START Decode Bit. Set by hardware if the device receives a valid repeated start and matching address. Cleared by an I ² C stop condition, a read of the I2CxSSTA register, or an I ² C general call reset.
12:11	00 01 10 11	ID Decode Bits. Received Address Matched ID Register 0. Received Address Matched ID Register 1. Received Address Matched ID Register 2. Received Address Matched ID Register 3.
10		Stop After Start And Matching Address Interrupt. Set by hardware if the slave device receives an I ² C STOP condition after a previous I ² C START condition and matching address. Cleared by a read of the I2CxSSTA register.
9:8	00 01 10 11	General Call ID. No General Call. General Call Reset and Program Address. General Call Program Address. General Call Matching Alternative ID.
7		General Call Interrupt. Set if the slave device receives a general call of any type. Cleared by setting Bit 8 of the I2CxCFG register. If it is a general call reset, all registers are at their default values. If it is a hardware general call, the Rx FIFO holds the second byte of the general call. This is similar to the I2C0ALT register (unless it is a general call to reprogram the device address). For more details, see the I ² C Bus Specification, Version 2.1, Jan. 2000.
6		Slave Busy. Set automatically if the slave is busy. Cleared automatically.
5		No Acknowledge. Set if master asks for data and no data is available. Cleared automatically by reading the I2C0SSTA register.
4		Slave Receive FIFO Overflow. Set automatically if the slave receive FIFO is overflowing. Cleared automatically by reading I2C0SRX register.
3		Slave Receive IRQ. Set after receiving data. Cleared automatically by reading the I2C0SRX register or flushing the FIFO.
2		Slave Transmit IRQ. Set at the end of a transmission. Cleared automatically by writing to the I2C0STX register.
1		Slave Transmit FIFO Underflow. Set automatically if the slave transmit FIFO is underflowing. Cleared automatically by writing to the I2C0STX register.
0		Slave Transmit FIFO Empty. Set automatically if the slave transmit FIFO is empty. Cleared automatically by writing twice to the I2C0STX register.

I2CxSRX Register

Name	Address	Default Value	Access
I2C0SRX	0xFFFFF0808	0x00	R
I2C1SRX	0xFFFFF0908	0x00	R

I2CxSRX is a receive register for the slave channel.

I2CxSTX Register

Name	Address	Default Value	Access
I2C0STX	0xFFFFF080C	0x00	W
I2C1STX	0xFFFFF090C	0x00	W

I2CxSTX is a transmit register for the slave channel.

I2CxMRX Register

Name	Address	Default Value	Access
I2C0MRX	0xFFFFF0810	0x00	R
I2C1MRX	0xFFFFF0910	0x00	R

I2CxMRX is a receive register for the master channel.

I2CxMTX Register

Name	Address	Default Value	Access
I2C0MTX	0xFFFFF0814	0x00	W
I2C1MTX	0xFFFFF0914	0x00	W

I2CxMTX is a transmit register for the master channel.

I2CxCNT Register

Name	Address	Default Value	Access
I2C0CNT	0xFFFFF0818	0x00	R/W
I2C1CNT	0xFFFFF0918	0x00	R/W

I2CxCNT is a master receive data count register. If a master read transfer sequence is initiated, the I2CxCNT register denotes the number of bytes (-1) to be read from the slave device. By default this counter is 0, which corresponds to the expected one byte.

Table 94. I2C0CFG MMR Bit Designations

Bit	Description
31:15	Reserved. These bits should be written by the user as 0.
14	Enable Stop Interrupt. Set by user to generate an interrupt upon receiving a stop condition and after receiving a valid start condition and matching address. Cleared by user to disable the generation of an interrupt upon receiving a stop condition.
13	Reserved. This bit should be written by the user as 0.
12	Reserved. This bit should be written by the user as 0.
11	Enable Stretch SCL. Holds SCL low. Set by user to stretch the SCL line. Cleared by user to disable stretching of the SCL line.
10	Reserved. This bit should be written by the user as 0.
9	Slave Tx FIFO Request Interrupt Enable. Cleared by user to generate an interrupt request just after the negative edge of the clock for the R/W bit. This allows the user to input data into the slave Tx FIFO if it is empty. At 400 kSPS, and with the core clock running at 41.78 MHz, the user has 45 clock cycles to take appropriate action, taking interrupt latency into account. Set by user to disable the slave Tx FIFO request interrupt.
8	General Call Status Bit Clear. Set by user to clear the general call status bits. Cleared automatically by hardware after the general call status bits have been cleared.

I2CxADR Register

Name	Address	Default Value	Access
I2C0ADR	0xFFFFF081C	0x00	R/W
I2C1ADR	0xFFFFF091C	0x00	R/W

I2CxADR is a master address byte register. The I2CxADR value is the device address that the master wants to communicate with. It is automatically transmitted at the start of a master transfer sequence if there is no valid data in the I2CxMTX register when the master enable bit is set.

I2CxBYT Register

Name	Address	Default Value	Access
I2C0BYT	0xFFFFF0824	0x00	R/W
I2C1BYT	0xFFFFF0924	0x00	R/W

I2CxBYT is a broadcast byte register.

I2CxALT Register

Name	Address	Default Value	Access
I2C0ALT	0xFFFFF0828	0x00	R/W
I2C1ALT	0xFFFFF0928	0x00	R/W

I2CxALT is a hardware general call ID register used in slave mode.

I2CxCFG Register

Name	Address	Default Value	Access
I2C0CFG	0xFFFFF082C	0x00	R/W
I2C1CFG	0xFFFFF092C	0x00	R/W

I2CxCFG is a configuration register.

ADuC7128/ADuC7129

Bit	Description
7	Master Serial Clock Enable Bit. Set by user to enable generation of the serial clock in master mode. Cleared by user to disable serial clock in master mode.
6	Loop-Back Enable Bit. Set by user to internally connect the transition to the reception to test user software. Cleared by user to operate in normal mode.
5	Start Back-Off Disable Bit. Set by user in multimaster mode. If losing arbitration, the master immediately tries to retransmit. Cleared by user to enable start back-off. After losing arbitration, the master waits before trying to retransmit.
4	Hardware General Call Enable. When this bit and Bit 3 are set, and have received a general call (Address 0x00) and a data byte, the device checks the contents of the I2C0ALT against the receive register. If the contents match, the device has received a hardware general call. This is used if a device needs urgent attention from a master device without knowing which master it needs to turn to. This is a "to whom it may concern" call. The ADuC7128/ADuC7129 watch for these addresses. The device that requires attention embeds its own address into the message. All masters listen and the one that can handle the device contacts its slave and acts appropriately. The LSB of the I2C0ALT register should always be written to a 1, as per the I ² C January 2000 specification.
3	General Call Enable Bit. Set this bit to enable the slave device to acknowledge an I ² C general call, Address 0x00 (write). The device then recognizes a data bit. If it receives a 0x06 (reset and write programmable part of slave address by hardware) as the data byte, the I ² C interface resets as per the I ² C January 2000 specification. This command can be used to reset an entire I ² C system. The general call interrupt status bit sets on any general call. The user must take corrective action by setting up the I ² C interface after a reset. If it receives a 0x04 (write programmable part of slave address by hardware) as the data byte, the general call interrupt status bit sets on any general call. The user must take corrective action by reprogramming the device address.
2	Reserved.
1	Master Enable Bit. Set by user to enable the master I ² C channel. Cleared by user to disable the master I ² C channel.
0	Slave Enable Bit. Set by user to enable the slave I ² C channel. A slave transfer sequence is monitored for the device address in I2C0ID0, I2C0ID1, I2C0ID2, and I2C0ID3. If the device address is recognized, the part participates in the slave transfer sequence. Cleared by user to disable the slave I ² C channel.

I2CxDIV Register

Name	Address	Default Value	Access
I2C0DIV	0xFFFF0830	0x1F1F	R/W
I2C1DIV	0xFFFF0930	0x1F1F	R/W

I2CxDIV are the clock divider registers.

I2CxIDx Register

Name	Address	Default Value	Access
I2C0ID0	0xFFFF0838	0x00	R/W
I2C0ID1	0xFFFF083C	0x00	R/W
I2C0ID2	0xFFFF0840	0x00	R/W
I2C0ID3	0xFFFF0844	0x00	R/W
I2C1ID0	0xFFFF0938	0x00	R/W
I2C1ID1	0xFFFF093C	0x00	R/W
I2C1ID2	0xFFFF0940	0x00	R/W
I2C1ID3	0xFFFF0944	0x00	R/W

I2CxID0, I2CxID1, I2CxID2, and I2CxID3 are slave address device ID registers of I2Cx.

I2CxSSC Register

Name	Address	Default Value	Access
I2C0SSC	0xFFFF0848	0x01	R/W
I2C1SSC	0xFFFF0948	0x01	R/W

I2CxSSC is an 8-bit start/stop generation counter. It holds off SDA low for start and stop conditions.

I2CxFIF Register

Name	Address	Default Value	Access
I2C0FIF	0xFFFF084C	0x0000	R
I2C1FIF	0xFFFF094C	0x0000	R

I2CxFIF is a FIFO status register.

Table 95. I2C0FIF MMR Bit Designations

Bit	Value	Description
15:10		Reserved.
9		Master Transmit FIFO Flush. Set by user to flush the master Tx FIFO. Cleared automatically once the master Tx FIFO is flushed. This bit also flushes the slave receive FIFO.
8		Slave Transmit FIFO Flush. Set by user to flush the slave Tx FIFO. Cleared automatically once the slave Tx FIFO is flushed.
7:6	00 01 10 11	Master Rx FIFO Status Bits. FIFO Empty. Byte Written to FIFO. 1 Byte in FIFO. FIFO Full.
5:4	00 01 10 11	Master Tx FIFO Status Bits. FIFO Empty. Byte Written to FIFO. 1 Byte in FIFO. FIFO Full.
3:2	00 01 10 11	Slave Rx FIFO Status Bits. FIFO Empty. Byte Written to FIFO. 1 Byte in FIFO. FIFO Full.
1:0	00 01 10 11	Slave Tx FIFO Status Bits. FIFO Empty. Byte Written to FIFO. 1 Byte in FIFO. FIFO full.

PROGRAMMABLE LOGIC ARRAY (PLA)

The ADuC7128/ADuC7129 integrate a fully programmable logic array (PLA) that consists of two independent but interconnected PLA blocks. Each block consists of eight PLA elements, giving a total of 16 PLA elements.

A PLA element contains a two input look-up table that can be configured to generate any logic output function based on two inputs and a flip-flop as represented in Figure 54.

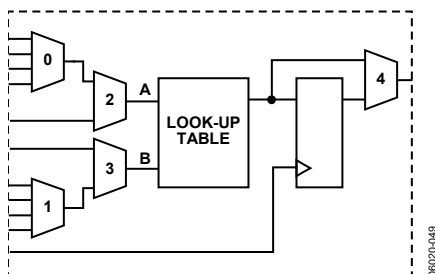

Figure 54. PLA Element

In total, 30 GPIO pins are available on the ADuC7128/ADuC7129 for the PLA. These include 16 input pins and 14 output pins. They need to be configured in the GPxCON register as PLA pins before using the PLA. Note that the comparator output is also included as one of the 16 input pins.

The PLA is configured via a set of user MMRs and the output(s) of the PLA can be routed to the internal interrupt system, to the CONVST signal of the ADC, to an MMR, or to any of the 16 PLA output pins.

The interconnection between the two blocks is supported by connecting the output of Element 7 of Block 1 fed back to the Input 0 of Mux 0 of Element 0 of Block 0, and the output of Element 7 of Block 0 is fed back to the Input 0 of Mux 0 of Element 0 of Block 1.

ADuC7128/ADuC7129

Table 96. Element Input/Output

PLA Block 0			PLA Block 1		
Element	Input	Output	Element	Input	Output
0	P1.0	P1.7	8	P3.0	P4.0
1	P1.1	P0.4	9	P3.1	P4.1
2	P1.2	P0.5	10	P3.2	P4.2
3	P1.3	P0.6	11	P3.3	P4.3
4	P1.4	P0.7	12	P3.4	P4.4
5	P1.5	P2.0	13	P3.5	P4.5
6	P1.6	P2.1	14	P3.6	P4.6
7	P0.0	P2.2	15	P3.7	P4.7

PLA MMRs Interface

The PLA peripheral interface consists on 21 MMRs, as shown in Table 97.

Table 97. PLA MMRs

Name	Description
PLAELMx	Element 0 to Element 15 Control Registers. Configure the input and output mux of each element, select the function in the look-up table, and bypass/use the flip-flop.
PLACLK	Clock Selection for the Flip-Flops of Block 0 and Clock Selection for the Flip-Flops of Block 1.
PLAIRQ	Enable IRQ0 and/or IRQ1. Select the source of the IRQ.
PLAADC	PLA Source from ADC Start Conversion Signal.
PLADIN	Data Input MMR for PLA.
PLAOUT	Data Output MMR for PLA. This register is always updated.

A PLA tool is provided in the development system to easily configure the PLA.

Table 98. PLAELMx MMR Bit Designations

Bit	Value	PLAELM0	PLAELM1 to PLAELM7	PLAELM8	PLAELM9 to PLAELM15	Description
31:11						Reserved.
10:9	00	Element 15	Element 0	Element 7	Element 8	Mux (0) Control. Select feedback source.
	01	Element 2	Element 2	Element 10	Element 10	
	10	Element 4	Element 4	Element 12	Element 12	
	11	Element 6	Element 6	Element 14	Element 14	
8:7	00	Element 1	Element 1	Element 9	Element 9	Mux (1) Control. Select feedback source.
	01	Element 3	Element 3	Element 11	Element 11	
	10	Element 5	Element 5	Element 13	Element 13	
	11	Element 7	Element 7	Element 15	Element 15	
6						Mux (2) Control. Set by user to select the output of Mux (0). Cleared by user to select the bit value from PLADIN.
5						Mux (3) Control. Set by user to select the input pin of the particular element. Cleared by user to select the output of Mux (1).
4:1	0000					Look-Up Table Control. 0 NOR B AND NOT A NOT A A AND NOT B NOT B EXOR NAND AND EXNOR B NOT A OR B A A OR NOT B OR 1
	0001					
	0010					
	0011					
	0100					
	0101					
	0110					
	0111					
	1000					
	1001					
	1010					
	1011					
	1100					
	1101					
	1110					
	1111					
0						Mux (4) Control. Set by user to bypass the flip-flop. Cleared by user to select the flip-flop. Cleared by default.

Table 99. PLACLK MMR Bit Designations

Bit	Value	Description
7		Reserved.
6:4		Block 1 Clock Source Selection.
	000	GPIO Clock on P0.5.
	001	GPIO Clock on P0.0.
	010	GPIO Clock on P0.7.
	011	HCLK.
	100	OCLK.
	101	Timer1 Overflow.
	110	Timer4 Overflow.
	Other	Reserved.
3		Reserved.
2:0		Block 0 Clock Source Selection.
	000	GPIO Clock on P0.5.
	001	GPIO Clock on P0.0.
	010	GPIO Clock on P0.7.
	011	HCLK.
	100	OCLK.
	101	Timer1 Overflow.
	110	Timer4 Overflow.
	Other	Reserved.

Table 100. PLAIRQ MMR Bit Designations

Bit	Value	Description
15:13		Reserved.
12		PLA IRQ1 Enable Bit Set by user to enable IRQ1 output from PLA Cleared by user to disable IRQ1 output from PLA
11:8		PLA IRQ1 Source.
	0000	PLA Element 0.
	0001	PLA Element 1.
	...	
	1111	PLA Element 15.
7:5		Reserved.
4		PLA IRQ0 Enable Bit. Set by user to enable IRQ0 output from PLA. Cleared by user to disable IRQ0 output from PLA.
3:0		PLA IRQ0 Source.
	0000	PLA Element 0.
	0001	PLA Element 1.
	...	
	1111	PLA Element 15.

Table 101. PLAADC MMR Bit Designations

Bit	Value	Description
31:5		Reserved.
4		ADC Start Conversion Enable Bit. Set by user to enable ADC start conversion from PLA. Cleared by user to disable ADC start conversion from PLA.
3:0		ADC Start Conversion Source.
	0000	PLA Element 0.
	0001	PLA Element 1.
	...	
	1111	PLA Element 15.

Table 102. PLADIN MMR Bit Designations

Bit	Description
31:16	Reserved.
15:0	Input Bit from Element 15 to Element 0.

Table 103. PLAOUT MMR Bit Designations

Bit	Description
31:16	Reserved.
15:0	Output Bit from Element 15 to Element 0.

PROCESSOR REFERENCE PERIPHERALS

INTERRUPT SYSTEM

There are 30 interrupt sources on the ADuC7128/ADuC7129 controlled by the interrupt controller. Most interrupts are generated from the on-chip peripherals, such as ADC and UART. Two additional interrupt sources are generated from external interrupt request pins, XIRQ0 and XIRQ1. The ARM7TDMI CPU core only recognizes interrupts as one of two types: a normal interrupt request (IRQ) or a fast interrupt request (FIQ). All the interrupts can be masked separately.

The control and configuration of the interrupt system are managed through nine interrupt-related registers, four dedicated to IRQ, four dedicated to FIQ, and an additional MMR that is used to select the programmed interrupt source. The bits in each IRQ and FIQ register represent the same interrupt source as described in Table 104.

Table 104. IRQ/FIQ MMRs Bit Designations

Bit	Description
0	FIQ Source.
1	SWI. Not used in IRQEN/CLR and FIQEN/CLR.
2	Timer0.
3	Timer1.
4	Wake-Up Timer—Timer2.
5	Watchdog Timer—Timer3.
6	Timer4.
7	Flash Controller 0.
8	Flash Controller 1.
9	ADC.
10	Quadrature Encoder.
11	I2C0 Slave.
12	I2C1 Slave.
13	I2C0 Master.
14	I2C1 Master.
15	SPI Slave.
16	SPI Master.
17	UART0.
18	UART1.
19	External IRQ0.
20	Comparator.
21	PSM.
22	External IRQ1.
23	PLA IRQ0.
24	PLA IRQ1.
25	External IRQ2.
26	External IRQ3.
27	PWM Trip.
28	PLL Lock.
29	Reserved.
30	Reserved.

IRQ

The interrupt request (IRQ) is the exception signal to enter the IRQ mode of the processor. It is used to service general-purpose interrupt handling of internal and external events.

The four 32-bit registers dedicated to IRQ are listed in Table 105.

Table 105. IRQ Interface MMRs

Register	Description
IRQSIG	Reflects the status of the different IRQ sources. If a peripheral generates an IRQ signal, the corresponding bit in the IRQSIG is set; otherwise, it is cleared. The IRQSIG bits are cleared when the interrupt in the particular peripheral is cleared. All IRQ sources can be masked in the IRQEN MMR. IRQSIG is read only.
IRQEN	Provides the value of the current enable mask. When set to 1, the source request is enabled to create an IRQ exception. When set to 0, the source request is disabled or masked but does not create an IRQ exception. To clear a bit in IRQEN, use the IRQCLR MMR.
IRQCLR	Write-only register allows clearing the IRQEN register to mask an interrupt source. Each bit set to 1 clears the corresponding bit in the IRQEN register without affecting the remaining bits. The pair of registers, IRQEN and IRQCLR, allows independent manipulation of the enable mask without requiring an automatic read-modify-write.
IRQSTA	Read-only register provides the current enabled IRQ source status. When set to 1, that source should generate an active IRQ request to the ARM7TDMI core. There is no priority encoder or interrupt vector generation. This function is implemented in software in a common interrupt handler routine. All 32 bits are logically OR'ed to create the IRQ signal to the ARM7TDMI core.

FIQ

The fast interrupt request (FIQ) is the exception signal to enter the FIQ mode of the processor. It is provided to service data transfer or communication channel tasks with low latency. The FIQ interface is identical to the IRQ interface providing the second level interrupt (highest priority). Four 32-bit registers are dedicated to FIQ: FIQSIG, FIQEN, FIQCLR, and FIQSTA.

Bit 31 to Bit 1 of FIQSTA are logically OR'ed to create the FIQ signal to the core and Bit 0 of both the FIQ and IRQ registers (FIQ source).

The logic for FIQEN and FIQCLR does not allow an interrupt source to be enabled in both IRQ and FIQ masks. A bit set to 1 in FIQEN, as a side effect, clears the same bit in IRQEN. A bit set to 1 in IRQEN, as a side effect, clears the same bit in FIQEN. An interrupt source can be disabled in both IRQEN and FIQEN masks.

Programmed Interrupts

As the programmed interrupts are nonmaskable, they are controlled by the SWICFG register that writes into both the IRQSTA and IRQSIG registers and/or FIQSTA and FIQSIG registers at the same time. The 32-bit register dedicated to software interrupt is SWICFG described in Table 106. This MMR allows the control of programmed source interrupt.

Table 106. SWICFG MMR Bit Designations

Bit	Description
31:3	Reserved.
2	Programmed Interrupt (FIQ). Setting/clearing this bit corresponds to setting/clearing Bit 1 of FIQSTA and FIQSIG.
1	Programmed Interrupt (IRQ). Setting/clearing this bit corresponds to setting/clearing Bit 1 of IRQSTA and IRQSIG.
0	Reserved.

Note that any interrupt signal must be active for at least the equivalent of the interrupt latency time, to be detected by the interrupt controller and to be detected by the user in the IRQSTA/FIQSTA register.

TIMERS

The ADuC7128/ADuC7129 have five general purpose timers/counters.

- Timer0
- Timer1
- Timer2 or wake-up timer
- Timer3 or watchdog timer
- Timer4

The five timers in their normal mode of operation can be either free-running or periodic.

In free-running mode, the counter decrements or increments from the maximum or minimum value until zero scale or full scale and starts again at the maximum or minimum value.

In periodic mode, the counter decrements/increments from the value in the load register (TxLD MMR) until zero scale or full scale and starts again at the value stored in the load register.

The value of a counter can be read at any time by accessing its value register (TxVAL). Timers are started by writing in the control register of the corresponding timer (TxCON).

In normal mode, an IRQ is generated each time the value of the counter reaches zero, if counting down; or full scale, if counting up. An IRQ can be cleared by writing any value to clear the register of the particular timer (TxICLR).

Table 107. Event Selection Numbers

ES	Interrupt Number	Name
00000	2	RTOS Timer (Timer0)
00001	3	GP Timer0 (Timer1)
00010	4	Wake-Up Timer (Timer2)
00011	5	Watchdog Timer (Timer3)
00100	6	GP Timer1 (Timer4)
00101	7	Flash Control 0
00110	8	Flash Control 1
00111	9	ADC Channel
01000	10	Quadrature Encoder
01001	11	I2C Slave0
01010	12	I2C Slave1
01011	13	I2C Master0
01100	14	I2C Master1
01101	15	SPI Slave
01110	16	SPI Master
01111	17	UART0
10000	18	UART1
10001	19	External IRQ0

TIMERO—LIFETIME TIMER

Timer0 is a general-purpose, 48-bit count up, or a 16-bit count up/down timer with a programmable prescaler. Timer0 is clocked from the core clock, with a prescaler of 1, 16, 256, or 32,768. This gives a minimum resolution of 22 ns when the core is operating at 41.78 MHz and with a prescaler of 1.

In 48-bit mode, Timer0 counts up from zero. The current counter value can be read from T0VAL0 and T0VAL1.

In 16-bit mode, Timer0 can count up or count down. A 16-bit value can be written to T0LD, which is loaded into the counter. The current counter value can be read from T0VAL0. Timer0 has a capture register (T0CAP) that can be triggered by a selected IRQ source initial assertion. Once triggered, the current timer value is copied to T0CAP, and the timer keeps running. This feature can be used to determine the assertion of an event with more accuracy than by servicing an interrupt alone.

Timer0 reloads the value from T0LD either when TIMERO overflows or immediately when T0ICLR is written.

ADuC7128/ADuC7129

The Timer0 interface consists of six MMRs, shown in Table 108.

Table 108. Timer0 Interface MMRs

Name	Description
TOLD	A 16-bit register that holds the 16-bit value loaded into the counter. Available only in 16-bit mode.
TOCAP	A 16-bit register that holds the 16-bit value captured by an enabled IRQ event. Available only in 16-bit mode.
TOVAL0/ TOVAL1	TOVAL0 is a 16 bit register that holds the 16 least significant bits (LSBs). TOVAL1 is a 32-bit register that holds the 32 most significant bits (MSBs). TOVAL0 and TOVAL1 are read only. In 16-bit mode, 16-bit TOVAL0 is used. In 48-bit mode, both 16-bit TOVAL0 and 32-bit TOVAL1 are used.
TOICLR	An 8-bit register. Writing any value to this register clears the interrupt. Available only in 16-bit mode.
TOCON	The configuration MMR (see Table 109).



Figure 55. Timer0 Block Diagram

Timer0 Value Register

Name	Address	Default Value	Access
TOVAL0	0xFFFF0304	0x00	R
TOVAL1	0xFFFF0308	0x00	R

TOVAL0 and TOVAL1 are 16-bit and 32-bit registers that hold the 16 least significant bits and 32 most significant bits, respectively. TOVAL0 and TOVAL1 are read-only. In 16-bit mode, 16-bit TOVAL0 is used. In 48-bit mode, both 16-bit TOVAL0 and 32-bit TOVAL1 are used.

Timer0 Capture Register

Name	Address	Default Value	Access
TOCAP	0xFFFF0314	0x00	R

This is a 16-bit register that holds the 16-bit value captured by an enabled IRQ event; available only in 16-bit mode.

Timer0 Control Register

Name	Address	Default Value	Access
TOCON	0xFFFF030C	0x00	R/W

The 17-bit MMR configures the mode of operation of Timer0.

Table 109. TOCON MMR Bit Designations

Bit	Value	Description
31:18		Reserved.
17		Event Select Bit. Set by user to enable time capture of an event. Cleared by user to disable time capture of an event.
16:12		Event Select Range, 0 to 31. The events are as described in the Timers section.
11		Reserved.
10:9		Reserved.
8		Count Up. Available only in 16-bit mode. Set by user for timer 0 to count up. Cleared by user for timer 0 to count down (default).
7		Timer0 Enable Bit. Set by user to enable Timer0. Cleared by user to disable Timer0 (default).
6		Timer0 Mode. Set by user to operate in periodic mode. Cleared by user to operate in free-running mode (default).
5		Reserved.
4	0	Timer0 Mode of Operation. 16-bit operation (default).
	1	48-bit operation.
3:0	0000	Prescaler. Source clock/1 (default).
	0100	Source clock/16.
	1000	Source clock/256.
	1111	Source clock/32,768.

Timer0 Load Register

Name	Address	Default Value	Access
TOLD	0xFFFF0300	0x00	R/W

TOLD is a 16-bit register that holds the 16-bit value that is loaded into the counter; available only in 16-bit mode.

Timer0 Clear Register

Name	Address	Default Value	Access
TOICLR	0xFFFF0310	0x00	W

This 8-bit, write-only MMR is written (with any value) by user code to refresh (reload) Timer0.

TIMER1—GENERAL-PURPOSE TIMER

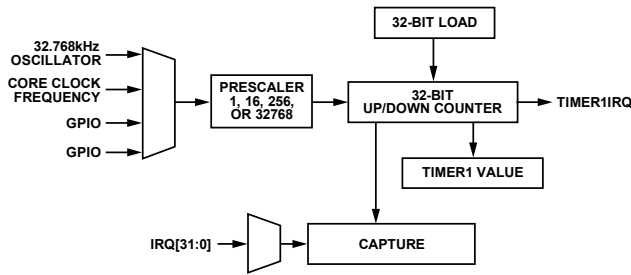

Figure 56. Timer1 Block Diagram

Timer1 is a 32-bit general-purpose count down or count up timer with a programmable prescaler. The prescaler source can be from the 32 kHz oscillator, the core clock, or one of two external GPIOs. This source can be scaled by a factor of 1, 16, 256, or 32,768. This gives a minimum resolution of 42 ns when operating at CD zero, the core is operating at 41.78 MHz, and with a prescaler of 1 (ignoring external GPIO).

The counter can be formatted as a standard 32-bit value or as hours:minutes:seconds:hundredths.

Timer1 has a capture register (T1CAP) that can be triggered by a selected IRQ source initial assertion. Once triggered, the current timer value is copied to T1CAP, and the timer keeps running. This feature can be used to determine the assertion of an event with increased accuracy.

The Timer1 interface consists of five MMRs, as shown in Table 110.

Table 110. Timer1 Interface MMRs

Name	Description
T1LD	A 32-bit register. Holds 32-bit unsigned integers. This register is read only.
T1VAL	A 32-bit register. Holds 32-bit unsigned integers.
T1CAP	A 32-bit register. Holds 32-bit unsigned integers. This register is read only.
T1ICLR	An 8-bit register. Writing any value to this register clears the Timer1 interrupt.
T1CON	The configuration MMR (see Table 111).

Note that if the part is in a low power mode, and Timer1 is clocked from the GPIO or low power oscillator source, then Timer1 continues to operate.

Timer1 reloads the value from T1LD either when Timer1 overflows or immediately after T1ICLR is written.

Timer1 Load Register

Name	Address	Default Value	Access
T1LD	0xFFFF0320	0x00000	R/W

T1LD is a 32-bit register that holds the 32-bit value that is loaded into the counter.

Timer1 Clear Register

Name	Address	Default Value	Access
T1ICLR	0xFFFF032C	0x00	W

This 8-bit, write-only MMR is written (with any value) by user code to refresh (reload) Timer1.

Timer1 Value Register

Name	Address	Default Value	Access
T1VAL	0xFFFF0324	0x0000	R

T1VAL is a 32-bit register that holds the current value of Timer1.

Timer1 Capture Register

Name	Address	Default Value	Access
T1CAP	0xFFFF0330	0x00	R

This is a 32-bit register that holds the 32-bit value captured by an enabled IRQ event.

Timer1 Control Register

Name	Address	Default Value	Access
T1CON	0xFFFF0328	0x0000	R/W

This 32-bit MMR configures the mode of operation of Timer1.

ADuC7128/ADuC7129

Table 111. T1CON MMR Bit Designations

Bit	Value	Description
31:18		Reserved. Should be set to 0 by the user.
17		Event Select Bit. Set by user to enable time capture of an event. Cleared by user to disable time capture of an event.
16:12		Event Select Range, 0 to 31. The events are as described in the introduction to the timers.
11:9		Clock Select.
	000	Core Clock (Default).
	001	32.768 kHz Oscillator.
	010	P1.0.
	011	P0.6.
8		Count Up. Set by user for Timer1 to count up. Cleared by user for Timer1 to count down (default).
7		Timer1 Enable Bit. Set by user to enable Timer1. Cleared by user to disable Timer1 (default).
6		Timer1 Mode. Set by user to operate in periodic mode. Cleared by user to operate in free-running mode (default).
5:4		Format.
	00	Binary (Default).
	01	Reserved.
	10	Hours:Minutes:Seconds:Hundredths: 23 Hours to 0 Hours.
	11	Hours:Minutes:Seconds:Hundredths: 255 Hours to 0 Hours.
3:0		Prescaler.
	0000	Source Clock/1 (Default).
	0100	Source Clock/16.
	1000	Source Clock/256.
	1111	Source Clock/32768.

TIMER2—WAKE-UP TIMER

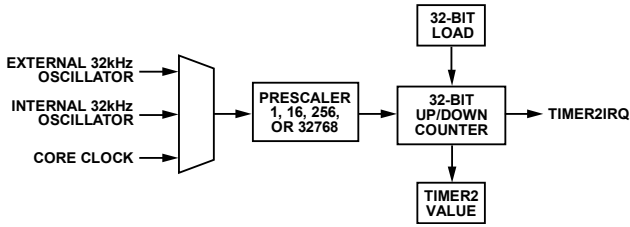

Figure 57. Timer2 Block Diagram

Timer2 is a 32-bit wake-up timer, count down or count up, with a programmable prescaler. The prescaler is clocked directly from one of four clock sources, namely, the core clock (default selection), the internal 32.768 kHz oscillator, the external 32.768 kHz watch crystal, or the core clock. The selected clock source can be scaled by a factor of 1, 16, 256, or 32768. The wake-up timer continues to run when the core clock is disabled. This gives a minimum resolution of 22 ns when the core is operating at 41.78 MHz and with a prescaler of 1. Capture of the current timer value is enabled if the Timer2 interrupt is enabled via IRQEN[4].

The counter can be formatted as plain 32-bit value or as hours:minutes:seconds:hundredths.

Timer2 reloads the value from T2LD either when Timer2 overflows or immediately after T2ICLR is written.

The Timer2 interface consists of four MMRs, as shown in Table 112.

Table 112. Timer2 Interface MMRs

Name	Description
T2LD	A 32-bit register. Holds 32-bit unsigned integers.
T2VAL	A 32-bit register. Holds 32-bit unsigned integers. This register is read only.
T2ICLR	An 8-bit register. Writing any value to this register clears the Timer2 interrupt.
T2CON	The configuration MMR (see Table 113).

Timer2 Load Register

Name	Address	Default Value	Access
T2LD	0xFFFF0340	0x00000	R/W

T2LD is a 32-bit register that holds the 32 bit value that is loaded into the counter.

Timer2 Clear Register

Name	Address	Default Value	Access
T2ICLR	0xFFFF034C	0x00	W

This 8-bit write-only MMR is written (with any value) by user code to refresh (reload) Timer2.

Timer2 Value Register

Name	Address	Default Value	Access
T2VAL	0xFFFF0344	0x0000	R

T2VAL is a 32-bit register that holds the current value of Timer2.

Timer2 Control Register

Name	Address	Default Value	Access
T2CON	0xFFFF0348	0x0000	R/W

This 32-bit MMR configures the mode of operation for Timer2.

ADuC7128/ADuC7129

Table 113. T2CON MMR Bit Designations

Bit	Value	Description
31:11		Reserved.
10:9		Clock Source Select.
	00	Core Clock (Default).
	01	Internal 32.768 kHz Oscillator.
	10	External 32.768 kHz Watch Crystal.
	11	External 32.768 kHz Watch Crystal.
8		Count Up. Set by user for Timer2 to count up. Cleared by user for Timer2 to count down (default).
7		Timer2 Enable Bit. Set by user to enable Timer2. Cleared by user to disable Timer2 (default).
6		Timer2 Mode. Set by user to operate in periodic mode. Cleared by user to operate in free-running mode (default).
5:4		Format.
	00	Binary (Default).
	01	Reserved.
	10	Hours:Minutes:Seconds:Hundredths: 23 Hours to 0 Hours.
	11	Hours:Minutes:Seconds:Hundredths: 255 Hours to 0 Hours.
3:0		Prescaler.
	0000	Source Clock/1 (Default).
	0100	Source Clock/16.
	1000	Source Clock/256. This setting should be used in conjunction with Timer2 formats 1,0 and 1,1.
	1111	Source Clock/32,768.

TIMER3—WATCHDOG TIMER

Figure 58. Timer3 Block Diagram

Timer3 has two modes of operation: normal mode and watchdog mode. The watchdog timer is used to recover from an illegal software state. Once enabled, it requires periodic servicing to prevent it from forcing a reset of the processor.

Timer3 reloads the value from T3LD either when Timer3 overflows or immediately after T3ICLR is written.

Normal Mode

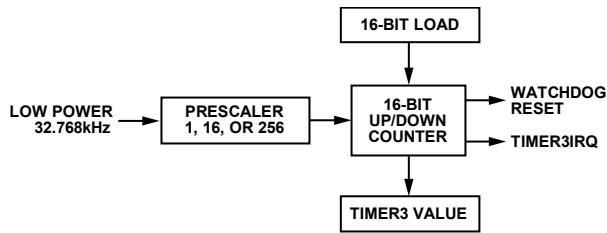
The Timer3 in normal mode is identical to Timer0 in 16-bit mode of operation, except for the clock source. The clock source is the 32.768 kHz oscillator and can be scaled by a factor of 1, 16, or 256. Timer3 also features a capture facility that allows capture of the current timer value if the Timer2 interrupt is enabled via IRQEN[5].

Watchdog Mode

Watchdog mode is entered by setting T3CON[5]. Timer3 decrements from the timeout value present in the T3LD register to 0. The maximum timeout is 512 seconds, using the maximum prescaler/256 and full scale in T3LD.

User software should only configure a minimum timeout period of 30 ms. This is to avoid any conflict with Flash/EE memory page erase cycles, which require 20 ms to complete a single page erase cycle and kernel execution.

If T3VAL reaches 0, a reset or an interrupt occurs, depending on T3CON[1]. To avoid a reset or an interrupt event, any value can be written to T3ICLR before T3VAL reaches 0. This reloads the counter with T3LD and begins a new timeout period.

Once watchdog mode is entered, T3LD and T3CON are write protected. These two registers cannot be modified until a power-on reset event resets the watchdog timer. After any other reset event, the watchdog timer continues to count. The watchdog timer should be configured in the initial lines of user code to avoid an infinite loop of watchdog resets.

Timer3 is automatically halted during JTAG debug access and only recommences counting once JTAG has relinquished control of the ARM7 core. By default, Timer3 continues to count during power-down. This can be disabled by setting Bit 0 in T3CON. It is recommended that the default value is used, that is, the watchdog timer continues to count during power-down.

Timer3 Interface

The Timer3 interface consists of four MMRs, as shown in Table 114.

Table 114. Timer3 Interface MMRs

Name	Description
T3CON	The configuration MMR (see Table 115).
T3LD	A 16-bit register (Bit 0 to Bit15). Holds 16-bit unsigned integers.
T3VAL	A 16-bit register (Bit 0 to Bit 15). Holds 16-bit unsigned integers. This register is read only.
T3ICLR	An 8-bit register. Writing any value to this register clears the Timer3 interrupt in normal mode or resets a new timeout period in watchdog mode.

Timer3 Load Register

Name	Address	Default Value	Access
T3LD	0xFFFF0360	0x03D7	R/W

This 16-bit MMR holds the Timer3 reload value.

Timer3 Value Register

Name	Address	Default Value	Access
T3VAL	0xFFFF0364	0x03D7	R

This 16-bit, read-only MMR holds the current Timer3 count value.

Timer3 Clear Register

Name	Address	Default Value	Access
T3ICLR	0xFFFF036C	0x00	W

This 8-bit, write-only MMR is written (with any value) by user code to refresh (reload) Timer3 in watchdog mode to prevent a watchdog timer reset event.

Timer3 Control Register

Name	Address	Default Value	Access
T3CON	0xFFFF0368	0x00	R/W once only

The 16-bit MMR configures the mode of operation of Timer3, as described in detail in Table 115.

ADuC7128/ADuC7129

Table 115. T3CON MMR Bit Designations

Bit	Value	Description
16:9		These bits are reserved and should be written as 0s by user code.
8		Count Up/Down Enable. Set by user code to configure Timer3 to count up. Cleared by user code to configure Timer3 to count down.
7		Timer3 Enable. Set by user code to enable Timer3. Cleared by user code to disable Timer3.
6		Timer3 Operating Mode. Set by user code to configure Timer3 to operate in periodic mode. Cleared by user to configure Timer3 to operate in free-running mode.
5		Watchdog Timer Mode Enable. Set by user code to enable watchdog mode. Cleared by user code to disable watchdog mode.
4		Secure Clear Bit. Set by user to use the secure clear option. Cleared by user to disable the secure clear option by default.
3:2		Timer3 Clock (32.768 kHz) Prescaler.
	00	Source Clock/1 (Default).
	01	Reserved.
	10	Reserved.
	11	Reserved.
1		Watchdog Timer IRQ Enable. Set by user code to produce an IRQ instead of a reset when the watchdog reaches 0. Cleared by user code to disable the IRQ option.
0		PD_OFF. Set by user code to stop Timer3 when the peripherals are powered down via Bit 4 in the POWCON MMR. Cleared by user code to enable Timer3 when the peripherals are powered down via Bit 4 in the POWCON MMR.

Secure Clear Bit (Watchdog Mode Only)

The secure clear bit is provided for a higher level of protection. When set, a specific sequential value must be written to T3ICLR to avoid a watchdog reset. The value is a sequence generated by the 8-bit linear feedback shift register (LFSR) polynomial equal to $X^8 + X^6 + X^5 + X + 1$, as shown in Figure 59.

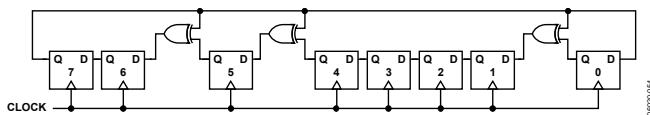

Figure 59. 8-Bit LFSR

The initial value or seed is written to T3ICLR before entering watchdog mode. After entering watchdog mode, a write to T3ICLR must match this expected value. If it matches, the LFSR is advanced to the next state when the counter reload happens. If it fails to match the expected state, reset is immediately generated, even if the count has not yet expired.

The value 0x00 should not be used as an initial seed due to the properties of the polynomial. The value 0x00 is always guaranteed to force an immediate reset. The value of the LFSR cannot be read; it must be tracked/generated in software.

The following is an example of a sequence:

1. Enter initial seed, 0 xAA, in T3ICLR before starting Timer3 in watchdog mode.
2. Enter 0 xAA in T3ICLR; Timer3 is reloaded.
3. Enter 0x37 in T3ICLR; Timer3 is reloaded.
4. Enter 0x6E in T3ICLR; Timer3 is reloaded.
5. Enter 0x66. 0xDC was expected; the watchdog resets the chip.

TIMER4—GENERAL-PURPOSE TIMER

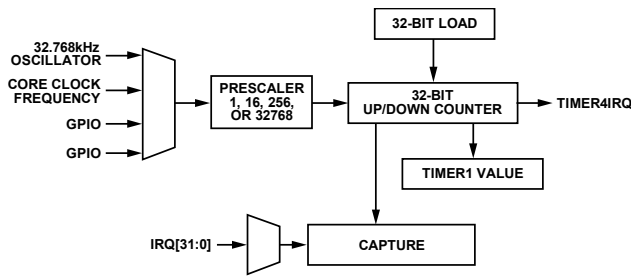

Figure 60. Timer4 Block Diagram

Timer4 is a 32-bit, general-purpose count down or count up timer with a programmable prescaler. The prescaler source can be the 32 kHz oscillator, the core clock, or one of two external GPIOs. This source can be scaled by a factor of 1, 16, 256, or 32,768. This gives a minimum resolution of 42 ns when operating at CD zero, the core is operating at 41.78 MHz, and with a prescaler of 1 (ignoring external GPIO).

The counter can be formatted as a standard 32-bit value or as hours:minutes:seconds:hundredths.

Timer4 has a capture register (T4CAP), which can be triggered by a selected IRQ source initial assertion. Once triggered, the current timer value is copied to T4CAP, and the timer keeps running. This feature can be used to determine the assertion of an event with increased accuracy.

The Timer4 interface consists of five MMRs.

Table 116. Timer4 Interface MMRs

Name	Description
T4LD	A 32-bit register. Holds 32-bit unsigned integers.
T4VAL	A 32-bit register. Holds 32-bit unsigned integers. This register is read only.
T4CAP	A 32-bit register. Holds 32-bit unsigned integers. This register is read only.
T4ICLR	An 8-bit register. Writing any value to this register clears the Timer1 interrupt.
T4CON	The configuration MMR (see Table 117).

Note that if the part is in a low power mode and Timer4 is clocked from the GPIO or oscillator source, Timer4 continues to operate.

Timer4 reloads the value from T4LD either when Timer 4 overflows, or immediately when T4ICLR is written.

Timer4 Load Register

Name	Address	Default Value	Access
T4LD	0xFFFF0380	0x00000	R/W

T4LD is a 32-bit register that holds the 32-bit value that is loaded into the counter.

Timer4 Clear Register

Name	Address	Default Value	Access
T4ICLR	0xFFFF038C	0x00	W

This 8-bit, write only MMR is written (with any value) by user code to refresh (reload) Timer4.

Timer4 Value Register

Name	Address	Default Value	Access
T4VAL	0xFFFF0384	0x0000	R

T4VAL is a 32-bit register that holds the current value of Timer4.

Timer4 Capture Register

Name	Address	Default Value	Access
T4CAP	0xFFFF0390	0x00	R

This is a 32-bit register that holds the 32-bit value captured by an enabled IRQ event.

Timer4 Control Register

Name	Address	Default Value	Access
T4CON	0xFFFF0388	0x0000	R/W

This 32-bit MMR configures the mode of operation of Timer4.

ADuC7128/ADuC7129

Table 117. T4CON MMR Bit Designations

Bit	Value	Description
31:18		Reserved. Set by user to 0.
17		Event Select Bit. Set by user to enable time capture of an event. Cleared by user to disable time capture of an event.
16:12		Event Select Range, 0 to 31. The events are as described in the Timers section.
11:9	000 001 010 011	Clock Select. Core Clock (Default). 32.768 kHz Oscillator. P4.6. P4.7.
8		Count Up. Set by user for Timer4 to count up. Cleared by user for Timer4 to count down (default).
7		Timer4 Enable Bit. Set by user to enable Timer4. Cleared by user to disable Timer4 (default).
6		Timer4 Mode. Set by user to operate in periodic mode. Cleared by user to operate in free-running mode (default).
5:4	00 01 10 11	Format. Binary (Default). Reserved. Hours:Minutes:Seconds:Hundredths: 23 Hours to 0 Hours. Hours:Minutes:Seconds:Hundredths: 255 Hours to 0 Hours.
3:0	0000 0100 1000 1111	Prescaler. Source Clock/1 (Default). Source Clock/16. Source Clock/256. Source Clock/32,768.

EXTERNAL MEMORY INTERFACING

The ADuC7129 is the only model in the series that features an external memory interface. The external memory interface requires a larger number of pins. This is why it is only available on larger pin count packages. The XMCFG MMR must be set to 1 to use the external port.

Although 32-bit addresses are supported internally, only the lower 16 bits of the address are on external pins.

The memory interface can address up to four 128 kB regions of asynchronous memory (SRAM and/or EEPROM).

The pins required for interfacing to an external memory are shown in Table 118.

Table 118. External Memory Interfacing Pins

Pin	Function
AD[15:0]	Address/Data Bus.
A16	Extended Addressing for 8-Bit Memory Only.
MS[3:0]	Memory Select.
WR (\overline{WR})	Write Strobe.
RS (\overline{RS})	Read Strobe.
AE	Address Latch Enable.
BHE, \overline{BLE}	Byte Write Capability.

There are four external memory regions available, as described in Table 119. Associated with each region are the MS[3:0] pins. These signals allow access to the particular region of external memory. The size of each memory region can be 128 kB maximum, 64 k × 16, or 128 k × 8. To access 128 kB with an 8-bit memory, an extra address line (A16) is provided. (See the example in Figure 61). The four regions are configured independently.

Table 119. Memory Regions

Address Start	Address End	Contents
0x10000000	0x1000FFFF	External Memory 0
0x20000000	0x2000FFFF	External Memory 1
0x30000000	0x3000FFFF	External Memory 2
0x40000000	0x4000FFFF	External Memory 3

Each external memory region can be controlled through three MMRs: XMCFG, XMxCON, and XMxPAR.

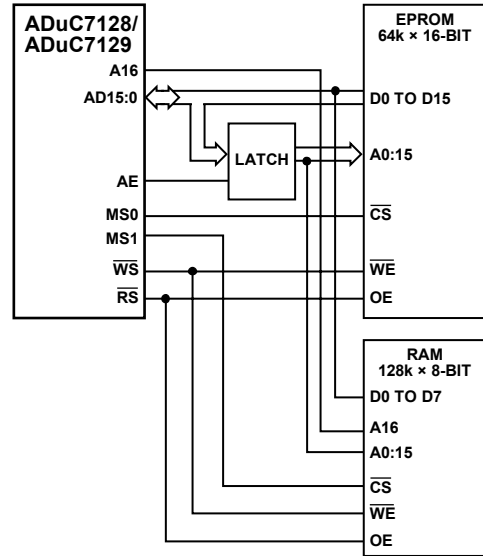

Figure 61. Interfacing to External EPROM/RAM

XMCFG Register

Name	Address	Default Value	Access
XMCFG	0xFFFFF000	0x00	R/W

XMCFG is set to 1 to enable external memory access. This must be set to 1 before any port pins function as external memory access pins. The port pins must also be individually enabled via the GPxCON MMR.

XMxCON Registers

Name	Address	Default Value	Access
XM0CON	0xFFFFF010	0x00	R/W
XM1CON	0xFFFFF014	0x00	R/W
XM2CON	0xFFFFF018	0x00	R/W
XM3CON	0xFFFFF01C	0x00	R/W

XMxCON registers are the control registers for each memory region. They allow the enabling/disabling of a memory region and control the data bus width of the memory region.

Table 120. XMxCON MMR Bit Designations

Bit	Description
1	Data Bus Width Select. Set by the user to select a 16-bit data bus. Cleared by the user to select an 8-bit data bus.
0	Memory Region Enable. Set by the user to enable memory region. Cleared by the user to disable the memory region.

XMxPAR Registers

Name	Address	Default Value	Access
XM0PAR	0xFFFFF020	0x70FF	R/W
XM1PAR	0xFFFFF024	0x70FF	R/W
XM2PAR	0xFFFFF028	0x70FF	R/W
XM3PAR	0xFFFFF02C	0x70FF	R/W

ADuC7128/ADuC7129

The XMxPAR are registers that define the protocol used for accessing the external memory for each memory region.

Table 121. XMxPAR MMR Bit Designations

Bit	Description
15	Enable Byte Write Strobe. This bit is only used for two, 8-bit memory sharing the same memory region. Set by user to gate the AD0 output with the WS output. This allows byte write capability without using $\overline{\text{BHE}}$ and $\overline{\text{BLE}}$ signals. Cleared by user to use $\overline{\text{BHE}}$ and $\overline{\text{BLE}}$ signals.
14:12	Number of Wait States on the Address Latch Enable Strobe.
11	Reserved.
10	Extra Address Hold Time. Set by the user to disable extra hold time. Cleared by the user to enable one clock cycle of hold on the address in read and write.
9	Extra Bus Transition Time on Read. Set by the user to disable extra bus transition time. Cleared by the user to enable one extra clock before and after the read select ($\overline{\text{RS}}$).
8	Extra Bus Transition Time on Write. Set by the user to disable extra bus transition time. Cleared by the user to enable one extra clock before and after the write select ($\overline{\text{WS}}$).
7:4	Number of Write Wait States. Select the number of wait states added to the length of the $\overline{\text{WS}}$ pulse. 0x0 is 1 clock cycle; 0xF is 16 clock cycles (default value).
3:0	Number of Read Wait States. Select the number of wait states added to the length of the $\overline{\text{RS}}$ pulse. 0x0 is 1 clock cycle; 0xF is 16 clock cycles (default value).

TIMING DIAGRAMS

Figure 62 through Figure 65 show the timing for a read cycle (see Figure 62), a read cycle with address hold and bus turn cycles (see Figure 63), a write cycle with address hold and write hold cycles (see Figure 64), and a write cycle with wait states (see Figure 65).

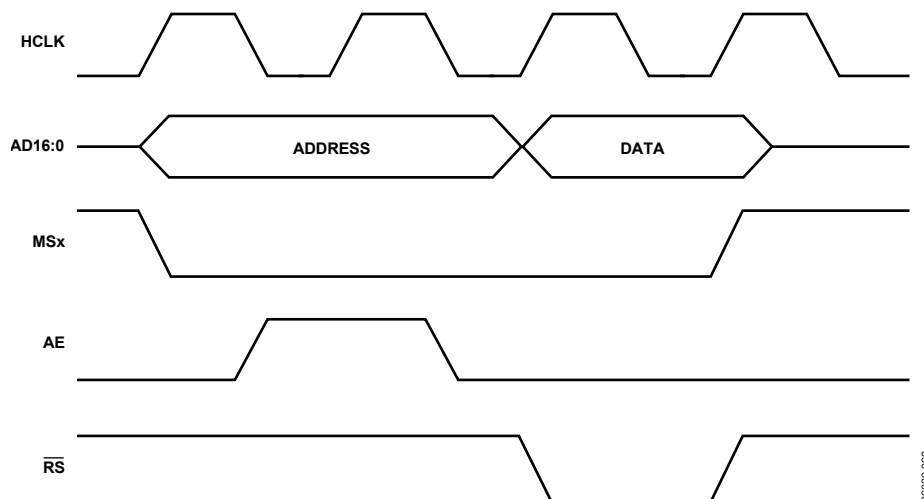

Figure 62. External Memory Read Cycle



Figure 63. External Memory Read Cycle with Address Hold and Bus Turn Cycles



Figure 64. External Memory Write Cycle with Address Hold and Write Hold Cycles



Figure 65. External Memory Write Cycle with Wait States

06020-1072

HARDWARE DESIGN CONSIDERATIONS

POWER SUPPLIES

The ADuC7128/ADuC7129 operational power supply voltage range is 3.0 V to 3.6 V. Separate analog and digital power supply pins (AV_{DD} and IOV_{DD} , respectively) allow AV_{DD} to be kept relatively free of noisy digital signals often present on the system IOV_{DD} line. In this mode, the part can also operate with split supplies, that is, using different voltage supply levels for each supply. For example, the system can be designed to operate with an IOV_{DD} voltage level of 3.3 V while the AV_{DD} level can be at 3 V, or vice versa, if required. A typical split supply configuration is shown in Figure 66.

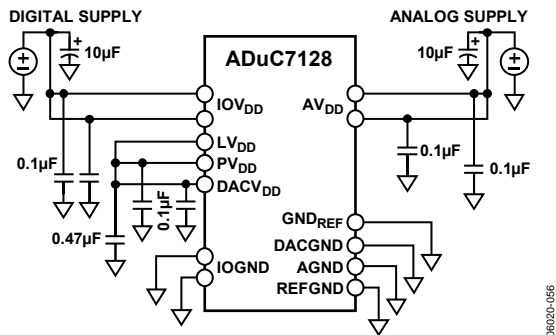

Figure 66. External Dual Supply Connections

As an alternative to providing two separate power supplies, the user can help keep AV_{DD} quiet by placing a small series resistor and/or ferrite bead between AV_{DD} and IOV_{DD} , and then decoupling AV_{DD} separately to ground. An example of this configuration is shown in Figure 67. With this configuration, other analog circuitry (such as op amps or voltage references) can be powered from the AV_{DD} supply line as well.



Figure 67. External Single Supply Connections

Note that in both Figure 66 and Figure 67, a large value (10 μ F) reservoir capacitor sits on IOV_{DD} and a separate 10 μ F capacitor sits on AV_{DD} . In addition, local small value (0.1 μ F) capacitors are located at each AV_{DD} and IOV_{DD} pin of the chip. As per standard design practice, be sure to include all of these capacitors and ensure that the smaller capacitors are close to each AV_{DD} pin with trace lengths as short as possible.

Connect the ground terminal of each of these capacitors directly to the underlying ground plane. It should also be noted that, at all times, the analog and digital ground pins on the ADuC7128/ADuC7129 must be referenced to the same system ground reference point.

Finally, on the LFCSP package, the paddle on the bottom of the package should be soldered to a metal plate to provide mechanical stability. The metal plate should be connected to ground.

Linear Voltage Regulator

The ADuC7128/ADuC7129 require a single 3.3 V supply, but the core logic requires a 2.5 V supply. An on-chip linear regulator generates the 2.5 V from IOV_{DD} for the core logic. The LV_{DD} pin is the 2.5 V supply for the core logic. The DAC logic and PLL logic also require a 2.5 V supply that must be connected externally from the LV_{DD} pin to the $DACV_{DD}$ pin and the PV_{DD} pin. An external compensation capacitor of 0.47 μ F must be connected between LV_{DD} and DGND (as close as possible to these pins) to act as a tank of charge, as shown in Figure 68. In addition, decoupling capacitors of 0.1 μ F must be placed as close as possible to the PV_{DD} pin and the $DACV_{DD}$ pin.

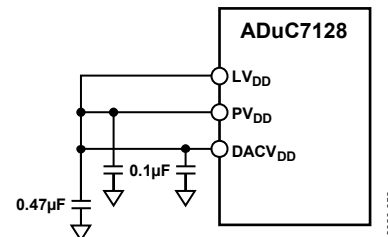

Figure 68. Voltage Regulator Connections

The LV_{DD} pin should not be used for any other chip. It is also recommended that the IOV_{DD} have excellent power supply decoupling to help improve line regulation performance of the on-chip voltage regulator.

GROUNDING AND BOARD LAYOUT RECOMMENDATIONS

As with all high resolution data converters, special attention must be paid to grounding and PC board layout of the design to achieve optimum performance from the ADCs and DAC.

Although the ADuC7128/ADuC7129 have separate pins for analog and digital ground (AGND and IOGND), the user must not tie these to two separate ground planes unless the two ground planes are connected together very close to the ADuC7128/ADuC7129, as illustrated in the simplified example of Figure 69a. In systems where digital and analog ground planes are connected together somewhere else (for example, at the system power supply), they cannot be connected again near the ADuC7128/ADuC7129 because a ground loop results.

ADuC7128/ADuC7129

In these cases, tie the AGND pins and IOGND pins of the ADuC7128/ADuC7129 to the analog ground plane, as shown in Figure 69b. In systems with only one ground plane, ensure that the digital and analog components are physically separated onto separate halves of the board such that digital return currents do not flow near analog circuitry and vice versa. The ADuC7128/ADuC7129 can then be placed between the digital and analog sections, as illustrated in Figure 69c.

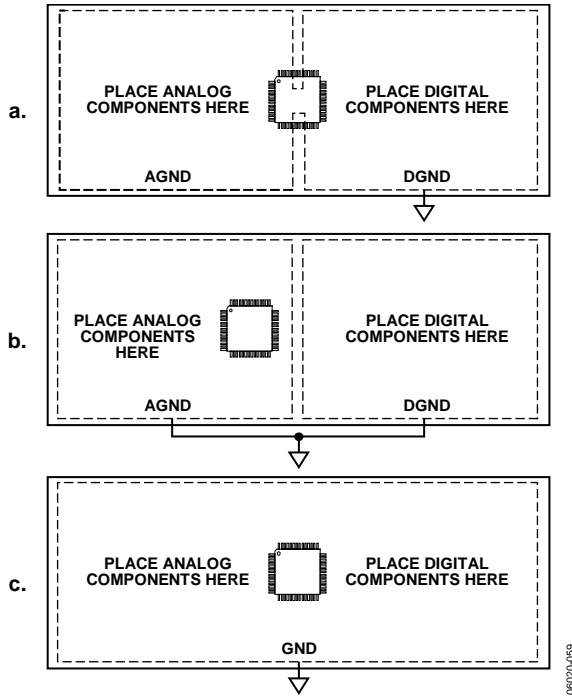

Figure 69. System Grounding Schemes

In all of these scenarios, and in more complicated real-life applications, keep in mind the flow of current from the supplies and back to ground. Make sure the return paths for all currents are as close as possible to the paths the currents took to reach their destinations. For example, do not power components on the analog side (see Figure 69b) with IOV_{DD} since that would force return currents from IOV_{DD} to flow through AGND. Avoid digital currents from flowing under analog circuitry, which could happen if the user places a noisy digital chip on the left half of the board (see Figure 69c). Whenever possible, avoid large discontinuities in the ground planes (such as are formed by a long trace on the same layer) because they force return signals to travel a longer path. Make all connections to the ground plane directly, with little or no trace separating the pin from its via to ground.

If a user plans to connect fast logic signals (rise/fall time < 5 ns) to any of the digital inputs of the ADuC7128/ADuC7129, add a series resistor to each relevant line to keep rise and fall times longer than 5 ns at the ADuC7128/ADuC7129 input pins.

A value of 100 Ω or 200 Ω is usually sufficient to prevent high speed signals from coupling capacitively into the ADuC7128/ADuC7129 and affecting the accuracy of ADC conversions.

CLOCK OSCILLATOR

The clock source for the ADuC7128/ADuC7129 can be generated by the internal PLL or by an external clock input. To use the internal PLL, connect a 32.768 kHz parallel resonant crystal between XCLKI and XCLKO as shown Figure 70. External capacitors should be connected as per the crystal manufacturer's recommendations. Note that the crystal pads already have an internal capacitance of typically 10 pF. Users should ensure that the total capacitance (10 pF internal + external capacitance) does not exceed the manufacturer rating.

The 32 kHz crystal allows the PLL to lock correctly to give a frequency of 41.78 MHz. If no external crystal is present, the internal oscillator is used to give a frequency of 41.78 MHz ± 3% typically.



Figure 70. External Parallel Resonant Crystal Connections

To use an external source clock input instead of the PLL, Bit 1 and Bit 0 of PLLCON must be modified. The external clock uses the XCLK pin.

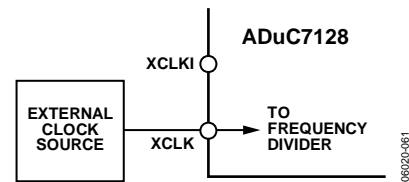

Figure 71. Connecting an External Clock Source

Whether using the internal PLL or an external clock source, the specified operational clock speed range of the ADuC7128/ADuC7129 is 50 kHz to 41.78 MHz to ensure correct operation of the analog peripherals and Flash/EE.

POWER-ON RESET OPERATION

An internal power-on reset (POR) is implemented on the ADuC7128/ADuC7129. For LV_{DD} below 2.45 V, the internal POR holds the ADuC7128/ADuC7129 in reset. As LV_{DD} rises above 2.45 V, an internal timer times out for typically 64 ms before the part is released from reset. The user must ensure that the power supply, IOV_{DD} , has reached a stable 3.0 V minimum level by this time. On power-down, the internal POR holds the ADuC7128/ADuC7129 in reset until LV_{DD} has dropped below 2.45 V. Figure 72 illustrates the operation of the internal POR in detail.

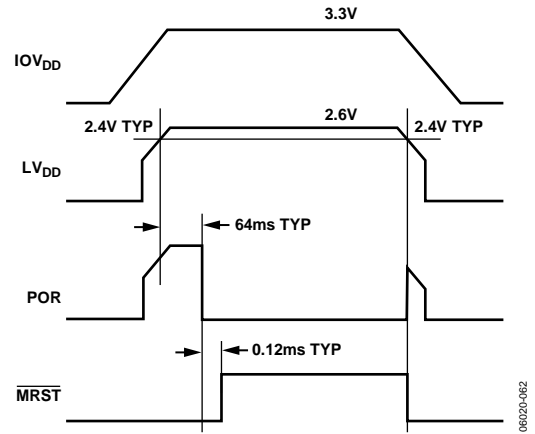

Figure 72. Internal Power-On Reset Operation

06/020-062

DEVELOPMENT TOOLS

An entry level, low cost development system is available for the ADuC7128/ADuC7129. This system consists of the following PC-based (Windows® compatible) hardware and software development tools.

Hardware

- ADuC7128/ADuC7129 evaluation board
- Serial port programming cable
- JTAG emulator

Software

- Integrated development environment, incorporating assembler, compiler, and nonintrusive JTAG-based debugger
- Serial downloader software
- Example code

Miscellaneous

- CD-ROM documentation

IN-CIRCUIT SERIAL DOWNLOADER

The serial downloader is a Windows application that allows the user to serially download an assembled program to the on-chip program Flash/EE memory via the serial port on a standard PC.

OUTLINE DIMENSIONS



*COMPLIANT TO JEDEC STANDARDS MO-220-VMM4 EXCEPT FOR EXPOSED PAD DIMENSION

Figure 73. 64-Lead Lead Frame Chip Scale Package [LFCSP_VQ]
9 mm x 9 mm Body, Very Thin Quad (CP-64-1)
Dimensions shown in millimeters

063006-B

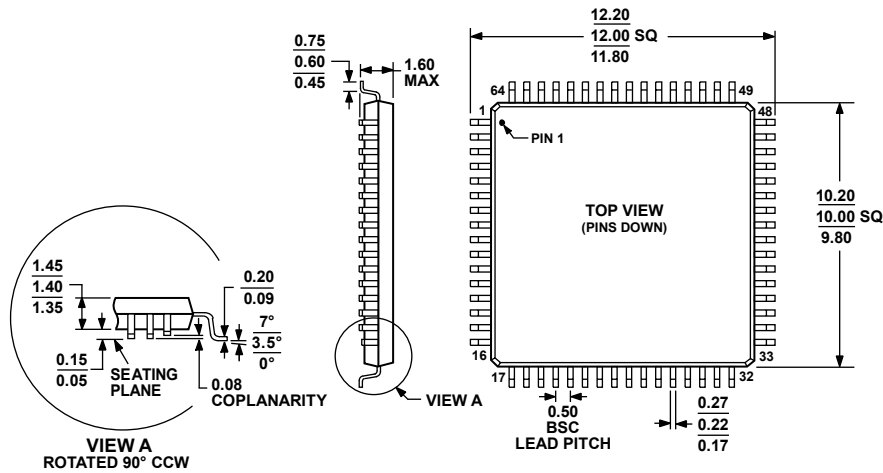

COMPLIANT TO JEDEC STANDARDS MS-026-BCD

Figure 74. 64-Lead Low Profile Quad Flat Package [LQFP] (ST-64-2)
Dimensions shown in millimeters

051706-A

ADuC7128/ADuC7129

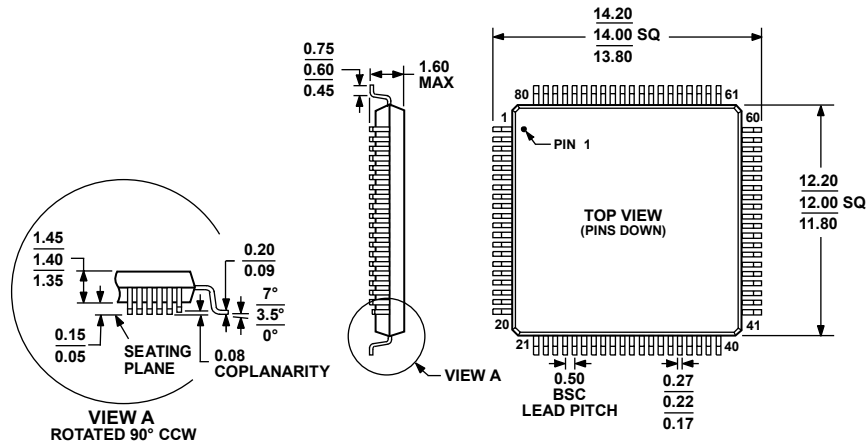

COMPLIANT TO JEDEC STANDARDS MS-026-BDD

Figure 75. 80-Lead Low Profile Quad Flat Package [LQFP] (ST-80-1)

Dimensions shown in millimeters

051706-A

ORDERING GUIDE

Model ¹	Temperature Range	Package Description	Package Option
ADUC7128BCPZ126 ²	-40°C to +125°C	64-Lead Lead Frame Chip Scale Package [LFCSP_VQ]	CP-64-1
ADUC7128BCPZ126-RL ²	-40°C to +125°C	64-Lead Lead Frame Chip Scale Package [LFCSP_VQ]	CP-64-1
ADUC7128BSTZ126 ²	-40°C to +125°C	64-Lead LQFP	ST-64-2
ADUC7128BSTZ126-RL ²	-40°C to +125°C	64-Lead LQFP	ST-64-2
ADUC7129BSTZ126 ²	-40°C to +125°C	80-Lead LQFP	ST-80-1
ADUC7129BSTZ126-RL ²	-40°C to +125°C	80-Lead LQFP	ST-80-1
EVAL-ADUC7128QSPZ ²		Evaluation Board	

¹ Reel quantities are 2,500 for the LFCSP and 1,000 for the LQFP.

² Z = RoHS Compliant Part.

Purchase of licensed I²C components of Analog Devices or one of its sublicensed Associated Companies conveys a license for the purchaser under the Philips I²C Patent Rights to use these components in an I²C system, provided that the system conforms to the I²C Standard Specification as defined by Philips.

Данный компонент на территории Российской Федерации

Вы можете приобрести в компании MosChip.

Для оперативного оформления запроса Вам необходимо перейти по данной ссылке:

<http://moschip.ru/get-element>

Вы можете разместить у нас заказ для любого Вашего проекта, будь то серийное производство или разработка единичного прибора.

В нашем ассортименте представлены ведущие мировые производители активных и пассивных электронных компонентов.

Нашей специализацией является поставка электронной компонентной базы двойного назначения, продукции таких производителей как XILINX, Intel (ex.ALTERA), Vicor, Microchip, Texas Instruments, Analog Devices, Mini-Circuits, Amphenol, Glenair.

Сотрудничество с глобальными дистрибьюторами электронных компонентов, предоставляет возможность заказывать и получать с международных складов практически любой перечень компонентов в оптимальные для Вас сроки.

На всех этапах разработки и производства наши партнеры могут получить квалифицированную поддержку опытных инженеров.

Система менеджмента качества компании отвечает требованиям в соответствии с ГОСТ Р ИСО 9001, ГОСТ РВ 0015-002 и ЭС РД 009

Офис по работе с юридическими лицами:

105318, г.Москва, ул.Щербаковская д.3, офис 1107, 1118, ДЦ «Щербаковский»

Телефон: +7 495 668-12-70 (многоканальный)

Факс: +7 495 668-12-70 (доб.304)

E-mail: info@moschip.ru

Skype отдела продаж:

moschip.ru

moschip.ru_4

moschip.ru_6

moschip.ru_9