

1. Features and Benefits

- High accuracy relative pressure sensor (+/-1.5%FSO)
- Ratiometric analog output or digital SENT output
- Fully integrated IC: MEMS, analog front end circuitry, 16 bit microcontroller, analog back end circuitry, voltage regulators
- Large automotive temperature range (-40°C to 150°C)
- Automotive qualified and automotive diagnostic features (clamping levels, broken track diagnostics, multiple internal fault diagnostics)
- Factory calibrated and/or fully programmable through the connector for customized calibration curves
- Back side exposed relative pressure sensor for higher resistance to common automotive media
- Assembled in a robust easy to seal package

2. Application Examples

- Automotive applications
 - Vacuum measurement
 - Clogged filter detection
 - Seat lumbar cushion sensor
- Industrial applications
 - Vacuum sensor
 - Process monitoring
 - Fluid pressure (low pressure/high accuracy)
- Consumer/Home appliance applications
 - Filter monitoring
 - Dispensing/metering systems
 - White goods

3. Ordering information

Part No.	Temperature Code	Package Code	Option Code	Packing Form Code
MLX90809	L (-40°C to 150°C)	XG	EAD-000	RE
MLX90809	L (-40°C to 150°C)	XG	EAD-003	RE
MLX90809	L (-40°C to 150°C)	XG	EAD-007	RE
MLX90809	L (-40°C to 150°C)	XG	EAD-100	RE

Option code legend: EAD-000 = 0.05 to -1.05 bar relative pressure / 0.5 to 4.5 V analog output
EAD-003 = 0 to 1 bar relative pressure / 0.5 to 4.5 V analog output
EAD-007 = 0 to -1 bar relative pressure / 0.5 to 4.5 V analog output
EAD-100 = 0.05 to -1.2 bar relative pressure / 193 to 3896 LSB SENT output

MLX90809

Relative Pressure Sensor

4. Functional Diagram

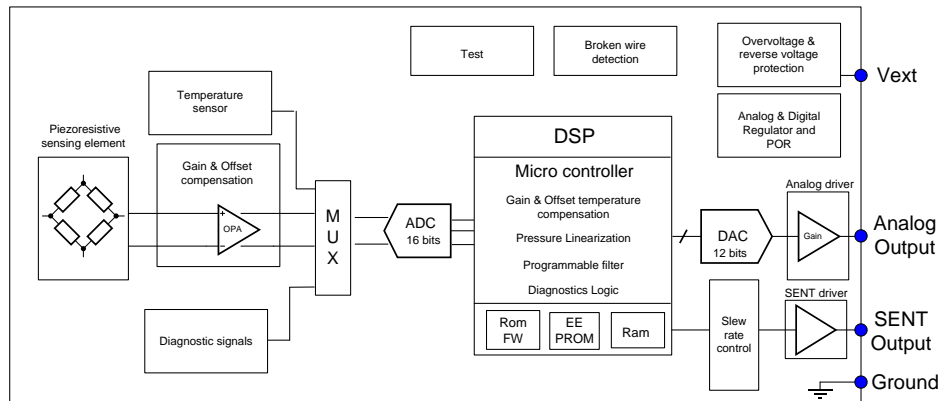

5. General Description

The MLX90809 is a packaged, factory calibrated, integrated relative pressure sensor delivering a ratiometric analog or digital (using the SENT protocol) signal.

Use of an optimized architecture and a high density CMOS technology imparts the MLX90809 with best in class automotive EMC performance. A DSP based architecture using a 16bit microcontroller provides outstanding performance.

A smart package and die assembly concept suits applications with stringent automotive temperature and stress conditions needing small drift over life.

6. Glossary of Terms

- Bar: Pressure unit (1bar = 100kPa)
- ADC: Analog to Digital Converter
- DAC: Digital to Analog Converter
- DSP: Digital Signal Processor
- EMC: Electro Magnetic Compatibility
- SENT: Single Edge Nibble Transmission
- FSO: Full Span Output

Contents

1. Features and Benefits	1
2. Application Examples	1
3. Ordering information	1
4. Functional Diagram	2
5. General Description	2
6. Glossary of Terms	2
7. Absolute Maximum Ratings	4
8. Pin Definitions and Descriptions	4
9. General Electrical Specifications	6
10. Detailed General Description	8
11. Programmed Settings	8
11.1. MLX90809LXG-EAD-000	9
11.2. MLX90809LXG-EAD-003	9
11.3. MLX90809LXG-EAD-007	10
11.4. MLX90809LXG-EAD-100	10
12. Application Information	12
13. Standard information regarding manufacturability of Melexis products with different soldering processes	13
14. ESD Precautions	13
15. Package Information	14
16. Contact	15
17. Disclaimer	15

7. Absolute Maximum Ratings

Exceeding the absolute maximum ratings may cause permanent damage. Exposure to absolute-maximum-rated conditions for extended periods may affect device reliability.

Parameter	Remarks	Value	Units
Supply Voltage (overvoltage)	Remark 1	18	V
Reverse Voltage Protection	Remark 2	-14	V
Positive output voltage	Remark 1	18	V
Reverse output voltage	Remark 1	-0.5	V
Operating Temperature Range		-40 to 150	°C
Storage Temperature Range		-40 to 150	°C
Burst pressure (Room Temperature) (AEC Q100 002)		5	Bar

Table 1: Absolute maximum ratings

Remark 1: No time limit or temperature limit for these over voltage conditions.

Remark 2: Reverse Voltage Protection at -14V at 150°C for maximum 1 hour. At Room Temperature that condition can apply for maximum 24 hours.

8. Pin Definitions and Descriptions

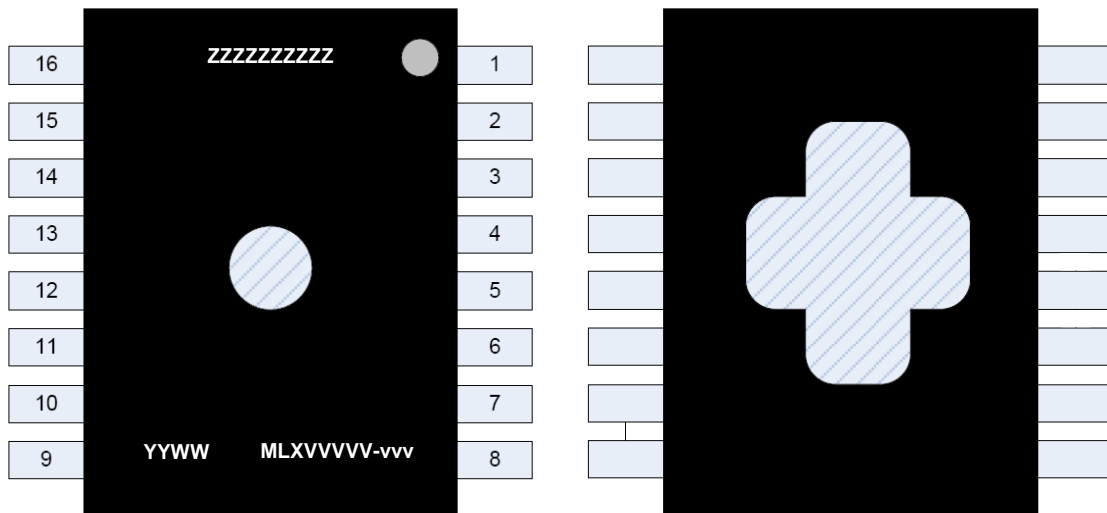

Figure 1: Package marking and pin out (Top view: left; Bottom view: right)

Pin number	Description	Pin number	Description
1	SENT output	16	SENT output
2	SENT output	15	SENT output
3	Supply Input	14	Supply Input
4	Test pin	13	Test pin
5	Not connected	12	Not connected
6	Ground	11	Ground
7	Analog output	10	Analog output
8	Analog output	9	Analog output

Table 2: Pin out definitions and descriptions

Only one of the application pins needs to be connected: one of the Supply Input pins (3 or 14), one of the Ground pins (6 or 11) and one of the selected (either analog (7,8,9,10) or SENT(1,2,15,16)) output pins. See section 9 for the detailed information on the application pins connections.

Symbol	Function / Description
VVVVV-vvv	Device used- design revision
YY	Year of assembly
WW	Calendar week of assembly
ZZZZZZZZZZ	Wafer lot number

Table 3: Package label definition

9. General Electrical Specifications

DC Operating Parameters $T_A = -40^{\circ}\text{C}$ to 150°C , $V_{DD} = 5\text{V}$ (unless otherwise specified).

Parameter	Symbol	Remarks	Min	Typ	Max	Units
Nominal supply voltage	Vdd		4.5	5	5.5	V
Nominal supply current	Idd	No output load connected		7	8	mA
Analog Output Load (Resistive)	Rload	Pull up or Pull down	4.7			kOhm
Analog Output Load (Capacitive)	Cload		2.2		470	nF
SENT Output Load (Capacitive)	Cload				2.2	nF
SENT Output Load (C-R-C)	CRCload				1.1nF + 220Ohm + 1.1nF	
Diagnostic limits	Diag low	Pull-up $\geq 4.7\text{k}\Omega$ Pull-down $\geq 4.7\text{k}\Omega$			3 3	%Vdd
	Diag high	Pull-up $\geq 4.7\text{k}\Omega$ Pull-down $\geq 8\text{k}\Omega$	96 96			%Vdd
Clamping levels	Clamp low	Programmable range with 8 bit resolution for the low clamping level, 9 for the high (for the default programmed levels see section 8), +/-10mV accuracy on the programmed clamping level	0		25	%Vdd
	Clamp high		50		100	%Vdd
Analog saturation output level	Vsat high	Pull-up $\geq 4.7\text{k}\Omega$ Pull-down $\geq 4.7\text{k}\Omega$ Pull-down $\geq 10\text{k}\Omega$	97		100	%Vdd
			96		100	
97				100		
Vsat low	Pull-up $\geq 4.7\text{k}\Omega$ Pull-down $\geq 4.7\text{k}\Omega$	0		3	%Vdd	
		0		3		
Power up time		Time from reaching minimum allowed supply voltage of 4.5V till having the output within specification			5.5	msec
Response time Analog Output		Time needed for the output to react to a pressure change from 10% to 90% of its final value (pressure change corresponding to maximum a 4V output change). Using default filter settings SSF = 1, PFLT = 0.			1	msec
Response time SENT Output				3	4	frames
Programmable pressure spans (Positive pressure on package top side, see remark 3, 5)		The pressure spans defined correspond to an analog output span of 4V or to the 12 bit pressure information on the SENT output	0.5		1	bar Relative
Programmable pressure spans (vacuum on package top side, see remark 3,5)		The pressure spans defined correspond to an analog output span of 4V or to the 12 bit pressure information on the SENT output	Remark 4		-0.5	bar Relative
Overall accuracy		Taking into account the drifts over temperature and over life			1.5	%FSO

Relative Pressure Sensor

Ratiometricity error				0.2	%Vdd
Output noise analog output		BW limited to 50kHz. Using default filter settings SSF = 1, PFLT = 0.		2	mVrms
Output noise SENT output		BW limited to 50kHz. Using default filter settings SSF = 1, PFLT = 0.		1.8	LSBrms
Internal Temperature Error on SENT Output	Tptat	0 hours	-5	5	°C
		Over life	-10	10	

Table 4: Electrical specifications

Remark 3: The top side of the package is defined as the side with the small hole and readable marking.

Remark 4: There are no limitations on the vacuum level that the MLX90809 can measure.

Remark 5: The pressure span is defined as being equal to UPL-LPL (upper pressure limit minus lower pressure limit like described for the default calibrated curve in paragraph 8). The atmospheric pressure should always belong to the programmed transfer function.

10. Detailed General Description

The pressure sensing element consists of a square diaphragm realized in the silicon chip by backside etching. The diaphragm reacts to a pressure difference between the top and bottom side of the diaphragm. The internal strain increases, in particular at the border of the diaphragm. Here, the piezo-resistive elements have been implanted into the silicon diaphragm, which act as a transducer.

The electronics front end amplifies the signal from the bridge, performs a coarse offset compensation and an ADC conversion. The DSP performs the compensations over temperature. Furthermore, the digital circuit provides some filtering, the possibility to linearize the pressure signal and also implements the clamping function. The analog back end consists of a 12 bit DAC and an output driver. This chip delivers an analog output proportional to the pressure or a SENT output compliant with SAE J2716 spec dated January 2010.

A broken wire detection block allows actively driving the output to one of the rails in case of a broken supply or ground connection. Extensive protection of the supply lines allows the MLX90809 to handle extreme overvoltage conditions and is immune to severe external disturbances. Several diagnostic functions (over-voltage, under-voltage, overpressure, under pressure detections) have been implemented on the 90809 and can be enabled by programming EEPROM settings. Figure 2 describes MLX90809 block diagram.

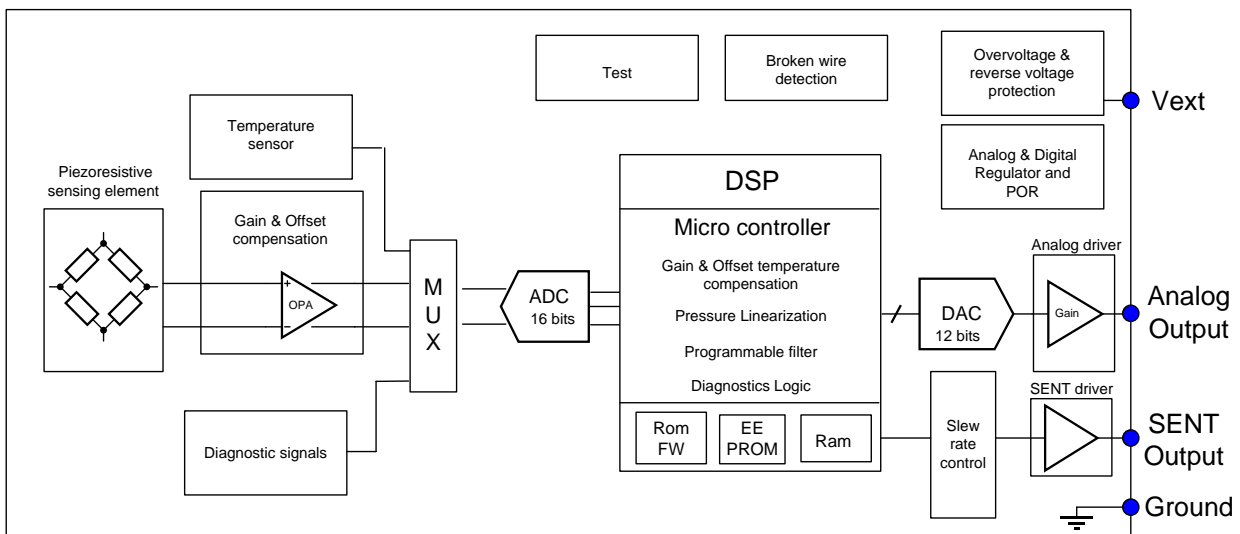

Figure 2: MLX90809 block diagram

11. Programmed Settings

The MLX90809 is calibrated at the final manufacturing test step. During the calibration, settings are stored in the on chip (16x32bit) EEPROM to define the pressure transfer curve as well as the output clamping levels. Together with the transfer functions, the IC filter values are set. The default programmed filter settings lead to the noise level and response times described in paragraph 6. The transfer functions calibrated in the different MLX90809LXG-EAD-xxx products with its corresponding performance level maintained over the full temperature range and over life is described for each specific option code below.

The MLX90809 can be programmed for pressure spans like those described in paragraph 6 with the atmospheric pressure always inside of the application range.

Relative Pressure Sensor

Contact Melexis for information on the expected accuracy for other ranges or transfer functions than the default programmed ones.

Melexis can support customers delivering parts calibrated with other settings or can support customers by delivering the necessary programming hardware, software and documentation to be able to program the transfer function on the customers manufacturing line. To learn how to use the Melexis hardware and software to program the MLX90809 read the application note “MLX90809 PTC04 Software Description”.

11.1. MLX90809LXG-EAD-000

DC Operating Parameters $T_A = -40^{\circ}\text{C}$ to 150°C , $V_{DD} = 5\text{V}$.

Parameter	Symbol	Remarks	Value			Unit
Pressure 1	P1	Transfer curve: Figure 3	0.05			Bar
Pressure 2	P2		-1.05			Bar
Output 1	O1		0.5			V
Output 2	O2		4.5			V
Parameter	Symbol	Remarks	Min	Typ	Max	Unit
Low clamping level	LCL		0.49	0.5	0.51	V
High clamping level	HCL		4.49	4.5	4.51	V
Output accuracy	ϵ_o	Overall accuracy expressed as output value	-60		60	mV
Pressure accuracy	ϵ_p	Overall accuracy expressed as pressure value	-16.5		16.5	mBar

11.2. MLX90809LXG-EAD-003

DC Operating Parameters $T_A = -40^{\circ}\text{C}$ to 150°C , $V_{DD} = 5\text{V}$.

Parameter	Symbol	Remarks	Value			Unit
Pressure 1	P1	Transfer curve: Figure 4	0			Bar
Pressure 2	P2		1			Bar
Output 1	O1		0.5			V
Output 2	O2		4.5			V
Parameter	Symbol	Remarks	Min	Typ	Max	Unit
Low clamping level	LCL		0.49	0.5	0.51	V
High clamping level	HCL		4.49	4.5	4.51	V
Output accuracy	ϵ_o	Overall accuracy expressed as output value	-60		60	mV
Pressure accuracy	ϵ_p	Overall accuracy expressed as pressure value	-15		15	mBar

11.3. MLX90809LXG-EAD-007

DC Operating Parameters $T_A = -40^{\circ}\text{C}$ to 150°C , $V_{DD} = 5\text{V}$.

Parameter	Symbol	Remarks	Value			Unit
Pressure 1	P1	Transfer curve: Figure 3	0			Bar
Pressure 2	P2		-1			Bar
Output 1	O1		0.5			V
Output 2	O2		4.5			V
Parameter	Symbol	Remarks	Min	Typ	Max	Unit
Low clamping level	LCL		0.25	0.3	0.35	V
High clamping level	HCL		4.75	4.8	4.85	V
Output accuracy	ϵ_o	Overall accuracy expressed as output value	-60		60	mV
Pressure accuracy	ϵ_p	Overall accuracy expressed as pressure value	-15		15	mBar

11.4. MLX90809LXG-EAD-100

DC Operating Parameters $T_A = -40^{\circ}\text{C}$ to 150°C , $V_{DD} = 5\text{V}$.

Parameter	Symbol	Remarks	Value			Unit
Pressure 1	P1	Transfer curve: Figure 3	0.05			Bar
Pressure 2	P2		-1.20			Bar
Output 1	O1		193			LSB
Output 2	O2		3896			LSB
Low clamping level	LCL		1			LSB
High clamping level	HCL		4088			LSB
Parameter	Symbol	Remarks	Min	Typ	Max	Unit
Output accuracy	ϵ_o	Overall accuracy expressed as output value	-60		60	LSB
Pressure accuracy	ϵ_p	Overall accuracy expressed as pressure value	-20		20	mBar

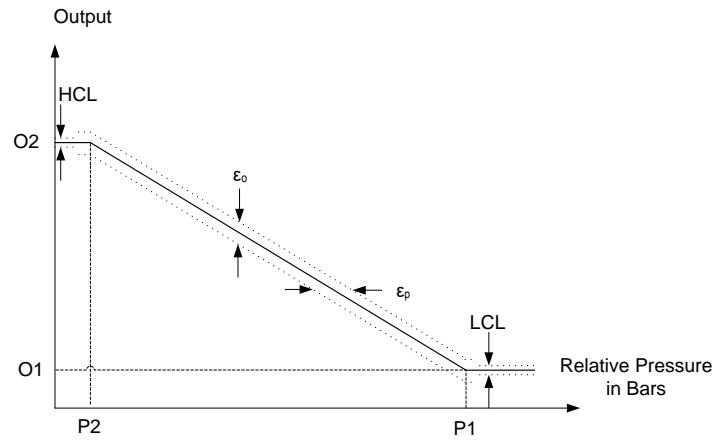

Figure 3: Transfer function negative pressure curve

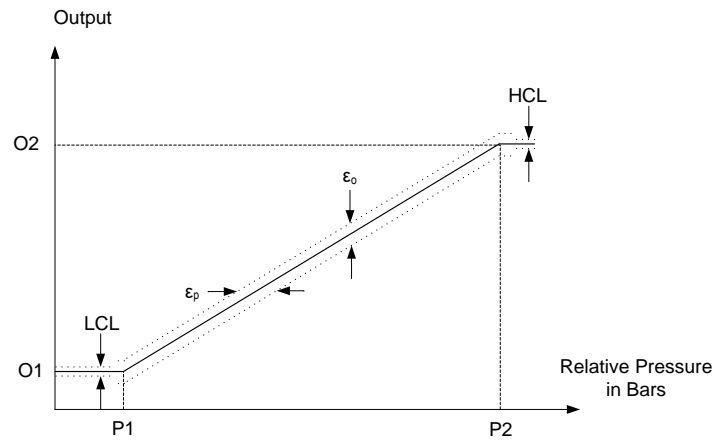

Figure 4: Transfer function positive pressure curve

12. Application Information

The MLX90809 only needs 2 capacitors in the application, a 47nF decoupling capacitor on the supply line and a 47nF load on the analog output pin. When the SENT output is used a 2.2nF capacitor is recommended.

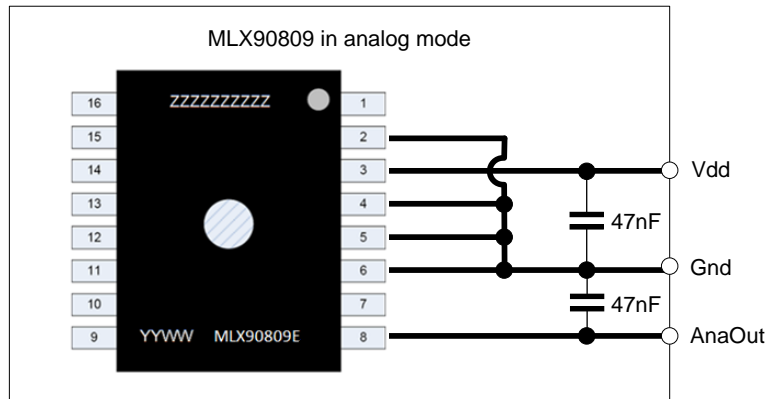

Figure 4: MLX90809 application schematic in analog mode

When using the analog output, Melexis recommends shorting one of the SENT output pins and the test pin to GND.

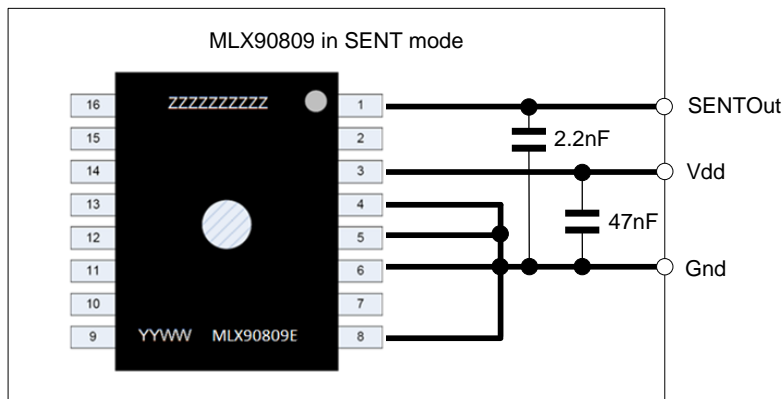

Figure 5: MLX90809 application schematic in SENT mode

When using the SENT output Melexis recommends shorting one of the analog output pins and the test pin to GND.

These recommendations for external components are however only providing a basic protection. Depending on the module design and the EMC specification requirements different configurations can be needed.

Read the application note “System Integration Guidelines” for manufacturing handling as well as sealing recommendations.

13. Standard information regarding manufacturability of Melexis products with different soldering processes

Our products are classified and qualified regarding soldering technology, solderability and moisture sensitivity level according to following test methods:

Reflow Soldering SMD's (Surface Mount Device)s)

- IPC/JEDEC J-STD-020
Moisture/Reflow Sensitivity Classification for Nonhermetic Solid State Surface Mount Devices (classification reflow profiles according to table 5-2)
- EIA/JEDEC JESD22-A113
Preconditioning of Nonhermetic Surface Mount Devices Prior to Reliability Testing (reflow profiles according to table 2)

Wave Soldering SMD's (Surface Mount Device)s) and THD's (Through Hole Device)s)

- EN60749-20
Resistance of plastic- encapsulated SMD's to combined effect of moisture and soldering heat
- EIA/JEDEC JESD22-B106 and EN60749-15
Resistance to soldering temperature for through-hole mounted devices

Iron Soldering THD's (Through Hole Device)s)

- EN60749-15
Resistance to soldering temperature for through-hole mounted devices

Solderability SMD's (Surface Mount Device)s) and THD's (Through Hole Device)s)

- EIA/JEDEC JESD22-B102 and EN60749-21
Solderability

For all soldering technologies deviating from above mentioned standard conditions (regarding peak temperature, temperature gradient, temperature profile etc) additional classification and qualification tests have to be agreed upon with Melexis.

The application of Wave Soldering for SMD's is allowed only after consulting Melexis regarding assurance of adhesive strength between device and board.

Melexis is contributing to global environmental conservation by promoting **lead free** solutions. For more information on qualifications of **RoHS** compliant products (RoHS = European directive on the Restriction Of the use of certain Hazardous Substances) please visit the quality page on our website:

<http://www.melexis.com/quality.aspx>

14. ESD Precautions

Electronic semiconductor products are sensitive to Electro Static Discharge (ESD). Always observe Electro Static Discharge control procedures whenever handling semiconductor products.

15. Package Information

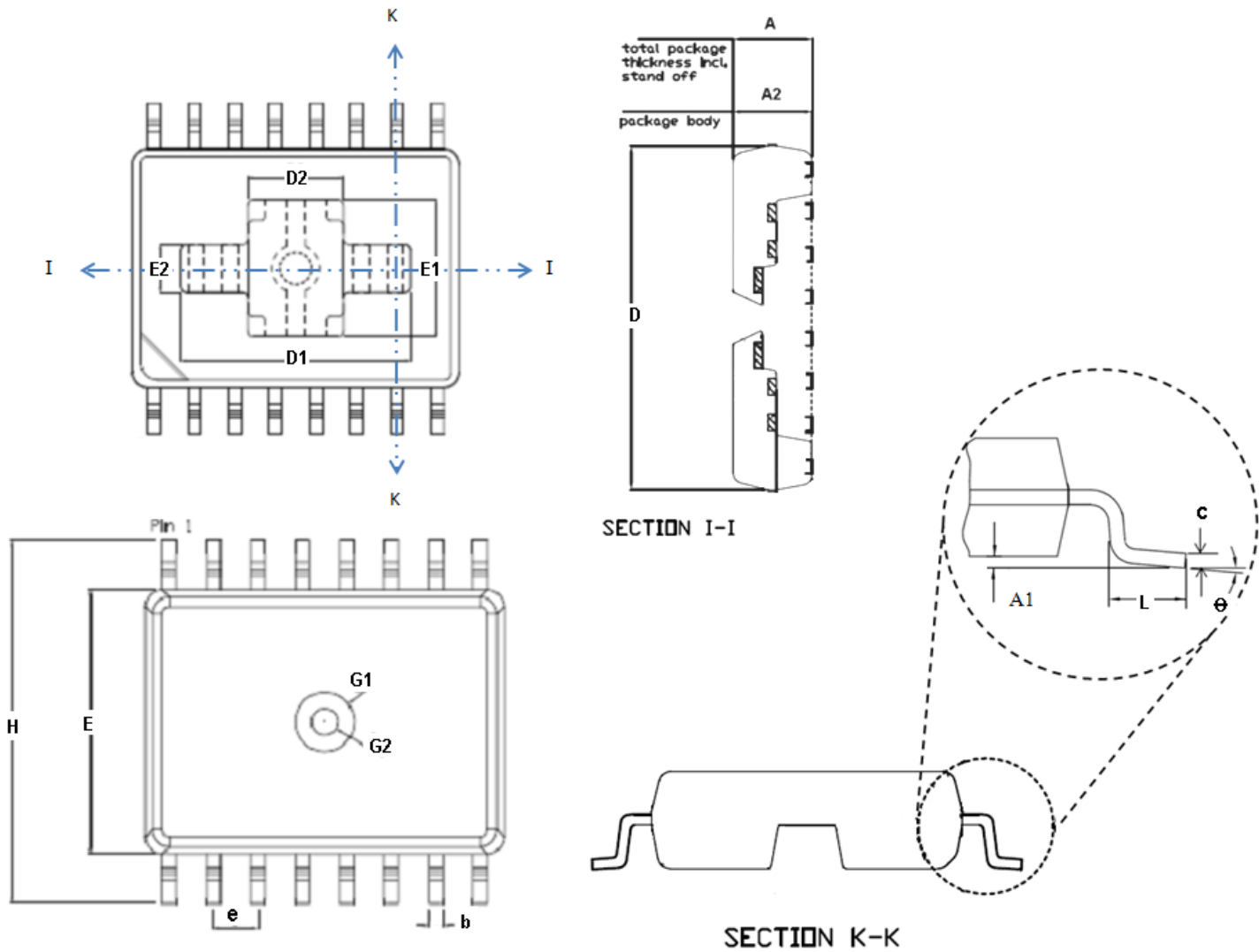

Figure 6: MLX90809 package drawing

Table in mm	A	A1	A2	D	D1	D2	E	E1	E2
min	2.28	-0.025	2.34	10.19	7.7	3.7	7.45	4.8	1.9
max	2.45	0.075	REF	10.33	8.1	4.1	7.59	5.2	2.3

A: total package thickness (body thickness + stand off)

A1: package stand off

Table in mm	α	c	H	e	B	L	G1	G2
min	0°	0.2	10.11	1.27	0.326	0.74	1.5	0.56
max	8°	0.33	10.51	BSC	0.486	0.99	1.7	0.96

Table 5: Detailed package dimensions

16. Contact

For the latest version of this document, go to our website at www.melexis.com.

For additional information, please contact our Direct Sales team and get help for your specific needs:

Europe, Africa	Telephone: +32 13 67 04 95
	Email : sales_europe@melexis.com
Americas	Telephone: +1 603 223 2362
	Email : sales_usa@melexis.com
Asia	Email : sales_asia@melexis.com

17. Disclaimer

The information furnished by Melexis herein ("Information") is believed to be correct and accurate. Melexis disclaims (i) any and all liability in connection with or arising out of the furnishing, performance or use of the technical data or use of the product(s) as described herein ("Product") (ii) any and all liability, including without limitation, special, consequential or incidental damages, and (iii) any and all warranties, express, statutory, implied, or by description, including warranties of fitness for particular purpose, non-infringement and merchantability. No obligation or liability shall arise or flow out of Melexis' rendering of technical or other services.

The Information is provided "as is" and Melexis reserves the right to change the Information at any time and without notice. Therefore, before placing orders and/or prior to designing the Product into a system, users or any third party should obtain the latest version of the relevant information to verify that the information being relied upon is current. Users or any third party must further determine the suitability of the Product for its application, including the level of reliability required and determine whether it is fit for a particular purpose.

The Information is proprietary and/or confidential information of Melexis and the use thereof or anything described by the Information does not grant, explicitly or implicitly, to any party any patent rights, licenses, or any other intellectual property rights.

This document as well as the Product(s) may be subject to export control regulations. Please be aware that export might require a prior authorization from competent authorities.

The Product(s) are intended for use in normal commercial applications. Unless otherwise agreed upon in writing, the Product(s) are not designed, authorized or warranted to be suitable in applications requiring extended temperature range and/or unusual environmental requirements. High reliability applications, such as medical life-support or life-sustaining equipment are specifically not recommended by Melexis.

The Product(s) may not be used for the following applications subject to export control regulations: the development, production, processing, operation, maintenance, storage, recognition or proliferation of 1) chemical, biological or nuclear weapons, or for the development, production, maintenance or storage of missiles for such weapons; 2) civil firearms, including spare parts or ammunition for such arms; 3) defense related products, or other material for military use or for law enforcement; 4) any applications that, alone or in combination with other goods, substances or organisms could cause serious harm to persons or goods and that can be used as a means of violence in an armed conflict or any similar violent situation.

The Products sold by Melexis are subject to the terms and conditions as specified in the Terms of Sale, which can be found at <https://www.melexis.com/en/legal/terms-and-conditions>.

This document supersedes and replaces all prior information regarding the Product(s) and/or previous versions of this document.

Melexis NV © - No part of this document may be reproduced without the prior written consent of Melexis. (2016)

ISO/TS 16949 and ISO14001 Certified

Данный компонент на территории Российской Федерации

Вы можете приобрести в компании MosChip.

Для оперативного оформления запроса Вам необходимо перейти по данной ссылке:

<http://moschip.ru/get-element>

Вы можете разместить у нас заказ для любого Вашего проекта, будь то серийное производство или разработка единичного прибора.

В нашем ассортименте представлены ведущие мировые производители активных и пассивных электронных компонентов.

Нашей специализацией является поставка электронной компонентной базы двойного назначения, продукции таких производителей как XILINX, Intel (ex.ALTERA), Vicor, Microchip, Texas Instruments, Analog Devices, Mini-Circuits, Amphenol, Glenair.

Сотрудничество с глобальными дистрибьюторами электронных компонентов, предоставляет возможность заказывать и получать с международных складов практически любой перечень компонентов в оптимальные для Вас сроки.

На всех этапах разработки и производства наши партнеры могут получить квалифицированную поддержку опытных инженеров.

Система менеджмента качества компании отвечает требованиям в соответствии с ГОСТ Р ИСО 9001, ГОСТ РВ 0015-002 и ЭС РД 009

Офис по работе с юридическими лицами:

105318, г.Москва, ул.Щербаковская д.3, офис 1107, 1118, ДЦ «Щербаковский»

Телефон: +7 495 668-12-70 (многоканальный)

Факс: +7 495 668-12-70 (доб.304)

E-mail: info@moschip.ru

Skype отдела продаж:

moschip.ru

moschip.ru_4

moschip.ru_6

moschip.ru_9