



Main

Range of product	Magelis SCU
Product or component type	Small touch HMI controller
Display size	5.7 inch
Display type	With backlit LED colour TFT LCD
Touch panel	Analogue
Device presentation	Complete product

Complementary

Display resolution	320 x 240 pixels QVGA
Backlight lifespan	50000 hours with 65000 colours
Brightness	16 levels via touch panel
View angle horiz x vert	60° left 60° right 40° top 60° bottom
Character font	ASCII Chinese (simplified Chinese) Japanese (ANK, Kanji) Korean Taiwanese (traditional Chinese)
Supply	External source
[Us] rated supply voltage	24 V at 20.4...28.8 V DC
Immunity to microbreaks	<= 10 ms
Inrush current	<= 30 A
Power consumption in W	24 W
Local signalling	No indicator
Number of pages	Limited by internal memory capacity
Software designation	SoMachine
Operating system	Magelis
Processor name	CPU RISC
Processor frequency	333 MHz
Memory description	128 MB flash memory, type: NAND 128 kB internal data storage memory, type: FRAM 128 MB application run memory, type: DRAM
Integrated connection type	1 RJ45 connector serial link with RS232/RS485 interface at <= 115.2 kbits/s 1 RJ45 connector Ethernet TCP/IP 1 USB 2.0 type mini B 1 USB 2.0 type A SUB-D 9 connector CANopen master bus
Realtime clock	Built-in
Downloadable protocols	Modbus Modbus TCP/IP CANopen
Fixing mode	By 1 nut - diameter: Ø 22 mm, mounting on: 1...6 mm thick panel
Enclosure material	PC/PBT and PAA
Shock resistance	147 m/s ² (duration=11 ms) conforming to IEC 60068-2-27 on DIN rail 294 m/s ² (duration=6 ms) conforming to IEC 60068-2-27 on panel mounting
Vibration resistance	+/- 3.5 mm (f=5...9 Hz) conforming to IEC 60068-2-6 1 gn (f=9...150 Hz) conforming to IEC 60068-2-6

The information provided in this documentation contains general descriptions and/or technical characteristics of the performance of the products contained herein. This documentation is not intended as a substitute for and is not to be used for determining suitability or reliability of these products for specific user applications. It is the duty of any such user or integrator to perform the appropriate and complete risk analysis, evaluation and testing of the products with respect to the relevant specific application or use thereof. Neither Schneider Electric Industries SAS nor any of its affiliates or subsidiaries shall be responsible or liable for misuse of the information contained herein.

Electromagnetic compatibility

Electrostatic discharge immunity test - test level: 8 kV, air discharge conforming to IEC 61000-4-2
 Electrostatic discharge immunity test - test level: 6 kV, contact discharge conforming to IEC 61000-4-2
 Susceptibility to electromagnetic fields - test level: 10 V/m, 80 MHz...3 GHz conforming to IEC 61000-4-3
 Electrical fast transient/burst immunity test - test level: 2 kV, power lines conforming to IEC 61000-4-4
 Electrical fast transient/burst immunity test - test level: 1 kV, between analogue I/O and operating voltage conforming to IEC 61000-4-4
 Electrical fast transient/burst immunity test - test level: 2 kV, relay wires conforming to IEC 61000-4-4
 Electrical fast transient/burst immunity test - test level: 1 kV, Ethernet line conforming to IEC 61000-4-4
 Electrical fast transient/burst immunity test - test level: 1 kV, COM line conforming to IEC 61000-4-4
 Electrical fast transient/burst immunity test - test level: 1 kV, CAN line conforming to IEC 61000-4-4
 Surge immunity test - test level: 2 kV, power supply (common mode) conforming to IEC 61000-4-5
 Surge immunity test - test level: 1 kV, power supply (differential mode) conforming to IEC 61000-4-5
 Surge immunity test - test level: 1 kV common mode, digital I/O conforming to IEC 61000-4-5
 Surge immunity test - test level: 0.5 kV differential mode, digital I/O conforming to IEC 61000-4-5
 Conducted RF disturbances - test level: 10 V, 0.15...80 MHz conforming to IEC 61000-4-6
 Conducted emission - test level: 150 kHz...30 MHz conforming to EN 55011
 Radiated emission - test level: 30 MHz...1 GHz conforming to EN 55011

Discrete input number	2 fast input (normal mode) conforming to IEC 61131-2 Type 1 6 digital input conforming to IEC 61131-2 Type 1
Discrete input voltage	24 V DC discrete input logic:sink or source (positive/negative)
Number of common point	1 fast input (HSC mode) 1 digital input
Discrete input current	7.83 mA fast input 5 mA digital
Input impedance	4.7 kOhm 2.81 kOhm
Sensor power supply	15...28.8 V DC, voltage (state 1): ≥ 15 V, current (state 1): ≥ 5 mA, voltage (state 0): ≤ 5 V, current (state 0): ≤ 1.5 mA 15...28.8 V DC, voltage (state 1): ≥ 15 V, current (state 1): ≥ 2.5 mA, voltage (state 0): ≤ 5 V, current (state 0): ≤ 1 mA
Configurable filtering time	0 ms no filter (none) 0.004...0.04 ms bounce filter (latch/event and cumulative filter by step $N \times 0.5$ ms ($64 \geq N \geq 2$)) 3...12 ms integrator (none/run/stop)
Input frequency	100 kHz for fast input (encoder mode) - control type A/B 100 kHz for fast input - control type single phase 100 kHz for fast input - control type pulse/direction
Cable distance between devices	Shielded cable: 10 m for fast input Shielded cable: 100 m for digital input Unshielded cable: 50 m for digital input
Connection pitch	0.14 in (3.5 mm)
Overvoltage protection	With
Isolation between channels and internal logic	500 V DC
Isolation between channels	None
Discrete output number	2 fast output (normal mode), output logic: source 6 digital output, output logic: source
Discrete output voltage	24 V DC (voltage limit: 19.2...28.8 V) with transistor discrete output(s) 24 V DC (voltage limit: 5...30 V) with relay discrete output(s) 220 V AC (voltage limit: 100...250 V) with relay discrete output(s)
Input/output number	2 fast input, terminal(s): F10...F11 2 fast output, terminal(s): FQ0...FQ1 6 digital input, terminal(s): DI0...DI5 6 digital output, terminal(s): DQ0...DQ5
Discrete output current	300 mA, response time 2 ms fast output (normal mode) 50 mA, response time 2 ms fast output (PWM or PTO mode) 2 A (current per output common:4 A), response time 5 ms with opening contact for digital output 2 A (current per output common:4 A), response time 2 ms with closing contact for digital output

Insulation resistance	> 10 MOhm between the I/O and internal logic > 10 MOhm between power supply and earth
Output frequency	<= 100 kHz for fast output (PTO mode) <= 1 kHz for fast output (PWM mode)
Absolute accuracy error	+/- 0.1 % of full scale of cyclic ratio 1...99% fast output (PWM or PTO mode) 1 % of full scale of cyclic ratio 1...99% fast output (PWM or PTO mode) +/- 5 % of full scale of cyclic ratio 10...90% fast output (PWM or PTO mode) +/- 10 % of full scale of cyclic ratio 20...80% fast output (PWM or PTO mode) +/- 15 % of full scale of cyclic ratio 30...70% fast output (PWM or PTO mode)
Analogue input number	2 analog input 2 RTDs
Analogue input range	0...20 mA/4...20 mA - resolution: 12 bits, input impedance: 250 Ohm (tolerance: +/- 1 %) -10...+10 V or 0...10 V - resolution: 12 bits + sign, input impedance: >= 1 MOhm
Analogue input type	RTD at - 200...600 °C - resolution: 16 bits temperature probe: Pt 100/Pt 1000 RTD at - 50...200 °C - resolution: 16 bits temperature probe: Ni 100/Ni 1000 RTD at - 200...760 °C - resolution: 16 bits (thermocouple J) RTD at - 240...1370 °C - resolution: 16 bits (thermocouple K) RTD at 0...1600 °C - resolution: 16 bits (thermocouple R) RTD at 200...1800 °C - resolution: 16 bits (thermocouple B) RTD at 0...1600 °C - resolution: 16 bits (thermocouple S) RTD at - 200...400 °C - resolution: 16 bits (thermocouple T) RTD at - 200...900 °C - resolution: 16 bits (thermocouple E) RTD at - 200...1300 °C - resolution: 16 bits (thermocouple N)
Analogue output number	2 resistive load 12 bits + sign
Analogue output range	0...20 mA/4...20 mA (> 300 Ohm) for open-circuit -10...10 V/0...10 V (> 2 kOhm) short-circuit
Height	5.09 in (129.4 mm)
Width	6.42 in (163 mm)
Depth	3 in (76.22 mm)
Product weight	1.77 lb(US) (0.803 kg)

Environment

standards	EN 61131-2 FCC Class A IEC 61000-6-2 RoHS compliant UL 508 ANSI/ISA 12-12-01 WEEE directive 2002/96/EC CSA C22.2 No 213 Class I Division 2 RoHS China SJ/T 11363-2006
product certifications	C-Tick CULus 508 GOST CUL 1604 Class 1 Division 2 KCC CULus CSA 22-2 No 142
marking	CE
ambient air temperature for operation	32...122 °F (0...50 °C)
ambient air temperature for storage	-4...140 °F (-20...60 °C)
relative humidity	5...85 % without condensation
operating altitude	<= 6561.68 ft (2000 m)
storage altitude	0...10000 m
maximum pressure	800...1114 hPa
IP degree of protection	IP65 front panel conforming to IEC 60529 IP20 rear panel conforming to IEC 60529
NEMA degree of protection	NEMA 4X front panel
pollution degree	2 conforming to IEC 60664
environmental characteristic	Corrosive gas free

Offer Sustainability

Green Premium product	Green Premium product
Compliant - since 0844 - Schneider Electric declaration of conformity	Compliant - since 0844 - Schneider Electric declaration of conformity

Reference not containing SVHC above the threshold	Reference not containing SVHC above the threshold
Available	Available
Available	Available
WARNING: This product can expose you to chemicals including:	WARNING: This product can expose you to chemicals including:
Lead and lead compounds, which is known to the State of California to cause cancer and birth defects or other reproductive harm.	Lead and lead compounds, which is known to the State of California to cause cancer and birth defects or other reproductive harm.
For more information go to www.p65warnings.ca.gov	For more information go to www.p65warnings.ca.gov

Dimensions

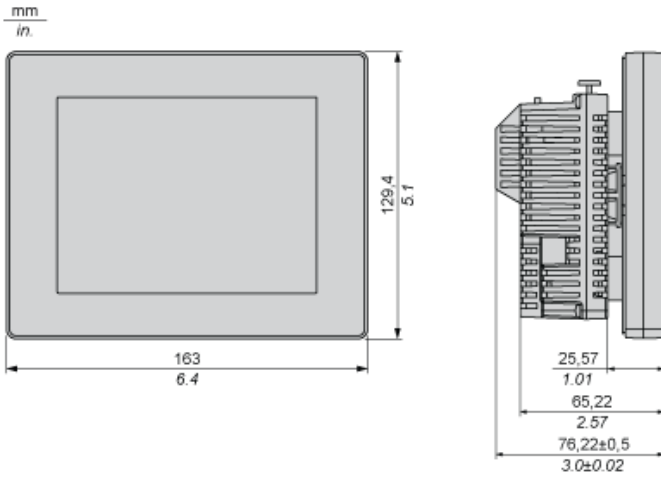

Recommended Mounting position

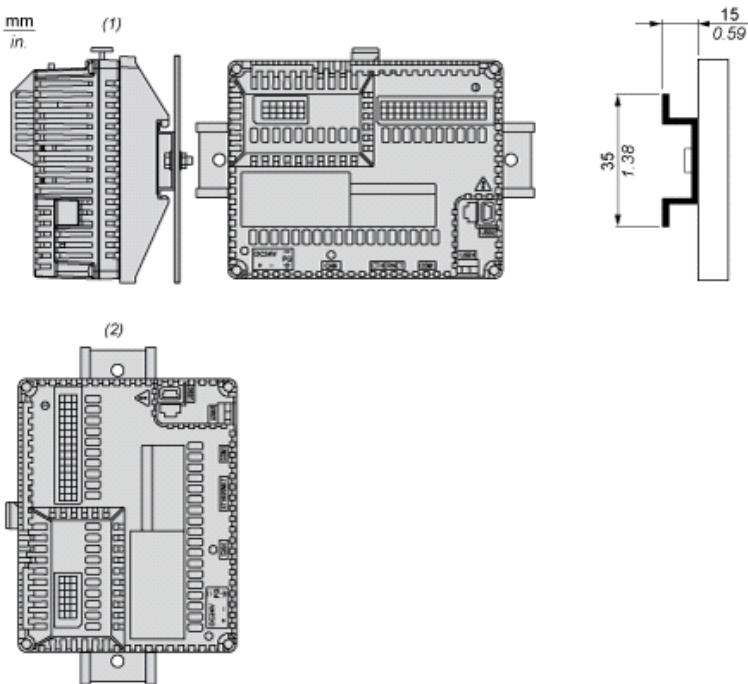

- (1) Horizontal mounting
- (2) Vertical mounting

No Recommended Mounting Position

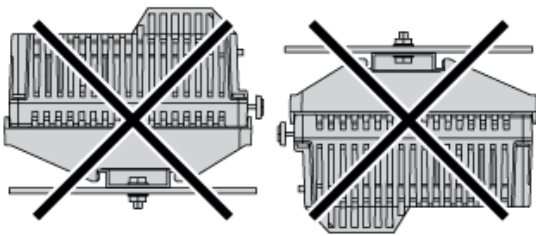

Clearance

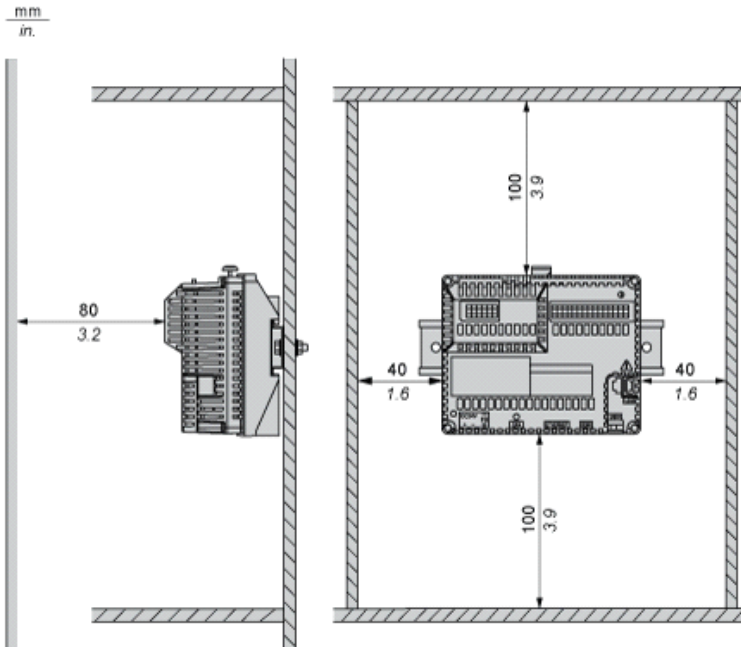

Keep adequate spacing for proper ventilation to maintain an ambient temperature between 0...50 °C (32...122 °F) for horizontal installation and 0...40 °C (32...104 °F) for vertical installation.

Wiring Diagram

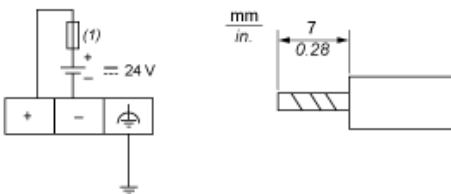

(1) Slow-blow 2A type T fuse

Wiring Diagram of the Analog Inputs and Analog Outputs

Voltage for Analog Inputs

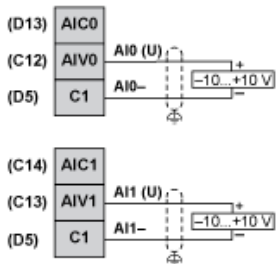

Current for Analog Inputs

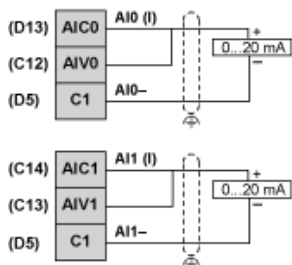

Voltage and Current for Analog Outputs

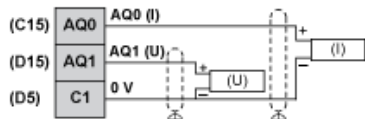

3 Wiring for Analog Inputs PT100

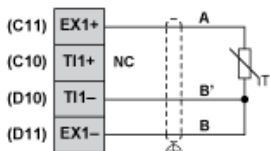
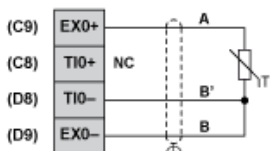

2 Wiring for Analog Inputs PT100

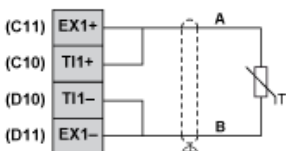
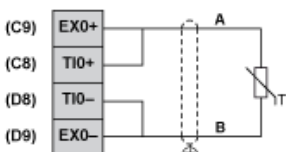

Thermocouple

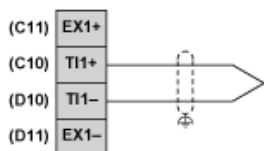
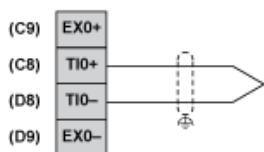

Wiring Diagram of Digital Inputs

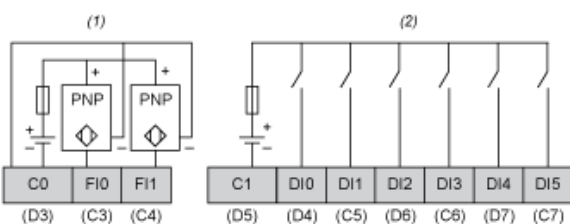

(1) HSC inputs with pin assignment of terminal blocks C,D.

(2) Digital inputs with pin assignment of terminal blocks C,D.

Wiring Diagram of Digital Outputs

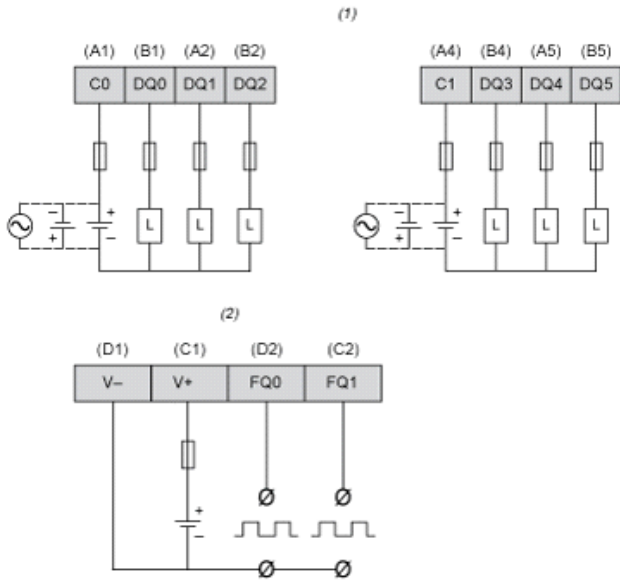

(1) Digital outputs with pin assignment of terminal blocks A,B.

(2) PWM outputs with pin assignment of terminal blocks C,D.

Данный компонент на территории Российской Федерации

Вы можете приобрести в компании MosChip.

Для оперативного оформления запроса Вам необходимо перейти по данной ссылке:

<http://moschip.ru/get-element>

Вы можете разместить у нас заказ для любого Вашего проекта, будь то серийное производство или разработка единичного прибора.

В нашем ассортименте представлены ведущие мировые производители активных и пассивных электронных компонентов.

Нашей специализацией является поставка электронной компонентной базы двойного назначения, продукции таких производителей как XILINX, Intel (ex.ALTERA), Vicor, Microchip, Texas Instruments, Analog Devices, Mini-Circuits, Amphenol, Glenair.

Сотрудничество с глобальными дистрибьюторами электронных компонентов, предоставляет возможность заказывать и получать с международных складов практически любой перечень компонентов в оптимальные для Вас сроки.

На всех этапах разработки и производства наши партнеры могут получить квалифицированную поддержку опытных инженеров.

Система менеджмента качества компании отвечает требованиям в соответствии с ГОСТ Р ИСО 9001, ГОСТ РВ 0015-002 и ЭС РД 009

Офис по работе с юридическими лицами:

105318, г.Москва, ул.Щербаковская д.3, офис 1107, 1118, ДЦ «Щербаковский»

Телефон: +7 495 668-12-70 (многоканальный)

Факс: +7 495 668-12-70 (доб.304)

E-mail: info@moschip.ru

Skype отдела продаж:

moschip.ru

moschip.ru_4

moschip.ru_6

moschip.ru_9