

PART NUMBER
(INCLUDE :2 CONNECTORS
+ 1 MEZZANINE PCB)

DIM "A"
STACK HEIGHT
(±0.50)

A	10127597-001LF	32
	10127597-002LF	33
	10127597-003LF	34
	10127597-004LF	35
	10127597-005LF	36
B	10127597-006LF	37
	10127597-007LF	38
	10127597-008LF	39
	10127597-009LF	40
	10127597-010LF	41
	10127597-011LF	42

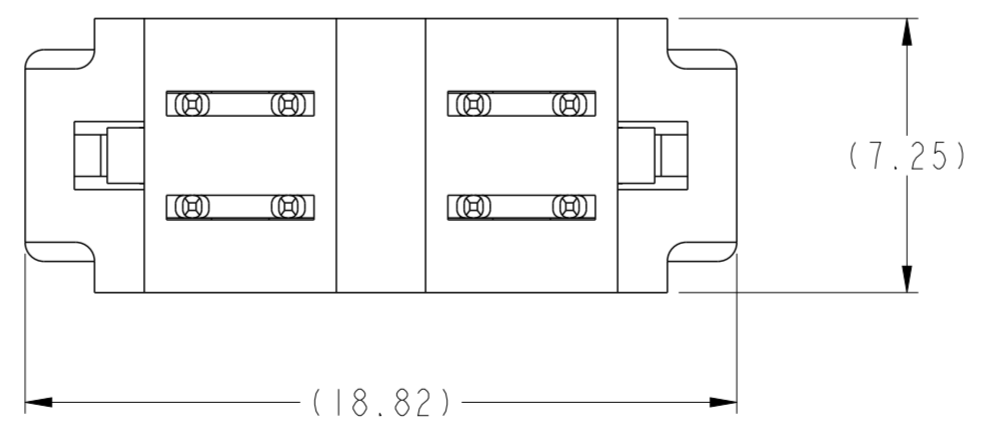
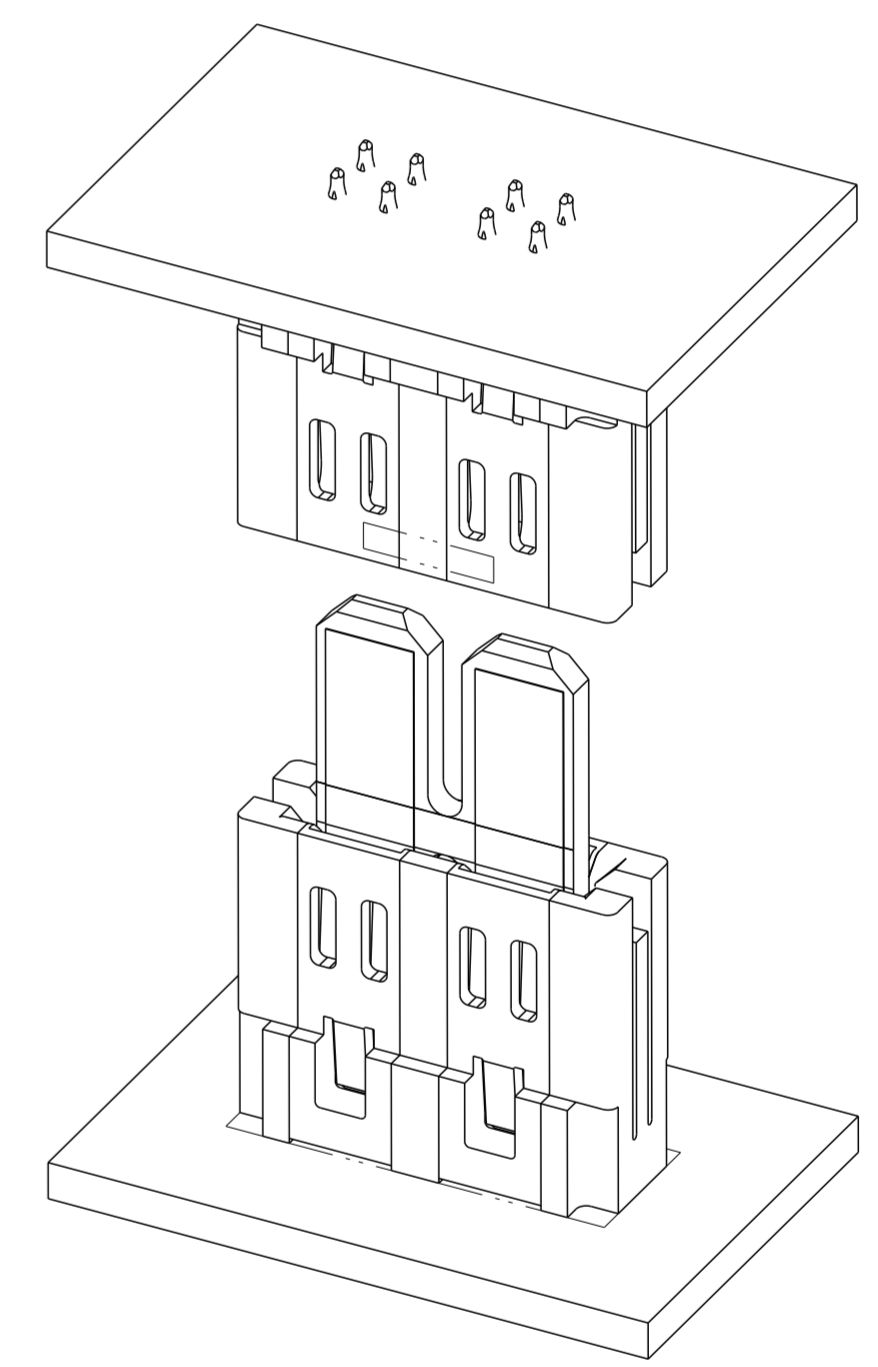
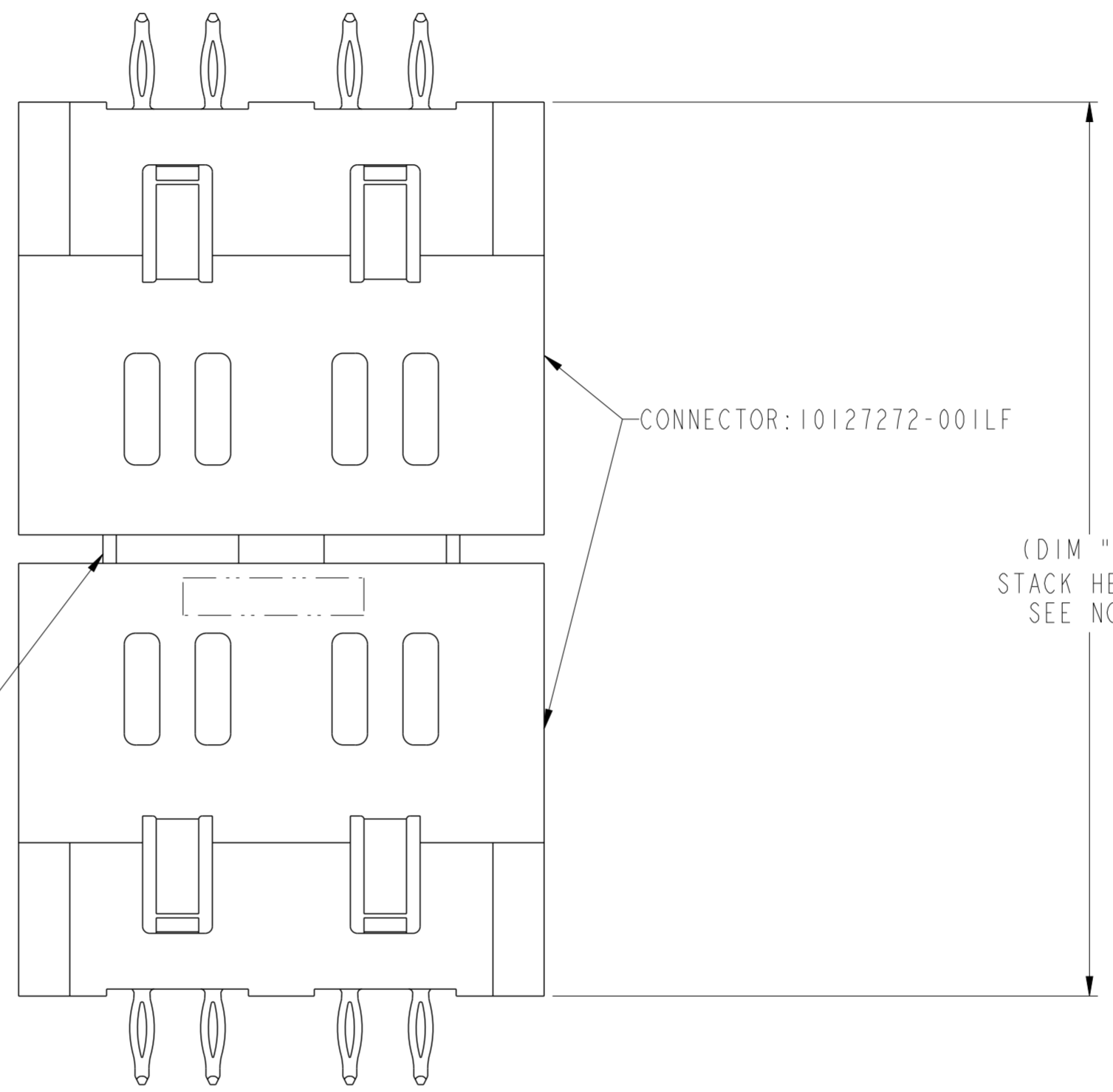

NOTE:

INTENDED USE-- TWO CONNECTORS (P/N 10127272) MEZZANINE STACKED USING PCB TO CONTROL STACK HEIGHT.
FINAL MEZZANINE STACK HEIGHT RANGES FROM 32~42 mm IN 1 mm INCREMENTS.

Amphenol FCI

© 2016 AFCl

spec ref	-	dr	Jackie Huang	2015/04/15	projection	MM	size	A2	scale	2:1	
tolerance std	ISO 406 ISO 1101	eng	Sunny2 Liu	2016/04/12			ecn no	ELX-DG-22934-1			
TOLERANCES UNLESS OTHERWISE SPECIFIED		chr	Terris Liu	2016/05/20			rel level	Released			
surface	linear	0.X	±0.5	0.XX	±0.25	Amphenol FCI	title	ASSY VERT RECP (8P) HIGH POWER CARD EDGE			
ASME Y14.5	angular	0.XXX	±0.10	0°	±2°	cat. no.	-	Product - Customer Drw	sheet 1 of 4	rev	B

PDS: Rev :B

STATUS:Released

Printed: May 24, 2016

PART NUMBER
(CONNECTOR)

10127272-001LF

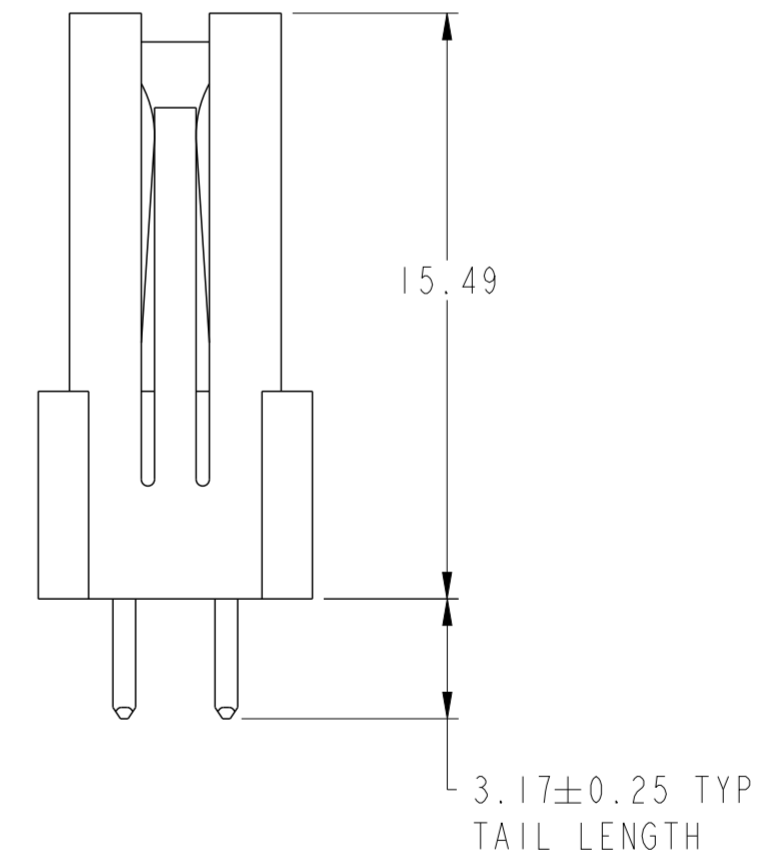
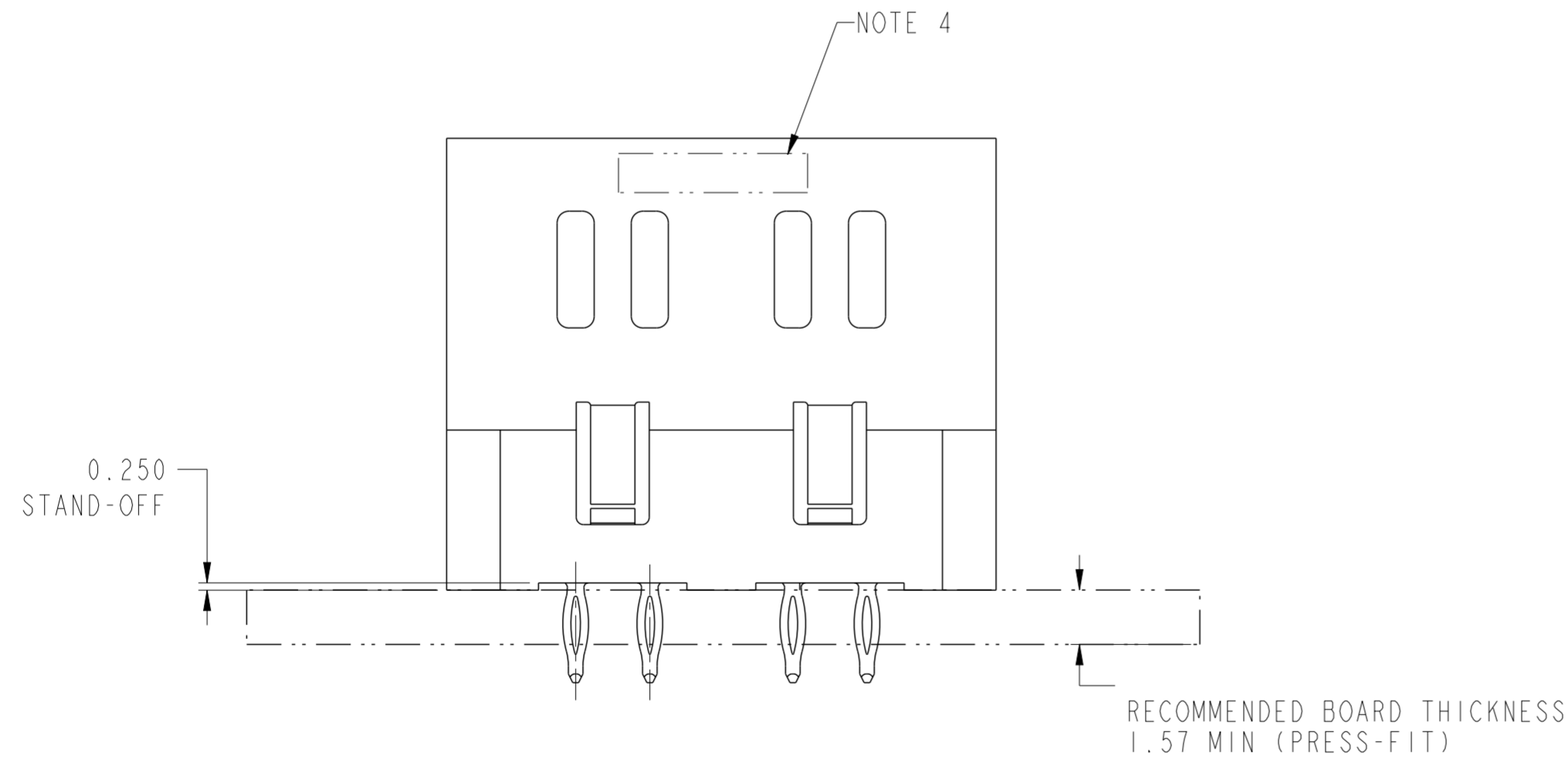
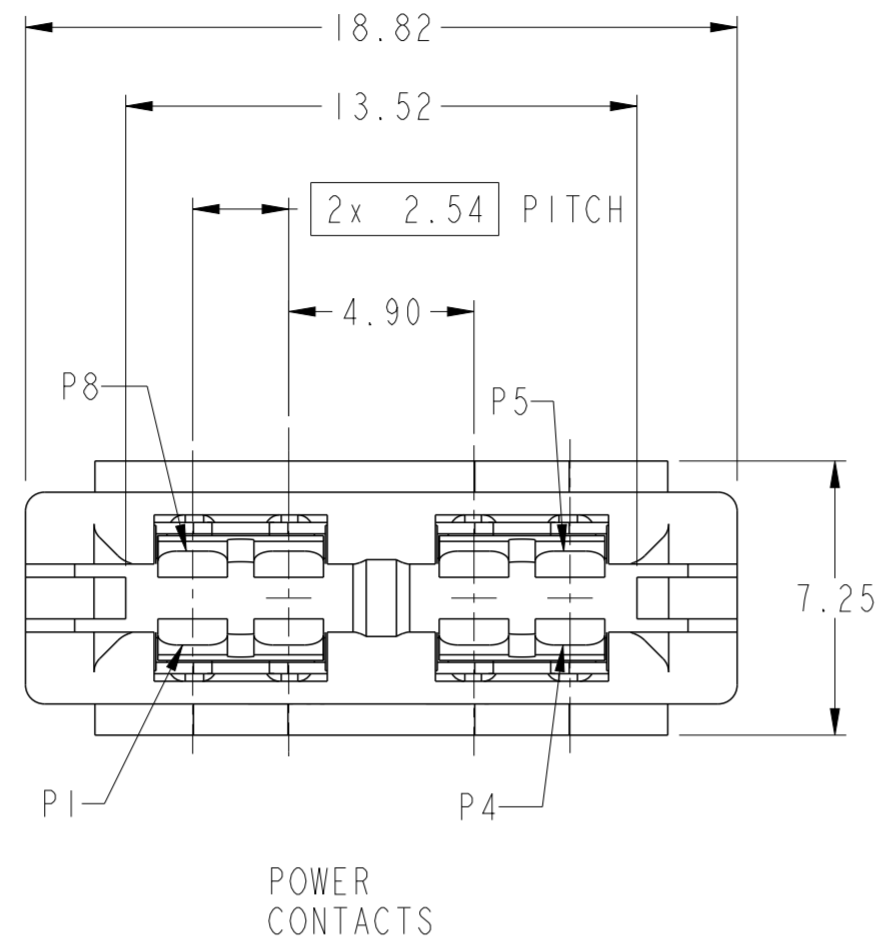

spec ref	-	dr	Jackie Huang	2015/04/15	projection	MM	size	A2	scale	5:1	
tolerance std	ISO 406 ISO 1101	eng	Sunny2 Liu	2016/04/12			ecn no	ELX-DG-22934-1			
TOLERANCES UNLESS OTHERWISE SPECIFIED		chr	Terris Liu	2016/05/20			rel level	Released			
surface	ASME Y14.5	appr	Pai-Ming Zheng	2016/05/24	product family	CARD EDGE	divg no	10127597		rev	B
linear	0.X ±0.5 0.XX ±0.25 0.XXX ±0.10	Amphenol FCI		title	ASSY VERT RECP (8P) HIGH POWER CARD EDGE		cat. no.	-		Product - Customer Drw	sheet 2 of 4
angular	0° ±2°	PDS: Rev :B		STATUS:Released		Printed: May 24, 2016					

TABLE I (HPCE / PRESS-FIT TAILS)
PLATED THROUGH-HOLE REQUIREMENTS

CONTACT TYPE	TOP LAYER DESCRIPTION	DRILLED HOLE DIAMETER	COPPER THICKNESS	TIN-LEAD THICKNESS	TIN THICKNESS	FINISHED HOLE DIAMETER
		TIN-LEAD	0.81-0.86 (0.85 DRILL)	0.025 - 0.050	0.005 - 0.015	--
POWER & SIGNAL	IMMERSION TIN	0.81-0.86 (0.85 DRILL)	0.025 - 0.050	--	0.9 - 1.5um	0.70 - 0.80
	COPPER (SEE NOTE 7)	0.81-0.86 (0.85 DRILL)	0.025 - 0.050	--	--	0.70 - 0.80

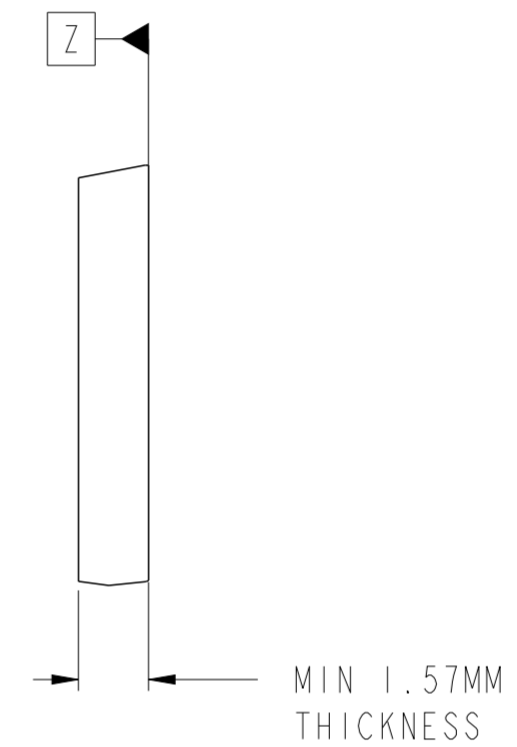
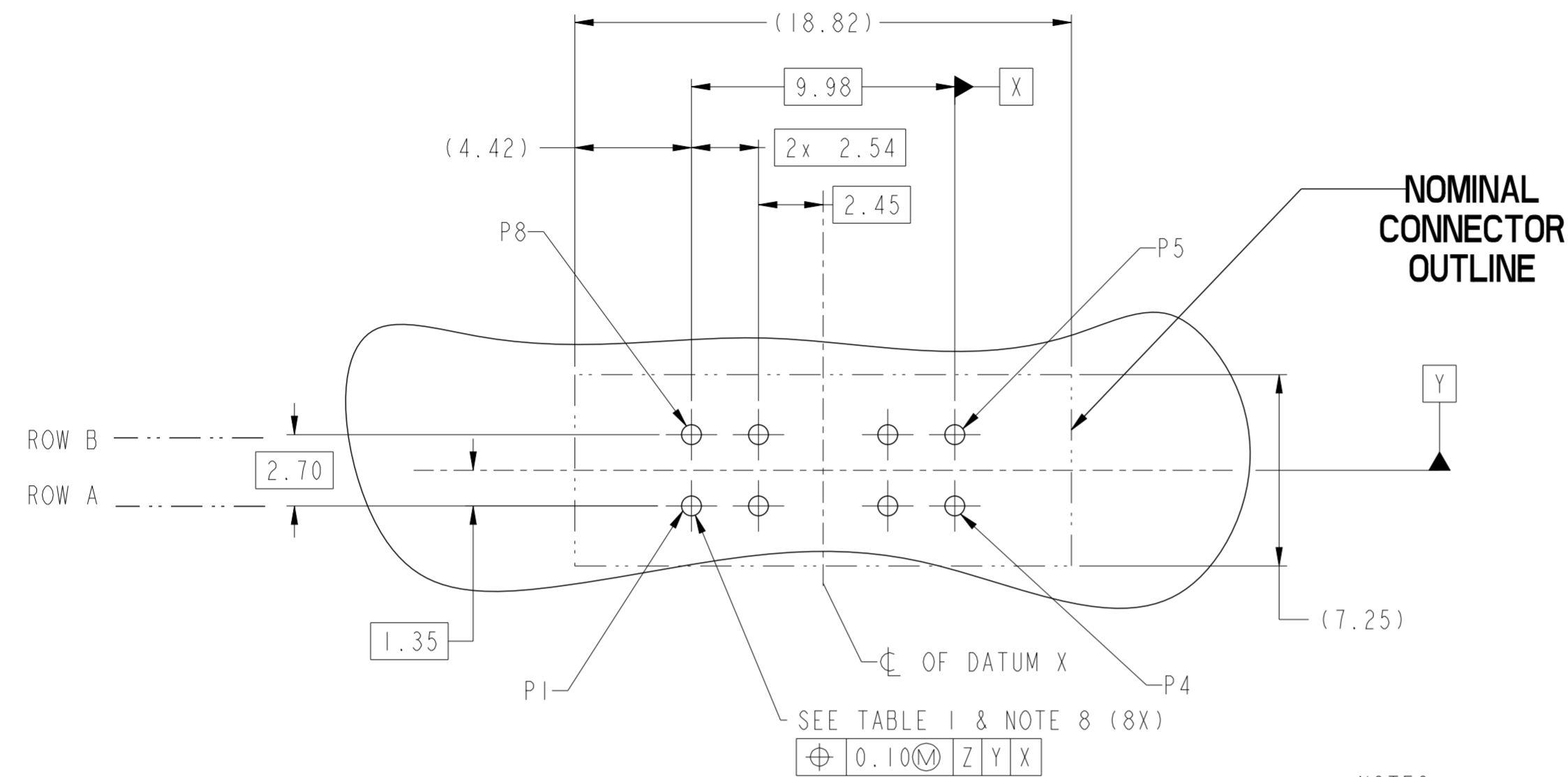

RECOMMENDED PCB LAYOUT
VIEWED FROM CONNECTOR SIDE

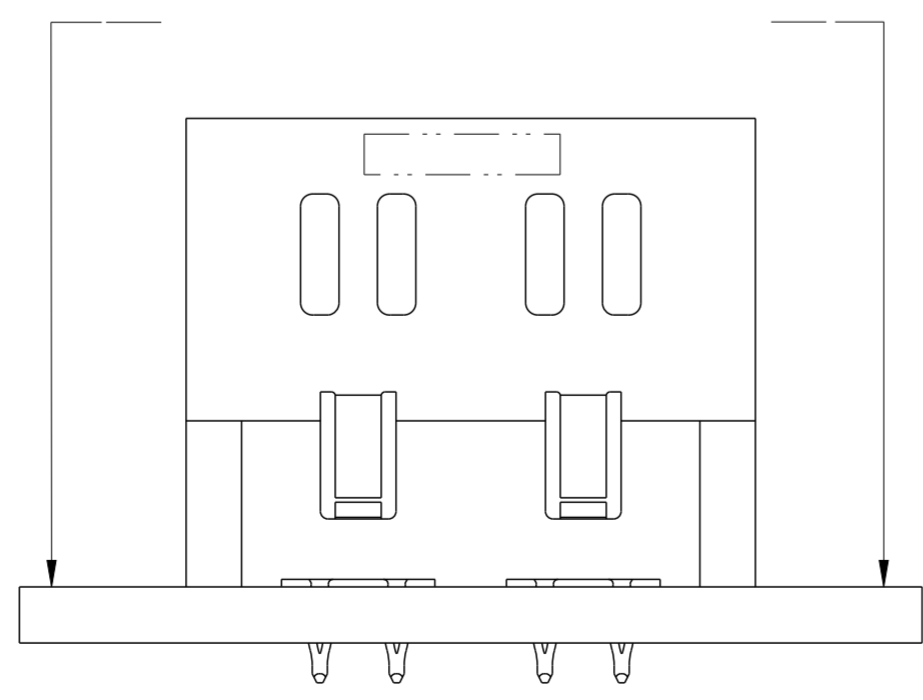

NOTES:

- CONNECTOR MATERIALS:
HOUSING: HIGH TEMPERATURE THERMAL PLASTIC, BLACK
UL 94V-0 COMPLIANT
CONTACTS: HIGH PERFORMANCE COPPER ALLOY.
- CONTACT FINISH REF. GS-12-1261 SECTION 5.2.
- PRODUCT SPECIFICATION: GS-12-1261.
- PRODUCT MARKING ON HOUSING IN AREA SHOWN MEETS AFCI SPECIFICATION: GS-24-007.
- PACKAGING MEETS FCI SPECIFICATION GS-14-2456.
- HOUSING COMPONENT WILL WITHSTAND EXPOSURE TO 260°C PEAK TEMPERATURE FOR 60 SECONDS IN A CONVECTION, INFRA-RED, OR VAPOR PHASE REFLOW OVEN.
- COPPER PLATING THICKNESS IN CENTER OF VIA-HOLE CAN BE NO MORE THAN 0.003 LESS THAN OTHER AREAS.
- ALL HOLE SIZES ARE FINISHED HOLE SIZES.
- A SYMBOL $\triangle B$ WILL BE NEXT TO ANY DIMENSION, VIEW, OR NOTE WHICH HAS BEEN MODIFIED WITH THE CURRENT DRAWING REVISION.

spec ref	-	dr	Jackie Huang	2015/04/15	projection	MM	size	A2	scale	2:1
tolerance std	ISO 406 ISO 1101	eng	Sunny2 Liu	2016/04/12			ecn no	ELX-DG-22934-1	rel level	Released
TOLERANCES UNLESS OTHERWISE SPECIFIED		chr	Terris Liu	2016/05/20						
surface	ASME Y14.5	appr	Pai-Ming Zheng	2016/05/24	Amphenol FCI		ASSY VERT RECP (8P) HIGH POWER CARD EDGE	dwg no 10127597	rev B	
linear	0.X ±0.5 0.XX ±0.25 0.XXX ±0.10	cat. no.	-		Product - Customer Drw		sheet 3 of 4			
angular	0° ±2°									

Amphenol FCI

© 2016 AFCI

PART NUMBER (MEZZANINE PCB)	DIM "L" (±0.25)	STACK HEIGHT (±0.50)
10127274-001LF	21.02	32
10127274-002LF	22.02	33
10127274-003LF	23.02	34
10127274-004LF	24.02	35
10127274-005LF	25.02	36
10127274-006LF	26.02	37
10127274-007LF	27.02	38
10127274-008LF	28.02	39
10127274-009LF	29.02	40
10127274-010LF	30.02	41
10127274-011LF	31.02	42

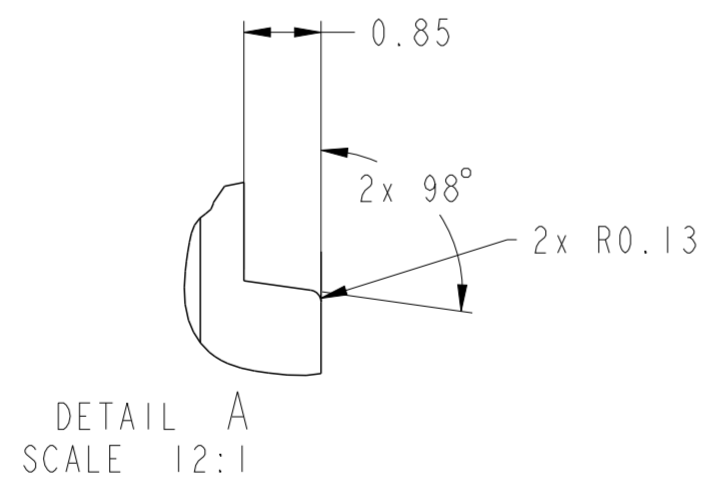
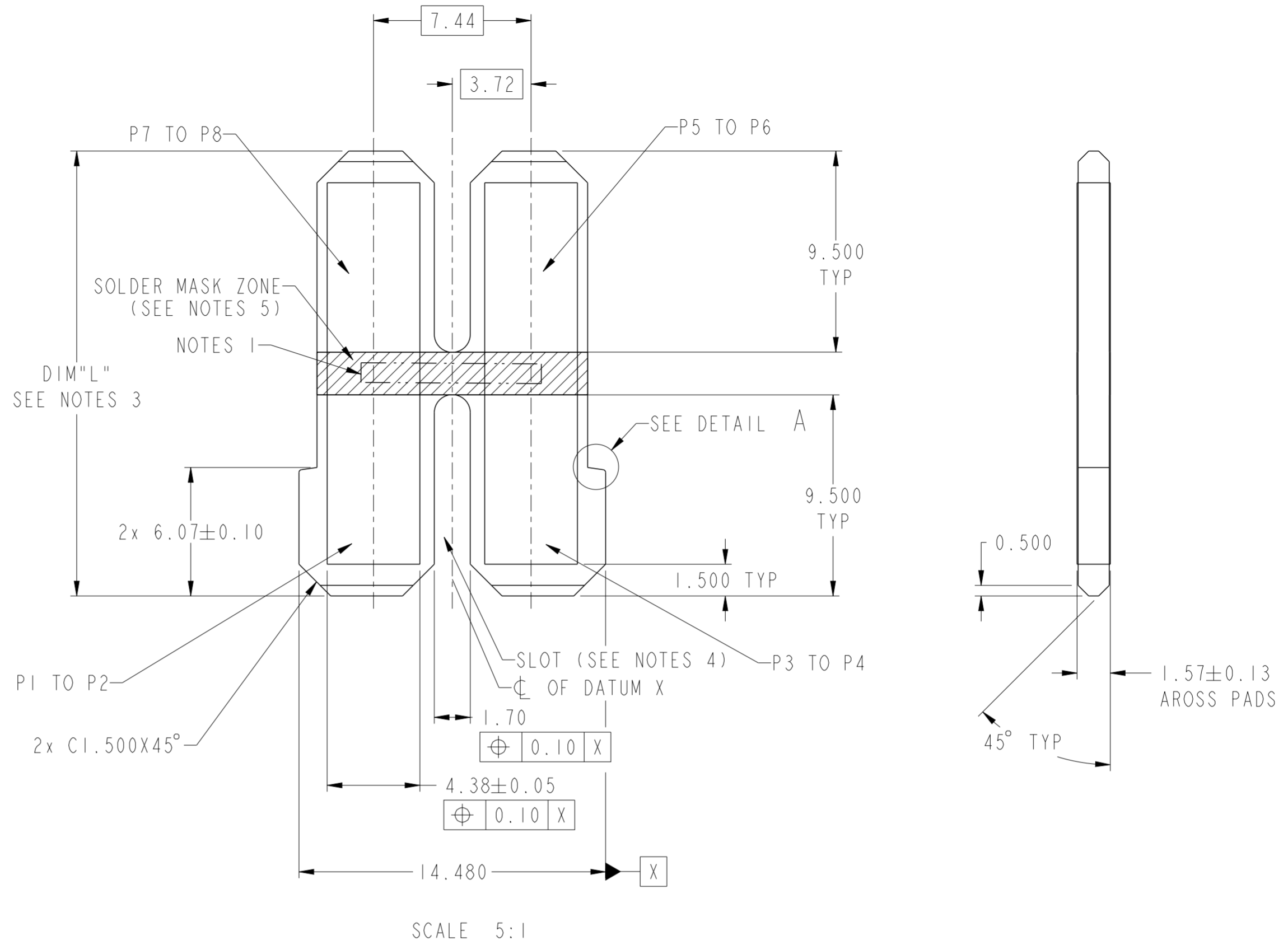

NOTES:

1. PRODUCT MARKING ON HOUSING IN AREA SHOWN MEETS AFCl SPECIFICATION: GS-24-007.
2. PACKAGING MEETS FCI SPECIFICATION GS-14-2456.
3. INTENDED USE: TWO CONNECTORS (P/N 10127272) MEZZANINE STACKED USING PCB TO CONTROL STACK HEIGHT.
DIM "L" + 10.98mm = FINAL MEZZANINE STACK HEIGHT.
DIM "L" RANGES FROM 21.02-31.02 mm IN 1 mm INCREMENTS.
4. WHEN DIM "L" DECREASED, THE STRENGTH OF PCB MAY BE THINNER CAUSED BY THESE SLOTS. SEPARATE SIGNAL AND POWER BOARDS MAY BE USED.
5. SOLDER MASK TO BE PRESENT ON BOTH SIDES IN HATCHED AREA;
6. A SYMBOL $\triangle B$ WILL BE NEXT TO ANY DIMENSION, VIEW, OR NOTE WHICH HAS BEEN MODIFIED WITH THE CURRENT DRAWING REVISION.

spec ref	-	dr	Jackie Huang	2015/04/15	projection	MM	size	A2	scale	3:1			
tolerance std	ISO 406 ISO 1101	eng	Sunny2 Liu	2016/04/12			ecn no	ELX-DG-22934-1	rel level	Released			
TOLERANCES UNLESS OTHERWISE SPECIFIED		chr	Terris Liu	2016/05/20							product family	-	
surface	ASME Y14.5	linear	0.X	±0.5	Amphenol FCI		title	ASSY VERT RECP (8P) HIGH POWER CARD EDGE		dwg no	10127597	rev	B
		angular	0°	±2°	cat. no.	-	Product - Customer Drw	sheet 4 of 4					

Данный компонент на территории Российской Федерации

Вы можете приобрести в компании MosChip.

Для оперативного оформления запроса Вам необходимо перейти по данной ссылке:

<http://moschip.ru/get-element>

Вы можете разместить у нас заказ для любого Вашего проекта, будь то серийное производство или разработка единичного прибора.

В нашем ассортименте представлены ведущие мировые производители активных и пассивных электронных компонентов.

Нашей специализацией является поставка электронной компонентной базы двойного назначения, продукции таких производителей как XILINX, Intel (ex.ALTERA), Vicor, Microchip, Texas Instruments, Analog Devices, Mini-Circuits, Amphenol, Glenair.

Сотрудничество с глобальными дистрибьюторами электронных компонентов, предоставляет возможность заказывать и получать с международных складов практически любой перечень компонентов в оптимальные для Вас сроки.

На всех этапах разработки и производства наши партнеры могут получить квалифицированную поддержку опытных инженеров.

Система менеджмента качества компании отвечает требованиям в соответствии с ГОСТ Р ИСО 9001, ГОСТ РВ 0015-002 и ЭС РД 009

Офис по работе с юридическими лицами:

105318, г.Москва, ул.Щербаковская д.3, офис 1107, 1118, ДЦ «Щербаковский»

Телефон: +7 495 668-12-70 (многоканальный)

Факс: +7 495 668-12-70 (доб.304)

E-mail: info@moschip.ru

Skype отдела продаж:

moschip.ru

moschip.ru_4

moschip.ru_6

moschip.ru_9