

Jul.1.2019 Copyright 2019 HIROSE ELECTRIC CO., LTD. All Rights Reserved.  
In case of consideration for using Automotive equipment / device which demand high reliability, kindly contact our sales window correspondents.

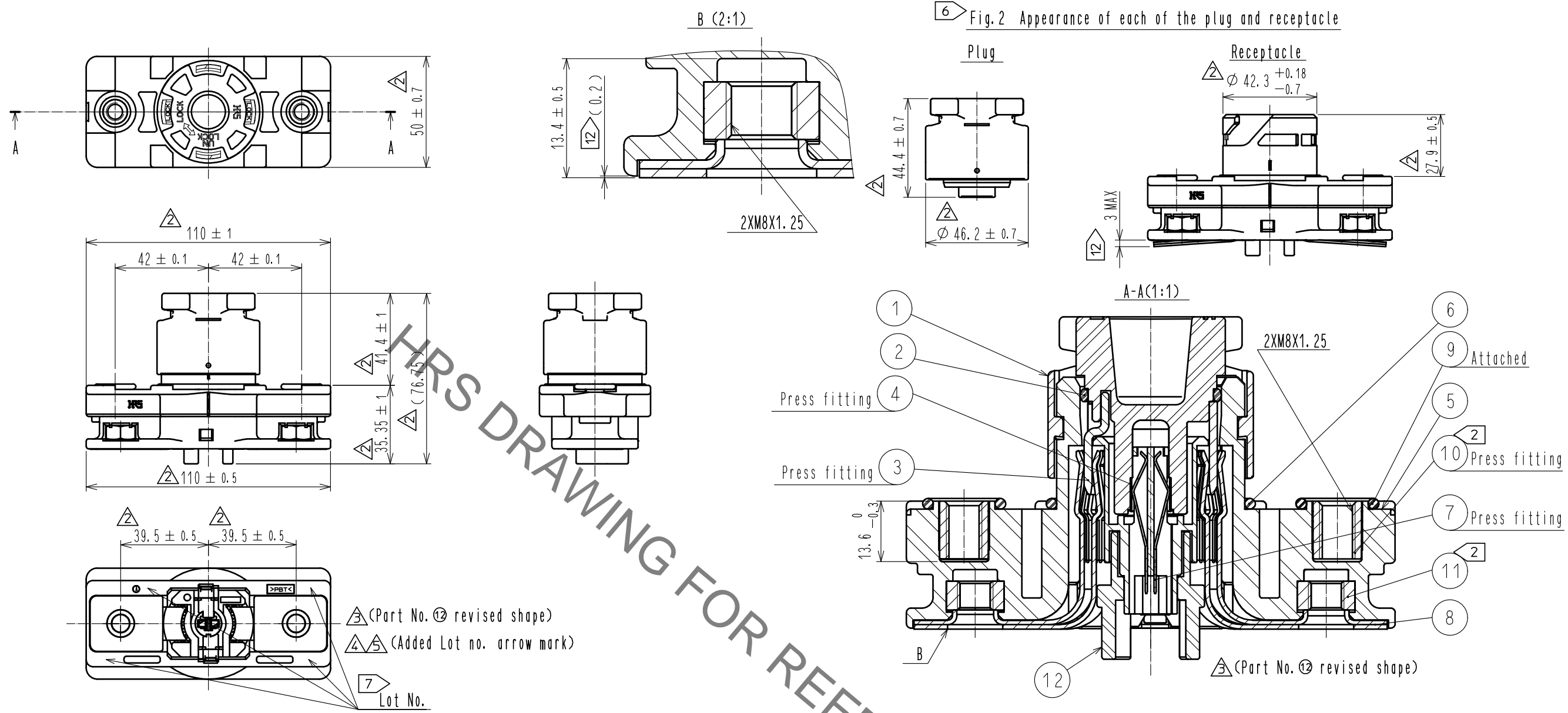

6 Fig.2 Appearance of each of the plug and receptacle

Notes

- Make sure that the O-ring is NOT twisting and properly assembled during this mounting process.
- Use ring terminal M8 for the power contact. The recommended tightening torque of Ref. No. ⑩ and ⑪ is 6.0 to 6.5 N·m. Recommended bolt size are as follows.
  - Ref. No. ⑩ : Screw size M8, Pitch 1.25 Length 10 to 12 mm. (For panel thickness, Refer to the next page Fig.1)
  - Ref. No. ⑪ : Screw size M8, Pitch 1.25 Length 12 to 15 mm. (Assume ring terminal thickness t = 2.5 to 3. When using ring terminal with different thickness, choose appropriate bolt size per the thickness.)
- Mating connector at signal contact side is as follows.

Connector	GT8E-2S-2C	CL758-0030-6-00	
Crimp contact	GT8E-2022SCF	CL758-0033-4-00	For AWG#20~22 Reel contact
	GT8B-2428SCF	CL758-0055-7-00	For AWG#24~28 Reel contact
	GT8E-2022SC	CL758-0101-2-00	For AWG#20~22 Bulk contact

- Fig.1 shows the recommended panel cut out dimensions. Roughness on the panel surface indicated by for water sealing must be  $\sqrt{Rz} 3.2$
- This product is delivered with the plug and receptacle unmated as shown in Fig. 4.
- Appearance of each of the plug and receptacle are shown in Fig.2
- Lot No. is marked in one the indicated part shown.

**WARNING** 8 Make sure the locking system firmly completed before using the this product. Fig.3 indicates rotated position of the plug and the receptacle with locking completed. Also, 'LOCK' marking on the receptacle can be seen from the plug hole.

**WARNING** 9 Never engage/disengage the plug while the power contacts (Ref. No. ③ and Ref. No. ⑥) are energized. Signal contacts are sequentially connected after the power line in the plug engagement, and disconnected before the power line in the disengagement. Therefore, use the product with the circuit to avoid hot-plugging provided. Mating sequence of power line and signal line are shown in Fig. 1 along with the appearance and circuit of each state.

10 Rotated position of the plug and the receptacle are is shown as an exapmle.

11 For product handling, refer to the Operation guide ETAD-C0320.

**WARNING** 12 Female contact Ref. No. ⑧ is loose before the bolt is attached to Ref. No. ⑩, and the female contact is movable as shown in Fig. 2. but stabilized to the receptacle after the screw fix. Therefore the looseness is eliminated for the use and does not affect its performance. (0.2) shown in Fig. ⑧ is the state when the bolt is tightened.

**WARNING** 13 Engage the plug to the receptacle after all the assembly including cable wiring are completed for safety.

NO.	MATERIAL	FINISH . REMARKS	NO.	MATERIAL	FINISH . REMARKS
6	Hydrogenation acrylonitrile butadiene rubber	(Black)	12	Polybutylene terephthalate	(Black) UL94V-0
5	Polybutylene terephthalate	(Orange) UL94V-0	11	Brass	Nickel plating
4	Copper alloy	Tin plating 1μm MIN	10	Brass	Nickel plating
3	Copper	Silver plating 3μm MIN	9	Hydrogenation acrylonitrile butadiene rubber	(Black)
2	Hydrogenation acrylonitrile butadiene rubber	(Black)	8	Copper alloy	Silver plating 3μm MIN
1	Polybutylene terephthalate	(Orange) UL94V-0	7	Copper alloy	Tin plating 1μm MIN

UNITS	SCALE	COUNT	DESCRIPTION OF REVISIONS	DESIGNED	CHECKED	DATE
mm	1 : 2	1	DIS-C-00001702	TY. SUZUKI	HY. KOBAYASHI	17. 11. 30
APPROVED : SU. OBARA 14. 07. 04			DRAWING NO. EDC3-118302-00			
CHECKED : HY. KOBAYASHI 14. 07. 04			PART NO. EM30MSD			
DESIGNED : TY. SUZUKI 14. 07. 02			CODE NO. CL138-0200-0-00			
DRAWN : TY. SUZUKI 14. 07. 02			1/2			

Jul.1.2019 Copyright 2019 HIROSE ELECTRIC CO., LTD. All Rights Reserved.  
 In case of consideration for using Automotive equipment / device which demand high reliability, kindly contact our sales window correspondents.

4 Fig.1 The recommended panel dimention (t = 2 to 4.5)

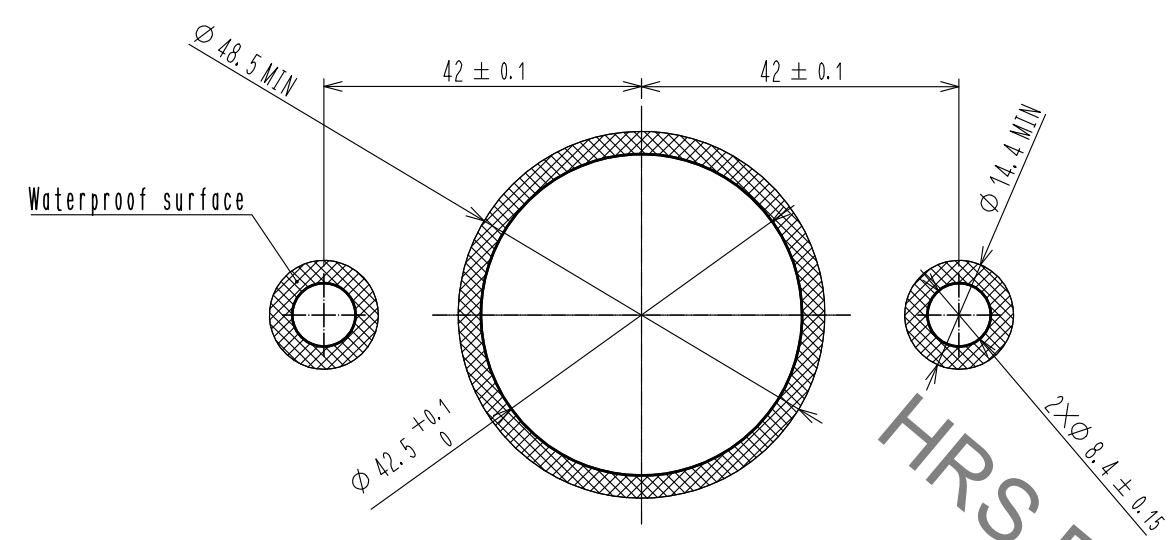

8 Fig.3 State of locked

Top face of HRS logo becomes parallele to the shortsides of the receptacle.  
 \*LOCK\* indication is visible.

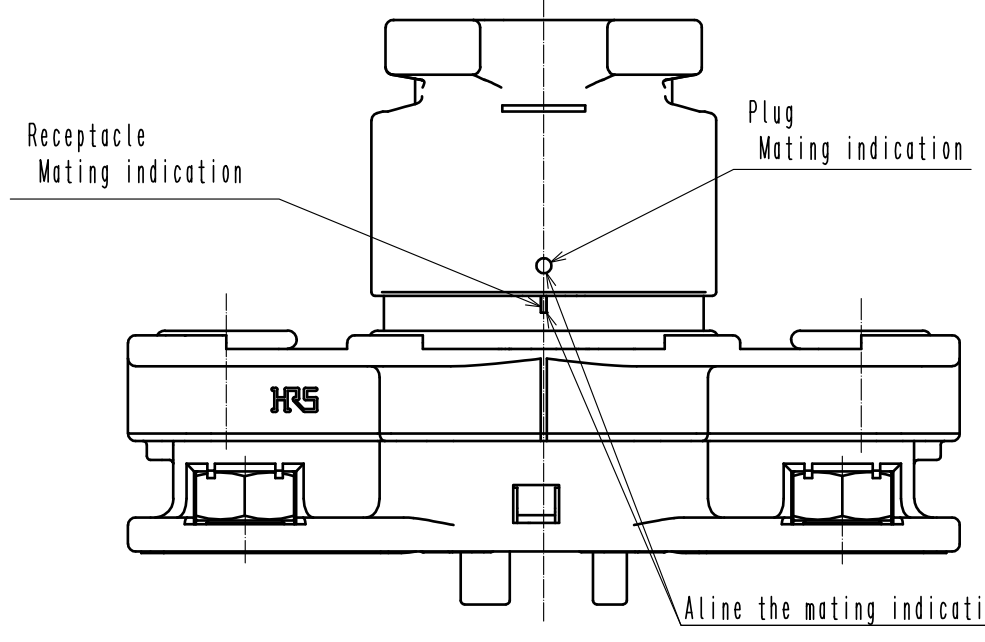
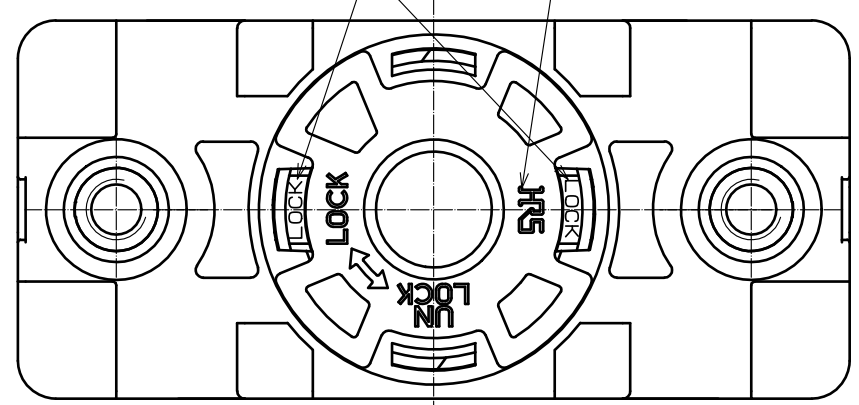

5 Fig.4 View of packing style

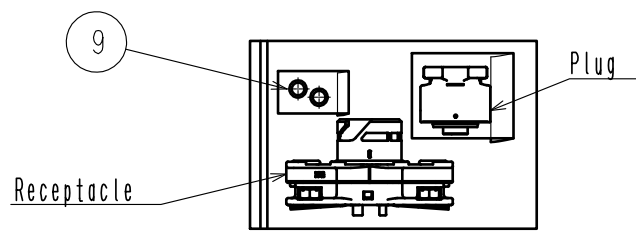

3 View of signal contact side

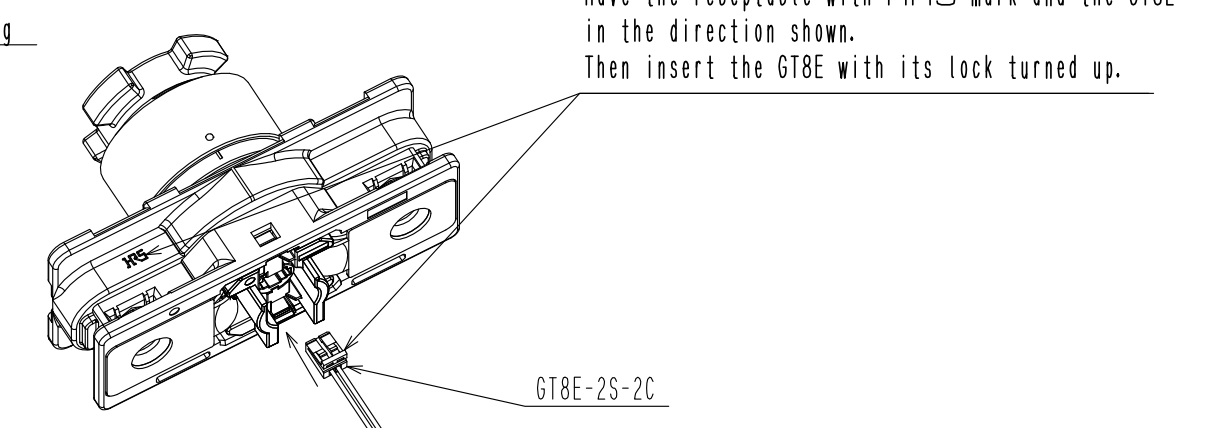

9 Table.1 Connection Timing (Power line and signal line)

(A)-(B) Power line  
 (C)-(D) Signal line

State	Before mating	Insertion plug	Rotated and Locked	Unlocked	Unmated
Appearance					
Connection		Power line closed. Signal line open. No power current.	Signal line closed. Power line ON	Signal line open. Power line OFF.	
Circuit diagram					

## Данный компонент на территории Российской Федерации

### Вы можете приобрести в компании MosChip.

Для оперативного оформления запроса Вам необходимо перейти по данной ссылке:

<http://moschip.ru/get-element>

Вы можете разместить у нас заказ для любого Вашего проекта, будь то серийное производство или разработка единичного прибора.

В нашем ассортименте представлены ведущие мировые производители активных и пассивных электронных компонентов.

Нашей специализацией является поставка электронной компонентной базы двойного назначения, продукции таких производителей как XILINX, Intel (ex.ALTERA), Vicor, Microchip, Texas Instruments, Analog Devices, Mini-Circuits, Amphenol, Glenair.

Сотрудничество с глобальными дистрибьюторами электронных компонентов, предоставляет возможность заказывать и получать с международных складов практически любой перечень компонентов в оптимальные для Вас сроки.

На всех этапах разработки и производства наши партнеры могут получить квалифицированную поддержку опытных инженеров.

Система менеджмента качества компании отвечает требованиям в соответствии с ГОСТ Р ИСО 9001, ГОСТ РВ 0015-002 и ЭС РД 009

### Офис по работе с юридическими лицами:

105318, г.Москва, ул.Щербаковская д.3, офис 1107, 1118, ДЦ «Щербаковский»

Телефон: +7 495 668-12-70 (многоканальный)

Факс: +7 495 668-12-70 (доб.304)

E-mail: [info@moschip.ru](mailto:info@moschip.ru)

Skype отдела продаж:

moschip.ru

moschip.ru\_4

moschip.ru\_6

moschip.ru\_9