

Multilayer ceramic capacitors

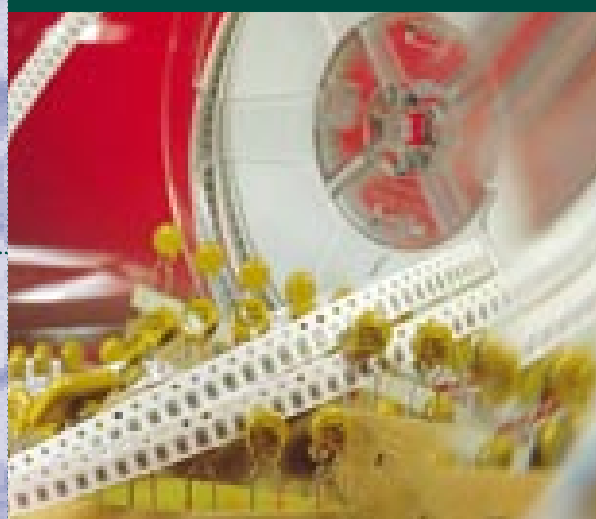

TPC, a subsidiary of THOMSON CSF, is a worldwide electronic component manufacturer, with over 40 years experience in ceramic capacitors and offers a complete package covering design, manufacture, just-in-time delivery and quality assurance for ceramic capacitors.

Our continued development in new materials and improved technology enables us to extend the range of products described in this brochure.

Our Sales, Marketing and Product Development Departments will provide you with full technical support to meet your requirements and help you for customized product design.



SAINT-APOLLINAIRE (France)



PENANG (Malaysia)

Information furnished is believed to be accurate and reliable. However THOMSON CSF PASSIVE COMPONENTS assumes no responsibility for the consequences of use of such information nor for any infringement of patents or other rights of third parties which may result from its use. No licence is granted by implication or otherwise under any patent or patent rights of TPC. Specifications mentioned in this publication are subject to change without notice. This publication supersedes and replaces all information previously supplied. © 1997 TPC - Printed in France - All rights reserved. These products are manufactured and commercialized by TPC.

Contents

Introduction

General characteristics	p. 4
Dielectric characteristics and classification	p. 6

How to order	p. 8
--------------	------

Selection guide	p. 9
-----------------	------

Radial moulded multilayer ceramic capacitors

MC04/05/08/10C - CE11/13-CE61/62/63/64	p. 10
MC04/05/08/10G - CN30/31-CN61/62/63/64	
MJ05/08G - CN19	p. 12
MK05/06C - CC05/CC06	p. 14
MK05/06G - CK05/CK06	
MQ05C	p. 16
MQ05/06G - CN50/CN60	

Radial dipped multilayer ceramic capacitors ("ECOCAP")

EC04/05/08C - CE72/73/74 - CE77/78/79	p. 18
EC04/05/08G - CN77/78/79	
EC04/05/08Z - CN72/73/74	
EC04/05/08W	

Taping characteristics	p. 20
------------------------	-------

Packaging	p. 22
-----------	-------

Recommendation for use	p. 23
------------------------	-------

Manufacturing process and quality assurance	p. 24
---	-------

Quality and Reliability	p. 26
-------------------------	-------

World wide sales offices	p. 28
--------------------------	-------

Introduction

GENERAL CHARACTERISTICS

The real characteristics of a capacitor can be described using conventional physical parameters and an equivalent electrical circuit displayed hereafter :

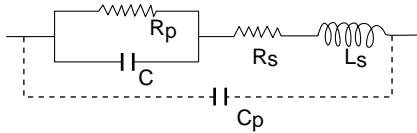

C the capacitance measures the capacitor aptitude to store electrical charges Q under a voltage V : $Q = C.V$

C_R the rated capacitance is obtained according to the building of the capacitor.

K the dielectric constant, specific to each material (less than 100 for type I materials, from 2000 up to 10 000 for type II materials),

S the surface of the electrodes,

t the thickness of the dielectric layer ; these parameters determine the value of the capacitor

$$C = K \frac{S}{t}$$

T.C. the temperature coefficient of the capacitance is expressed in ppm/°C for stable type I dielectrics.

°C/C is used for type II dielectrics and is expressed in % of change of the capacitance in a fixed temperature range.

U_R the rated voltage is the maximum voltage that can be applied to the capacitor in continuous operation.

It can be constituted by :

U_{DC} a direct current component

U_{AC} an alternative component with

U_P the peak voltage.

U_E the test voltage guarantees that the capacitor withstands U_R with a sufficient safety margin.

R_p represents the global losses (Polarization losses + insulation losses).

Under DC voltage the parallel resistance is reduced to :

R_i the insulation resistance, and measures the imperfection of the dielectric.

R_S or ESR (Equivalent Series Resistance) accounts for the imperfection of the conductivity of the electrodes and connections.

L_S or series inductance depends on the geometry of electrodes and connections, leads length ...

C_p takes into account dielectric environment of the capacitor (coating ...) but is generally neglected except to describe very high frequency behaviour of the capacitor.

R_p, R_s, L_s, C_p can be considered as parasitic effects. They generate energy losses and a dephasing

φ between voltage and current slightly different of 90°. The loss angle $\delta = (90^\circ - \varphi)$ is commonly used with

tg δ the tangent of loss angle which is also called :
DF or dissipation factor.

Q the quality factor is the ratio between the stored energy and the dissipated energy. It measures the quality of the capacitor and can be expressed as $Q = 1/\text{tg } \delta$

F being the frequency of the AC signal and

ω the pulsation of this signal with $\omega = 2 \pi F$

Z the complex impedance of the capacitor is therefore given by the relation (neglecting C_p) :

$$Z = R_s + j L_s \omega + \frac{1}{\frac{1}{R_p} + j C \omega} = R + j X$$

(the tangent of the loss angle $\text{tg } \delta$ can also be expressed as $\text{tg } \delta = \frac{R}{X}$

so, neglecting L_S for $L_S \omega < \frac{1}{C \omega}$

$$\text{tg } \delta = R_s C \omega + \frac{1}{R_p C \omega} + \frac{1}{R_p^2 C \omega}$$

F_{RS} the series resonance frequency of the capacitor is the frequency where the capacitance reactance is exactly compensated by the inductive reactance due to L_s

$$L_s \omega = \frac{1}{C \omega} \text{ or } \omega = \frac{1}{\sqrt{L_s C}} \text{ or } F_{RS} = \frac{1}{2\pi \sqrt{L_s C}}$$

F_{RP} the parallel resonance frequency occurs when L_s is compensated by C_p :

$$F_{RP} = \frac{1}{2\pi \sqrt{L_s C_p}}$$

Between F_{RS} and F_{RP}, the capacitor reacts as an inductance, but still blocking DC.

Introduction

The equivalent electrical circuit can be simplified using approximations according to the frequency :

- At $F = F_{RS}$ the circuit is reduced to

$$Z = R_s$$

- For $F > F_{RS}$ but below F_{RS}

$$Z = R_s + 1/jC\omega$$

$$\text{tg } \delta = R_s C \omega$$

- For low frequencies $Z = \frac{1}{\frac{1}{R_p} + jC\omega}$

$$\text{tg } \delta = \frac{1}{R_p C \omega}$$

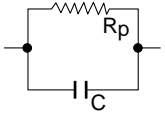
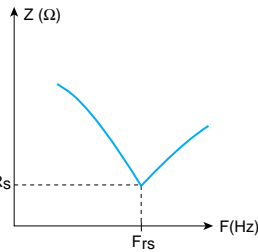

VERY HIGH FREQUENCIES BEHAVIOUR OF LEADED CAPACITORS

- Below the serie resonance frequency a radial MLC may be represented by this equivalent circuit :



- L_s is essentially due to the leads (shape, pitch and length)

$$L_s = L_1 (\text{chip}) + L_2 (\text{leads})$$

This parasitic inductance has a large impact on the serie resonance frequency :

$$F_r = \frac{1}{2\pi \sqrt{L_s C}} \quad \text{so } F_r \text{ is } \approx a \cdot \frac{1}{\sqrt{L_s}}$$

Parallel leads inductance calculation

$$L_s (\text{nH}) = 0.4 \ln \left[\frac{2.1P}{\phi} + 0.25 \frac{P}{1} \right]$$

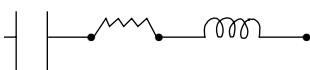

RELIABILITY

Ceramic capacitors reliability is related to two main factors :

• **A voltage derating** : life time is proportional to the power "n" of the derating applied :

$$\tau = a \left(\frac{U_{\text{rated}}}{U_{\text{use}}} \right)^n$$

$$n \approx 2 \text{ for NP0}$$

$$n \approx 3.4 \text{ for X7R}$$

THUS THE HIGHER $\left(\frac{U_{\text{rated}}}{U_{\text{use}}} \right)$ the longer the life.

• **A temperature derating** : life time is inversely proportional to the temperature of operation :

$$\tau = a \left(\frac{1}{T_{\text{use}}} - \frac{1}{T_{\text{rated}}} \right)$$

THUS THE LOWER the temperature of use, the longer the life.

Introduction

DIELECTRICS CHARACTERISTICS AND CLASSIFICATION

Dielectric	CECC EIA MIL	1B / CG COG / NPO COG / BP	2R1 X7R -	2C1 - BZ	2X1 - BX	2F4 Z5U -
TPC code		C	Z	G		W
TYPE		I	II			
Maximum capacitance change over temperature range No DC voltage applied		0 ± 30 ppm/°C	± 15 %	± 20 %	± 15 %	+ 30 % – 80 % + 22 % – 56 %
Rated DC voltage applied				+ 20 % – 30 %	+ 15 % – 25 %	+ 30 % – 90 %
Tangent of loss angle DF		$C_R > 50 \text{ pF}$ $\text{tg}\delta \ 15 \cdot 10^{-4}$ $5 \text{ pF} < C_R < 50 \text{ pF}$ $\text{Tg}\delta \ 1.5 \left(\frac{150}{C_R} + 7 \right) \cdot 10^{-4}$	$\text{Tg}\delta \ 250 \cdot 10^{-4}$			$\text{Tg}\delta \ 300 \cdot 10^{-4}$
Insulation resistance		$R_i \ 100 \text{ G}$ or $R_i \times C_R \ 1000 \text{ s}$				$R_i \ 10 \text{ G}$ $R_i \times C_R \ 100 \text{ s}$
Climatic category		55/125/56				25/085/56 10/085/56
Ageing (typical)		0 %	1 % per decade			5 % per decade

MEASUREMENT CONDITIONS

Reference temperature	20°C ± 1°C										
Test voltage	2.5 x U _R / 5 s and I _m < 50 mA										
Insulation resistance	U _m applied = rated voltage / 1 min										
Insulation resistance to earth	U = U _R x 2.5										
Measuring Frequency (Capacitance and tangent)	<table style="border: none; width: 100%;"> <tr> <td style="border: none;">- Type I : C_R 1000 pF</td> <td style="border: none;">⊗ F_m = 1 MHz</td> <td rowspan="2" style="border: none; vertical-align: middle;">} U_m = 1 V</td> </tr> <tr> <td style="border: none;">C_R > 1000 pF</td> <td style="border: none;">⊗ F_m = 1 kHz</td> </tr> <tr> <td style="border: none;">- Type II : C_R 100 pF</td> <td style="border: none;">⊗ F_m = 1 MHz</td> <td rowspan="2" style="border: none; vertical-align: middle;">} U_m = 0.5 V</td> </tr> <tr> <td style="border: none;">C_R > 100 pF</td> <td style="border: none;">⊗ F_m = 1 kHz</td> </tr> </table>	- Type I : C _R 1000 pF	⊗ F _m = 1 MHz	} U _m = 1 V	C _R > 1000 pF	⊗ F _m = 1 kHz	- Type II : C _R 100 pF	⊗ F _m = 1 MHz	} U _m = 0.5 V	C _R > 100 pF	⊗ F _m = 1 kHz
- Type I : C _R 1000 pF	⊗ F _m = 1 MHz	} U _m = 1 V									
C _R > 1000 pF	⊗ F _m = 1 kHz										
- Type II : C _R 100 pF	⊗ F _m = 1 MHz	} U _m = 0.5 V									
C _R > 100 pF	⊗ F _m = 1 kHz										

(With :U_m, I_m, F_m = Measuring parameters)

Introduction

DIELECTRICS CHARACTERISTICS AND CLASSIFICATION

Capacitance and tangent of loss angle as a function of temperature

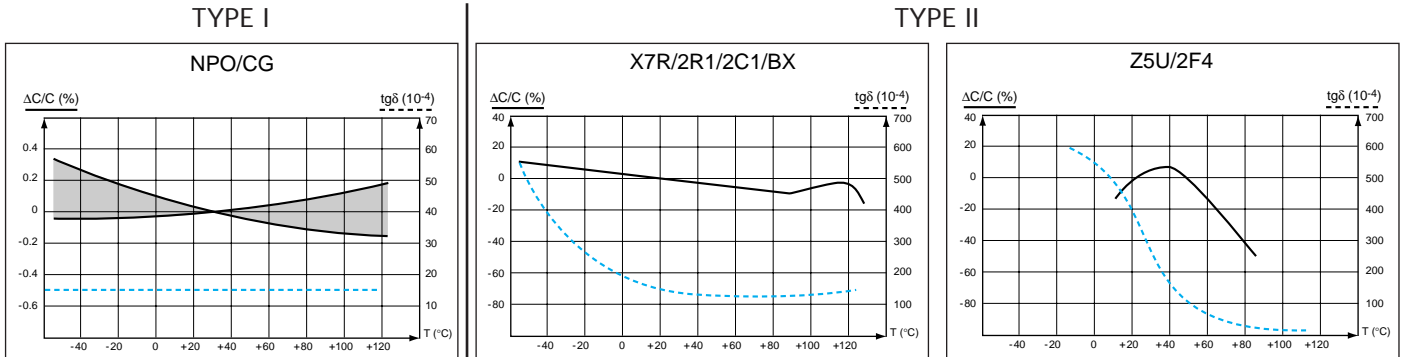

Capacitance and tangent of loss angle as a function of DC voltage

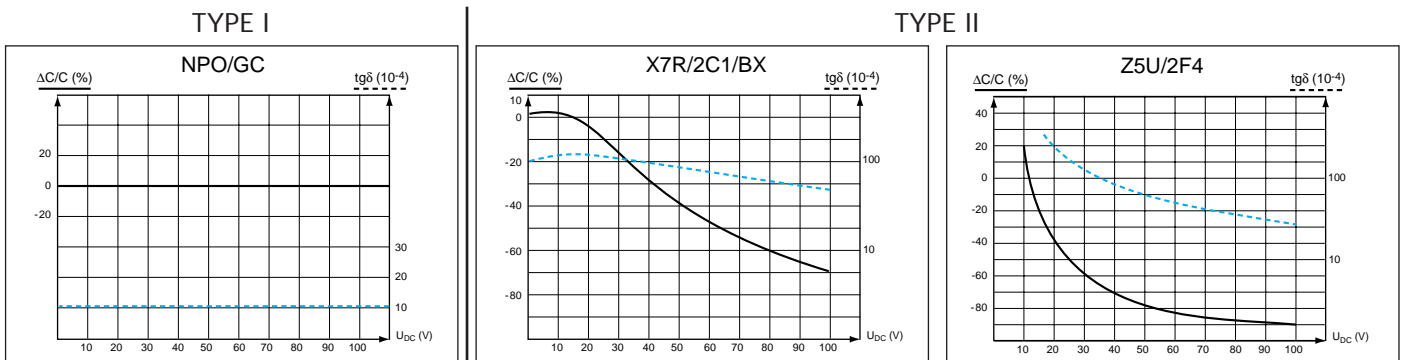

Capacitance and tangent of loss angle as a function of frequency

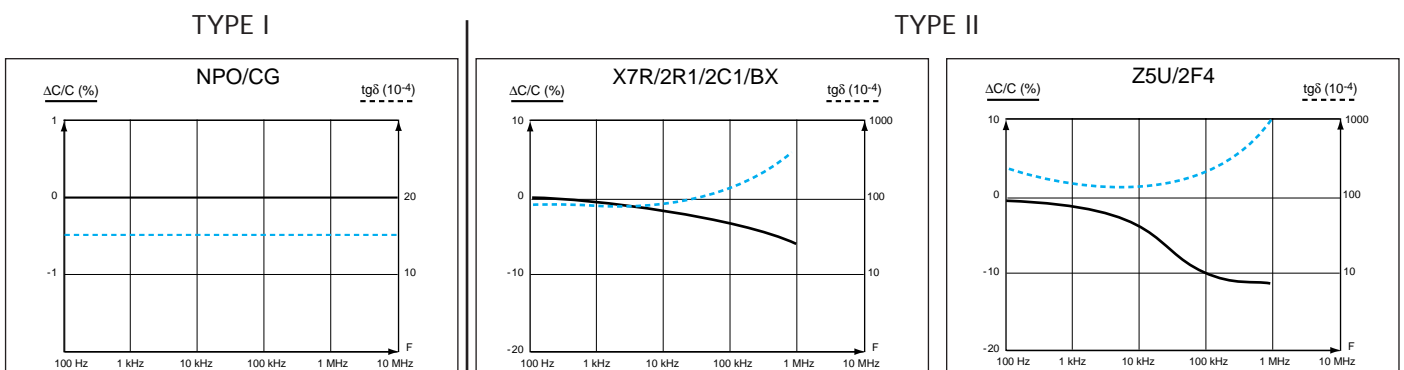

Capacitance as a function of time (ageing)

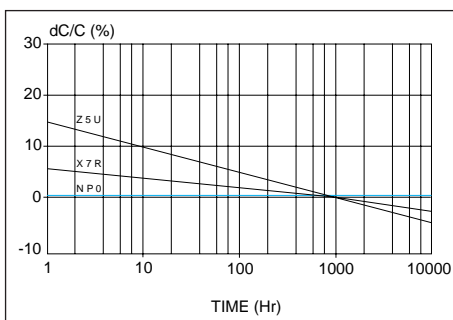

How to order

ORDERING EXAMPLE

1	2	3	4	5	6	7	8	9	10	11	12	13
E	C	0	4	Z	E	0	1	0	3	K	C	A

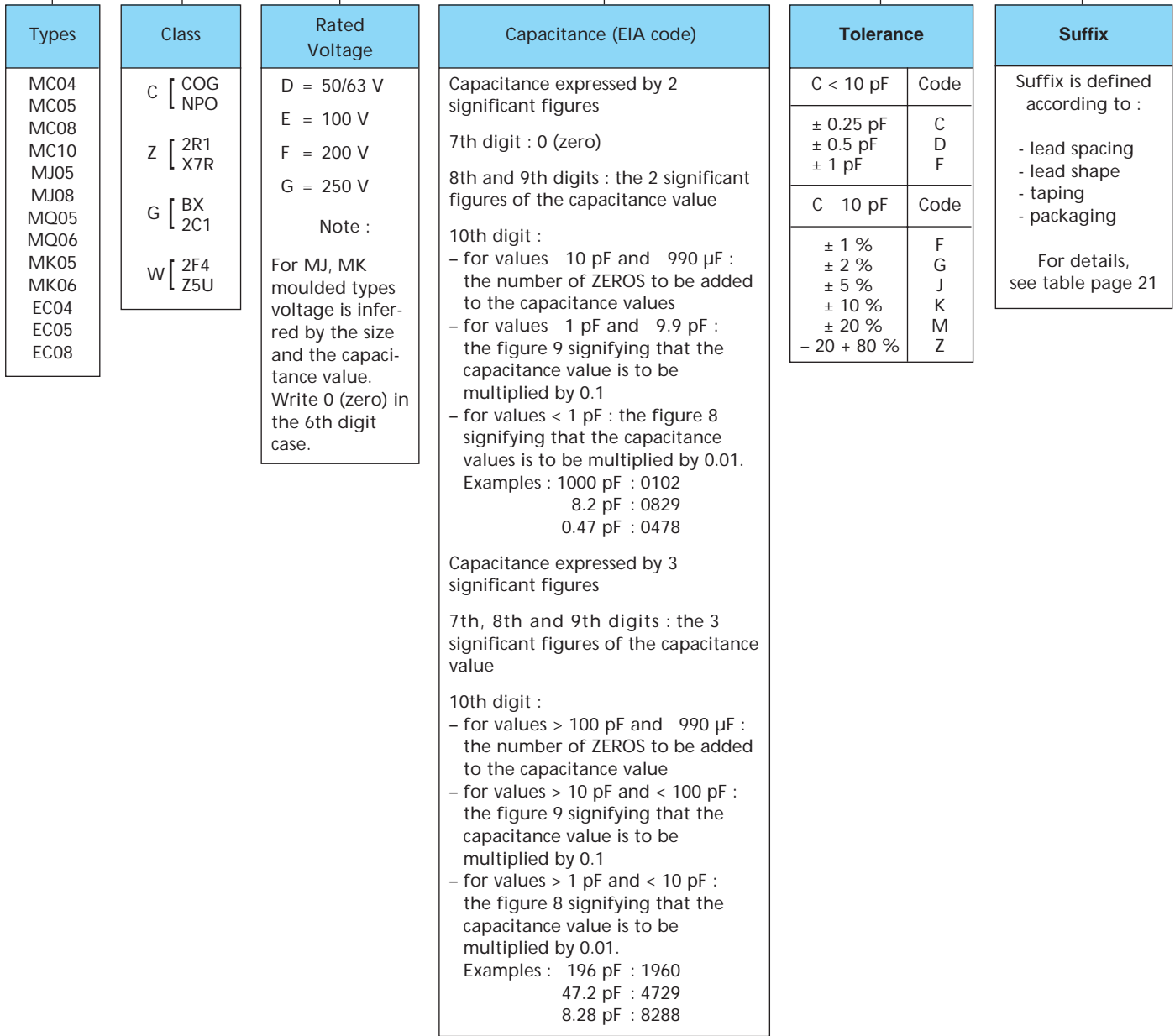

Selection guide

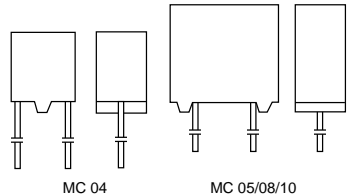
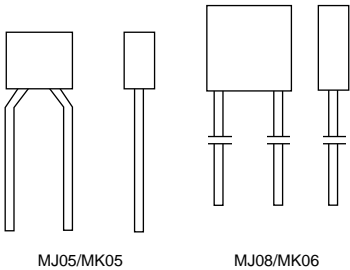
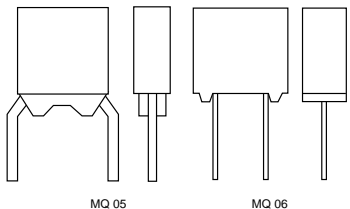
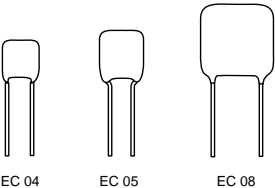
	Style	Types		Dielectric type/class	Electrical characteristics		Page		
		TPC	Standards CECC/MIL		Rated voltage	Capacitance range			
Moulded	 <p>MC 04 MC 05/08/10</p>	MC* 04/05/08/10	CE 13N/13L CE 11L CE 61/62/63/64	I - NPO/COG (C)	100 V	1 pF ... 10 nF	10/11		
					63 V	1 pF ... 33 nF			
			CE 31/31N CN 30 CN 61/62/63/64	II - 2C1 (G)	100 V	120 pF ... 330 nF			
					63 V	120 pF ... 1 µF			
					250 V	10 pF ... 10 nF			
					100 V	1.2 nF ... 100 nF			
	 <p>MJ05/MK05 MJ08/MK06</p>	MJ05/08 MK* 05/06	CN 19	II - 2C1 (G)	63 V	12 nF ... 1 µF	12/13		
					200 V	1 pF ... 2.2 nF			
			CC 05/06	I - NPO/COG (C)	100 V	1.1 nF ... 10 nF			
					50 V	4.3 nF ... 18 nF			
			CK 05/06	II - BX (G)	200 V	10 pF ... 10 nF			
					100 V	1.2 nF ... 100 nF			
 <p>MQ05 MQ06</p>	MQ05/06	-	I - NPO/COG (C)	50 V	12 nF ... 1 µF	14/15			
				200 V	1 pF ... 220 pF				
				100 V	1 pF ... 1 nF				
		CN 50/60	II - 2C1 (G)	250 V	10 pF ... 10 nF				
				100 V	1.2 nF ... 100 nF				
				63 V	12 nF ... 1 µF				
Radial Dipped	 <p>EC 04 EC 05 EC 08</p>	EC 04/05/08	CE 72/73/74 CE 77/78/79	I - NPO/COG (C)	200 V	4.7 pF ... 10 nF**	18/19		
					100 V	4.7 pF ... 27 nF**			
					50/63 V	820 pF ... 47 nF**			
		EC 04/05/08	CN 77/78/79			II - 2C1 (G)		100 V	1 nF ... 470 nF**
								50/63 V	10 nF ... 1 µF**
		EC 04/05/08	CN 72/73/74			II - X7R 2R1 (Z)		200 V	820 pF ... 330 nF**
								100 V	1 nF ... 1 µF**
								50/63 V	10 nF ... 1 µF**
		EC 04/05/08	-			II - Z5U/2F4 (W)		200 V	100 nF ... 680 nF**
								100 V	10 nF ... 2.2 µF**
								50/63 V	33 nF ... 3.3 µF**

* High reliability

Multilayer capacitors, especially moulded types can be produced in high reliability versions, according to the current ESA/SCC specifications and levels. Our MC and MK types appear on the European Space Agency qualified part list.

** Range extension

For high capacitance values and larger sizes, see catalogue "Ceramic capacitors for professional applications".

MC 04-05-08-10

NPO : CE/11L-13L-13N-61-61N-62-62N-63-64
 2C1 : CN/30-31-31N-61-61N-62-62N-63-64

Size

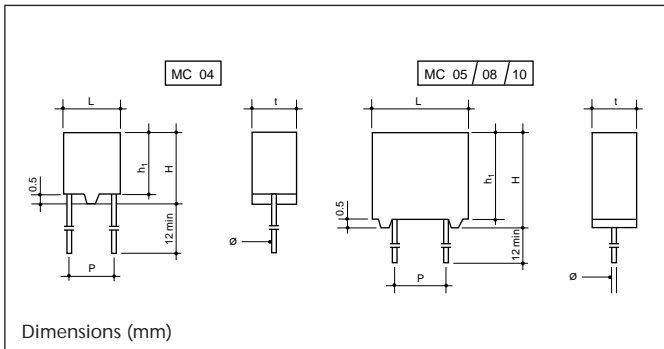

CECC APPROVALS :
NPO : 30601 - 001 2C1 : 30701 - 011
OPL : LNZ

Dimensions (mm)

Type	L ± 0.5	H max	h1 ± 0.5	t ± 0.2	Ø ± 5%	P ± 0.2	Obs.
MC04	3.5	4.5	3.5	2.5	0.6	2.54	
MC04	3.5	4.5	3.5	2.5	0.6	5.08	SUFFIX HB
MC05	5	6	5	2.5	0.6	2.54	
MC05	5	6	5	2.5	0.6	5.08	SUFFIX HB
MC08	7.5	8.5	7.5	2.5	0.6	5.08	
MC10	10	11	10	3.5	0.8	5.08	

TPC TYPE	CECC TYPES	
	NPO	2C1
MC04C ... MC04C ... HB	CE13L - CE61 CE13N - CE61N	
MC04G ... MC04G ... HB		CN31 - CN61 CN31N - CN61N
MC05C ... MC05C ... HB	CE13L - CE62 CE13N - CE62N	
MC05G ... MC05G ... HB		CN31 - CN62 CN31N - CN62N
MC08C ... MC08G ...	CE13L - CE63	CN30/31 - CN63
MC10C ... MC10G ...	C11L/13L - CE64	CN30/31 - CN64

Marking

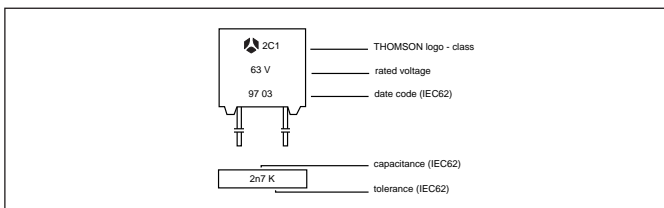

Capacitance tolerances & associated series	
NPO	2C1
C < 10 pF ± 0.25 pF : E12 ± 0.5 pF : E12	
C 10 pF ± 1 % : E96 ± 2 % : E48 ± 5 % : E24 ± 10 % : E12	± 5 % : E24 ± 10 % : E12 ± 20 % : E6

MC 04-05-08-10

NPO : CE/11L-13L-13N-61-61N-62-62N-63-64

2C1 : CN/30-31-31N-61-61N-62-62N-63-64

Dielectric Class		NPO								2C1							
Size		04		05		08		10		04		05		08		10	
Voltage		100 V	63 V	100 V	63 V	100 V	63 V	100 V	63 V	100 V	63 V	100 V	63 V	100 V	63 V	100 V	63 V
Cap. range	Code																
1.0 pF	0109																
1.2	0129																
1.5	0159																
1.8	0189																
2.2	0229																
2.7	0279																
3.3	0339																
3.9	0399																
4.7	0479																
5.6	0569																
6.8	0689																
8.2	0829																
10	0100																
12	0120																
15	0150																
18	0180																
22	0220																
27	0270																
33	0330																
39	0390																
47	0470																
51	0510																
56	0560																
68	0680																
82	0820																
100	0101																
120	0121																
150	0151																
180	0181																
220	0221																
270	0271																
330	0331																
390	0391																
470	0471																
560	0561																
680	0681																
750	0751																
820	0821																
1.0 nF	0102																
1.2	0122																
1.5	0152																
1.8	0182																
2.2	0222																
2.7	0272																
3.3	0332																
3.9	0392																
4.7	0472																
5.6	0562																
6.8	0682																
8.2	0822																
10	0103																
12	0123																
15	0153																
18	0183																
22	0223																
27	0273																
33	0333																
39	0393																
47	0473																
56	0563																
68	0683																
82	0823																
100	0104																
120	0124																
150	0154																
180	0184																
220	0224																
270	0274																
330	0334																
390	0394																
470	0474																
560	0564																
680	0684																
820	0824																
1.0 μF	0105																

Size

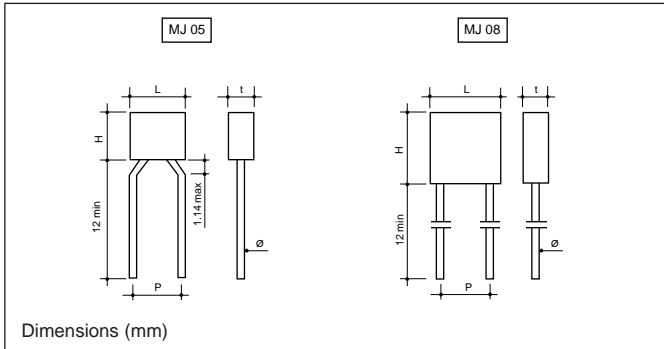

APPROVALS :
 CECC : 30701 - 016
 QPL : LNZ

Capacitance tolerances & associated series
 ± 5 % : E24
 ± 10 % : E12
 ± 20 % : E6

Dimensions (mm)

Type	L ± 0.2	H ± 0.2	t ± 0.2	Ø ± 5%	P ± 0.2
MJ05	4.8	4.8	2.3	0.6	5.08
MJ08	7.4	7.4	2.3	0.6	5.08

Marking

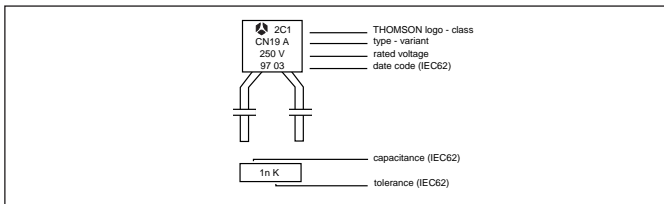

Dielectric Class			2C1					
Size			05			08		
Voltage			250 V	100 V	63 V	250 V	100 V	63 V
Cap. range	Code							
10 pF	0100							
12	0120							
15	0150							
18	0180							
22	0220							
27	0270							
33	0330							
39	0390							
47	0470							
56	0560							
68	0680							
82	0820							
100	0101							
120	0121							
150	0151							
180	0181							
220	0221							
270	0271							
330	0331							
390	0391							
470	0471							
560	0561							
680	0681							
820	0821							
1.0 nF	0102							
1.2	0122							
1.5	0152							
1.8	0182							
2.2	0222							
2.7	0272							
3.3	0332							
3.9	0392							
4.7	0472							
5.6	0562							
6.8	0682							
8.2	0822							
10	0103							
12	0123							
15	0153							
18	0183							
22	0223							
27	0273							
33	0333							
39	0393							
47	0473							
56	0563							
68	0683							
82	0823							
100	0104							
120	0124							
150	0154							
180	0184							
220	0224							
270	0274							
330	0334							
390	0394							
470	0474							
560	0564							
680	0684							
820	0824							
1.0 μF	0105							

MK 05-06

NPO : CC05-06
 BX : CK05-06

Size

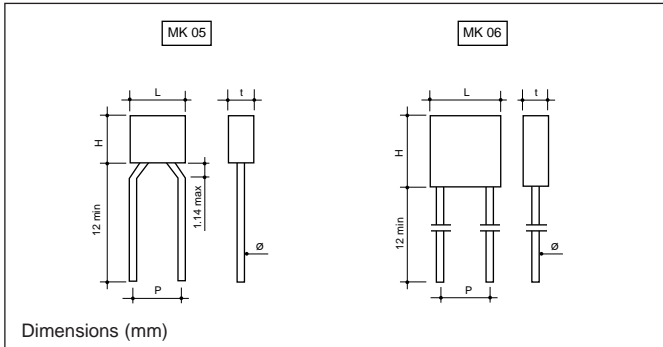

STANDARDIZATION :

NPO : MIL-C-20 8 CC05 - CC06
 BX : MIL-C11015D 8 CK05 - CK06

Dimensions (mm)

Type	L ± 0.2	H ± 0.2	t ± 0.2	Ø ± 5%	P ± 0.2
MK05	4.8	4.8	2.3	0.6	5.08
MK06	7.4	7.4	2.3	0.6	5.08

Capacitance tolerances & associated series

NPO	BX
C < 10 pF ± 0.25 pF : E12 ± 0.5 pF : E12	
C 10 pF ± 1 % : E96 ± 2 % : E48 ± 5 % : E24 ± 10 % : E12	± 5 % : E24 ± 10 % : E12 ± 20 % : E6

Marking / NPO

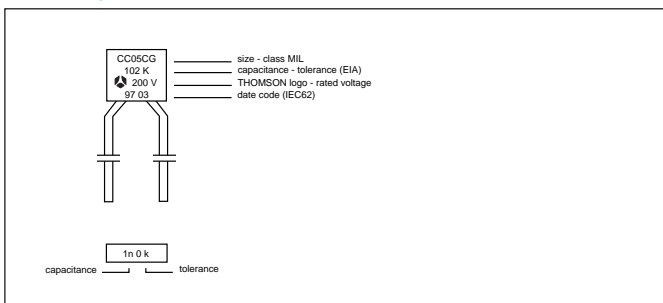

Marking / BX

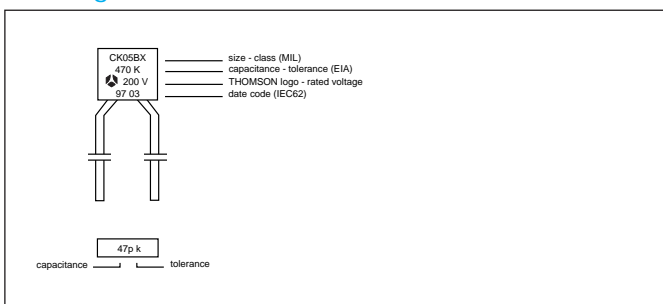

Dielectric Class		NPO						BX					
Size		05			06			05			06		
Voltage		200 V	100 V	50 V	200 V	100 V	50 V	200 V	100 V	50 V	200 V	100 V	50 V
Cap. range	Code												
1.0 pF	0109												
1.2	0129												
1.5	0159												
1.8	0189												
2.2	0229												
2.7	0279												
3.3	0339												
3.9	0399												
4.7	0479												
5.6	0569												
6.8	0689												
8.2	0829												
10	0100												
12	0120												
15	0150												
18	0180												
22	0220												
27	0270												
33	0330												
39	0390												
47	0470												
56	0560												
68	0680												
82	0820												
100	0101												
120	0121												
150	0151												
180	0181												
220	0221												
270	0271												
330	0331												
360	0361												
390	0391												
470	0471												
560	0561												
680	0681												
820	0821												
1.0 nF	0102												
1.2	0122												
1.5	0152												
1.8	0182												
2.2	0222												
2.4	0242												
2.7	0272												
3.3	0332												
3.9	0392												
4.3	0432												
4.7	0472												
5.6	0562												
6.8	0682												
8.2	0822												
10	0103												
12	0123												
15	0153												
18	0183												
22	0223												
27	0273												
33	0333												
39	0393												
47	0473												
56	0563												
68	0683												
82	0823												
100	0104												
120	0124												
150	0154												
180	0184												
220	0224												
270	0274												
330	0334												
390	0394												
470	0474												
560	0564												
680	0684												
820	0824												
1.0 μF	0105												

MQ 05-06

NPO : -
2C1 : CN50-60

Size

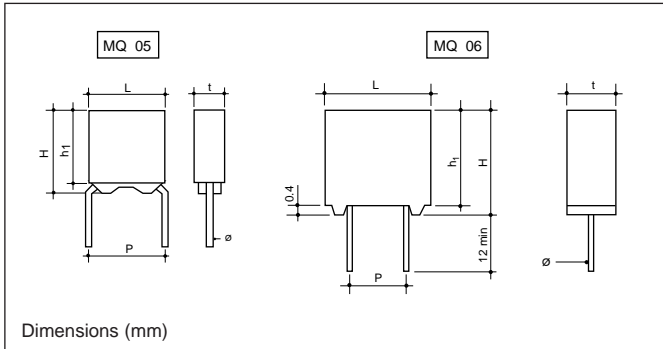

<p>APPROVALS :</p> <p>CECC 30701-016</p>
<p>QPL GAM-T1</p>

Dimensions (mm)

Model	Type	L ± 0.2	H ± 0.2	h ₁ ± 0.2	t ± 0.2	Ø ± 5%	P ± 0.2
CN50	MQ05	5	5	3.8	2.3	0.6	5.08
CN60	MQ06	7.5	7.5	7.1	2.3	0.6	5.08

Capacitance tolerances & associated series	
NPO	2C1
<p>C < 10 pF</p> <p>± 0.25 pF : E12</p> <p>± 0.5 pF : E12</p>	<p>± 5 % : E24</p> <p>± 10 % : E12</p> <p>± 20 % : E6</p>
<p>C 10 pF</p> <p>± 1 % : E96</p> <p>± 2 % : E48</p> <p>± 5 % : E24</p> <p>± 10 % : E12</p>	

Marking

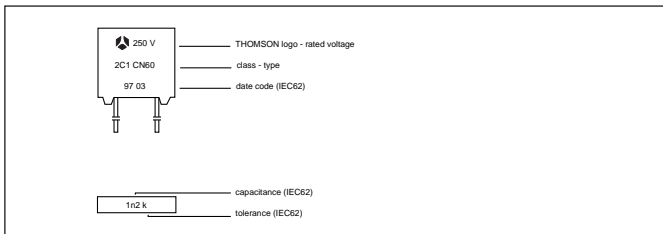

Dielectric Class		NPO		2C1					
Size		05		05			06		
Voltage		200 V	100 V	250 V	100 V	63 V	250 V	100 V	63 V
Cap. range	Code								
1.0 pF	0109								
1.2	0129								
1.5	0159								
1.8	0189								
2.2	0229								
2.7	0279								
3.3	0339								
3.9	0399								
4.7	0479								
5.6	0569								
6.8	0689								
8.2	0829								
10	0100								
12	0120								
15	0150								
18	0180								
22	0220								
27	0270								
33	0330								
39	0390								
47	0470								
56	0560								
68	0680								
82	0820								
100	0101								
120	0121								
150	0151								
180	0181								
220	0221								
270	0271								
330	0331								
390	0391								
470	0471								
560	0561								
680	0681								
820	0821								
1.0 nF	0102								
1.2	0122								
1.5	0152								
1.8	0182								
2.2	0222								
2.7	0272								
3.3	0332								
3.9	0392								
4.7	0472								
5.6	0562								
6.8	0682								
8.2	0822								
10	0103								
12	0123								
15	0153								
18	0183								
22	0223								
27	0273								
33	0333								
39	0393								
47	0473								
56	0563								
68	0683								
82	0823								
100	0104								
120	0124								
150	0154								
180	0184								
220	0224								
270	0274								
330	0334								
390	0394								
470	0474								
560	0564								
680	0684								
820	0824								
1.0 μF	0105								

EC 04-05-08

CE/CN72-73-74 CE/CN77-78-79

Size

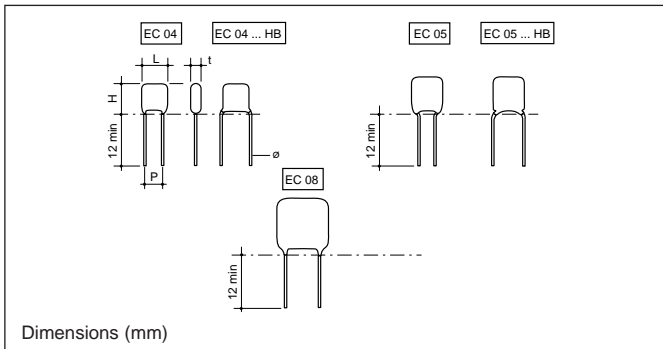

Dimensions (mm)

Type	Size	L max	H max	t max	Ø ± 10%	P +0.6 -0.1
EC04	04	3.8	5.3	2.5	0.5	2.54
EC04...HB	04	3.8	5.8	2.5	0.5	5.08
EC05	05	5	6.5	3.1	0.6	2.54
EC05...HB	05	5	7.5	3.1	0.6	5.08
EC08	08	7.6	9.6	3.8	0.6	5.08

Marking

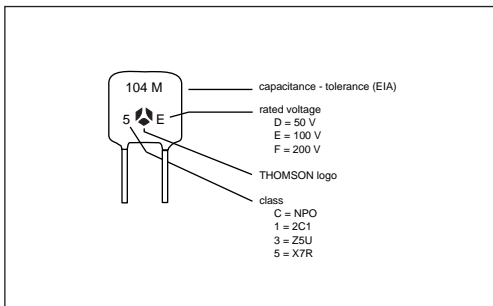

For EC04WD0104, marking is only "104"

Capacitance range - Type I

Dielectric Class	NPO								
	200 V			100 V			50 V		
Voltage	04	05	08	04	05	08	04	05	08
Capacitance									
4.7 to 470 pF									
560									
680									
820									
1 nF									
1.2									
1.5									
1.8									
2.2									
2.7									
3.3									
3.9									
4.7									
5.6									
6.8									
8.2									
10									
12									
15									
18									
22									
27									
33									
47									

APPROVALS
CECC : CECC 30601-015 : CE77/78/79 (NPO) CECC 30701-031 : CN77/78/79 (2C1) CECC 30701-045 : CN72/73/74 (2R1) CECC 30701-044 : EC04/05/08 (2F4)
QPL LNZ : CE & CN72/73/74
QPL GAM-T1 : CE & CN77/78/79

Types

TPC	CECC				EIA
	NPO	2C1	X7R	Z5U	
EC04	CE72.5 & CE77.5	CN77.5	CN72.5	-	CC15
EC04...HB	CE72.1 & CE77.1	CN77.1	CN72.1	-	-
EC05	CE73.5 & CE78.5	CN78.5	CN73.5	-	CC20
EC05...HB	CE73.1 & CE78.1	CN78.1	CN73.1	-	-
EC08	CE74.5 & CE79.5	CN79.5	CN74.5	-	CC30

Capacitance tolerances & associated series	
NPO :	C < 10 pF ± 0.25 pF (C) : E12 ± 0.5 pF (D) : E12
10 pF	C < 27 pf ± 5 % (J) : E24 ± 10 % (K) : E12
C	27 pF ± 1 % (F) : E96 ± 2 % (G) : E48 ± 5 % (J) : E24 ± 10 % (K) : E12
2C1 :	± 10 % (K) : E12 ± 20 % (M) : E6
X7R :	± 10 % (K) : E12 ± 20 % (M) : E6
Z5U :	± 20 % (M) : E6

Dielectric Class		2C1						X7R						Z5U											
Voltage		100 V			50 V			200 V			100 V			50 V			200 V			100 V			50 V		
Size		04	05	08	04	05	08	04	05	08	04	05	08	04	05	08	04	05	08	04	05	08	04	05	08
Cap. range	Code																								
0.82 nF	0821																								
1	0102																								
1.2	0122																								
1.5	0152																								
1.8	0182																								
2.2	0222																								
2.7	0272																								
3.3	0332																								
3.9	0392																								
4.7	0472																								
5.6	0562																								
6.8	0682																								
8.2	0822																								
10	0103																								
12	0123																								
15	0153																								
18	0183																								
22	0223																								
27	0273																								
33	0333																								
39	0393																								
47	0473																								
56	0563																								
68	0683																								
82	0823																								
100	0104																								
120	0124																								
150	0154																								
180	0184																								
220	0224																								
270	0274																								
330	0334																								
390	0394																								
470	0474																								
560	0564																								
680	0684																								
820	0824																								
1.0 μF	0105																								
1.2	0125																								
1.5	0155																								
1.8	0185																								
2.2	0225																								
2.7	0275																								
3.3	0335																								

Note : For higher capacitance values and larger sizes, see our catalogue "Ceramic capacitors for professional applications"

Taping characteristics

For automatic insertion, the following types can be ordered taped either in AMMOPACK or on REEL. For taped devices, it is necessary to specify the height (H or H_0) which is the distance between the tape axis (sprocket holes axis) and the sitting plane on the printed circuit board.

— Straight leads :

H represents the distance between the sprocket holes axe and the bottom plane of component body (base of resin or base of stand off).

— Kinked, flat and snap-in leads :

H_0 : distance between the sprocket holes axe and the base of the knee (kinked) or the bottom of the flat part (flat leads) or the waist.

CHARACTERISTICS OF THE TAPE (in accordance to IEC 286-2)

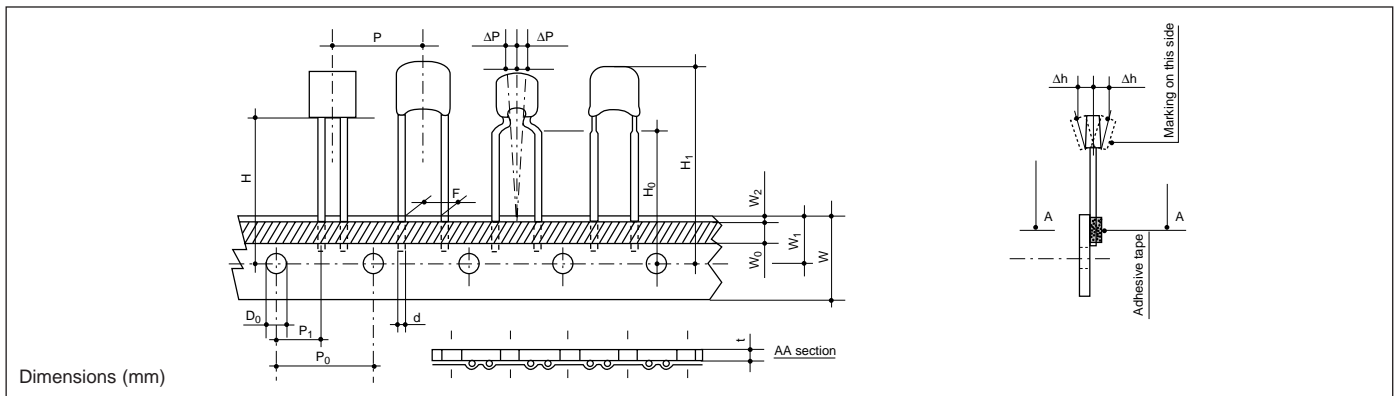

Value	Tolerance	Dimension characteristics	
18	+ 1 / - 0.5	W	Leading tape width
6	± 0.3	W_0	Adhesive tape width
9	+ 0.75 / - 0.5	W_1	Sprocket hole position
3 max		W_2	Distance between the tops of the tape and the adhesive
4	± 0.2	D_0	Diameter of sprocket hole
16/19.5	± 0.5	H_0	Distance between the tape axis and the seating plan of the component
30.5 max		H_1	Distance between the tape axis and the top of component body

Value	Tolerance	Dimension characteristics		
12.7	± 0.2	P_0	Sprocket holes pitch	
254	± 1	-	Distance between 21 consecutive holes 20 pitches	
0.7	± 0.2	1	Total thickness of tape	
2.54	5.08	+ 0.6 / - 0.1	F Lead spacing	
5.08	3.85	± 0.7	P_1 Distance between the sprocket hole axis and the lead axis	
12.7	± 1.0	P	Spacing of components	
0.5	0.6	0.63	± 10 %	d Lead diameter
0	± 1.3	$\text{°}P$	Verticality of components	
0	± 2	$\text{°}h$	Alignment of components	

REEL AND AMMOPACK PACKAGING

- A maximum of 3 consecutive components may be missing from the tape, surrounded by at least 6 filled positions. The number of missing components may not exceed 0.5 % of the total per packing module.
- The tape leader and trailer exhibit 8 or 9 blank positions.

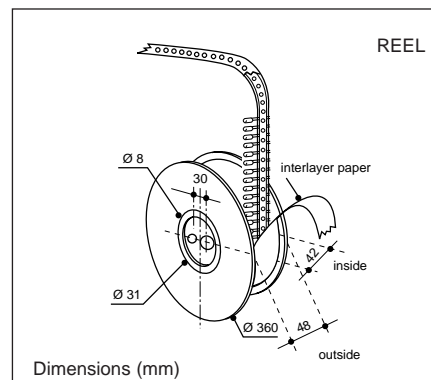
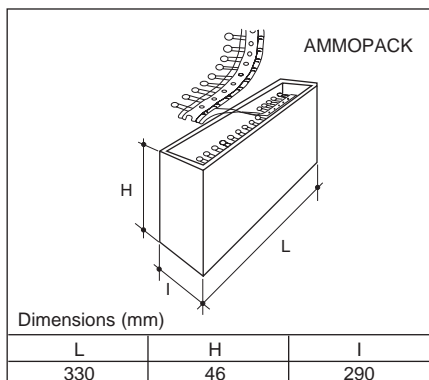

Taping characteristics

Table below indicates the suffixes to be specified when ordering to get the required kink and packaging (12th and 13th digits of the product codification).

Leads shape		Types	Packaging	Min. lead length (bulk) or taping height H_0 (± 0.5 mm)	Pitch	Suffix	
Straight		MC04/05	Bulk	12	2.54	--	
			Ammopack Reel	16	2.54	CA CB	
			Ammopack Reel	19.5	2.54	CC CD	
		MC08/MC10* MK06/MJ08	Bulk	12	5.08	--	
			Ammopack Reel	16	5.08	DA DB	
			Ammopack Reel	19.5	5.08	DC DD	
		MJ05 MK05	Bulk	12	5.08	--	
			Ammopack Reel	16	5.08	DA DB	
			Ammopack Reel	19.5	5.08	DC DD	
Straight		EC04 EC05	Bulk	12	2.54	--	
			Ammopack Reel	16	2.54	CA CB	
			Ammopack Reel	19.5	2.54	CC CD	
		EC08	Bulk	12	5.08	--	
			Ammopack Reel	16	5.08	DA DB	
			Ammopack Reel	19.5	5.08	DC DD	
Kinked		EC04 EC05	Bulk	12	5.08	HB	
			Ammopack Reel	16	5.08	DQ DR	
			Ammopack Reel	19.5	5.08	DS DT	
		EC08	Bulk	12	5.08	HL	
			Ammopack Reel	16	5.08	DL DM	
			Ammopack Reel	19.5	5.08	DN DP	
		EC04 EC05	Bulk	12	2.54	HE	
			Ammopack Reel	16	2.54	CE CF	
		EC04 EC05	Bulk	12	5.08	HK	
			Ammopack Reel	16	5.08	DE DF	
	Snap-in		EC04 EC05	Bulk	12	2.54	HG
				Ammopack Reel	16	2.54	CG CH
		EC04 EC05 EC08	Bulk	12	5.08	HH	
			Ammopack Reel	16	5.08	DG DH	
Flat		EC04 EC05	Bulk				
			Ammopack Reel	16	2.54	CJ CK	
			Ammopack Reel	19.5	2.54	CL CM	
		EC04 EC05 EC08	Bulk				
			Ammopack Reel	16	5.08	DZ D1	
			Ammopack Reel	19.5	5.08	D2 D3	

* MC10 : bulk only

Nota : Other lead lengths (for bulk products only) available upon request.

Packaging

PACKAGING QUANTITIES

Quantity per size				Specific packaging quantities
Type/Size	BULK	AMMOPACK	REEL	
MC04/MC05/MC08	500	2000	2000	* 3000 pieces for : EC05CE - 4700 pF - 5600 pF - 6800 pF EC05ZE/GE - 68 nF - 100 pF EC05WE - 220 nF - 330 nF - 470 nF EC05ZD - 150 nF - 220 nF EC05GD - 150 nF EC05WD - 470 nF - 680 nF - 1 μ F ** 2000 pieces for : EC08CE - 22 nF - 27 nF EC08ZE - 470 nF - 680 nF - 1 μ F EC08GE - 470 nF EC08ZD/GD - 1 μ F EC08WE - 1 μ F - 1.5 μ F - 2.2 μ F
MC10	250	2000	2000	
MJ05/MJ08	500	2000	2000	
MK05/MK06	500	2000	2000	
MQ05/MQ06	500	2000	2000	
EC04	5000	2500	4000	
EC05	5000	2500	3500*	
EC08	2000	1500	2500**	

IDENTIFICATION - TRACEABILITY

On every packaging, you will find a bar code label.

This label gives systematic information on the type of product, part number, lot number, manufacturing date and quantity.

An example is given below :

(H)Lot: **1A69721080 /006** **970610**
 (Q)Qty: **500**
 (2W)TPC-PN: **MJ08G00104K--**

Lot number
 Manufacturing date (YYMMDD)
 Quantity per packaging
 Part number

This information allows complete traceability of the entire manufacturing process, from raw materials to final inspection.

Recommendation for use

RADIAL LEAD TYPES EC04/EC05/EC08

During the solder immersion time it is advisable :

- To keep the leads free into the holes of the board.
- Not to apply any strength on the component (in line with the leads or across the body).
- To lift the body of the component, at least by 2 mm from the PCB (applicable for EC04 2.54 mm straight leads). The component should not be exposed to the solder heat for more than the "time versus temperature" given by the chart below.

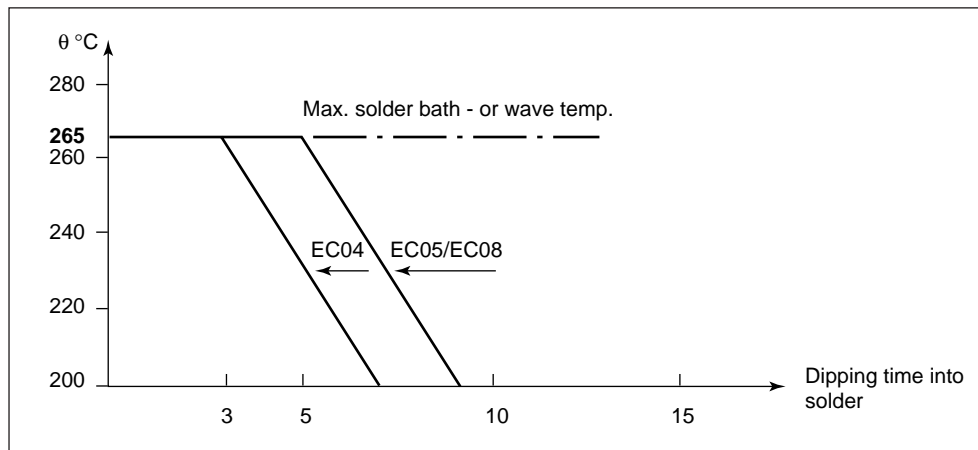

Manufacturing process and quality assurance

CHIPS MANUFACTURING FOR LEADED CAPACITORS

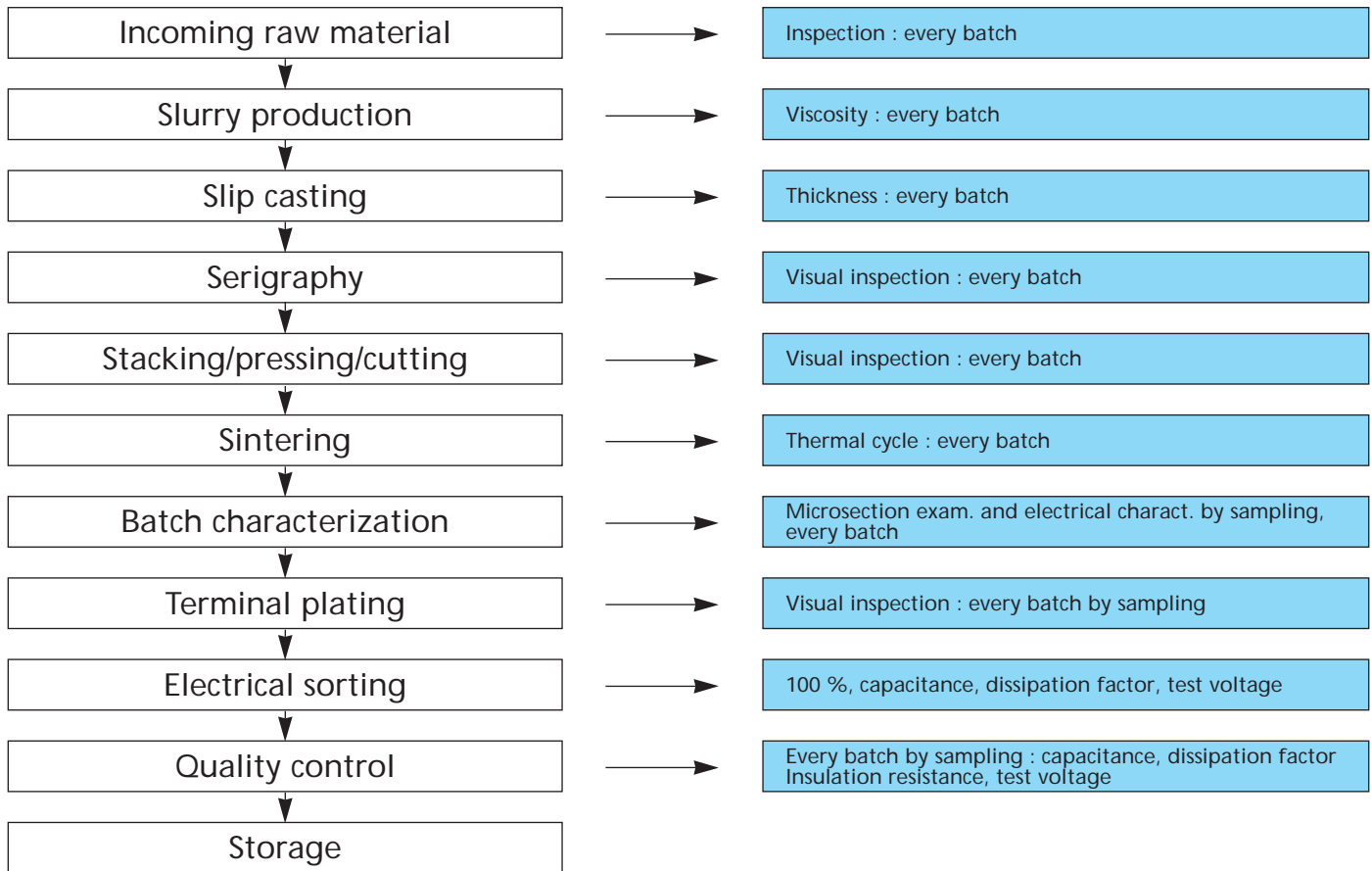

MANUFACTURING PROCESS FOR MOULDED CAPACITORS

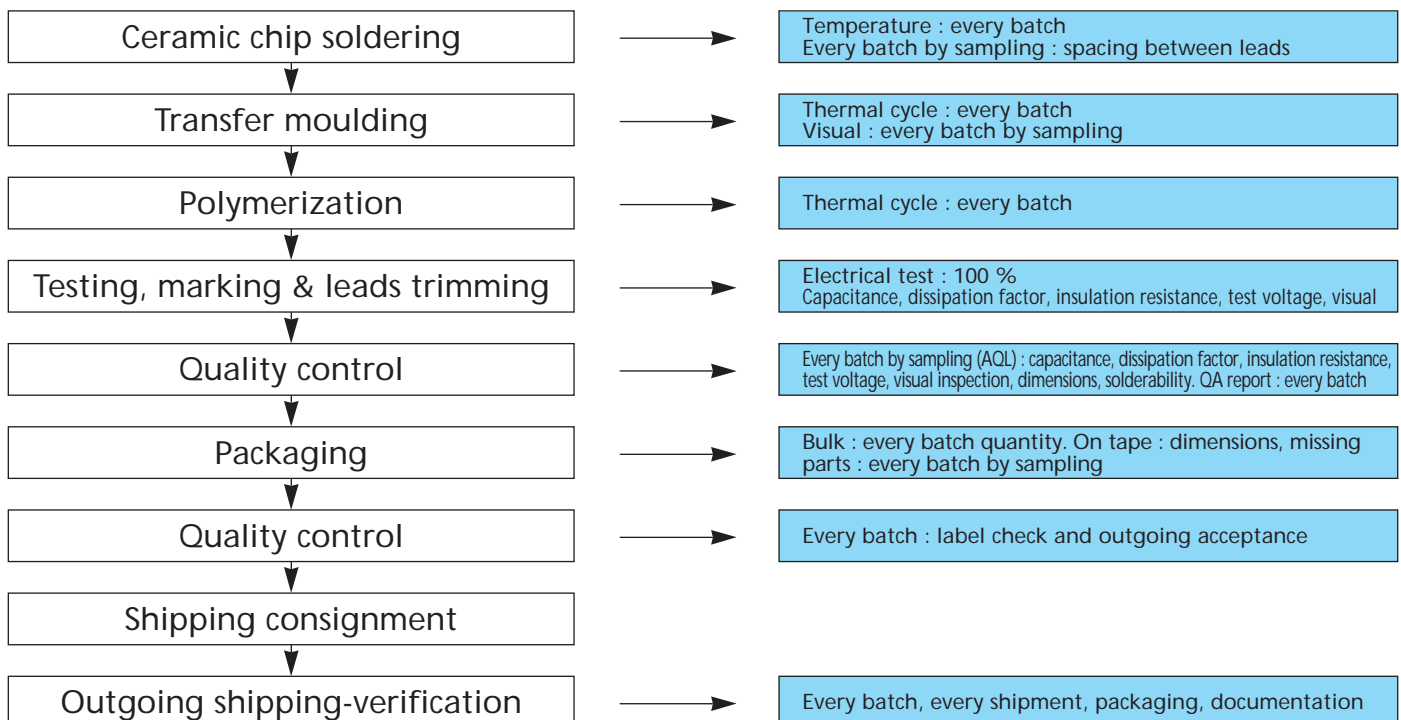

Manufacturing process and quality assurance

RADIAL DIPPED CAPACITORS MANUFACTURING PROCESS (EC Types)

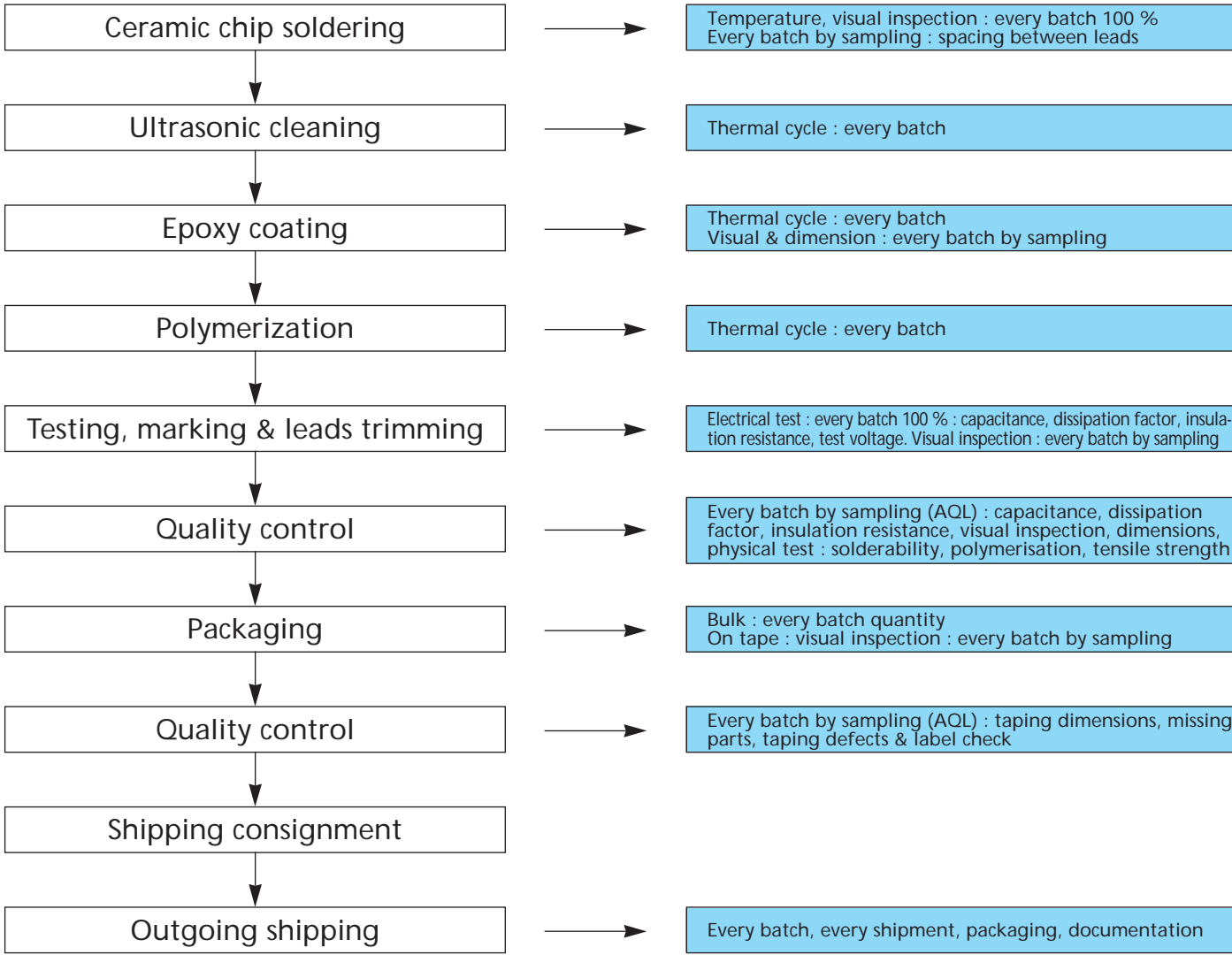

Quality and reliability

QUALITY SYSTEM

A high level of performance, quality and service has been achieved in setting up a quality system based on the ISO 9000 standard.

The system includes :

- a quality manual ensuring the proper organization,
- an incoming inspection,
- a manufacturing process control and a final inspection,
- reliability tests according to IEC 68, CECC 30600 and CECC 30700 standards,
- continuous improvements programs.

APPROVALS

The quality of our products and organization has been recognized by the following approvals :

* EC Types :

ISO 9002

Certificate of approval n° 928373

EN 100 114-1

Certificate of approval of manufacturer n° 004-96

CECC 30601 AND CECC 30701

See detailed data sheets on page 18

Qualified Parts List LNZ-44-04

Types CE 72/73/74 and CN 72/73/74

Qualified Parts List GAM-T1

Types CE 77/78/79 and CN 77/78/79

* Moulded types :

ISO 9001

Certificate of approval n° 928367

EN 100 114-1

Certificate of approval of manufacturer n° 032-93 issue 3

CECC 30601 and CECC 30701

See detailed data sheets on pages 10 to 16

Qualified Parts List LNZ-44-04

Types CN 19, CE 11/13

Qualified Parts List GAM-T1

Types CN 50/60

Quality and reliability

TEST DESCRIPTION	TEST CONDITION	TEST REQUIREMENT											
(1) ROBUSTNESS OF TERMINATIONS	IEC 68-2-21, Test Ua - Tensile Weight : 5 & 10N (Ecocap), Duration : 10 s (1 lead) IEC 68-2-21, Test Ub - Bending (same part different lead) 2 bends - in the same direction	<ul style="list-style-type: none"> No visible damage Crack along pant leg admissible 											
(2) RESISTANCE TO SOLDERING HEAT* IMMERSION IN SOLVENT (Sample from (1))	IEC 68-2-20, Test Tb - Resist. to sol. heat Immersion : 2.0 mm from component body Temp/Duration : 260°C/5 s IEC 68-2-46, Test Xa - Immersion in solvent Temp. / Duration : 23°C/5 min - 10 strokes Solvent : 2 - propanol, Weight : 5N	<ul style="list-style-type: none"> Marking legible No visible damage Delta C/C <table border="1"> <tr> <td>Class W 20 %</td> <td>Class Z 15 %</td> <td>Class G 10 %</td> <td>Class C 0.5 % or 0.5 pF</td> </tr> </table>	Class W 20 %	Class Z 15 %	Class G 10 %	Class C 0.5 % or 0.5 pF							
Class W 20 %	Class Z 15 %	Class G 10 %	Class C 0.5 % or 0.5 pF										
(3) RAPID CHANGE OF TEMP/ THERMAL SHOCK	IEC 68-2-14, Test Na - Thermal shock Ta=25°C (W), 55°C (C,G,Z) : Tb=85°C (W), 125°C (C,G,Z) Duration : 1 h/cycle ; nb of cycles : 5	<ul style="list-style-type: none"> No criteria 											
(4) VIBRATIONS (Sample from (3))	IEC 68-2-6, Test Fc - Vibration Freq range : 10...2000 Hz, amplitude : 0.75 mm Duration : 2 h/direction - 3 directions	<ul style="list-style-type: none"> No visible damage 											
(5) SHOCKS (Sample from (4))	IEC 68-2-27, Test Ea - Shock Pulse shape : half sine Acceleration : 490 m/s/s or 50 g Pulse duration : 11 ms 3 shocks x 3 directions	<ul style="list-style-type: none"> No visible damage Delta C/C : <table border="1"> <tr> <td>Class W 20 %</td> <td>Class Z 15 %</td> <td>Class G 10 %</td> <td>Class C 1.0 % or 1 pF</td> </tr> </table>	Class W 20 %	Class Z 15 %	Class G 10 %	Class C 1.0 % or 1 pF							
Class W 20 %	Class Z 15 %	Class G 10 %	Class C 1.0 % or 1 pF										
(6) CLIMATIC SEQUENCE (Sample from (2) & (5))	IEC 68-2-2, Test B - Dry heat Temp/Duration : 85°C (W), 125°C (C,G,Z)/16 h IEC 68-2-30, Test Db - Damp heat cycles Temp/Duration : 55°C/24 h Humidity : 95 % IEC 68-2-1, Test A - Cold Temp/Duration : 25°C (W), -55°C (C,G,Z)/2 h EC 68-2-30, Test Db - Damp heat cycles Duration : 24 h/remaining cycles Humidity 95 %, Temp : -55°C	<ul style="list-style-type: none"> Marking legible No visible damage Delta C/C : <table border="1"> <tr> <td>Class W 30 %</td> <td>Class Z 15 %</td> <td>Class G 10 %</td> <td>Class C 2.0 % or 1 pF</td> </tr> </table> <ul style="list-style-type: none"> DF 70x10⁻³ IR 1 G or 25 s/C <table border="1"> <tr> <td>70x10⁻³</td> <td>50x10⁻³</td> <td>2 x original limit</td> </tr> </table> <table border="1"> <tr> <td>1 G or 25 s/C</td> <td>1 G or 25 s/C</td> <td>10 G or 100 s/C</td> <td>10 G or 100 s/C</td> </tr> </table>	Class W 30 %	Class Z 15 %	Class G 10 %	Class C 2.0 % or 1 pF	70x10 ⁻³	50x10 ⁻³	2 x original limit	1 G or 25 s/C	1 G or 25 s/C	10 G or 100 s/C	10 G or 100 s/C
Class W 30 %	Class Z 15 %	Class G 10 %	Class C 2.0 % or 1 pF										
70x10 ⁻³	50x10 ⁻³	2 x original limit											
1 G or 25 s/C	1 G or 25 s/C	10 G or 100 s/C	10 G or 100 s/C										
(7) DAMP HEAT WITH VOLTAGE	IEC 68-2-3, Test Ca - Damp heat Temp/Duration : 40°C/56 days Humidity : 93 % RH Applied voltage : U _R	<ul style="list-style-type: none"> No visible damage Delta C/C : <table border="1"> <tr> <td>Class W 30 %</td> <td>Class Z 15 %</td> <td>Class G 15 %W/V 10 %W/out V</td> <td>Class C 2.0 % or 1 pF</td> </tr> </table>	Class W 30 %	Class Z 15 %	Class G 15 %W/V 10 %W/out V	Class C 2.0 % or 1 pF							
Class W 30 %	Class Z 15 %	Class G 15 %W/V 10 %W/out V	Class C 2.0 % or 1 pF										
(8) DAMP HEAT WITHOUT VOLTAGE	IEC 68-2-3, Test Ca - Damp heat Temp/Duration : 40°C/56 days Humidity : 93 % RH	<ul style="list-style-type: none"> DF 70x10⁻³ IR 1 G or 25 s/C <table border="1"> <tr> <td>70x10⁻³</td> <td>50x10⁻³</td> <td>2 x original limit</td> </tr> </table> <table border="1"> <tr> <td>1 G or 25 s/C</td> <td>1 G or 25 s/C</td> <td>10 G or 100 s/C</td> <td>10 G or 100 s/C</td> </tr> </table>	70x10 ⁻³	50x10 ⁻³	2 x original limit	1 G or 25 s/C	1 G or 25 s/C	10 G or 100 s/C	10 G or 100 s/C				
70x10 ⁻³	50x10 ⁻³	2 x original limit											
1 G or 25 s/C	1 G or 25 s/C	10 G or 100 s/C	10 G or 100 s/C										
(9) ENDURANCE/ LIFE TEST	(CECC 30000, 30600, 30601-016, 30700, 30701-031, 30701-045, 30701-044) Temp : 85°C (W), 125°C (C,G,Z) Duration : 1000 h Applied voltage : 1.5 U _R (2 U _R in particular cases)	<ul style="list-style-type: none"> No visible damage Delta C/C : <table border="1"> <tr> <td>Class W 30 %</td> <td>Class Z 15 %</td> <td>Class G -15 % ... +5 %</td> <td>Class C 3.0 % or 1 pF</td> </tr> </table> <ul style="list-style-type: none"> DF 70x10⁻³ IR 2 G or 50 s/C <table border="1"> <tr> <td>70x10⁻³</td> <td>50x10⁻³</td> <td>1.5 x original limit</td> </tr> </table> <table border="1"> <tr> <td>2 G or 50 s/C</td> <td>2 G or 50 s/C</td> <td>10 G or 100 s/C</td> <td>10 G or 100 s/C</td> </tr> </table>	Class W 30 %	Class Z 15 %	Class G -15 % ... +5 %	Class C 3.0 % or 1 pF	70x10 ⁻³	50x10 ⁻³	1.5 x original limit	2 G or 50 s/C	2 G or 50 s/C	10 G or 100 s/C	10 G or 100 s/C
Class W 30 %	Class Z 15 %	Class G -15 % ... +5 %	Class C 3.0 % or 1 pF										
70x10 ⁻³	50x10 ⁻³	1.5 x original limit											
2 G or 50 s/C	2 G or 50 s/C	10 G or 100 s/C	10 G or 100 s/C										
(10) C = (T) TEMP COEFFICIENT	(CECC 30000, 30600, 30601-016, 30700, 30701-031, 30701-045, 30701-044) Test temp : -25°C/+85°C (W), -55°C/+125°C (G,Z) -55°C/+85°C/+125°C (C)	<ul style="list-style-type: none"> Delta C/C : <table border="1"> <tr> <td>Class W +22 -56 % U_m = 0</td> <td>Class Z ± 15 % U_m = 0</td> <td>Class G +20 -30 % U_m = U_R ±20%, U_n=0</td> <td>Class C 0±30 ppm/°C U_m = 0</td> </tr> </table>	Class W +22 -56 % U _m = 0	Class Z ± 15 % U _m = 0	Class G +20 -30 % U _m = U _R ±20%, U _n =0	Class C 0±30 ppm/°C U _m = 0							
Class W +22 -56 % U _m = 0	Class Z ± 15 % U _m = 0	Class G +20 -30 % U _m = U _R ±20%, U _n =0	Class C 0±30 ppm/°C U _m = 0										

* Recovery : 1-2 h

Worldwide sales offices

AMERICAS

BRAZIL

THOMSON-CSF COMPONENTS BRASIL Ltda
Av. Prof. Vicente Rao, 1620
CEP 0436-001
SAO PAULO - BRASIL
Tel. : (5511) 5247713
Fax : (5511) 2473059

USA

THOMSON-CSF PASSIVE COMPONENTS U.S.
2211 - H Distribution Center Drive
CHARLOTTE NC 28269
Tel. : (1 704) 597 0766
Fax : (1 704) 597 0553

EUROPE

BENELUX

THOMSON-CSF PASSIVE COMPONENTS BENE-LUX
Avenue Louise 363 - B 10
B-1050 BRUXELLES
Tel. : (32 2) 627 03 45
Fax : (32 2) 627 03 33

INT'L SALES HEADQUARTER

France & other countries
THOMSON-CSF PASSIVE COMPONENTS
29, avenue Carnot
91349 MASSY Cedex France
Tel. : (33) 1 69 93 41 41
Fax : (33) 1 69 93 42 90

GERMANY

THOMSON-CSF PASSIVE COMPONENTS
Perchtinger Strasse 3
D-81379 MUNCHEN 70
Tel. : (49 89) 78 79 0
Fax : (49 89) 78 79 145

ITALY

THOMSON-CSF PASSIVE COMPONENTS
Viale Fulvio Testi, 117
20092 CINISELLO BALSAMO (MILANO)
Tel. : (39 2) 660 15 510
Fax : (39 2) 660 15 677

SPAIN AND PORTUGAL

THOMSON-CSF PASSIVE COMPONENTS
C/Principe de Vergara, 204 - 1°B
28002 MADRID
Tel. : (34) 1 564 02 72
Fax : (34) 1 564 19 40

U.K. AND IRELAND

THOMSON-CSF PASSIVE COMPONENTS
P.O Box 6254
Mountbatten House
Basing View
Basingstoke, RG 21 4XZ
ENGLAND
Tel. : (44) 1256 38 78 00
Fax : (44) 1256 38 78 40

ASIA

HONG KONG

THOMSON-CSF PASSIVE COMPONENTS ASIA Ltd
81F Rays Industrial Building
71 Hung to Road
Kwun Tong
KOWLOON - HONG KONG
Tel. : (852) 2389 00 22
Fax : (852) 2797 80 81

INDIA

THOMSON-CSF PASSIVE COMPONENTS ASIA Ltd
India Representative Office
C 310 blue cross chambers
Infantry road cross
BANGALORE - 560001 INDIA
Tel. : (91 80) 555 0566
Fax : (91 80) 555 0566

SINGAPORE

THOMSON-CSF PASSIVE COMPONENTS SINGAPORE Pte Ltd
171 Kallang Way n° 03-08
Kolam Ayer Industrial Park
SINGAPORE 349250
Tel. : (65) 741 90 88
Fax : (65) 741 92 88

SHANGHAI

THOMSON-CSF PASSIVE COMPONENTS ASIA Ltd
Representative Office
Room 6011 Hua Ting Guest House
2525 Zhong Shan Xi Lu
Shanghai 200030
CHINA
Tel. : (8621) 6481 4564
Fax : (8621) 6481 4544

TAIWAN

THOMSON-CSF PASSIVE COMPONENTS TAIWAN Ltd
12 F n° 149-16, Sec. 2
Keelung Road, Taipei 110
TAIWAN ROC
Tel. : (8862) 378 6792
Fax : (8862) 736 2142



*"Specifications mentioned in this publication
are subject to change without notice"*

Power capacitors



Soft ferrite



Film capacitors



Ceramic capacitors



Non linear resistors



Conception réalisation : SOREGRAPH, Crédits photos : Dominique SARRAUJE, Le Square des Photographes.

SPC 898 - 12/97 - Design : PILOTE Image.

 **THOMSON-CSF**
PASSIVE COMPONENTS

HEADQUARTERS : Avenue du Colonel Prat - 21850 Saint-Apollinaire - France - Tél. : (33) 03 80 71 74 00 - Fax : (33) 03 80 74 87 28 - Telex : THOM 616 780 F
SALES OFFICES : 29, avenue Carnot - 91349 Massy Cedex - France - Tél. : (33) 01 69 93 41 41 - Fax : (33) 01 69 93 40 92 Telex : THOM 616 780 F

Данный компонент на территории Российской Федерации

Вы можете приобрести в компании MosChip.

Для оперативного оформления запроса Вам необходимо перейти по данной ссылке:

<http://moschip.ru/get-element>

Вы можете разместить у нас заказ для любого Вашего проекта, будь то серийное производство или разработка единичного прибора.

В нашем ассортименте представлены ведущие мировые производители активных и пассивных электронных компонентов.

Нашей специализацией является поставка электронной компонентной базы двойного назначения, продукции таких производителей как XILINX, Intel (ex.ALTERA), Vicor, Microchip, Texas Instruments, Analog Devices, Mini-Circuits, Amphenol, Glenair.

Сотрудничество с глобальными дистрибьюторами электронных компонентов, предоставляет возможность заказывать и получать с международных складов практически любой перечень компонентов в оптимальные для Вас сроки.

На всех этапах разработки и производства наши партнеры могут получить квалифицированную поддержку опытных инженеров.

Система менеджмента качества компании отвечает требованиям в соответствии с ГОСТ Р ИСО 9001, ГОСТ РВ 0015-002 и ЭС РД 009

Офис по работе с юридическими лицами:

105318, г.Москва, ул.Щербаковская д.3, офис 1107, 1118, ДЦ «Щербаковский»

Телефон: +7 495 668-12-70 (многоканальный)

Факс: +7 495 668-12-70 (доб.304)

E-mail: info@moschip.ru

Skype отдела продаж:

moschip.ru

moschip.ru_4

moschip.ru_6

moschip.ru_9