



187 series

20-25 Amp Power Relays

File E38802

File LR54109

Users should thoroughly review the technical data before selecting a product part number. It is recommended that users also seek out the pertinent approvals files of the agencies/laboratories and review them to confirm the product meets the requirements for a given application.

Features

- AC coils 6-240VAC 50/60 Hz., DC 6-110VDC.
- One or two pole models with single or double throw contacts.
- 187 relays with 2 form A or 2 form B contacts are rated 25 amps; 187 relays with other contact arrangements are rated 20 amps.
- .250" combination quick connect/solder terminals or PC terminals.
- Various mounting options include stud, core, bracket, flange, PC board.
- Open-style relay or with dust cover.

Contact Data @ 25°C

Arrangements: 1 Form X (SPST-NO-DM), 1 Form Y (SPST-NC-DB), 2 Form C (DPDT), 2 Form A (DPST-NO) and 2 Form B (DPST-NC).

Material: Silver-cadmium oxide, .25" (6.5mm) dia. or Fine silver, .187" (4.75mm) dia.

Expected Mechanical Life: 10 million operations.

Initial Contact Resistance: 50 milliohms.

Contact Ratings

Contact Code & Description	UL Ratings	Expected Life
-200 1/4" (6.25 mm) Dia. Silver Cadmium Oxide	20A @ 120/240VAC 10A @ 480/600VAC 3/4 HP @ 120VAC, 1 1/2 HP @ 240VAC 2 HP @ 208/277VAC* 17FLA, 65LRA @ 300VAC 20A @ 28VDC	100,000 ops.
-500 3/16" (4.75 mm) Dia. Fine Silver	5A @ 120/240VAC 2A @ 480/600VAC 1/8 HP @ 120VAC, 1/4 HP @ 240VAC 2A (7.2A inrush) @ 24VAC 5A @ 28VDC	100,000 ops.
-600 1/4" (6.25 mm) Dia. Silver Cadmium Oxide	25A @ 120/240VAC 10A @ 480/600VAC 3/4 HP @ 120VAC, 1 1/2 HP @ 240VAC 2 HP @ 208/277VAC* 17FLA, 65LRA @ 300VAC	100,000 ops.

*2 HP rating at reduced electrical life, consult factory.

Initial Dielectric Strength

Between Open Contacts: >750V rms, 60 Hz.

Between All Other Mutually Isolated Elements: >2,500V rms, 60 Hz.

Coil Data @ 25°C

Voltage: 6-110VDC and 6-240VAC.

Nominal Power:

DC Coils: 1.2 Watts.

AC Coils: 3.0VA.

Duty Cycle: Continuous at up to 25% overvoltage.

Initial Insulation Resistance: 1,000 megohms, min. @ 500VDC

Insulation: Class B, 130°C.

Coil Data @ 25°C (continued)

Temperature Rise:

AC Coils:

Nominal Voltage: 35°C for open models.
45°C for enclosed models.

25% Overvoltage: 55°C for open models.
65°C for enclosed models.

DC Coils:

Nominal Voltage: 35°C for open models.
40°C for enclosed models.

25% Overvoltage: 50°C for open models.
55°C for enclosed models.

Coil Data

	Nominal Voltage	DC Resistance in Ohms ± 10%	Must Operate Voltage
DC Coils	6	32	4.5
	12	120	9.0
	24	470	18.0
	48	1,800	36.0
	110	11,000	82.5
AC Coils	6	4.2	5.1
	12	18	10.2
	24	72	20.4
	120	1,700	102.0
	208	5,400	176.8
	240	7,200	204.0

Operate Data @ 25°C

Must Operate Voltage:

DC Coils: 75% of nominal.

AC Coils: 85% of nominal.

Operate Time (Excluding Bounce): 20 milliseconds, max, at nominal voltage, no coil suppression.

Release Time (Excluding Bounce): 10 milliseconds, max, at nominal voltage, no coil suppression.

Environmental Data

Temperature Range (50/60 Hz operation, based on 105°C limit):

Operating

AC Coils: -45°C to +60°C for open models.
-45°C to +45°C for enclosed models.

DC Coils: -45°C to +80°C for open models.
-45°C to +70°C for enclosed models.

Storage

All: -65°C to +100°C.

Shock: 15g's, 11 ± 1 ms (non-operating, no mechanical damage).

Vibration: .1" double amplitude or 10 g's, 10-55 Hz. (operating, no contact chatter).

Mechanical Data

Termination: .250" quick connect/solder; and PC board.

Enclosure: Open or polycarbonate dust cover.

Weight: 3 oz. (86g) approximately.

Outline Dimensions

Typical Part No. > **187- 3 2 T 2 00**

1. Basic Series and Type: 187 = Open or Enclosed 20-25 Amp Power Relay.						
2. Enclosure and Terminals: 1 = Open, Solder/Quick Connect Terminals. 2 = Plain Enclosure with 6-32 Tapped Core, Solder/Quick Connect Terminals 3 = Flanged Enclosure, Solder/Quick Connect Terminals 4 = Plain Enclosure with Mounting Bracket and Stud on Closed End, Solder/Quick Connect Terminals 5 = Plain Enclosure with Bottom Mounted 6-32 Stud, Solder/Quick Connect Terminals 6 = Plain Enclosure with Bottom Mounted Bracket, Solder/Quick Connect Terminals 7 = Open, Printed Circuit Board Terminals 8 = Plain Enclosure, Printed Circuit Board Terminals 0 = Special						
3. Contact Arrangement: 2 = 2 Form C (DPDT) 6 = 2 Form A (DPST-NO) 7 = 2 Form B (DPST-NC) 0 = Special 8 = 1 Form X (SPST-NO-DM) 9 = 1 Form Y (SPST-NC-DB)						
4. Coil: A = 6VDC C = 24VDC F = 110VDC N = 6VAC Q = 24VAC U = 240VAC S = Special B = 12VDC D = 48VDC P = 12VAC T = 120VAC M = 208VAC						
5. Contacts: 2 = 1/4" (6.25mm) Diameter, Silver-Cadmium Oxide. 0 = Special 5 = 3/16" (4.75mm) Diameter, Pure Fine Silver. 6 = 1/4" (6.25mm) Diameter, Silver-Cadmium Oxide (Requires Contact Arrangement 6 [2 form A] or 7 [2 form B] in step 3 above).						
6. Standard or Special: 00 = Standard F0 = Class "F" Coil A1-Z9 = Special Construction or Feature L0 = Lamp in parallel with coil M0 = Magnetic blowout						

NOTE: No sockets are available for this relay.

Our authorized distributors are more likely to maintain the following items in stock for immediate delivery.

- | | | | |
|------------|------------|------------|------------|
| 187-32B200 | 187-32D200 | 187-32Q200 | 187-32U200 |
| 187-32C200 | 187-32F200 | 187-32T200 | |

Outline Dimensions

Open 187-1

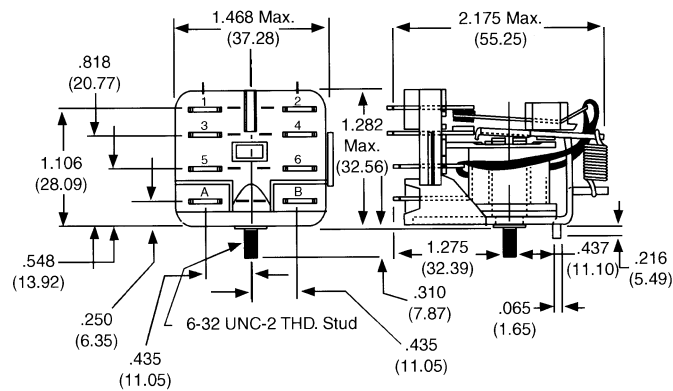

Dust Cover 187-2

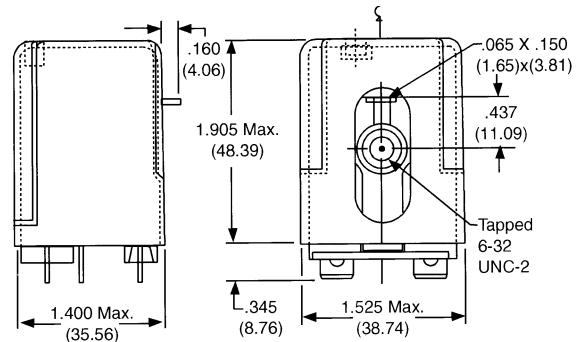

Dust Cover with Mounting Flange 187-3

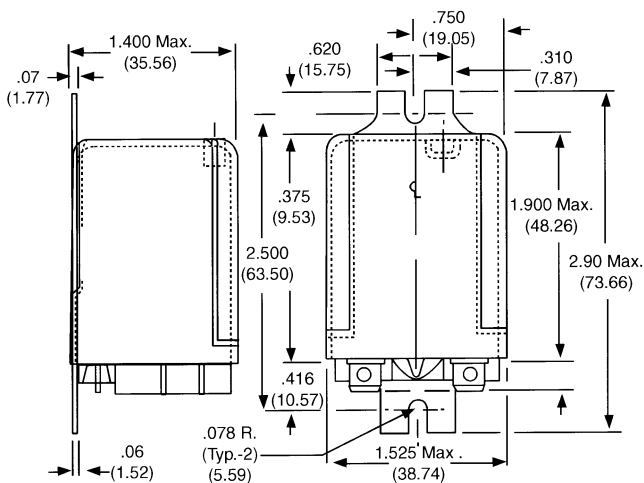

Dust Cover with Bracket and Stud on End 187-4

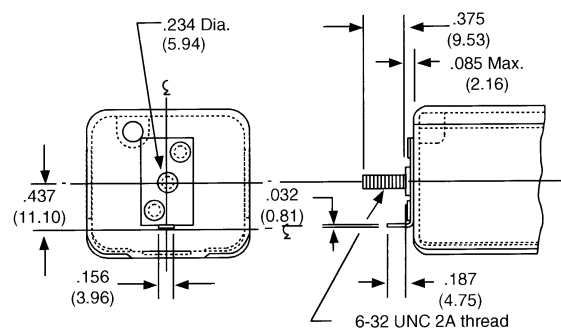

Outline Dimensions (Continued)

Bottom Stud 187-5

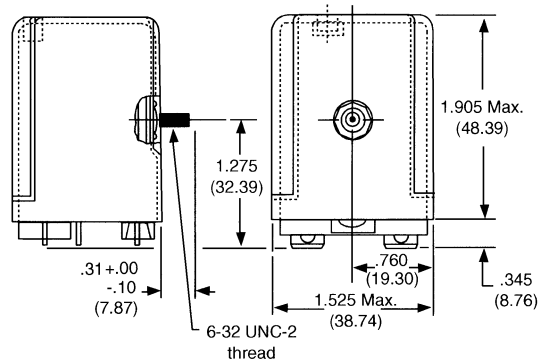

Bracket Mount 187-6

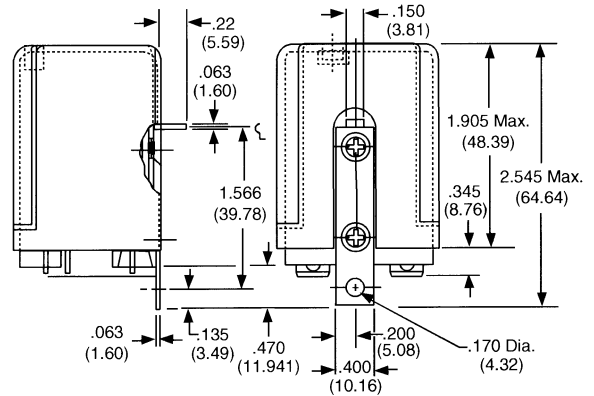

Terminal Dimensions

.250" (6.35mm) Quick Connect

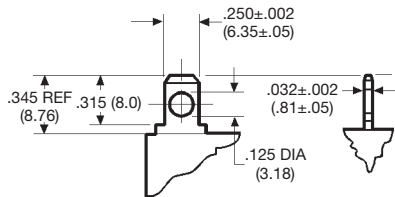

Printed Circuit

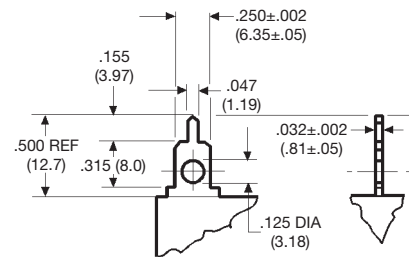

Wiring Diagrams

2 Form C (DPDT)

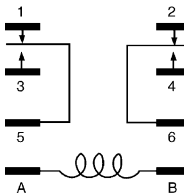

2 Form A (DPST-NO)

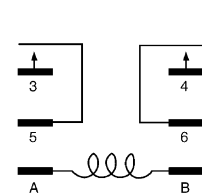

2 Form B (DPST-NC)

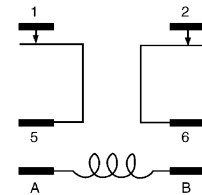

1 Form X (SPST-NO-DM)

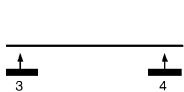

1 Form Y (SPST-NC-DB)

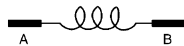
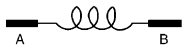
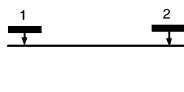

PC Board Layout (Bottom View)

Suggested PCB layout for 187 series relays with PCB terminals

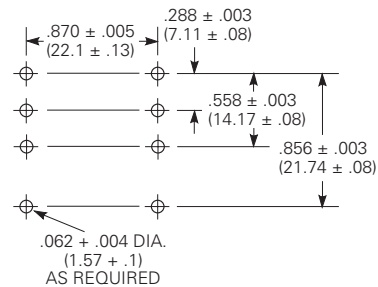

Reference Only

Disclaimer

While Tyco Electronics has made every reasonable effort to ensure the accuracy of the information in this document, Tyco Electronics does not guarantee that it is error-free, nor does Tyco Electronics make any other representation, warranty or guarantee that the information is accurate, correct, reliable or current.

Tyco Electronics reserves the right to make any adjustments to the information contained herein at any time without notice. Tyco Electronics expressly disclaims all implied warranties regarding the information contained herein, including, but not limited to, any implied warranties of merchantability or fitness for a particular purpose.

The dimensions in this catalog are for reference purposes only and are subject to change without notice. Specifications are subject to change without notice. Consult Tyco Electronics for the latest dimensions and design specifications.

Данный компонент на территории Российской Федерации

Вы можете приобрести в компании MosChip.

Для оперативного оформления запроса Вам необходимо перейти по данной ссылке:

<http://moschip.ru/get-element>

Вы можете разместить у нас заказ для любого Вашего проекта, будь то серийное производство или разработка единичного прибора.

В нашем ассортименте представлены ведущие мировые производители активных и пассивных электронных компонентов.

Нашей специализацией является поставка электронной компонентной базы двойного назначения, продукции таких производителей как XILINX, Intel (ex.ALTERA), Vicor, Microchip, Texas Instruments, Analog Devices, Mini-Circuits, Amphenol, Glenair.

Сотрудничество с глобальными дистрибьюторами электронных компонентов, предоставляет возможность заказывать и получать с международных складов практически любой перечень компонентов в оптимальные для Вас сроки.

На всех этапах разработки и производства наши партнеры могут получить квалифицированную поддержку опытных инженеров.

Система менеджмента качества компании отвечает требованиям в соответствии с ГОСТ Р ИСО 9001, ГОСТ РВ 0015-002 и ЭС РД 009

Офис по работе с юридическими лицами:

105318, г.Москва, ул.Щербаковская д.3, офис 1107, 1118, ДЦ «Щербаковский»

Телефон: +7 495 668-12-70 (многоканальный)

Факс: +7 495 668-12-70 (доб.304)

E-mail: info@moschip.ru

Skype отдела продаж:

moschip.ru

moschip.ru_4

moschip.ru_6

moschip.ru_9