

# CliQ M DIN Rail Power Supply

## 24V 960W 1 Phase / DRM-24V960W1PN



### Highlights & Features

- Universal AC input voltage range
- Built-in active PFC with up to 95.5% efficiency
- Full power from -25°C to +60°C @ 5,000m (16,400 ft.)
- Power Boost of 150% up to 7 seconds
- Advanced Power Boost (APB) – protect system and ensure continuing operation when large inrush current detected due to faulty load on a multiple load connection
- DNV GL and ABS approvals for maritime applications
- Built-in DC OK Contact and LED indicator for DC OK/ Overload
- Features current sharing for parallel connection / Shut-Down Input / Remote Control of Output Voltage / Internal Data Logging for troubleshooting
- Conformal coating on PCBAs to protect against common dust and chemical pollutants

### Safety Standards



CB Certified for worldwide use

**Model Number:** DRM-24V960W1PN  
**Unit Weight:** 2.87 kg (6.33 lb)  
**Dimensions (L x W x D):** 124 x 125 x 133.6 mm (4.88 x 4.92 x 5.26 inch)

### General Description

Delta Electronics is introducing one of the slimmest DIN rail industrial power supplies in its class, the CliQ M DIN rail power supply series. To fulfill the demands in maritime applications, the product is designed according to major industrial and maritime (Lloyd's Register) safety standards. Other features include compliance with harmonic current IEC/EN 61000-3-2, class A, built-in DC OK contacts, and an LED for indicating DC OK and Overload conditions. In addition to having Power Boost of 150% up to 7 seconds, the CliQ M series is the first in the CliQ family to feature Advanced Power Boost (APB). With multiple loads connected in a system, a large inrush current could be drawn (demanded) due to one fault load. This will be detected by APB. The APB will trip the circuit breaker (circuit breaker with appropriate rating based on the system load) on the current path of the fault load due to high current. This thus prevents the system from shutting down while the other connected current paths continue to operate without interruption.

### Model Information

CliQ M DIN Rail Power Supply

| Model Number   | Input Voltage Range | Rated Output Voltage | Rated Output Current |
|----------------|---------------------|----------------------|----------------------|
| DRM-24V960W1PN | 85-264Vac           | 24Vdc                | 40.0A                |

### Model Numbering

| DR       | M –           | 24V            | 960W         | 1            | P                          | N   |
|----------|---------------|----------------|--------------|--------------|----------------------------|---|
| DIN Rail | CliQ M Series | Output Voltage | Output Power | Single Phase | Advanced Power Boost (APB) | N - Metal Case, without Class I, Div 2 and ATEX approvals |



# CliQ M DIN Rail Power Supply

## 24V 960W 1 Phase / DRM-24V960W1PN

### Specifications

#### Input Ratings / Characteristics

|  |      |   |   |        |  |
|--|------|---|---|--------|--|
| Nominal Input Voltage                  |      | 100-240Vac  | Applicable for TN-, TT and IT mains networks      |        |  |
| Input Voltage Range                    |      | 90-264Vac   | Continuously operating                            |        |  |
|  |      | 85-90Vac  | With power de-rating. Refer to Fig. 5 on page 10. |        |  |
| Input Frequency                        | Nom. | 50-60Hz   | Range: 47-63Hz                                    |        |  |
| DC Input Voltage Range                 |      | N/A   | Not applicable for DC input                       |        |  |
|  |      | 100Vac  | 120Vac  | 230Vac |  |
| Input Current                          | Typ. | 10.50A  | 8.60A   | 4.50A  | At 24V, 40A. Refer to Fig. 1 on page 3.  |
|  | Max. | 12.00A  | 10.10A  | 6.00A  | At 24V, 40A.   |
| Efficiency                             | Typ. | 94.10%  | 94.71%  | 95.98% | At 24V, 40A. Refer to Fig. 2 on page 3.  |
|  | Min. | 93.20%  | 93.60%  | 94.60% | At 24V, 40A.   |
| Average Efficiency                     | Typ. | 93.23%  | 93.60%  | 94.49% | At 24V, 10.0A (25%), 20.0A (50%),  |
|  | Min. | 92.70%  | 93.00%  | 93.60% | 30.0A (75%), 40.0A (100%)  |
| Max Power Dissipation                  | Typ. | 4.20W   | 3.03W   | 2.60W  | Shut-Down function activated   |
|  | Max. | 4.50W   | 4.50W   | 4.50W  | Shut-Down function activated   |
|  | Typ. | 5.58W   | 4.61W   | 3.70W  | At 24V, 0A. Refer to Fig. 3 on page 3.   |
|  | Max. | 13.9W   | 13.1W   | 13.2W  | At 24V, 0A.  |
|  | Typ. | 60.32W  | 53.71W  | 40.21W | At 24V, 40A. Refer to Fig. 3 on page 3.  |
|  | Max. | 70.00W  | 65.60W  | 54.80W | At 24V, 40A.   |
| Max Inrush Current (Cold Start)        | Typ. | 8A  | 10A   | 17A    | Entire operating temperature range   |
|  | Max. | 11A   | 13A   | 20A    |  |
| Max Inrush Energy (Cold Start)         | Max. | 5A <sup>2</sup> s                                     |   |        |  |
| Power Factor                           | Typ. | 0.99  | 0.99  | 0.96   | At 24V, 40A. Refer to Fig. 4 on page 3.  |
|  | Min. | 0.97  | 0.97  | 0.95   | At 24V, 40A.   |
| Crest Factor                           | Max. | 1.72  | 1.78  | 1.81   | At 24V, 40A.   |
| Leakage Current (Enclosure to Neutral) |      | 0.50mA / 1.21mA<br>0.71mA / 1.73mA<br>1.18mA / 2.82mA |   |        | 110Vac, 50Hz, TN/TT system / IT system<br>132Vac, 60Hz, TN/TT system / IT system<br>264Vac, 50Hz, TN/TT system / IT system |

# CliQ M DIN Rail Power Supply

## 24V 960W 1 Phase / DRM-24V960W1PN

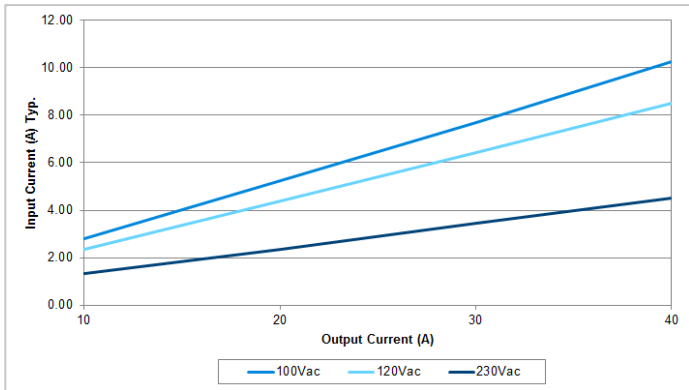

Fig. 1 Input Current VS Output Load at 24V

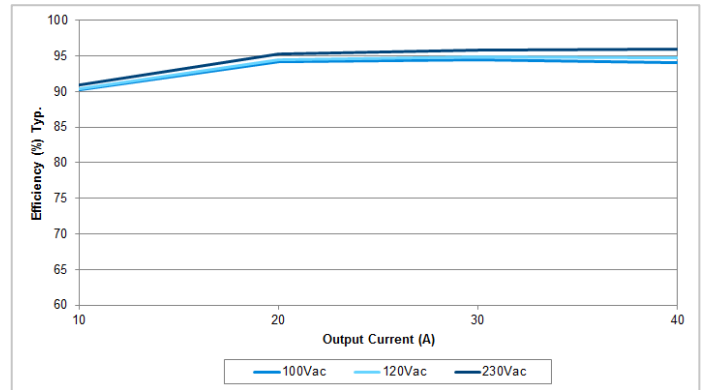

Fig. 2 Efficiency VS Output Load at 24V

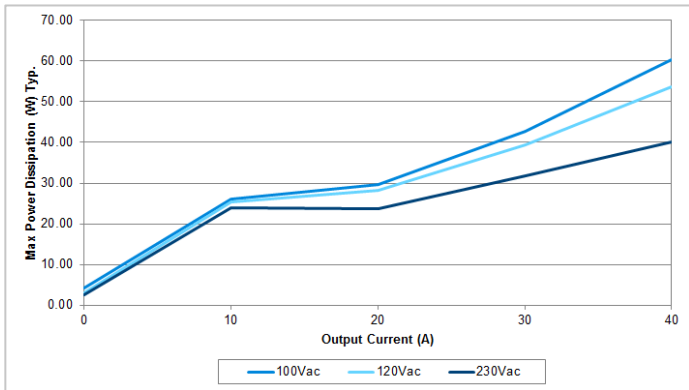

Fig. 3 Max Power Dissipation VS Output Load at 24V

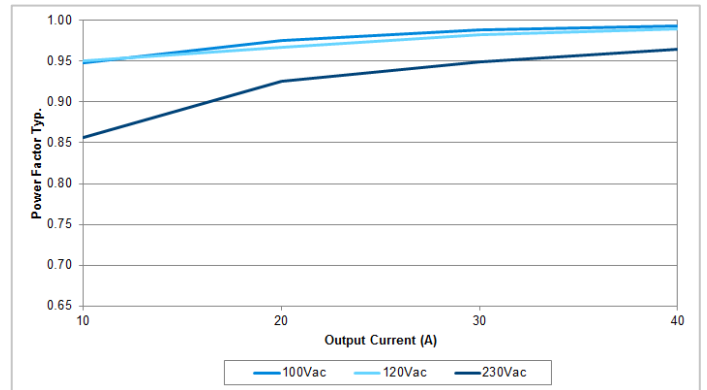

Fig. 4 Power Factor VS Output Load at 24V

# CliQ M DIN Rail Power Supply

## 24V 960W 1 Phase / DRM-24V960W1PN

### Output Ratings / Characteristics\*

|   |                              |   |  |
|---|------------------------------|---|--|
| Nominal Output Voltage                            |                              | 24Vdc   |  |
| Factory Set Point Tolerance                       |                              | 24Vdc $\pm$ 1.0%  |  |
| Output Voltage Adjustment Range                   |                              | 24-28Vdc  |  |
| Output Current                                    | Nom.<br>Nom.                 | 40.0A / 34.3A<br>60.0A / 51.5A<br>(Slew rate 0.1A/ $\mu$ s)   | Continuously operating at 24V / 28V Power Boost for 5 seconds at 24V / 28V, refer to the details in the Function section               |
| Output Power                                      | Nom.<br>Nom.                 | 960W / 960.4W<br>1,440W / 1,442W  | Continuously operating at 24V / 28V Power Boost for 5 seconds at 24V / 28V, refer to the details in the Functions section              |
| Power Boost Duration                              | Typ.<br>Max.                 | 5 seconds<br>7 seconds  | Duration after which output voltage start to droop. Refer to the details in the Function section at Overload & Overcurrent Protections |
| Power Boost Recovery Time                         | Typ.                         | 17 seconds  | Required wait duration before next Power Boost can be delivered by the power supply. Refer to the details in the Function section      |
| Advanced Power Boost<br>(Slew rate 0.1A/ $\mu$ s) | Typ.<br>Typ.<br>Typ.<br>Typ. | 80A @ 50ms, resistive load<br>110A @ 25ms, resistive load<br>200A @ 2ms, resistive load<br>200A @ 5ms, resistive load | Output voltage will drop (Refer to the details in the Function section)  |
| Line Regulation                                   | Max.                         | 10mV (@ 85-264Vac input, 100% load)   |  |
| Load Regulation                                   | Max.<br>Typ.                 | 50mV (@ single mode, 0-100% load)<br>1000mV (@ parallel mode, 0-100% load)  |  |
| PARD**  | Max.                         | 100mVpp   | 20Hz to 20MHz, 50Ohm, warm up for 10mins   |

\*For power de-rating from 60°C to 70°C, see power de-rating on page 10.

\*\*PARD is measured with an AC coupling mode, 5cm wires, and in parallel with 0.1 $\mu$ F ceramic capacitor & 47 $\mu$ F electrolytic capacitor.

|  |                     | 100Vac   | 120Vac | 230Vac |   |
|--|---------------------|--|--------|--------|---|
| Rise Time  | Max.                |  | 75ms   |        | 0 $\mu$ F, 24V, 40A.  |
|  | Max.                |  | 75ms   |        | 40,000 $\mu$ F, 24V, 40A.                                       |
| Start-up Time  | Max.                |  | 800ms  |        | At 24V, 40A.  |
| Hold-up Time   | Typ.                |  | 52ms   |        | At 24V, 20A.  |
|  | Min.                |  | 45ms   |        | At 24V, 20A.  |
|  | Typ.                |  | 24ms   |        | At 24V, 40A.  |
|  | Min.                |  | 23ms   |        | At 24V, 40A.  |
| Dynamic Response<br>(Overshoot & Undershoot O/P Voltage) | Max.                | $\pm$ 5% @ 0.7-40A load  |        |        | Slew rate 0.1A/ $\mu$ s<br>(@ 5Hz, 50Hz & 1kHz, 50% Duty Cycle) |
| Start-up with Capacitive Loads                           | Max.                | 40,000 $\mu$ F   |        |        |   |
| Output Capacitance                                       | Typ.                | 10,200 $\mu$ F   |        |        | Built-in output capacitors                                      |
| Functional   | DC OK Relay Contact | Rated: 30V at 1A, resistive load. Refer to the details in the Function section at DC OK Relay Contacts and LED Indicator Characteristics on page 13. |        |        |   |
|  | Parallel operation  | Yes, refer to Parallel Operation on page 19.   |        |        |   |

# CliQ M DIN Rail Power Supply

## 24V 960W 1 Phase / DRM-24V960W1PN

### Mechanical

|                                   |  |                         |
|-----------------------------------|--|-------------------------|
| Case Cover / Chassis              | Aluminium  |                         |
| Dimensions (L x W x D)            | 124 x 125 x 133.6 mm (4.88 x 4.92 x 5.26 inch)     |                         |
| Unit Weight                       | 2.87 kg (6.33 lb)                                  |                         |
| Indicator                         | Green LED (DC OK) and Red LED (Overload)           |                         |
| Cooling System                    | Convection   |                         |
| Terminal                          | Input  | 3 Pins (Rated 600V/35A) |
|                                   | Output   | 4 Pins (Rated 300V/65A) |
|                                   | Signal   | 5 Pins (Rated 300V/10A) |
| Wire                              | Input  | AWG 16-8                |
|                                   | Output   | AWG 10-6                |
|                                   | Signal   | AWG 20-16               |
| Mounting Rail                     | Standard TS35 DIN Rail in accordance with EN 60715 |                         |
| Noise (1 Meter from power supply) | Sound Pressure Level (SPL) < 25dBA                 |                         |

### Environment

|                             |  |  |
|-----------------------------|--|--|
| Surrounding Air Temperature | Operating  | -25°C to +70°C (Cold start -40°C)  |
|                             | Storage  | -40°C to +85°C   |
| Power De-rating             | Vertical Mounting  | <b>Temperature:</b><br>> 60°C de-rate power by 2.5% / °C<br><b>Input Voltage:</b><br>If < 90Vac, > 55°C de-rate power by 1.67% / °C  |
|                             | Horizontal Mounting  | <b>Temperature:</b><br>> 40°C de-rate power by 1.67% / °C<br><b>Input Voltage:</b><br>If < 90Vac, > 35°C de-rate power by 1.43% / °C |
| Operating Humidity          | 5 to 95% RH (Non-Condensing)   |  |
| Operating Altitude          | 0 to 5,000 Meters (16,400 ft.)<br>0 to 2,500 Meters (8,200 ft.) for IEC/EN 61558 |  |
| Shock Test                  | Non-Operating  | IEC 60068-2-27, Half Sine Wave: 30G for a duration of 18ms;<br>3 times per direction, 6 times in total                               |
| Vibration                   | Non-Operating  | IEC 60068-2-6, Sine Wave: 10-500Hz; 3G peak; displacement of 0.35mm; 60 min per axis for all X, Y, Z directions                      |
| Bump Test                   | Operating  | IEC 60068-2-29, Half Sine Wave: 10G for a duration of 11ms,<br>1,000 times per direction, 6,000 times in total                       |
| Over Voltage Category       | III  | According to IEC/EN 62477-1 / EN 60204-1 (clearance and creepage distances) and IEC 62103 (safety part)                              |
| Pollution Degree            | 2  |  |

# CliQ M DIN Rail Power Supply

## 24V 960W 1 Phase / DRM-24V960W1PN

### Protections

|                                    |  |  |
|------------------------------------|--|--|
| Overvoltage                        | < 32V, SELV Output, Hiccup Mode, Non-Latching (Auto-Recovery)                | Refer to the details in the Function section                           |
| Overload / Overcurrent             | > 150% of rated load current, Constant current, Hiccup Mode (Auto-Recovery)  | Refer to the details in the Function section                           |
| Over Temperature                   | < 80°C Surrounding Air Temperature @ 100% load, Non-Latching (Auto-Recovery) | Refer to the details in the Function section                           |
| Short Circuit                      | Hiccup Mode, Non-Latching (Auto-Recovery when the fault is removed)          | Load impedance ≤ 100mOhm, refer to the details in the Function section |
| Transient Surge Voltage Protection | MOV (Metal Oxide Varistor)   |  |
| Internal Fuse at L pin             | T20A   |  |
| Degree of Protection               | IP20   |  |
| Protection Against Shock           | Class I with PE* connection  |  |

\*PE: Primary Earth

### Reliability Data

| MTBF (as per Telcordia SR-332) | 513,800 hrs.   | I/P: 100Vac, O/P: 24V, 40A, Ta: 25°C |        |        |             |  |             |  |            |            |             |             |                         |
|--------------------------------|--|--------------------------------------|--------|--------|-------------|--|-------------|--|------------|------------|-------------|-------------|-------------------------|
|                                | 312,900 hrs.   | I/P: 100Vac, O/P: 24V, 40A, Ta: 40°C |        |        |             |  |             |  |            |            |             |             |                         |
| Expected Cap Life Time**       | <table border="1"> <thead> <tr> <th>100Vac</th> <th>230Vac</th> </tr> </thead> <tbody> <tr> <td colspan="2">131,400hrs.</td> </tr> <tr> <td colspan="2">131,400hrs.</td> </tr> <tr> <td>60,000hrs.</td> <td>92,000hrs.</td> </tr> <tr> <td>131,400hrs.</td> <td>115,400hrs.</td> </tr> </tbody> </table> |                                      | 100Vac | 230Vac | 131,400hrs. |  | 131,400hrs. |  | 60,000hrs. | 92,000hrs. | 131,400hrs. | 115,400hrs. | O/P: 24V, 40A, Ta: 25°C |
|                                | 100Vac   | 230Vac                               |        |        |             |  |             |  |            |            |             |             |                         |
|                                | 131,400hrs.  |                                      |        |        |             |  |             |  |            |            |             |             |                         |
|                                | 131,400hrs.  |                                      |        |        |             |  |             |  |            |            |             |             |                         |
|                                | 60,000hrs.   | 92,000hrs.                           |        |        |             |  |             |  |            |            |             |             |                         |
| 131,400hrs.                    | 115,400hrs.  |                                      |        |        |             |  |             |  |            |            |             |             |                         |
|                                |  | O/P: 24V, 20A, Ta: 25°C              |        |        |             |  |             |  |            |            |             |             |                         |
|                                |  | O/P: 24V, 40A, Ta: 40°C              |        |        |             |  |             |  |            |            |             |             |                         |
|                                |  | O/P: 24V, 20A, Ta: 40°C              |        |        |             |  |             |  |            |            |             |             |                         |

\*\*Estimated lifetime when 24 hours operating a day and E-cap's manufacturer guarantee at 131,400 hrs. (15 years) as maximum limit of lifetime.

# CliQ M DIN Rail Power Supply

## 24V 960W 1 Phase / DRM-24V960W1PN

### Safety Standards / Directives

|  |                   |   |
|--|-------------------|---|
| Electrical Equipment of Machines                               |                   | EN 60204-1 (over voltage category III)  |
| Electrical Equipment for Use in Electrical Power Installations |                   | IEC/EN 62477-1 / IEC 62103  |
| Safety Entry Low Voltage                                       |                   | PELV* (EN 60204-1), SELV (EN 60950-1)   |
| Electrical Safety  | SIQ Bauart        | EN 60950-1, EN 61558-1, EN 61558-2-16, EN 61010-1, EN 61010-2-201                 |
|  | UL/cUL recognized | UL 60950-1 and CSA C22.2 No. 60950-1 (File No. E191395)                           |
|  | CB scheme         | IEC 60950-1, IEC 61558-1, IEC 61558-2-16, IEC 61010-1, IEC 61010-2-201            |
| Industrial Control Equipment                                   | UL/cUL listed     | UL 508 and CSA C22.2 No. 107.1-01 (File No. E315355)                              |
|  | CSA               | CSA C22.2 No. 107.1-01 (File No. 181564)  |
| Maritime   | DNV GL            | Germanischer Lloyd classified   |
|  | ABS               | American Bureau for Shipping) PDA<br>Environmental category: C, EMC2              |
| CE   |                   | In conformance with EMC Directive 2014/30/EU and Low Voltage Directive 2014/35/EU |
| Material and Parts   |                   | RoHS Directive 2011/65/EU Compliant (EN 50581)                                    |
| Galvanic Isolation   | 4.54KVac          | Input / Output  |
|  | 2.5KVac           | Input / PE  |
|  | 4.54KVac          | Input / DC OK relay contact**   |
|  | 1.5KVac           | Output / PE   |
|  | 0.5KVac           | Output / DC OK relay contact  |
|  | 1.5KVac           | DC OK relay contact / PE  |
| Isolation Resistance   | > 5M $\Omega$ m   | Input to Output, 500Vdc   |
| PE Resistance  | < 0.1 $\Omega$ m  |   |

\*Output must be earthed in the final unit in order to comply with PELV requirements according to standard EN 60204-1.

\*\*Recommend to connect DC OK pins together with output pins.

# CliQ M DIN Rail Power Supply

## 24V 960W 1 Phase / DRM-24V960W1PN

### EMC

|   |   |  |   |  |
|---|---|--|---|--|
| Emissions (CE & RE)                     |   | Generic Standards: EN 61000-6-3<br>CISPR 32, EN 55032, CISPR 11, EN 55011, FCC Title 47: Class B   |   |  |
| Component Power Supply for General Use  |   | EN 61204-3   |   |  |
| Immunity                                |   | Generic Standards: EN 55024, EN 61000-6-2  |   |  |
| Electrostatic Discharge                 | IEC 61000-4-2                                   | Level 4 Criteria A <sup>1)</sup><br>Air Discharge: 15kV<br>Contact Discharge: 8kV  |   |  |
| Radiated Field                          | IEC 61000-4-3                                   | Level 3 Criteria A <sup>1)</sup><br>80MHz-1GHz, 20V/M, 80% modulation (1kHz)<br>1.4GHz-2GHz, 20V/M, 80% modulation (1KHz)<br>2GHz-2.7GHz, 20V/M, 80% modulation (1KHz) |   |  |
| Electrical Fast Transient / Burst       | IEC 61000-4-4                                   | Level 4 Criteria A <sup>1)</sup><br>4kV  |   |  |
| Surge                                   | IEC 61000-4-5                                   | Level 4 Criteria A <sup>1)</sup><br>Common Mode <sup>3)</sup> : 4kV<br>Differential Mode <sup>4)</sup> : 2kV   |   |  |
| Conducted                               | IEC 61000-4-6                                   | Level 3 Criteria A <sup>1)</sup><br>150kHz-80MHz, 20Vrms   |   |  |
| Power Frequency Magnetic Fields         | IEC 61000-4-8                                   | Criteria A <sup>1)</sup><br>30A/Meter  |   |  |
| Voltage Dips and Interruptions          | IEC 61000-4-11                                  | 0% of 100Vac<br>40% of 100Vac<br>70% of 100Vac<br>0% of 100Vac<br>0% of 240Vac<br>40% of 240Vac<br>70% of 240Vac<br>0% of 240Vac                                       | 0Vac, 20ms<br>40Vac, 200ms<br>70Vac, 500ms<br>0Vac, 5000ms<br>0Vac, 20ms<br>96Vac, 200ms<br>168Vac, 500ms<br>0Vac, 5000ms | Criteria A <sup>1)</sup><br>Criteria B <sup>2)</sup><br>Criteria A <sup>1)</sup><br>Criteria B <sup>2)</sup><br>Criteria A <sup>1)</sup><br>Criteria A <sup>1)</sup><br>Criteria A <sup>1)</sup><br>Criteria B <sup>2)</sup> |
| Low Energy Pulse Test (Ring Wave)       | IEC 61000-4-12                                  | Level 3 Criteria A <sup>1)</sup><br>Common Mode <sup>3)</sup> : 2kV<br>Differential Mode <sup>4)</sup> : 1kV   |   |  |
| Harmonic Current Emission               | IEC/EN 61000-3-2, Class A                       |  |   |  |
| Voltage Fluctuation and Flicker         | IEC/EN 61000-3-3                                |  |   |  |
| Voltage Sag Immunity<br>SEMI F47 – 0706 | 80% of 120Vac<br>70% of 120Vac<br>50% of 120Vac | 96Vac, 1000ms<br>84Vac, 500ms<br>60Vac, 200ms  | Criteria A <sup>1)</sup><br>Criteria A <sup>1)</sup><br>Criteria A <sup>1)</sup>  |  |

1) Criteria A: Normal performance within the specification limits  
 2) Criteria B: Temporary degradation or loss of function which is self-recoverable  
 3) Asymmetrical: Common mode (Line to earth)  
 4) Symmetrical: Differential mode (Line to line)





# CliQ M DIN Rail Power Supply

## 24V 960W 1 Phase / DRM-24V960W1PN

### Block Diagram

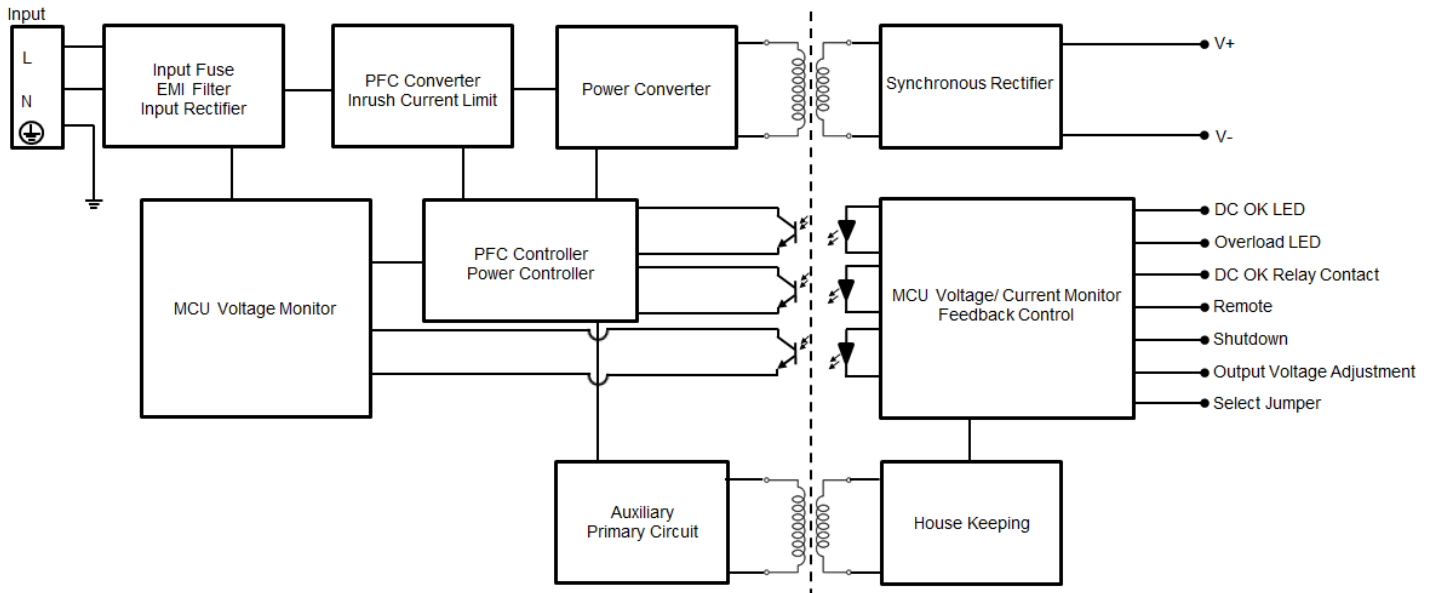

### Device Description

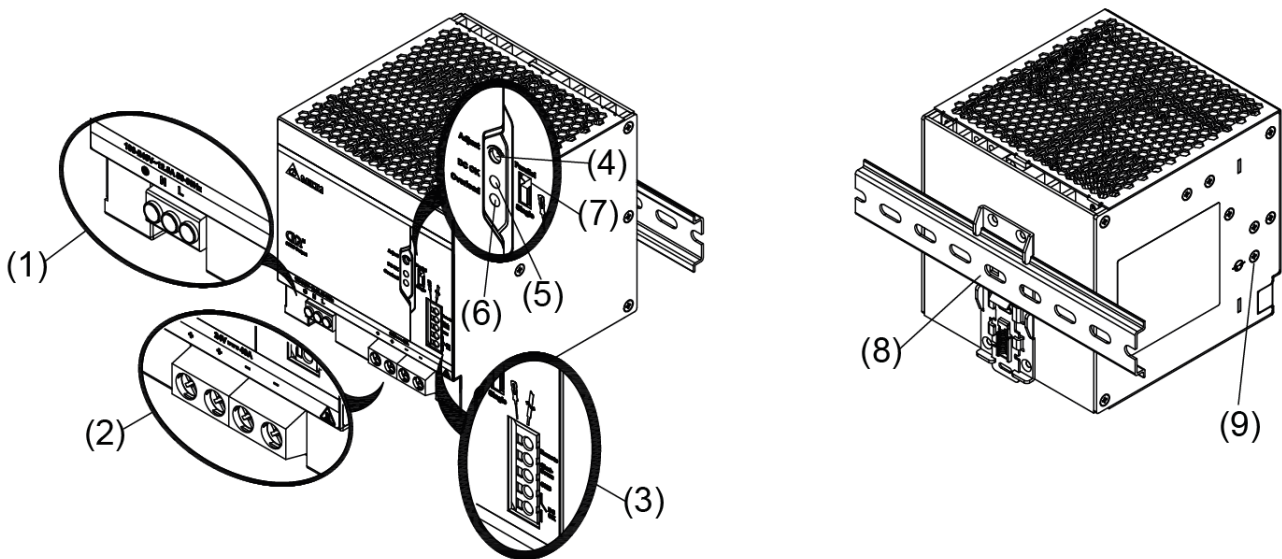

- 1) Input terminal block connector
- 2) Output terminal block connector
- 3) Signal terminal block connector
- 4) DC voltage adjustment potentiometer
- 5) DC OK LED (Green)
- 6) Overload LED (Red)
- 7) Select jumper (Single/Parallel operation mode)
- 8) Universal mounting rail system
- 9) Gas discharge tube (on left side of housing) used for surge protection.  
Disconnect gas discharge tube (remove Philips head screw) during dielectric test of > 0.5KVac or 0.8KVdc.

# CliQ M DIN Rail Power Supply

## 24V 960W 1 Phase / DRM-24V960W1PN

### Dimensions

L x W x D: 124 x 125 x 133.6 mm (4.88 x 4.92 x 5.26 inch)

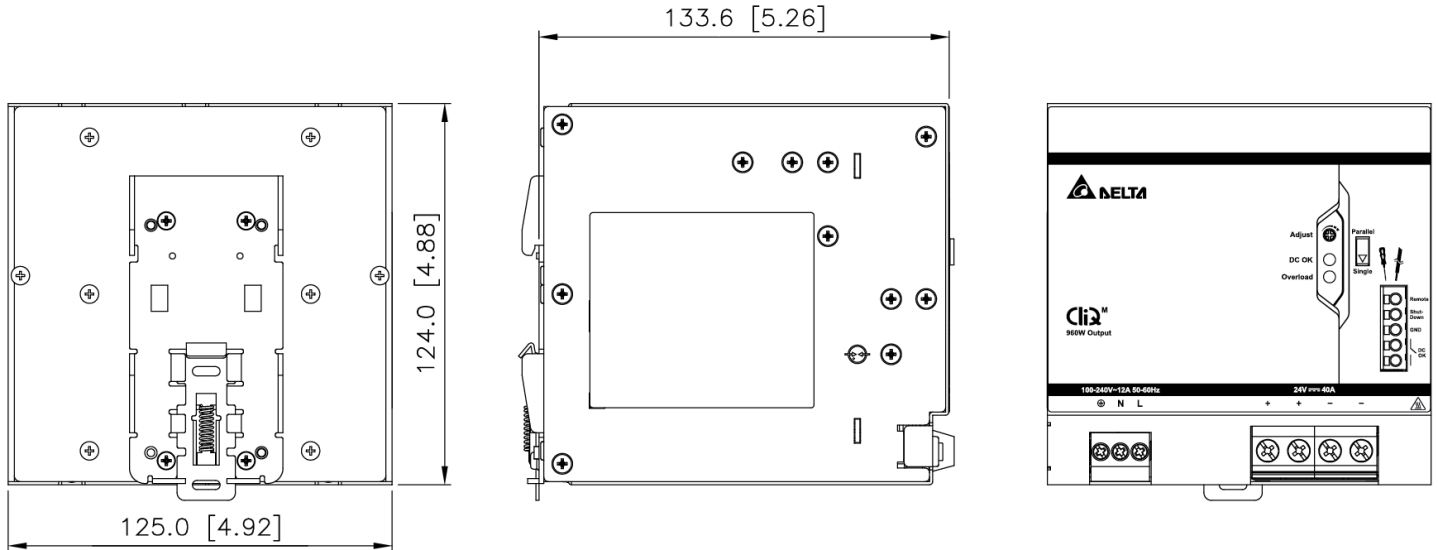

### Engineering Data

#### Output Load De-rating VS Surrounding Air Temperature

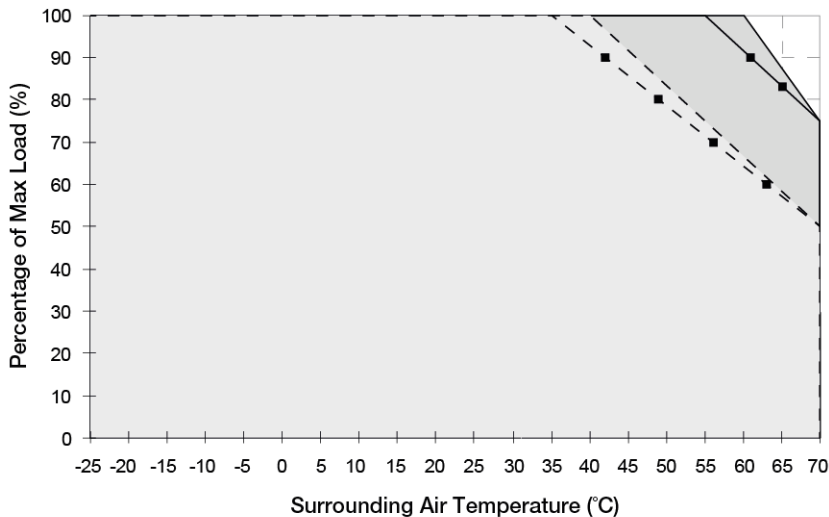

| V <sub>in</sub> | Vertical Mounting | Horizontal Mounting |
|-----------------|-------------------|---------------------|
| 90-264Vac       | —                 | - - -               |
| < 90Vac         | —◆—               | - ◆ -               |

#### Note

1. Power supply components may degrade, or be damaged, when the power supply is continuously used outside the shaded region, refer to the graph shown in Fig. 5.
2. If the output capacity is not reduced when the surrounding air temperature exceeds its specification as defined on Page 5 under "Environment", the device will run into Over Temperature Protection. When activated, the output voltage will go into bouncing mode and will recover when the surrounding air temperature is lowered or the load is reduced as far as necessary to keep the device in working condition.
3. In order for the device to function in the manner intended, it is also necessary to keep a safety distance as recommended in the safety instructions while the device is in operation.
4. Depending on the surrounding air temperature and output load delivered by the power supply, the device can be very hot!
5. If the device has to be mounted in any other orientation, please contact [info@deltapsu.com](mailto:info@deltapsu.com) for more details.

**Fig. 5 De-rating for Vertical Mounting Orientation**  
 > 60°C de-rate power by 2.5% / °C  
 If V<sub>in</sub> < 90Vac, > 55°C de-rate power by 1.67% / °C

**De-rating for Horizontal Mounting Orientation**  
 > 40°C de-rate power by 1.67% / °C  
 If V<sub>in</sub> < 90Vac, > 35°C de-rate power by 1.43% / °C

# CliQ M DIN Rail Power Supply

## 24V 960W 1 Phase / DRM-24V960W1PN

### Output Load De-rating VS Input Voltage

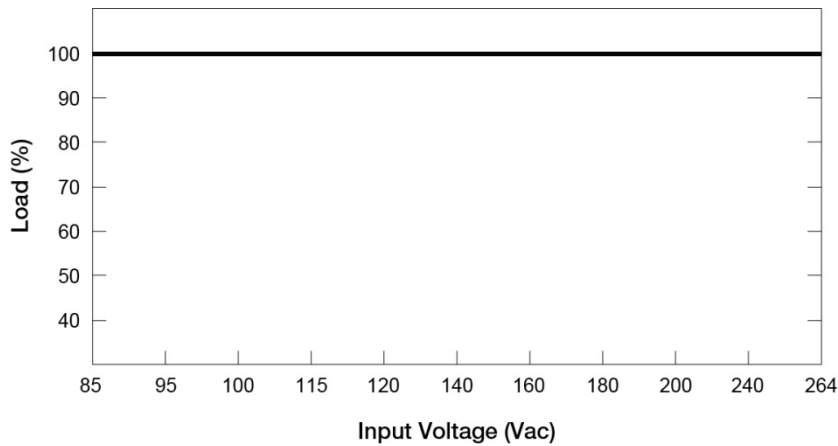

■ No output power de-rating for the input voltage range, refer to Fig. 5 on page 10

### Assembly & Installation

The power supply unit (PSU) can be mounted on 35mm DIN rails in accordance with EN 60715. For Vertical Mounting, the device should be installed with input terminal block at the bottom. For Horizontal Mounting, the device should be installed with input terminal block on the left side.

Each device is delivered ready to install.

1. Tilt the unit upwards and insert it onto the DIN rail. Snap on the DIN rail as shown in Fig. 6.1.
2. Push downwards until stopped.
3. Press against the bottom front side for locking.
4. Shake the unit slightly to ensure that it is secured.
5. To uninstall, pull or slide down the latch with screw driver as shown in Fig. 6.2. Then slide the power supply unit (PSU) in the opposite direction, release the latch and pull out the power supply unit (PSU) from the rail.

#### Mounting

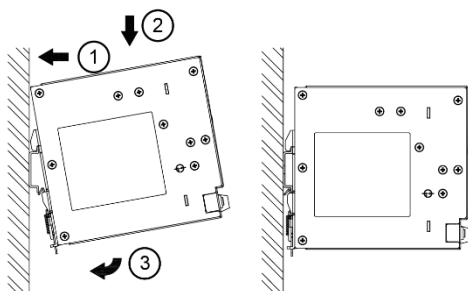

Fig. 6.1 Mounting

#### Dismounting

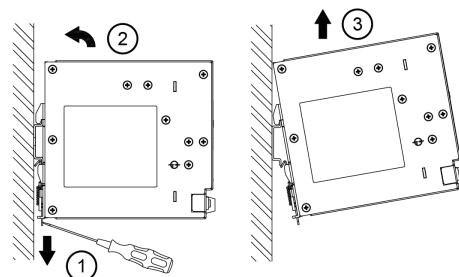

Fig. 6.2 Dismounting

In accordance to EN 60950 / UL 60950, flexible cables require ferrules. Use appropriate copper cables designed to sustain operating temperature of:

1. 60°C, 60°C / 75°C for USA
2. At least 90°C for Canada
3. At least 105°C for IEC/EN61010-1, IEC/EN61010-2-201.

# CliQ M DIN Rail Power Supply

## 24V 960W 1 Phase / DRM-24V960W1PN

### Safety Instructions

#### ■ Vertical Mounting

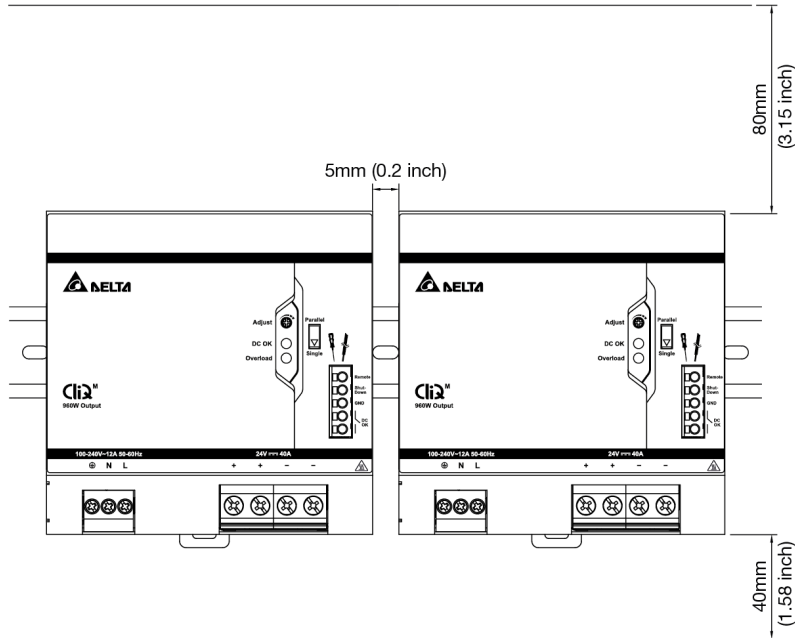

#### ■ Horizontal Mounting

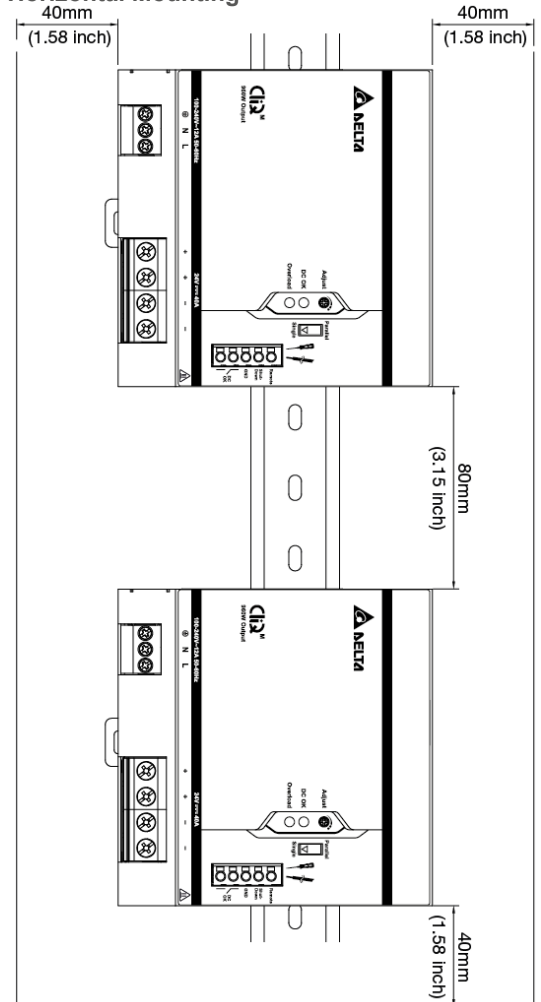

- ALWAYS switch mains of input power OFF before connecting and disconnecting the input voltage to the device. If mains are not turned OFF, there is risk of explosion / severe damage.
- If the unit is used in a manner not specified by the manufacturer, the protection provided by the equipment may be impaired.
- To guarantee sufficient convection cooling, please refer to the following instructions to ensure sufficient clearance around the device.

**Vertical Mounting:** 80mm (3.15 inch) above and 40mm (1.58 inch) below the device as well as a lateral distance of 5mm (0.2 inch) to other units. In case the adjacent device is a heat source, the lateral distance will be 15mm (0.6 inch).

**Horizontal Mounting:** 80mm (3.15 inch) above and 40mm (1.58 inch) below the device as well as a lateral distance of 40mm (1.58 inch) to other units.

- The external enclosure where the unit will be installed shall meet the requirements for mechanical, electrical and fire enclosure.
- Note that the enclosure of the device can become very hot depending on the surrounding air temperature and output load connected to the device. Risk of burns!
- The main power must be turned off before connecting or disconnecting wires to the terminals.
- DO NOT insert any objects into the unit.
- Dangerous voltages present for at least 5 minutes after disconnected all sources of power.
- The power supplies are built in units and must be installed in a cabinet or room (condensation free environment and indoor location) that is relatively free of conductive contaminants.
- The power supply shall be installed within service maintenance area only; and the cord connector or attachment plug shall not be disconnected while the power supply and system are still running.

# CliQ M DIN Rail Power Supply

## 24V 960W 1 Phase / DRM-24V960W1PN

### Functions

#### DC OK Relay Contacts and LED Indicator Characteristics

| DC OK Relay Contacts Status | Characteristics   |
|-----------------------------|---|
| Contact closes              | The output voltage reaches 95% of its steady state set value. The contact will close within 1000ms.   |
| Contact opens               | The output voltage dip lower than 90% of its steady state set value: <ul style="list-style-type: none"> <li>Output voltage dip duration less than 2ms will be ignored.</li> <li>Output voltage dip duration more than 2ms. The contact will open within 15ms and remain open for an extended duration up to 350ms max.</li> </ul> |
| Contact re-closes           | The output voltage reaches 90% of its steady state set value. The contact will close in 350ms max.  |

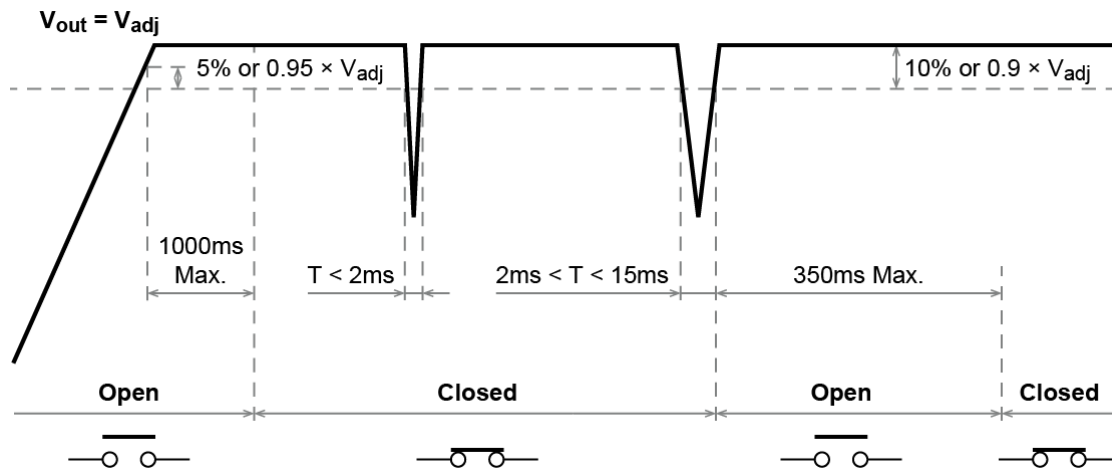

| Operating Status                                    | DC OK (Green LED) | Overload (Red LED) | DC OK Relay Contact |
|---|-------------------|--------------------|---------------------|
| Normal Operation                                    | ON                | OFF                | Closed              |
| During Power Boost                                  | ON                | OFF                | Closed              |
| Overload ( $V_{out} \leq 90\%$ of adjusted voltage) | OFF               | Flashing           | Open                |
| Output Short Circuit                                | OFF               | Flashing           | Open                |
| Over Temperature                                    | OFF               | Flashing           | Open                |
| No Input Power                                      | OFF               | OFF                | Open                |
| Active shut down input                              | OFF               | Flashing           | Open                |

# CliQ M DIN Rail Power Supply

## 24V 960W 1 Phase / DRM-24V960W1PN

### Single/Parallel Selection

This select jumper on the front of the power supply unit (refer to Device Description, item 7 in page 9) enables load sharing when power supplies are connected in parallel. When the jumper is in parallel mode, the output voltage will droop down around 4% from no load to maximum load. If the jumper is not plugged in, the power supply unit functions in single mode. Default factory setting jumper is in single mode.

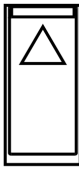
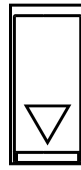
| Parallel Selection  | Single Selection  |
|---|---|
| <p><b>Parallel</b></p>  <p><b>Single</b></p> | <p><b>Parallel</b></p>  <p><b>Single</b></p> |

Instructions for Parallel Mode:

Ensure that output voltage is adjusted to  $V_o + 1V (\pm 0.1V)$  in "Parallel Mode" at no load conditions on all units.

$V_o$  = output voltage at maximum load conditions in parallel mode.

Example:

$V_o$  at maximum load = 24V. The output voltage adjusted for parallel mode at no load should be  $(V_o + 1V) 24 + 1 = 25V (\pm 0.1V)$ .

### Shut-Down Input Characteristics

This feature allows a switch-off of the output of the power supply with a signal switch or an external voltage.

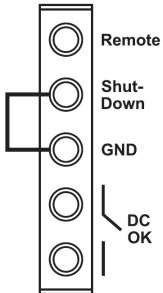
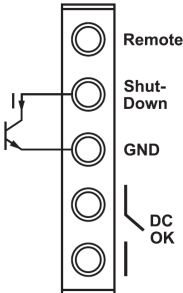
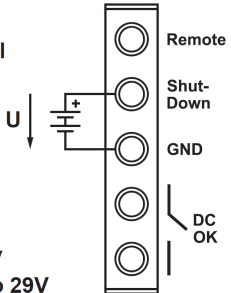
|   |  |  |
|---|--|--|
| <p><b>Option A:</b></p>  <p>Remote<br/>Shut-Down<br/>GND<br/>DC OK</p> <p><b>OFF: Linked</b><br/><b>ON: Open</b></p> | <p><b>Option B:</b><br/>(via open collector)</p>  <p>Remote<br/>Shut-Down<br/>GND<br/>DC OK</p> <p><b>OFF: <math>I &gt; 0.3mA</math></b><br/><b>ON: <math>I &lt; 0.1mA</math></b></p> | <p><b>Option C:</b><br/>(via external voltage)</p>  <p>Remote<br/>Shut-Down<br/>GND<br/>DC OK</p> <p><b>OFF: <math>U &lt; 1V</math></b><br/><b>ON: <math>U = 4 \text{ to } 29V</math></b></p> |
|---|--|--|

- The shut-down function has no safety feature included.
- The shut-down occurs immediately while the turn-on is delayed up to 350ms.
- In a shut-down condition, the output voltage is  $< 2V$  and the output power is  $< 0.5W$ .
- In a series operation of multiple power supplies only wiring option "A" with individual signal switches is allowed.
- Please note that option C requires a current sink capability of the voltage source. Do not use a blocking diode.
- In option C the PSU should be ON at  $U = 4 \text{ to } 29V \pm 0.5V$

# CliQ M DIN Rail Power Supply

## 24V 960W 1 Phase / DRM-24V960W1PN

### Remote Control of Output Voltage Characteristics

Remote pin function is to control the output voltage between typically 22Vdc and 28Vdc.

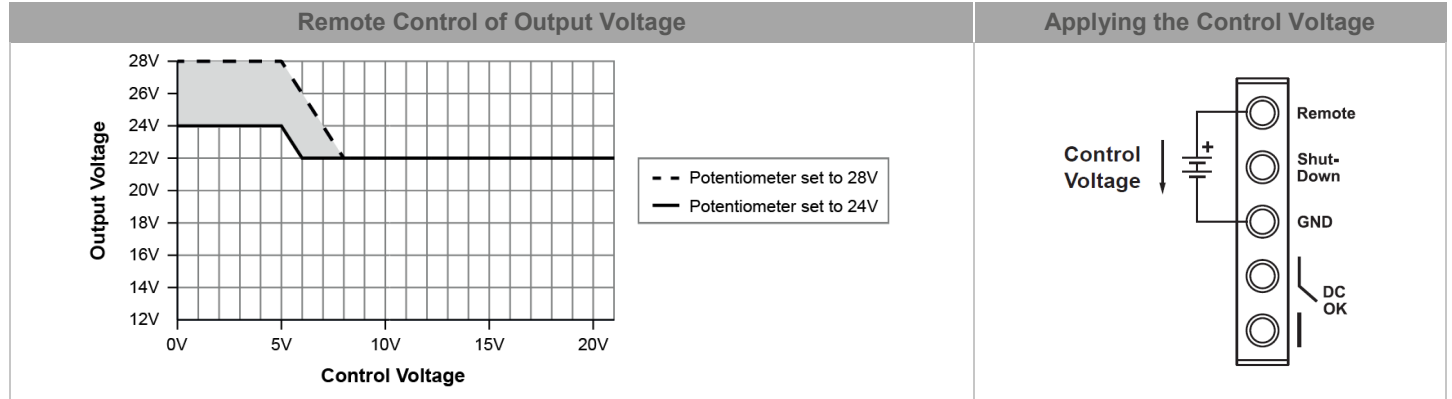

Instructions:

- Set the unit into "Single mode".
- Set the output voltage adjustment to the maximum desired voltage.
- Apply a control voltage to reduce the output voltage.

### Internal Data Logging

A protected microcontroller inside the power supply acquires and stores operating data during the life of the unit. The data can be downloaded with a small tool and special software by the Delta service and repair personnel even when the unit is defect. The data allows for better troubleshooting. Analysis of what happened before a failure can be determined much more accurately.

Acquired data:

- Family name of unit (M24V960W1PN), revision of firmware
- Operational hours
- Expired portion of lifetime (combination of temperature and period of time)
- Maximum internal ambient temperatures with timestamp (max 19 values)
- Maximal AC input voltages with timestamp (max 19 values)
- Failure report (various internal errors)
- Number and timestamp of input overvoltage transients
- Number and timestamp of over-temperature shut-downs
- Number of turn-on sequences

The data will be acquired with a fixed sampling rate unless the peak detectors do trigger due to an abnormal condition. In such cases, the abnormal condition will be captured. Furthermore, data will be acquired every time shortly before the unit switches off.

# CliQ M DIN Rail Power Supply

## 24V 960W 1 Phase / DRM-24V960W1PN

■ Graph illustrating the Start-up Time, Rise Time, and Hold-up Time

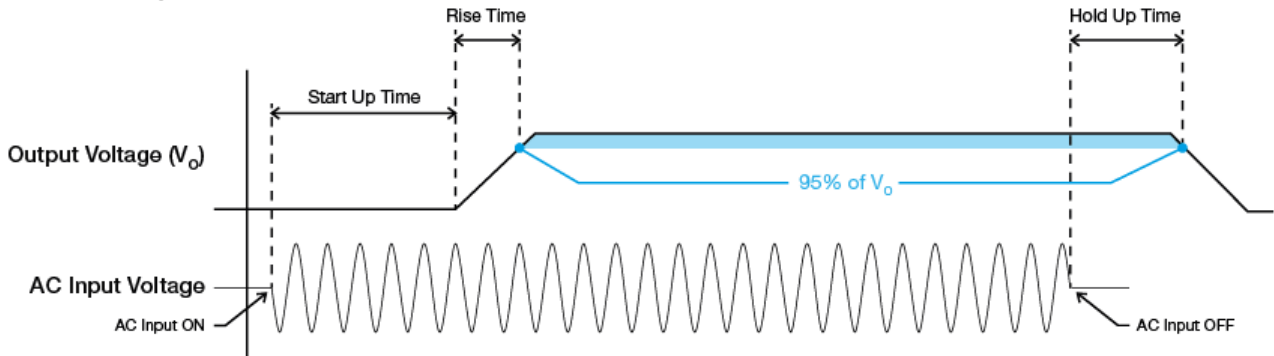

### Start-up Time

The time required for the output voltage before output voltage rise up, after the input voltage is applied.

### Rise Time

The time required for the output voltage to change from 0% to 95% of its final steady state set value.

### Hold-up Time

Time between the collapse of the AC input voltage, and the output falling to 95% of its steady state set value.

### Inrush Current

Inrush current is the peak, instantaneous, input current measured and, occurs when the input voltage is first applied. For AC input voltages, the maximum peak value of inrush current will occur during the first half cycle of the applied AC voltage. This peak value decreases exponentially during subsequent cycles of AC voltage.

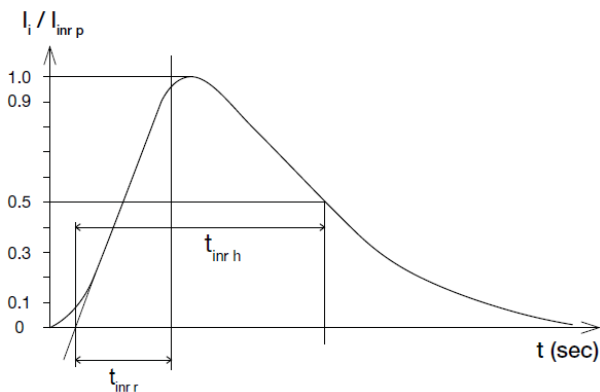

### Dynamic Response

The power supply output voltage will remain within  $\pm 5\%$  of its steady state value, when subjected to a dynamic load from 1.75% to 100% of its rated current.

■ 50% duty cycle / 5Hz to 1KHz

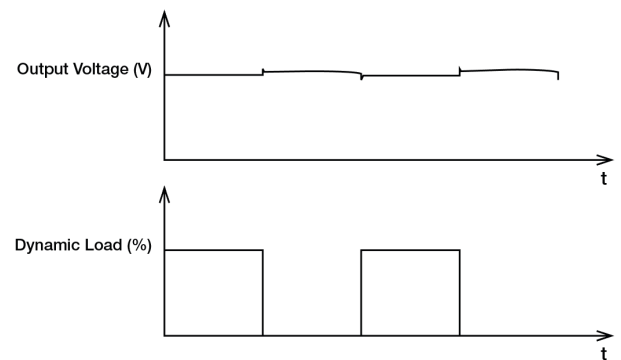



# CliQ M DIN Rail Power Supply

## 24V 960W 1 Phase / DRM-24V960W1PN

### Overvoltage Protection (Auto-Recovery)

The power supply's overvoltage circuit will be activated when its internal feedback circuit fails. The output voltage shall not exceed its specifications defined on Page 6 under "Protections".

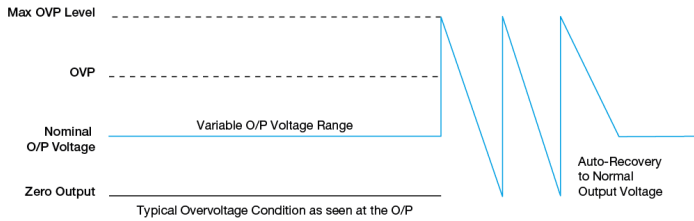

### Overload & Overcurrent Protections (Auto-Recovery)

The power supply's Overload (OLP) and Overcurrent (OCP) Protections will be activated when output current is  $> 150\%$  of  $I_o$  (output current). When this occurs, the output current will limit to 42A typ. (refer to Ⓐ below) and  $V_o$  (output voltage) will start to droop. Once  $V_o$  is below approximately 20Vdc typ., the power supply will start to operate in "Hiccup mode" as described in short circuit protection. The power supply will recover once the fault condition due to OLP or OCP is removed, then  $I_o$  is back within its specified limits.

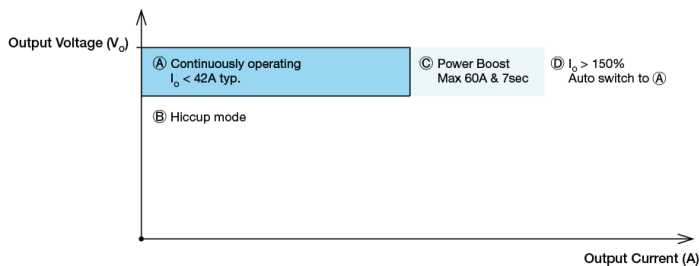

### Short Circuit Protection (Auto-Recovery)

The power supply's output Short Circuit Protection function also provides protection against short circuits. When a short circuit is applied, the output current will start to operate in "Hiccup mode". The power supply will return to normal operation after the short circuit is removed.

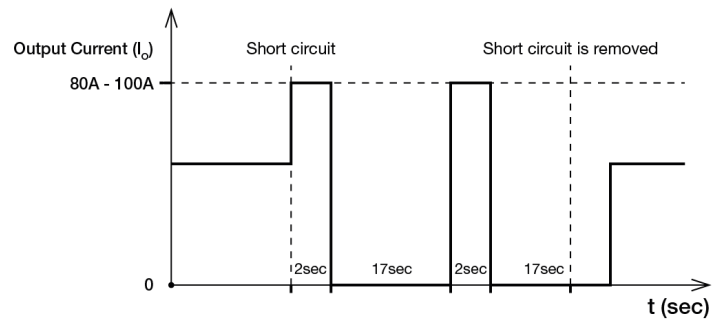

### Over Temperature Protection (Auto-Recovery)

As described in load de-rating section, the power supply also has Over Temperature Protection (OTP). In the event of a higher operating temperature at 100% load, the power supply will run into OTP when the operating temperature is beyond what is recommended in the de-rating graph. When activated, the output voltage will go into bouncing mode until the temperature drops to its normal operating temperature as recommended in the de-rating graph.

# CliQ M DIN Rail Power Supply

## 24V 960W 1 Phase / DRM-24V960W1PN

### Power Boost

Power Boost is the reserve power available constantly that allows reliable startup to support sudden and short spike of loads with high inrush current typically during turn on to remove the need of more expensive higher rated power supply unit. After the output has reached its steady state set value, the power supply can support surge loads with a higher short-term power demand up to 150% of maximum rated load ( $I_o$  Max), for a maximum duration of 7 seconds. If the power boost lasts longer than maximum duration, the output current will limit to 42A typ. and  $V_o$  (output voltage) will start to droop, refer to the details in overload & overcurrent protections and the next Power Boost will be available after power boost recovery time defined on Page 4. In order to avoid this, need to maintain the duty cycle & recovery time to ensure that average (R.M.S) output power shall not exceed the continuous maximum, see duty cycle calculation below.

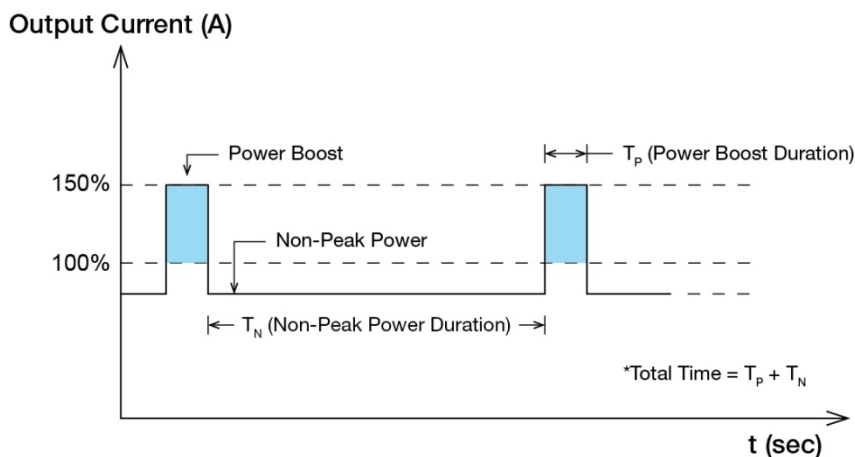

Fig. 7 Duty Cycle Calculation

$$Duty\ cycle\ (\%) = \frac{T_p}{Total\ Time}$$

$$Average\ Output\ Power\ (P_{Avg}) = \frac{(Power\ Boost \times T_p) + (Non-Peak\ Power \times T_n)}{Total\ Time}$$

OR

$$Non-Peak\ Power = \frac{(P_{Avg} \times Total\ Time) - (Power\ Boost \times T_p)}{T_n}$$

### ■ An example of Power Boost and Average Output Power

| Power Boost | Peak Power (W <sub>P</sub> ) | Power Boost Duration (T <sub>P</sub> ) | Duty Cycle | Non-Peak Power (W <sub>N</sub> ) | Non-Peak Power Duration (T <sub>N</sub> ) | Total Time (T) |
|-------------|------------------------------|--|------------|----------------------------------|---|----------------|
| 150%        | 1440                         | 1 sec                                  | 10%        | 907W                             | 9 sec                                     | 10 sec         |
| 150%        | 1440                         | 5 sec                                  | 30%        | 751W                             | 11.5 sec                                  | 16.5 sec       |
| 125%        | 1200                         | 1 sec                                  | 10%        | 933W                             | 9 sec                                     | 10 sec         |
| 125%        | 1200                         | 5 sec                                  | 30%        | 856W                             | 11.5 sec                                  | 16.5 sec       |

# CliQ M DIN Rail Power Supply

## 24V 960W 1 Phase / DRM-24V960W1PN

### Advanced Power Boost (APB)

With multiple loads connected in a system and due to one of fault load a large inrush current is drawn (demanded), this will be detected by APB. This APB can trip the external output protection device with appropriate rating based on system load. Thus preventing the system from shutting down while other connected current paths continue to operate without interruption.

The following waveforms demonstrate the behavior.

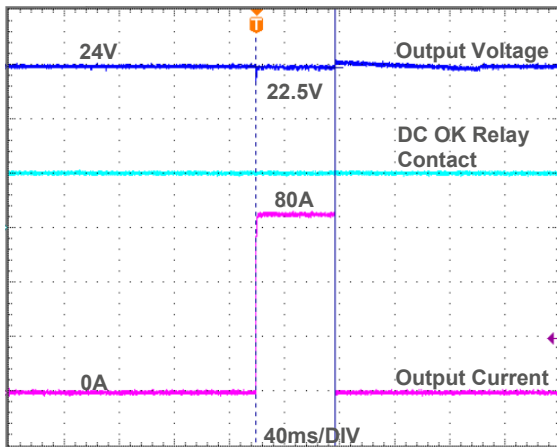

Fig. 8.1 APB 200% of nominal output current for 50ms

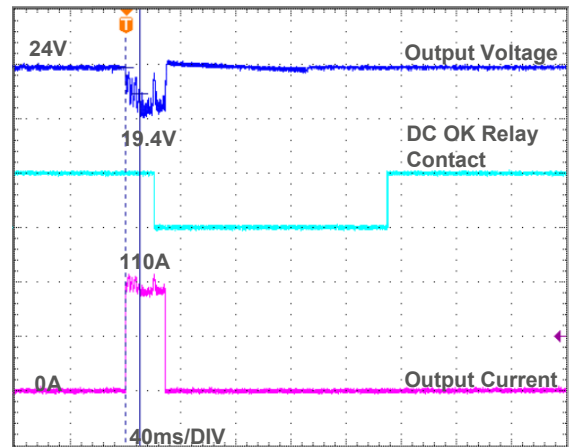

Fig. 8.2 APB 275% of nominal output current for 25ms

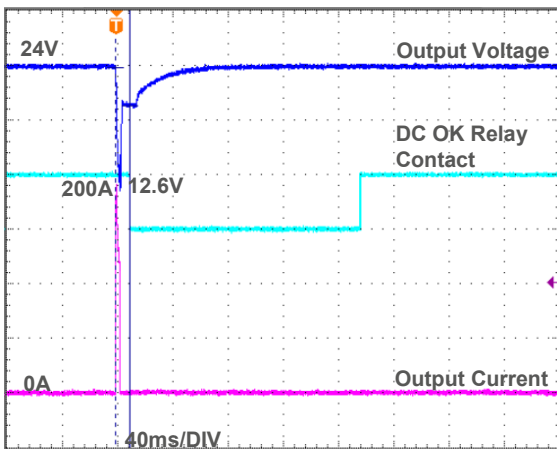

Fig. 8.3 APB 500% of nominal output current for 2ms

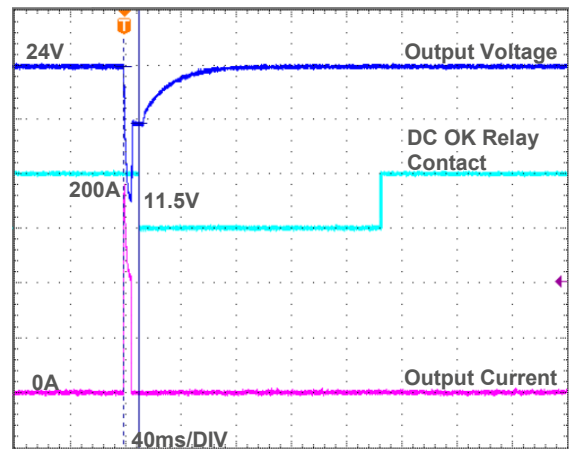

Fig. 8.4 APB 500% of nominal output current for 5ms

### External Input Protection Device

The unit is protected at the L pin, with an internal fuse that cannot be replaced. The power supply has been tested and approved on 30A (UL) and 32A (IEC) branch circuits without additional protection device. An external protection device is only required if the supplying branch has an ampacity greater than above. Thus, if an external protective device is necessary, or, utilized, please refer a minimum value in instruction sheet with B or C characteristic breaker.

# CliQ M DIN Rail Power Supply

## 24V 960W 1 Phase / DRM-24V960W1PN

### Operating Mode

#### ■ Redundant Operation

In order to ensure proper redundant operation for the power supply units (PSUs), follow simple steps given below to set them up for the redundant operation:

##### Step 1.

In order to set the output voltage, ensure that each power supply is selected in "Parallel Mode" at no load conditions at any line voltage from 85-264Vac, and set the PSU 1 and PSU 2 output voltage to  $V_o^* + 1V (\pm 0.1V)$ .

##### Step 2.

Connect the right DRR module, 40A as per the system requirement to the power supply units. PSU 1 should be connected to DRR Module 1 at  $V_{in 1}$  and  $V_{in 2}$ , and PSU 2 should be connected to DRR Module 2 at  $V_{in 1}$  &  $V_{in 2}$  as shown on the Fig 8.

##### Step 3.

Connect the system load from  $V_{out}$ . Please note that output voltage  $V_{out}$  from DRR module will be =  $V_o$  (output voltage of power supply) -  $V_{drop}^{**}$  (in DRR module).

\* $V_o$  = output voltage at maximum load conditions in parallel mode

\*\* $V_{drop}$  will vary from 0.60V to 0.90V (Typical 0.65V) depending on the load current and surrounding air temperature.

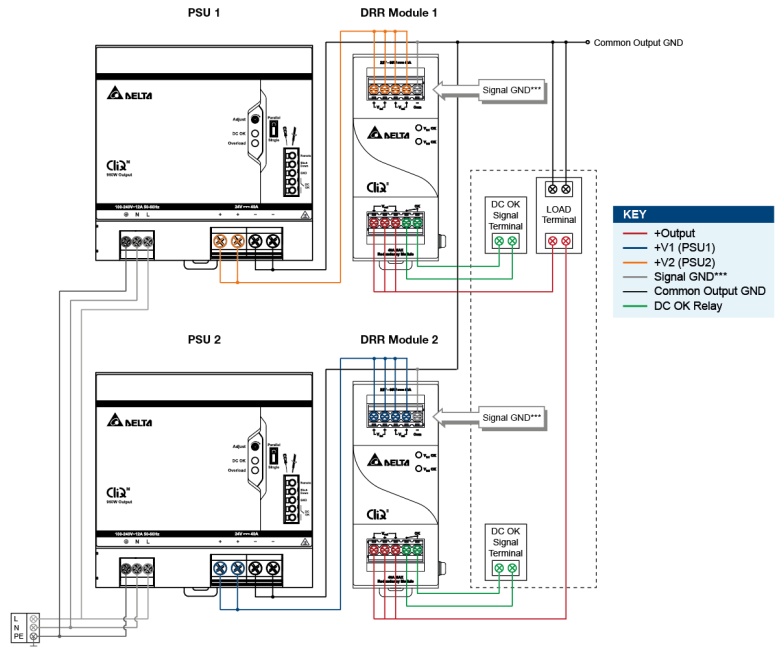

\*\*\*The Signal GND in the DRR module is for the built-in LED and DC OK signals. The Output GND terminals from the two PSU's do not need to be connected to the Signal GND terminal.

Fig. 9 Redundant Operation Connection Diagram

#### ■ Parallel Operation

The power supply units (PSUs) can also be used for parallel operation in order to increase the output power. The output voltage of each power supply shall be adjusted to the same value. In order to set the output voltage, ensure that each power supply is selected in "Parallel Mode" at no load conditions at any line voltage from 85-264Vac, and set the PSU 1 and PSU 2 output voltage to  $V_o^* + 1V (\pm 0.1V)$ .

If more than three units are connected in parallel, a fuse or circuit breaker with a rating of 50A or 63A is required on each output. Alternatively, a diode or DRR Module can also be utilized.

Parameters such as EMI, inrush current, leakage current, PARD, start up time will be different from those on the datasheet, when two units are connected in parallel. The user will need to verify that any differences will still allow the two power supplies connected in parallel will work properly in their product/application.

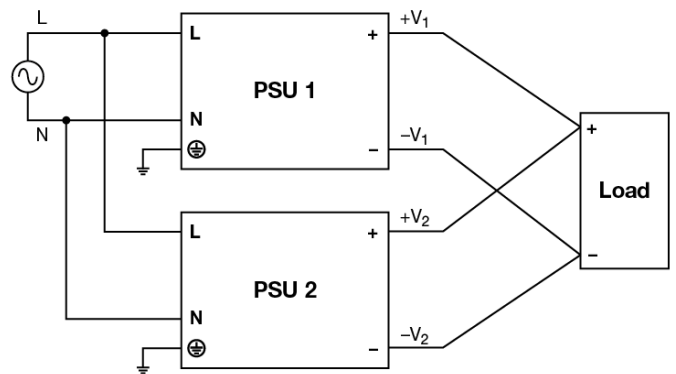

Fig. 10 Parallel Operation Connection Diagram

# CliQ M DIN Rail Power Supply

## 24V 960W 1 Phase / DRM-24V960W1PN

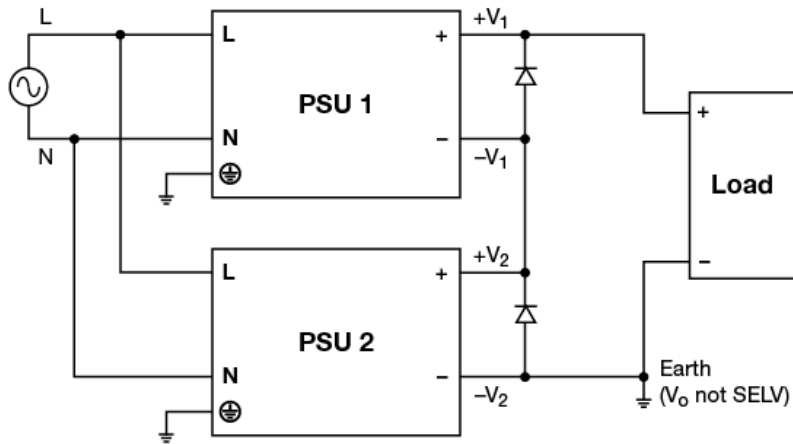
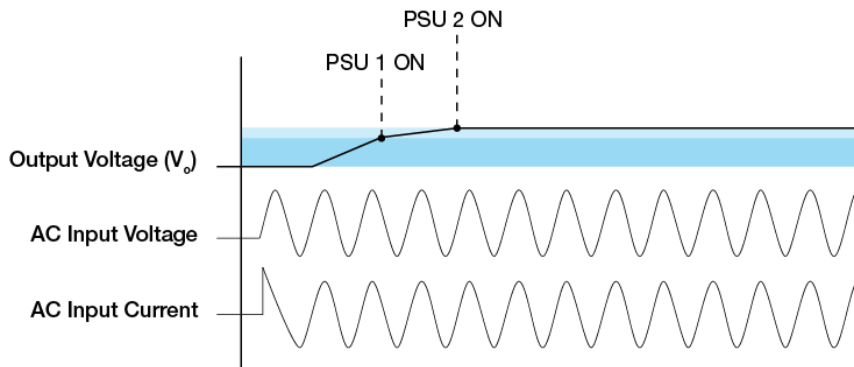

Fig. 11 Series Operation Connection Diagram

### Series Operation

Delta's CliQ M can be connected in series to increase the output voltage as shown in figure above. Only power supply from the same product series, and with the same rated output current, can be used. The maximum load current should not exceed the smallest rated output current. Any number of power supplies can be connected in series. User must note that an output voltage > 60Vdc will not meet SELV requirements and could be dangerous to user, the total voltage shall not exceed 150Vdc. Installation a protection against the touching is a must and connect the output ground to earth when output voltage is not SELV. A diode in reverse bias must be added across output terminals of each power supply, this is to prevent -V voltage being applied to other power supply in fault conditions such as short circuit across load. During the short circuit -V<sub>1</sub> & +V<sub>1</sub> will come across +V<sub>2</sub> & -V<sub>2</sub> which means connecting 2 power supplies in opposite polarity and may cause damage to power supply. With reverse bias diodes in place the voltage across each power supply will be restricted to one diode drop – approximately 0.7V to 1.0V. It is recommended to provide sufficient voltage de-rating for diodes with 2 times the voltage rating of series output voltage. E.g. the two 24V power supplies are connected in series, the total voltage is 48 volts. Hence, recommended to use diodes with reverse voltage rating of 2x48=96 volts. Therefore diodes with reverse voltage rating of 100 volts can be used.

During the short circuit condition, the current through diodes will be large, hence it is recommended that diodes to be least twice the current rating of the power supply.



The turn ON would be non-monotonic as the power supply with the fastest startup time and rise time will turn on first. As a result, the combined output voltage waveform of the 2 power supplies connected in series will include a step.

User must consider to verify parameters such as EMI, inrush current, leakage current, PARD, start up time would differ from datasheet numbers as multiple power supplies in series.

# CliQ M DIN Rail Power Supply

## 24V 960W 1 Phase / DRM-24V960W1PN

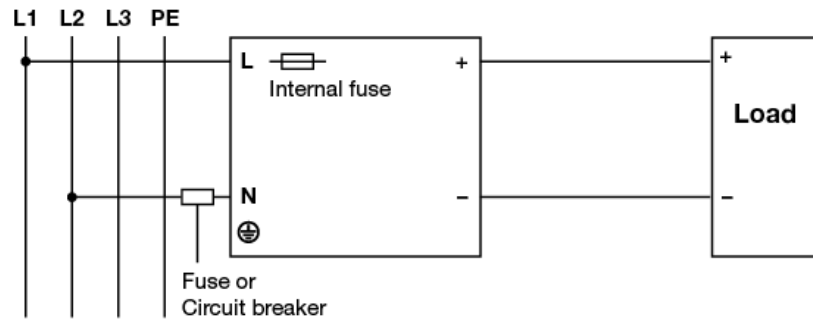

Fig. 12 2 of 3 Phase System Input Operation Connection Diagram

### ■ 2 of 3 Phase System Input Operation

Delta's CliQ M can use on 2 of 3 phase system. Please refer to the following step.

#### Step 1.

The input voltage applied from Line to Neutral is below the maximum rated input. The input voltage shall be below 240Vac +10%.

#### Step 2.

The external protector is needed on N (Neutral) input line to secure a safety. N line does not have internal fuse protection. An appropriate fuse or circuit breaker should be connected in series with N input line connection like the following.

# CliQ M DIN Rail Power Supply

## 24V 960W 1 Phase / DRM-24V960W1PN

### Others

#### Delta RoHS Compliant



#### Restriction of the usage of hazardous substances

The European directive 2011/65/EU limits the maximum impurity level of homogeneous materials such as lead, mercury, cadmium, chrome, polybrominated flame retardants PBB and PBDE for the use in electrical and electronic equipment. RoHS is the abbreviation for “Restriction of the use of certain hazardous substances in electrical and electronic equipment”.

This product conforms to this standard.

#### Conformal Coating

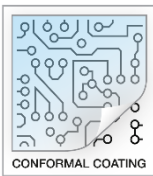

#### The Protective Coating Technology

Delta Electronics Group has designed the perfect dipping technique which penetrates everywhere including under device, and prevents leakage. The conformal coating dipping can be applied to PCBAs or circuit board. The coating preserves the performance of precision electronic primarily by preventing ionizable contaminants such as salt from reaching circuit nodes, where the material slumps around sharp edges. This can be a problem especially in highly conversing atmosphere.

#### PFC – Norm EN 61000-3-2

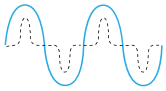

#### Line Current Harmonic content

Typically, the input current waveform is not sinusoidal due to the periodic peak charging of the input capacitor. In industrial environments, compliance with EN 61000-3-2 is only necessary under special conditions. Complying to this standard can have some technical drawbacks, such as lower efficiency; and, can also result in higher product cost. Frequently, the user does not profit from compliance to this standard; therefore, it is important to know whether it is mandatory to meet this standard for a specific application.

#### Attention

Delta provides all information in the datasheets on an “AS IS” basis and does not offer any kind of warranty through the information for using the product. In the event of any discrepancy between the information in the catalog and datasheets, the datasheets shall prevail (please refer to [www.DeltaPSU.com](http://www.DeltaPSU.com) for the latest datasheets information). Delta shall have no liability of indemnification for any claim or action arising from any error for the provided information in the datasheets. Customer shall take its responsibility for evaluation of using the product before placing an order with Delta.

Delta reserves the right to make changes to the information described in the datasheets without notice.

## Данный компонент на территории Российской Федерации

### Вы можете приобрести в компании MosChip.

Для оперативного оформления запроса Вам необходимо перейти по данной ссылке:

<http://moschip.ru/get-element>

Вы можете разместить у нас заказ для любого Вашего проекта, будь то серийное производство или разработка единичного прибора.

В нашем ассортименте представлены ведущие мировые производители активных и пассивных электронных компонентов.

Нашей специализацией является поставка электронной компонентной базы двойного назначения, продукции таких производителей как XILINX, Intel (ex.ALTERA), Vicor, Microchip, Texas Instruments, Analog Devices, Mini-Circuits, Amphenol, Glenair.

Сотрудничество с глобальными дистрибьюторами электронных компонентов, предоставляет возможность заказывать и получать с международных складов практически любой перечень компонентов в оптимальные для Вас сроки.

На всех этапах разработки и производства наши партнеры могут получить квалифицированную поддержку опытных инженеров.

Система менеджмента качества компании отвечает требованиям в соответствии с ГОСТ Р ИСО 9001, ГОСТ РВ 0015-002 и ЭС РД 009

### Офис по работе с юридическими лицами:

105318, г.Москва, ул.Щербаковская д.3, офис 1107, 1118, ДЦ «Щербаковский»

Телефон: +7 495 668-12-70 (многоканальный)

Факс: +7 495 668-12-70 (доб.304)

E-mail: [info@moschip.ru](mailto:info@moschip.ru)

Skype отдела продаж:

moschip.ru

moschip.ru\_4

moschip.ru\_6

moschip.ru\_9