

SPECIFICATION

SPEC. No. _____

D A T E : 2013 Feb.

To _____

Non-Controlled Copy

CUSTOMER'S PRODUCT NAME

TDK'S PRODUCT NAME

WOUND/STD INDUCTOR,
MAGNETIC SHIELDED
LGJ10145TS-H SERIES HIGH RELIABILITY
GRADE – See section 1 on page 1 for
Important Product Information

ALL ORDERS FOR THIS PRODUCT ARE SUBJECT TO THE TERMS AND CONDITIONS OF THIS SPECIFICATION

DATE: YEAR MONTH DAY

TDK Corporation
Sales
Electronic Components
Sales & Marketing Group

TDK-EPC Corporation
Engineering
Magnetics Business Group

APPROVED	Person in Charge

APPROVED	CHECKED	Person in Charge

1. SCOPE AND MEANING OF “HIGH RELIABILITY GRADE”

This specification is applicable to WOUND STD INDUCTOR/MAGNETIC SHIELDED with a priority over the other relevant specifications. Manufacturing places defined in this specification shall be TDK-EPC Corporation Japan, and TDK Components USA. Inc.

“High Reliability Grade” means that TDK's LGJ Series Inductors provide an extended life Inductor that meets or exceeds the electrical, mechanical and environmental performance standards from AEC Q200 Rev.D. Details are referenced within section 7 of this specification. It also means that, in addition to our highest quality Inductor, the customer will also receive access to an on-line Sigma Report (Enhanced Certificate of Compliance) and internet based product authentication for each lot (which includes electrical characterization data, and estimated product life, as well as anti-counterfeit packaging). Additionally RFID (radio frequency identification) tags are available as an option.

EXPLANATORY NOTE:

For warranty information, please refer to section 14 of this specification.

2. CODE CONSTRUCTION

(Example)

LGJ 10145 TS - 152 M R22 - H
(1) (2) (3) (4) (5) (6) (7)

- (1) Series Name
- (2) Dimension L x W x T (10145: 10.1mm x 10.1mm x 4.5mm)
- (3) Packaging Style (TS: Tape & Reel)
- (4) Inductance Value (3R3 = 3.3 μ H; 100 = 10 μ H)
- (5) Inductance Tolerance (M: \pm 20%; N: \pm 30%)
- (6) Rated Current (2R5 = 2.5A; R90 = 0.90A)
- (7) Operating Temperature Range (H: -40° C to +125° C)

3. SHAPES AND DIMENSIONS/CIRCUIT DIAGRAM

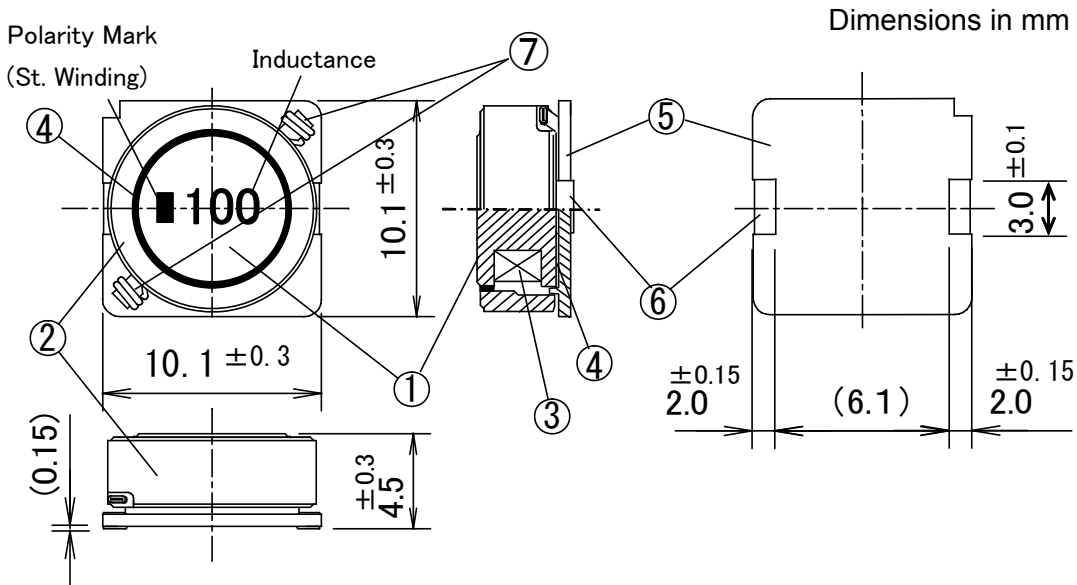

No.	ITEM NAME	MATERIAL
1	Drum core	Ferrite
2	Ring core	Ferrite
3	Winding wire	Polyurethane enameled copper wire
4	Glue	Epoxy resin
5	Base	Phenolic resin
6	Terminals	Tin plated copper(t=0.15)
7	Solder	Lead free solder(Sn-2Cu)

Note: 1) It is acceptable even if adhesive is out of ring core, but it shouldn't be out of base.

Note: 2) Even if the adhesives of an upper surface application have the portion which has not been buried completely, they presuppose that it is possible.

Note: 3) Values in parentheses are referential.

4. CHARACTERISTICS

Temperature rise : 30° C TYP. (IDC2)

Operating Temperature Range : -40° C to +125° C (Including Self Temperature Rise)

Storage Temperature Range : -40° C to +125° C

Rated current : Please see Section 5-1

Application

Reflow soldering can be used for this product while wave-flow can not be used.

The condition in soldering by hand should confirm to the heat capacitance corresponding to the test of resistance to soldering heat.

Equivalent Circuit

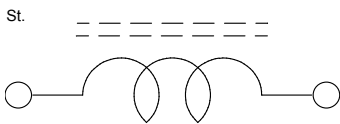

5. ELECTRICAL CHARACTERISTICS

5-1. Electrical Specifications

Customer Part Number	TDK Item Description	Inductance L (μ H) at 100kHz	DC resistance R_{DC} (Ω)	*Rated Current (A)		Marking
				I_{DC1} MAX	I_{DC2} TYPICAL	
	LGJ10145TS-3R3N3R7-H	3.3 \pm 30%	16.1m \pm 20%	4.9	3.7	■3R3
	LGJ10145TS-5R6M3R2-H	5.6 \pm 20%	22.0m \pm 20%	3.8	3.2	■5R6
	LGJ10145TS-100M2R5-H	10 \pm 20%	36.4m \pm 20%	3.0	2.5	■100
	LGJ10145TS-150M2R2-H	15 \pm 20%	47.2m \pm 20%	2.4	2.2	■150
	LGJ10145TS-220M1R9-H	22 \pm 20%	59.1m \pm 20%	2.1	1.9	■220
	LGJ10145TS-330M1R6-H	33 \pm 20%	81.5m \pm 20%	1.6	1.7	■330
	LGJ10145TS-470M1R4-H	47 \pm 20%	0.10 \pm 20%	1.4	1.5	■470
	LGJ10145TS-680M1R2-H	68 \pm 20%	0.14 \pm 20%	1.2	1.3	■680
	LGJ10145TS-101M1R0-H	100 \pm 20%	0.20 \pm 20%	1.0	1.1	■101
	LGJ10145TS-151MR79-H	150 \pm 20%	0.35 \pm 20%	0.79	0.81	■151
	LGJ10145TS-221MR65-H	220 \pm 20%	0.47 \pm 20%	0.65	0.70	■221
	LGJ10145TS-331MR54-H	330 \pm 20%	0.68 \pm 20%	0.54	0.58	■331
	LGJ10145TS-471MR47-H	470 \pm 20%	1.03 \pm 20%	0.47	0.47	■471
	LGJ10145TS-681MR38-H	680 \pm 20%	1.6 \pm 20%	0.38	0.38	■681
	LGJ10145TS-102MR29-H	1000 \pm 20%	2.8 \pm 20%	0.32	0.29	■102
	LGJ10145TS-152MR22-H	1500 \pm 20%	3.4 \pm 20%	0.22	0.26	■152

*Rated current : the less value which is IDC1 or IDC2.

(Current is D.C. current)

IDC1 : Based on inductance change(Δ L:-10% MAX from initial L value.)

IDC2 : Based on temperature rise(Δ T:30°C TYP.)

Test Instruments

L : 4194A IMPEDANCE/GAIN-PHASE ANALYZER, HP OR EQUIV.

RDC : MILLIOHM METER VP-2941A MATUSITA OR EQUIV.

L(IDC1) : 4284A PRECISION LCR METER, HP with 42841A BIAS CURRENT SOURCE, HP / 42842A TEST FIXTURE, HP OR EQUIV.

6. STORAGE TERMS AND CONDITIONS

6-1. Storage condition before mounting:

5° C to 30° C at 20 to 75% RH Max

Use within 6 months from delivery date

Solderability might be decreased if the period is exceeded.

7. PERFORMANCE

No.	Item	Performance	Test Condition / Inspection Method
1	High Temperature Exposure (Storage)	$\Delta L/L0 \leq \pm 5\%$ There shall be no mechanical damage.	MIL-STD-202 Method 108 125° C / 2000h
2	Temperature Cycling	$\Delta L/L0 \leq \pm 5\%$ There shall be no mechanical damage.	JESD22 Method JA-104 -40/+125° C (Dwell 30min) / 2000cycles
3	Biased Humidity	$\Delta L/L0 \leq \pm 5\%$ There shall be no mechanical damage.	MIL-STD-202 Method 103 85° C 85%R.H. / 2000h
4	Operational Life	$\Delta L/L0 \leq \pm 5\%$ There shall be no mechanical damage.	MIL-PRF-27 95° C / 2000h Current rating is energized.
5	External Visual	No Visual Damage	MIL-STD-883 Method 2009
6	Physical Dimensions	Section 3. Shapes and Dimensions	JESD22 Method JB-100 Length , Width , Height dimension
7	Resistance to Solvents	No Visual Damage	MIL-STD-202 Method 215
8	Mechanical Shock	$\Delta L/L0 \leq \pm 5\%$ There shall be no mechanical damage.	MIL-STD-202 Method 213 Method 213 Peak:100G Half-sine / Duration:6ms / Number of times:6axis x 3times
9	Vibration	$\Delta L/L0 \leq \pm 5\%$ There shall be no mechanical damage.	MIL-STD-202 Method 204 10-2000Hz / 5G or 1.52mmP-P / 20 min x 12 cycles x 3axis
10	Resistance to Soldering Heat	$\Delta L/L0 \leq \pm 5\%$ There shall be no mechanical damage.	MIL-STD-202 Method 210 Test Type: Dip Solder: 260° C Dipping Time:10sec
11	Solderability	Covered by New Solder over 95%.	J-STD-002 Method B, 4hrs@235° C, category 3 J-STD-002 Method B, @215° C, category 3
12	Electrical Characterization	$\Delta L/L20^\circ C \leq \pm 15\%$	Inductance change rate based on 20° C (-40~125° C)
13	Board Flex	$\Delta L/L0 \leq \pm 5\%$ There shall be no mechanical damage.	AEC-Q200-005 2mm / 60sec
14	Terminal Strength (SMD)	$\Delta L/L0 \leq \pm 5\%$ There shall be no mechanical damage.	AEC-Q200-006 17.7N / 60sec

8. RECOMMENDED FOOTPRINT

8-1. Land Pattern Dimension (ref)

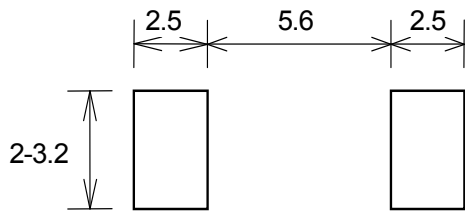

Adjacent land patterns and lines on the PCB should be covered with resist.

Dimensions in mm

8-2. Test PCB Dimension

Substrate Bending Test Board
Glass epoxy t = 1.6mm

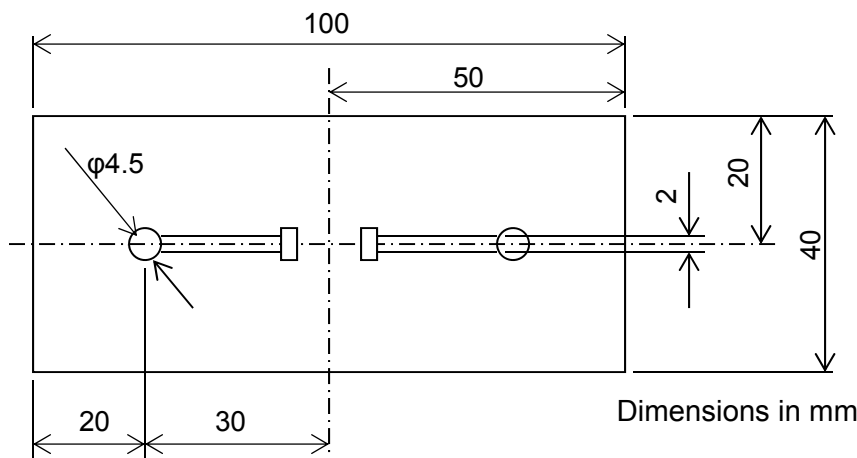

Dimensions in mm

9. RECOMMENDED SOLDERING PROFILE (REFLOW ONLY)

9-1. Profile for Pb-Free Solder

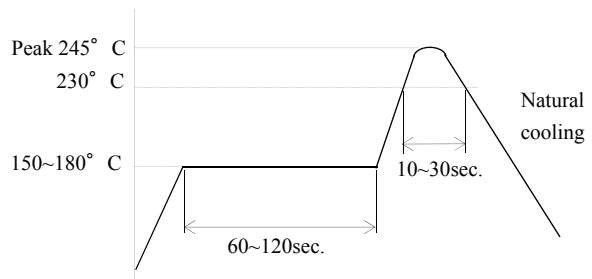

9-2. Profile for Sn-Pb Solder

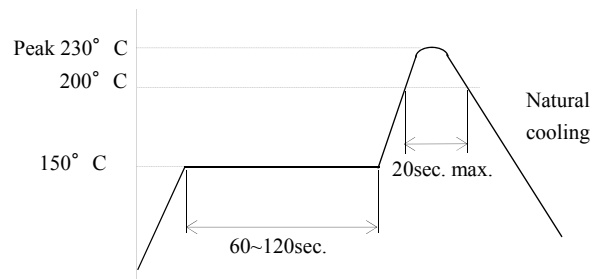

9-3. Iron Soldering

Use a solder iron of less than 30W. When soldering, do not allow the soldering iron tip to directly touch the ferrite body outside of the terminal electrode. 3 seconds max. at 350° C.

10. PACKAGING SPECIFICATION

10-1. Dimensions of carrier tape

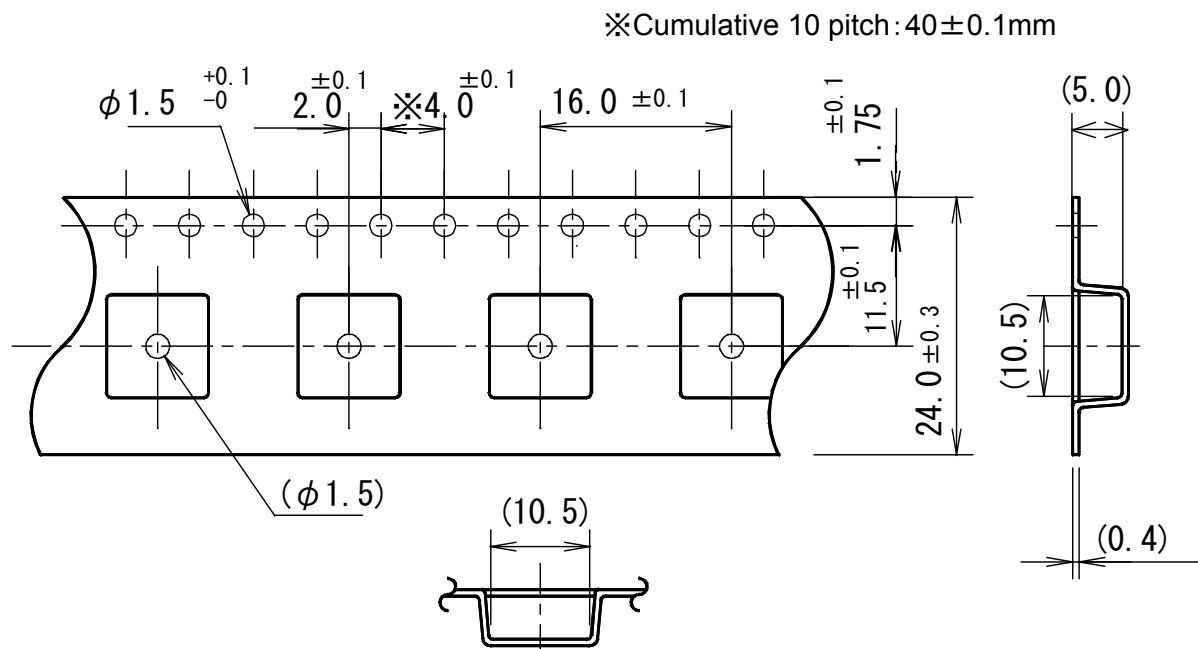

Packaging Format: EIAJ-RC-1009B
Dimensions in mm

10-2. Dimensions of carrier tape

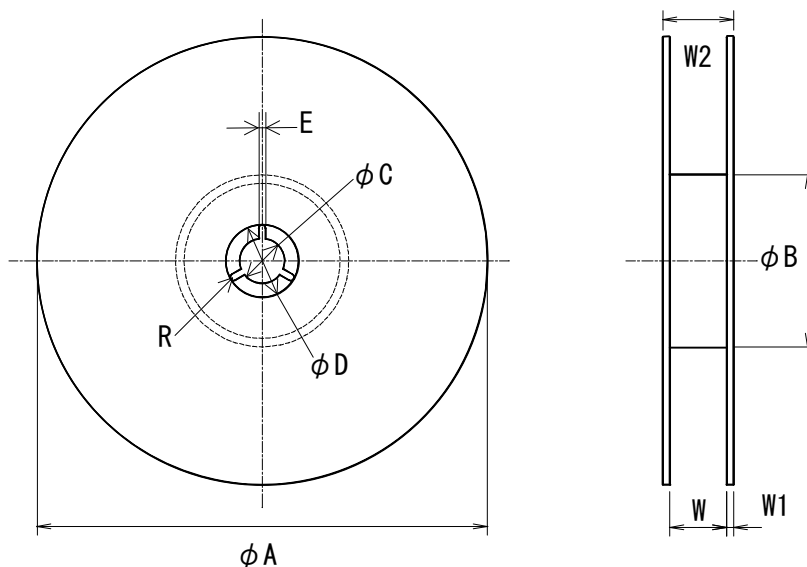

Dimensions in mm

ϕA	ϕB	ϕC	ϕD	E	W	W1	W2	R
330 ± 2	50 or more	13.0 ± 0.5	21.0 ± 0.8	2.0 ± 0.5	$24.4 +2/-0$	2.0 ± 0.5	30.4 or less	(1.0)

10-3. Quantity: 500 pcs/Reel

10-4. The products are packaged so that no damage will be sustained.

10-5. Bulk part and leader of tape

(QUANTITY : 500PCS.)

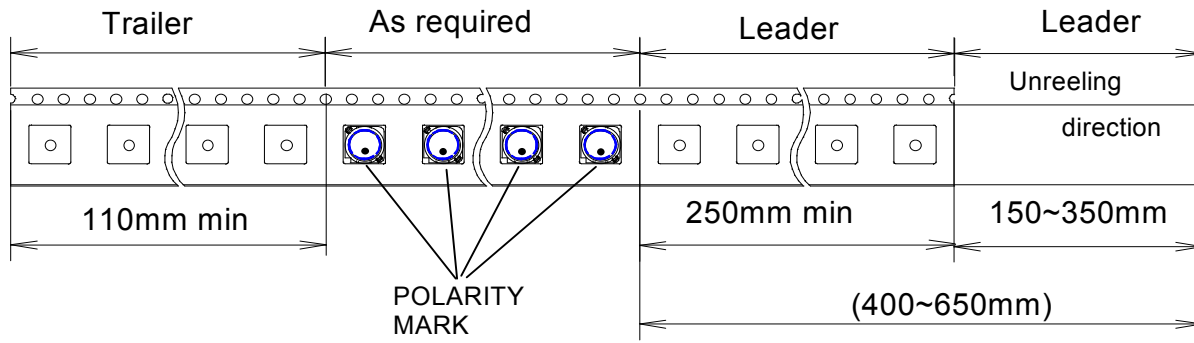

11. PACKAGING LABEL

11-1. Packaging shall be done to protect the components from the damage during transportation and storing, and a label which has the following information shall be attached.

- 1) Inspection No.
- 2) TDK P/N
- 3) Customer's P/N
- 4) Quantity

*Composition of Inspection No.

Example F 2 A – OO – OOO
 (a) (b) (c) (d) (e)

- a) Line code
- b) Last digit of the year
- c) Month and A for January and B for February and so on. (Skip I)
- d) Inspection Date of the month.
- e) Serial No. of the day



11.2 Anti-counterfeit Label

The anti-counterfeit label with a unique identification code is placed over the reel flanges to ensure material authenticity. Product authentication can be confirmed by visiting TDK.com and entering the requested information. The secure on-line system will provide an immediate response to the authenticity of the TDK product from the information provided.



DO NOT USE if the seal is broken or evidence of tampering is present. Contact your local TDK representative for further instructions.

TDK's RFID reel tags are commissioned with lot specific information such as: lot number, customer part number, and quantity. RFID reel tag data can be customized to meet individual customer RFID requirements, as up to 64 bits of data can be stored on the RFID tag. Please contact your TDK sales representative for more information regarding customized information for RFID reel tags. Below is an example of TDK standard RFID reel tag data (red font indicates data identifiers).

PLGJ10145TS-680M1R2-H, 1PLGJ10145TS-680M1R2-H, Q500
 (customer part no.) (TDK item description) (reel quantity)

TDK's RFID tag is compliant to ISO/IEC 18000-6 :2010 requirements and can be read within the standard operating frequency range for the United States (902-928Mhz) and international regulated frequencies within the Ultra High Frequency (UHF) bandwidth for Europe (865-868Mhz) and Japan (952-957Mhz).

12. SIGMA REPORT (ENHANCED CERTIFICATE OF COMPLIANCE)

The Sigma Report, an enhanced Certificate of Compliance will be performed for each lot. The results will be available on-line by visiting TDK.com and entering the requested information.

The Sigma Report will include performance (electrical and mechanical) and reliability metrics (FIT and MTTF).

A list of test completed is provided in Table 12.1.

Table 12.1

Ref	Test
1	Appearance
2	Dimensions
3	Inductance
4	DC Resistance
5	Solderability

13. NOTE

- 13-1. If there occurs something to be discussed, it should be treated on deliberation between customer and TDK-EPC Corporation.
- 13-2. Please don't use the product that experienced falling.
However, If the falling is from less than 20cm high to vinyl-tile-like ground, The product with normal appearance and characteristics can be used.
- 13-3. Please don't apply the stress more 19.6N onto the top of the product.
- 13-4. If acoustic noise was occurred by magnetostrictive, it is preferable that reject or attenuate the audible frequency of current.

14. WARRANTY

TDK's LGJ Series Inductors are designed and warranted to meet the performance standards shown in Section 7 (Performance Table) of this specification using the test and inspection methods specified therein.

While LGJ Series Inductors are intended for high reliability applications within the range of conditions set forth in this specification, TDK is not aware of all applications in which these parts may be used, or the requirements of your particular application.

This series is not designed or warranted to meet any specifications of any intermediate or end user different from or in addition to those contained in this specification, nor are they intended or warranted for use in the Excluded Applications below.

Excluded Applications :

- Aerospace/aviation equipment (where the application is related to flight);
- FDA Class III medical equipment (and including any in-the-body medical application or any other medical application where failure of the TDK part could possibly endanger human life or health);
- Nuclear energy-related equipment; and/or
- Military equipment (where related to (i) destructive functionality including ammunition, firearms, warheads, mines and/or bombs, or (ii) discharging, emitting or blast-off functionality including artillery or missiles, or (iii) military aircraft or spacecraft).

Additionally, if you intend to use TDK's LGJ Series Inductors in any of the applications listed below ("Specialized Applications"), you should carefully review the requirements of the your particular application as against this specification so as to ensure the suitability of these parts for that application. TDK cannot ensure the suitability of these parts for the Specialized Applications below:

Specialized Applications :

- FDA Class I and II medical equipment (with the sale of parts for FDA Class II applications subject to prior TDK consultation).
- Transportation equipment (electric trains, ships, etc.)
[other than automotive applications];
- Transportation control equipment;
- Power-generation control equipment;
- Seabed equipment;
- Public information processing equipment;
- Electric heating apparatus and/or burning equipment;
- Disaster/crime prevention equipment; and/or
- Safety equipment.

TDK MAKES NO OTHER WARRANTIES, EXPRESS OR IMPLIED, INCLUDING THE WARRANTIES OF MERCHANTABILITY AND/OR FITNESS FOR A PARTICULAR PURPOSE. IN NO EVENT SHALL TDK BE RESPONSIBLE FOR ANY DAMAGE OR LIABILITY CAUSED BY USE OF THESE PARTS IN ANY OF THE EXCLUDED APPLICATIONS LISTED ABOVE OR FOR ANY OTHER USE EXCEEDING THE RANGE OR CONDITIONS SET FORTH IN THIS SPECIFICATION.

Please note that when designing your product, device, or equipment-even for general purpose applications - you should secure a protection circuit/device or provide backup circuits in your product, device, or equipment.

15. CAUTIONS

Please read the instructions here before you use this product

INSTRUCTIONS FOR USING THIS PRODUCT

STORAGE

- * Store this product under the conditions which are defined in the catalogue or the instruction book. Confirm the soldering property before using if you have stored the product over the conditions which are defined in the catalogue or the instruction book.
- * Do not use or store in locations where there are gas, corrosion (salt, acid alkaline, etc.)
- * Avoid the direct rays of the sun and dew condensation.
- * Do not expose the product to magnets or magnetic fields.

USING CONDITIONS

- * Use this product under the conditions which are defined in the catalogue or the instruction book. Temperature range and soldering property are especially to be noticed.
- * This product is designed for public welfare. If you are to use it for other purposes and if it is beyond the conditions in the instruction book , you should make a good examination beforehand.
- * Don't use this product in locations:
 - Exposed to water or seawater.
 - With excessive moisture exposure.
 - Do not use this product in locations where there are gas corrosion (salt, acid, alkaline, etc.)
 - With vibrations and impulses which are not defined in the instruction book.
- * When soldering is touched up after reflow to the PC Board, confirm the conditions which are defined in the catalogue or the instruction book.
- * If it is heated excessively , the product may experience conditions such as short circuit , rough contact, lowering of characteristic and shortening of its life.
- * Do good washing after soldering and make sure there is no residue left.
- * Dry thoroughly after washing.
- * Don't use the product if it is mechanically dropped.
- * Pay attention to stresses to the product by bending of the PC Board.

Данный компонент на территории Российской Федерации

Вы можете приобрести в компании MosChip.

Для оперативного оформления запроса Вам необходимо перейти по данной ссылке:

<http://moschip.ru/get-element>

Вы можете разместить у нас заказ для любого Вашего проекта, будь то серийное производство или разработка единичного прибора.

В нашем ассортименте представлены ведущие мировые производители активных и пассивных электронных компонентов.

Нашей специализацией является поставка электронной компонентной базы двойного назначения, продукции таких производителей как XILINX, Intel (ex.ALTERA), Vicor, Microchip, Texas Instruments, Analog Devices, Mini-Circuits, Amphenol, Glenair.

Сотрудничество с глобальными дистрибьюторами электронных компонентов, предоставляет возможность заказывать и получать с международных складов практически любой перечень компонентов в оптимальные для Вас сроки.

На всех этапах разработки и производства наши партнеры могут получить квалифицированную поддержку опытных инженеров.

Система менеджмента качества компании отвечает требованиям в соответствии с ГОСТ Р ИСО 9001, ГОСТ РВ 0015-002 и ЭС РД 009

Офис по работе с юридическими лицами:

105318, г.Москва, ул.Щербаковская д.3, офис 1107, 1118, ДЦ «Щербаковский»

Телефон: +7 495 668-12-70 (многоканальный)

Факс: +7 495 668-12-70 (доб.304)

E-mail: info@moschip.ru

Skype отдела продаж:

moschip.ru

moschip.ru_4

moschip.ru_6

moschip.ru_9