

FEATURES

- Contains four 89HP0508P Repeaters that compensates for PCB trace attenuation and ISI jitter
- 16-lane PCIe adapter card with full PCIe protocol support
- Configurable via USB or I²C interfaces using IDT Windows GUI
- EEPROM supports automatic download of configuration data to all four P0508P repeaters
- Enables individual channel configurations of ten parameters including: receiver equalization and threshold voltage, transmit swing and de-emphasis, etc.
- LEDs indicate active lanes
- Switches allow disabling individual lanes
- Multiple power connection options
- Card format: 7.5" x 4.75", non-standard size. Use requires an open chassis
- Works with passive trace cards to extend FR4 traces, also available from IDT (6", 12", 24").

Benefits

- Quick, convenient evaluation of IDT's 89HP0508P repeater operation
- Extends trace length by increasing signal eye opening in terms of voltage and timing margins
- Minimizes BER, improving system performance and reliability
- Can speed design time and reduce risk by eliminating signal integrity issues

Kit Contents

- 1- 89HP0508P 16-lane, PCIe 2.1 Repeater Evaluation Board
- 1- CD with Windows GUI software and design documentation
- 1- 89HP0508P Evaluation Board User's Guide document
- Order Number: 89KTP0508P

System Requirements

- PC or Server with x16-lane PCIe slot
- Desktop or notebook PC with Windows NT, Win7 or Vista to use IDT configuration GUI
- USB cable to connect PC for GUI
- Target add-in cards for system tests

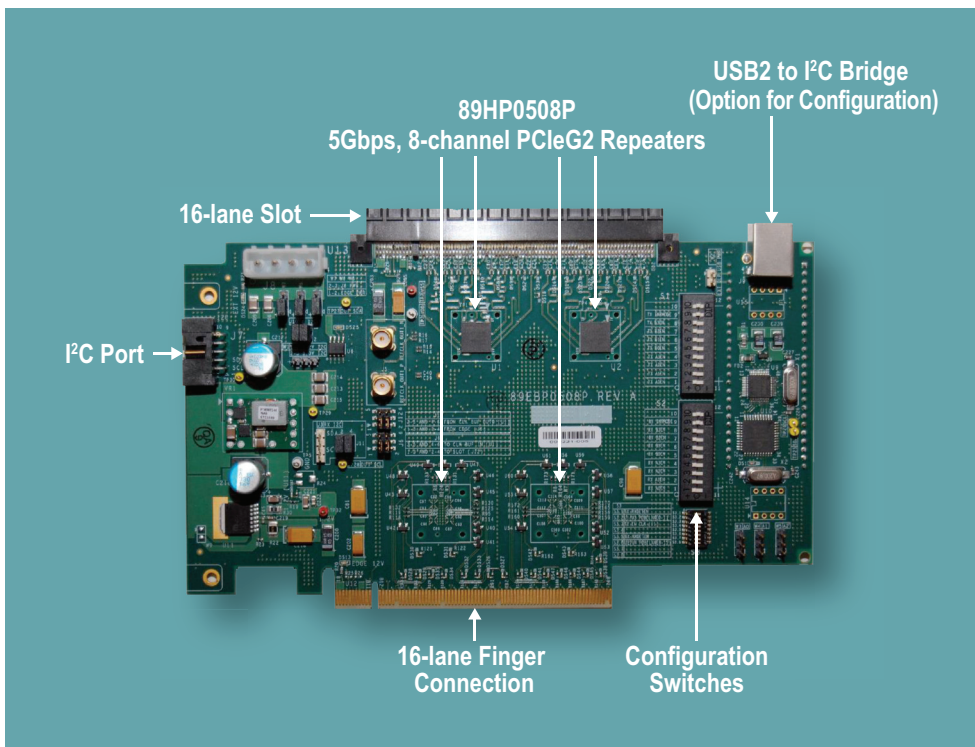

Device Overview

The 89HP0508P Repeater Evaluation Board is designed to enable quick in-system testing of IDT's 8-channel, 5Gbps, PCIe 2.1 Repeater IC product.

The Board features a full 16-lane connection from host through the repeater to an end-point device installed in the PCIe slot. Any width adapter card, from a 1-lane SATA card to a 16-lane graphics accelerator, can be plugged into the top-edge PCIe slot. There is a USB to I²C bridge circuit which allows convenient connection to a PC for accessing the Repeaters via IDT's Repeater Configuration Utility (GUI). An I²C connection is also provided for the same control capability when using an external USB to I²C adapter and IDT's Repeater GUI. The receiver, transmitter, and other device configuration parameters can be adjusted to provide optimum operating margins by using the GUI.

The Eval Board is used by inserting it into a desktop PC or server, and then plugging an end point card (SATA, Ethernet, USB3, etc.) into the 16-lane slot on top, as shown in the example diagram and photo on the following page. Passive trace cards can be used to extend the data signal to emulate a planned system design. Note that the resulting card stack will require an open chassis test environment. IDT's Technical Applications Support team can provide configuration information for different channel lengths and system architectures.



Example Use

This simple example shows the 89HP0508P Evaluation Board used to extend 5Gbps signals across a 24-inch passive trace card to a USB3 controller and over another 12-inch extender card between the host system.

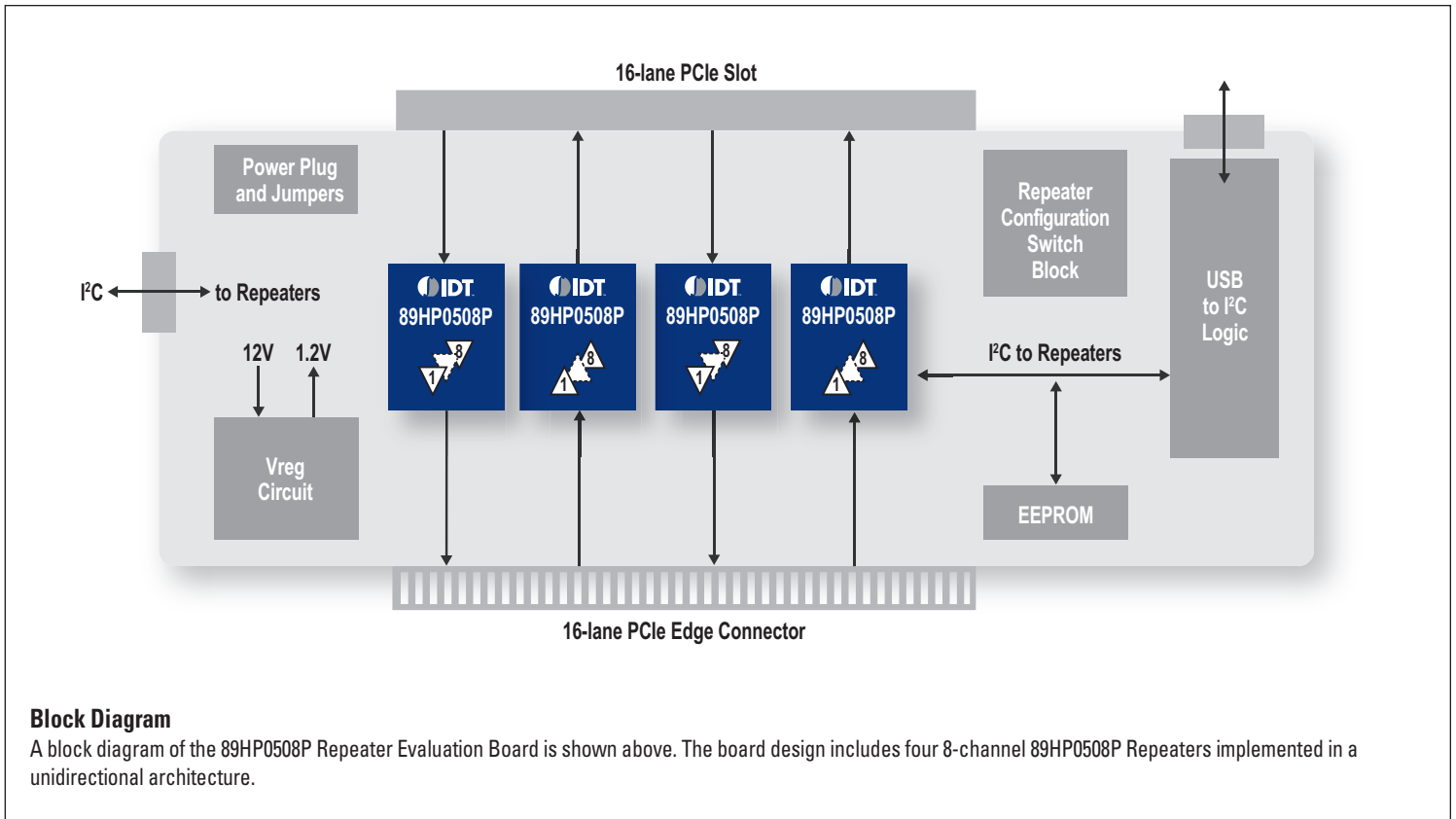
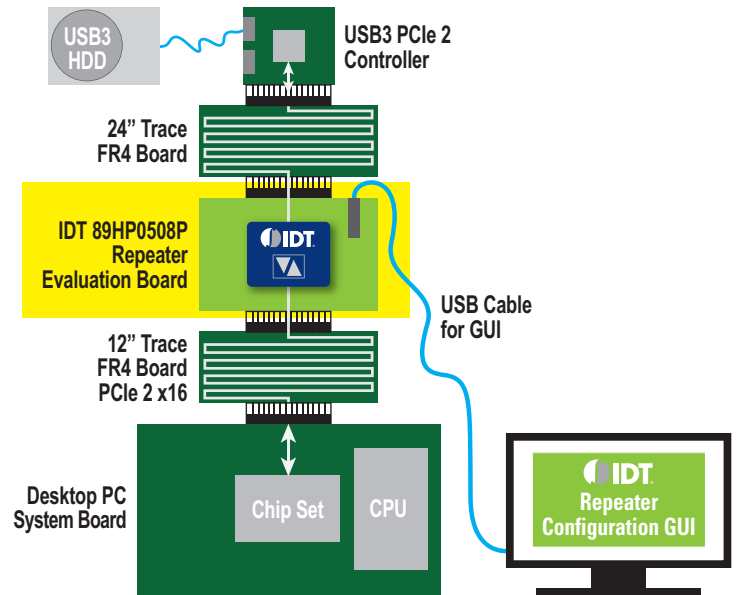

Block Diagram

A block diagram of the 89HP0508P Repeater Evaluation Board is shown above. The board design includes four 8-channel 89HP0508P Repeaters implemented in a unidirectional architecture.

Discover what IDT know-how can do for you: www.IDT.com/go/SIP

DISCLAIMER Integrated Device Technology, Inc. (IDT) and its subsidiaries reserve the right to modify the products and/or specifications described herein at any time and at IDT's sole discretion. All information in this document, including descriptions of product features and performance, is subject to change without notice. Performance specifications and the operating parameters of the described products are determined in the independent state and are not guaranteed to perform the same way when installed in customer products. The information contained herein is provided without representation or warranty of any kind, whether express or implied, including, but not limited to, the suitability of IDT's products for any particular purpose, an implied warranty of merchantability, or non-infringement of the intellectual property rights of others. This document is presented only as a guide and does not convey any license under intellectual property rights of IDT or any third parties. IDT's products are not intended for use in life support systems or similar devices where the failure or malfunction of an IDT product can be reasonably expected to significantly affect the health or safety of users. Anyone using an IDT product in such a manner does so at their own risk, absent an express, written agreement by IDT.

Integrated Device Technology, IDT and the IDT logo are registered trademarks of IDT. Other trademarks and service marks used herein, including protected names, logos and designs, are the property of IDT or their respective third party owners. © Copyright 2011. All rights reserved.

Данный компонент на территории Российской Федерации

Вы можете приобрести в компании MosChip.

Для оперативного оформления запроса Вам необходимо перейти по данной ссылке:

<http://moschip.ru/get-element>

Вы можете разместить у нас заказ для любого Вашего проекта, будь то серийное производство или разработка единичного прибора.

В нашем ассортименте представлены ведущие мировые производители активных и пассивных электронных компонентов.

Нашей специализацией является поставка электронной компонентной базы двойного назначения, продукции таких производителей как XILINX, Intel (ex.ALTERA), Vicor, Microchip, Texas Instruments, Analog Devices, Mini-Circuits, Amphenol, Glenair.

Сотрудничество с глобальными дистрибьюторами электронных компонентов, предоставляет возможность заказывать и получать с международных складов практически любой перечень компонентов в оптимальные для Вас сроки.

На всех этапах разработки и производства наши партнеры могут получить квалифицированную поддержку опытных инженеров.

Система менеджмента качества компании отвечает требованиям в соответствии с ГОСТ Р ИСО 9001, ГОСТ РВ 0015-002 и ЭС РД 009

Офис по работе с юридическими лицами:

105318, г.Москва, ул.Щербаковская д.3, офис 1107, 1118, ДЦ «Щербаковский»

Телефон: +7 495 668-12-70 (многоканальный)

Факс: +7 495 668-12-70 (доб.304)

E-mail: info@moschip.ru

Skype отдела продаж:

moschip.ru

moschip.ru_4

moschip.ru_6

moschip.ru_9