



11.5 Gbps 16 × 16 Crosspoint Switch

Vitesse's multichannel 11.5 Gbps crosspoint switch provides a cost-effective solution for high-speed copper interconnects

Highlights

- DC to 11.5 Gbps operation
- 16 × 16 fully non-blocking switch capability
- Protocol-transparent operation
- Advanced EQ

Applications

- Blade servers
- Storage servers
- Telecom
- Video distribution
- Test and Measurement equipment

The VSC3316 is the industry's highest performance signal integrity crosspoint solution. The VSC3316 is uniquely capable of addressing a wide array of routing, switching, and signal integrity issues across storage, blade server, video distribution, telecommunications, and Ethernet applications. Featuring a 16 × 16 non-blocking, multicasting switch core with ports running at any rate up to 11.5 Gbps, the VSC3316 architecture provides protocol-transparent operation, allowing each channel to run independently. The VSC3316 supports a wide frequency range and virtually all data protocols.

The VSC3316 incorporates Vitesse's fourth-generation input equalization and pre-emphasis I/O capability for the industry's highest speed and protocol requirements. The device can perform signal fanout, loopback, and protection switching. It can also regenerate signals severely compromised by transmission losses. Vitesse's equalization works independently of the data rate, providing highly effective compensation for deterministic jitter across a wide range of high-speed interconnect applications.

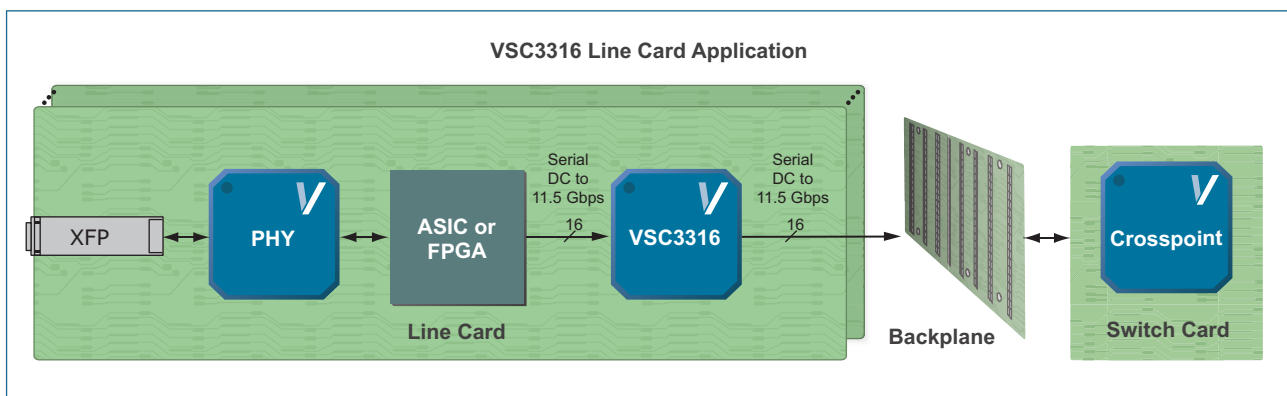

Using the VSC3316 in high-speed line cards ensures best-in-class I/O performance up to 11.5 Gbps with EQ technology to compensate for connector, backplane, and FR-4 loss.

Speed and Protocol Support

- 11.5 Gbps non-return-to-zero (NRZ) data bandwidth
- Protocol-transparent

Architecture

- Fully non-blocking and multicasting switch core
- LOS detection and forwarding (supports out-of-band signaling)
- Fully asynchronous operation with <1 ns latency
- 16 × 16 switch core enables signal fanout, loopback, and protection switching

Signal Integrity

- Multiple time-constant programmable input and output equalization
- Wide equalization adjustment range
- Input EQ of 26 dB at 11.5 Gbps
- 9 dB of pre-emphasis
- Embedded post-EQ eye opening monitor per channel

Key Specifications

- 11.5 Gbps NRZ per channel data rate
- 2.5 V power supply
- 15 mm × 15 mm flip chip ball grid array package

Related Vitesse Products

Visit www.vitesse.com for information about these related Vitesse products:

- Crosspoint Switches
- Ethernet MACs
- Mux, Demux, and Transceivers
- Electronic Dispersion Compensation CDRs

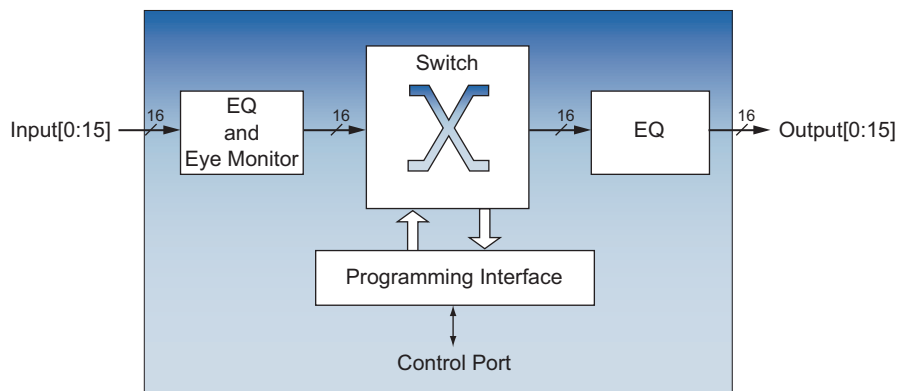

Vitesse Semiconductor Corporation

741 Calle Plano • Camarillo, CA 93012 USA • Tel: +1.800.VITESSE • +1.805.388.3700 • Fax: +1.805.987.5896 • www.vitesse.com

© 2008–2010 by Vitesse Semiconductor Corporation. VPPD-02111 Revision 1.2. Vitesse Semiconductor Corporation ("Vitesse") retains the right to make changes to its products or specifications. As such, all information in this document, including descriptions of features, functions, performance, technical specifications and availability, is subject to change without notice at any time, and Vitesse assumes no responsibility for use of any information herein. Nothing contained herein conveys to the purchaser of microelectronic devices any license under the patent or any other intellectual property rights of any manufacturer. Vitesse®, and numerous other trademarks, are trademarks of Vitesse in the United States and/or other jurisdictions. Other trademarks used herein that are not the property of Vitesse are the property of their respective owners. While Vitesse products support IEC 60825, use of Vitesse products does not ensure compliance to IEC 60825. Buyers are responsible for ensuring compliance to IEC 60825. Buyers must fully indemnify Vitesse for any damages resulting from non-compliance to IEC 60825.

Данный компонент на территории Российской Федерации

Вы можете приобрести в компании MosChip.

Для оперативного оформления запроса Вам необходимо перейти по данной ссылке:

<http://moschip.ru/get-element>

Вы можете разместить у нас заказ для любого Вашего проекта, будь то серийное производство или разработка единичного прибора.

В нашем ассортименте представлены ведущие мировые производители активных и пассивных электронных компонентов.

Нашей специализацией является поставка электронной компонентной базы двойного назначения, продукции таких производителей как XILINX, Intel (ex.ALTERA), Vicor, Microchip, Texas Instruments, Analog Devices, Mini-Circuits, Amphenol, Glenair.

Сотрудничество с глобальными дистрибьюторами электронных компонентов, предоставляет возможность заказывать и получать с международных складов практически любой перечень компонентов в оптимальные для Вас сроки.

На всех этапах разработки и производства наши партнеры могут получить квалифицированную поддержку опытных инженеров.

Система менеджмента качества компании отвечает требованиям в соответствии с ГОСТ Р ИСО 9001, ГОСТ РВ 0015-002 и ЭС РД 009

Офис по работе с юридическими лицами:

105318, г.Москва, ул.Щербаковская д.3, офис 1107, 1118, ДЦ «Щербаковский»

Телефон: +7 495 668-12-70 (многоканальный)

Факс: +7 495 668-12-70 (доб.304)

E-mail: info@moschip.ru

Skype отдела продаж:

moschip.ru

moschip.ru_4

moschip.ru_6

moschip.ru_9