

24-bit 192kHz Stereo DAC with 1.7Vrms Line Driver

DESCRIPTION

The WM8501 is a high performance stereo DAC with an integrated 1.7Vrms line driver. It is designed for audio applications that require a high voltage output along with enhanced load drive capability.

The WM8501 supports data input word lengths from 16 to 24-bits and sampling rates up to 192kHz. The WM8501 consists of a serial interface port, digital interpolation filters, multi-bit sigma delta modulators and stereo DAC in a 14-lead SOIC package.

The hardware control interface is used for the selection of audio data interface format, enable and de-emphasis. The WM8501 supports I²S, right Justified or DSP interfaces.

Operating on separate analog and digital supplies the WM8501 offers very lower power consumption from the digital section, whilst supporting enhanced load drive from the analogue output.

FEATURES

- Stereo DAC with 1.7Vrms line driver from 5V analogue supply
- Audio performance
 - 100dB SNR ('A' weighted @ 48kHz)
 - -88dB THD
- DAC Sampling Frequency: 8kHz – 192kHz
- Pin Selectable Audio Data Interface Format
 - I²S, 16-bit Right Justified or DSP
- 14-lead SOIC package
- 4.5V - 5.5V analogue, 2.7V - 5.5V digital supply operation

APPLICATIONS

- STB
- DVD
- Digital TV

BLOCK DIAGRAM

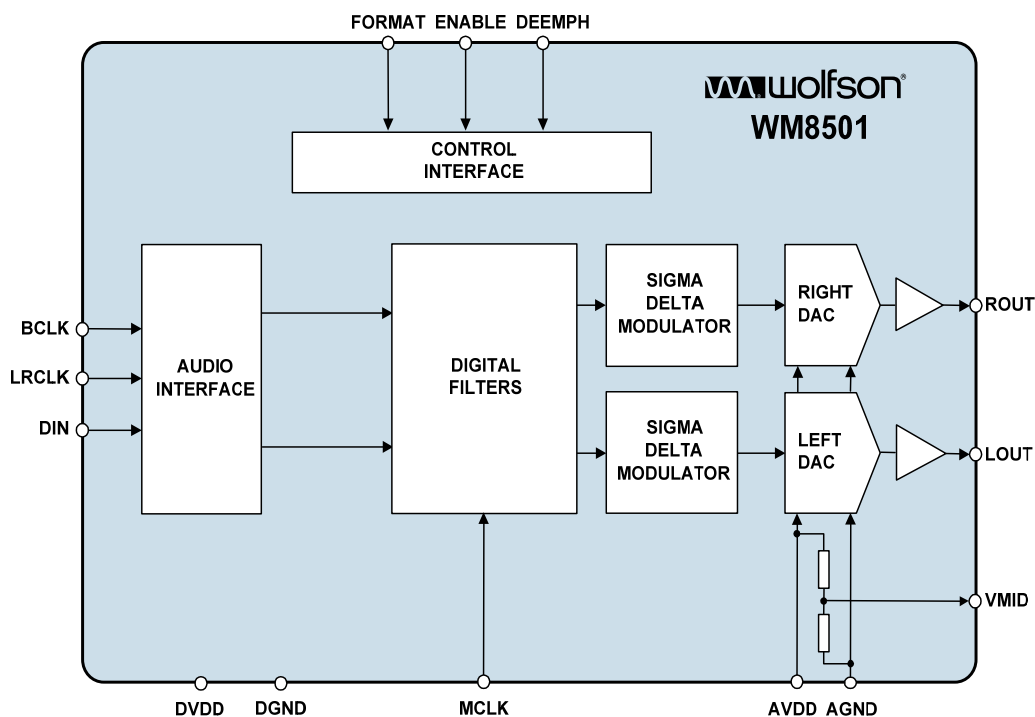
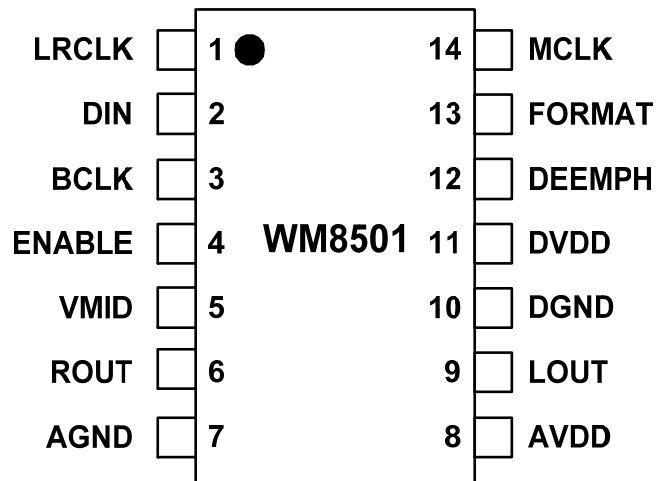

TABLE OF CONTENTS

DESCRIPTION	1
FEATURES	1
APPLICATIONS	1
BLOCK DIAGRAM	1
TABLE OF CONTENTS	2
PIN CONFIGURATION	3
ORDERING INFORMATION	3
PIN DESCRIPTION	4
ABSOLUTE MAXIMUM RATINGS	5
RECOMMENDED OPERATING CONDITIONS	5
ELECTRICAL CHARACTERISTICS	6
MASTER CLOCK TIMING	7
DIGITAL AUDIO INTERFACE	7
DEVICE DESCRIPTION	9
GENERAL INTRODUCTION	9
DAC CIRCUIT DESCRIPTION	9
CLOCKING SCHEMES	10
DIGITAL AUDIO INTERFACE	10
AUDIO DATA SAMPLING RATES	12
HARDWARE CONTROL MODES	12
DIGITAL FILTER CHARACTERISTICS	14
DAC FILTER RESPONSES	14
DIGITAL DE-EMPHASIS CHARACTERISTICS	15
APPLICATIONS INFORMATION	16
RECOMMENDED EXTERNAL COMPONENTS	16
POWER UP/DOWN SEQUENCE	17
RECOMMENDED ANALOGUE LOW PASS FILTER.....	17
PCB LAYOUT RECOMMENDATIONS.....	18
PACKAGE DRAWING	19
IMPORTANT NOTICE	20
ADDRESS:	20

PIN CONFIGURATION



ORDERING INFORMATION

DEVICE	TEMPERATURE RANGE	PACKAGE	MOISTURE SENSITIVITY LEVEL	PEAK SOLDERING TEMPERATURE
WM8501CGED	-40 to +85°C	14-lead SOIC (Pb-free)	MSL1	260°C
WM8501CGED/R	-40 to +85°C	14-lead SOIC (Pb-free, tape and reel)	MSL1	260°C

Note:

Reel quantity = 3,000

PIN DESCRIPTION

PIN	NAME	TYPE	DESCRIPTION
1	LRCLK	Digital input	Sample rate clock input
2	DIN	Digital input	Serial audio data input
3	BCLK	Digital input	Bit clock input
4	ENABLE	Digital input	Enable input – 0 = powered down, 1 = enabled
5	VMID	Analogue output	Analogue internal reference
6	ROUT	Analogue output	Right channel DAC output
7	AGND	Supply	Ground reference for analog circuits and substrate connection
8	AVDD	Supply	Positive supply for analog circuits
9	LOUT	Analogue output	Left channel DAC output
10	DGND	Digital Supply	Digital ground supply
11	DVDD	Digital Supply	Digital positive supply
12	DEEMPH	Digital input	De-emphasis select, Internal pull down High = de-emphasis ON Low = de-emphasis OFF
13	FORMAT	Digital input	Data input format select, Internal pull up Low = 16-bit right justified or DSP (Mode B) High = 16-24-bit I ² S or DSP (Mode A)
14	MCLK	Digital input	Master clock input

Note:

1. Digital input pins have Schmitt trigger input buffers.

ABSOLUTE MAXIMUM RATINGS

Absolute Maximum Ratings are stress ratings only. Permanent damage to the device may be caused by continuously operating at or beyond these limits. Device functional operating limits and guaranteed performance specifications are given under Electrical Characteristics at the test conditions specified.



ESD Sensitive Device. This device is manufactured on a CMOS process. It is therefore generically susceptible to damage from excessive static voltages. Proper ESD precautions must be taken during handling and storage of this device.

Wolfson tests its package types according to IPC/JEDEC J-STD-020 for Moisture Sensitivity to determine acceptable storage conditions prior to surface mount assembly. These levels are:

MSL1 = unlimited floor life at <30°C / 85% Relative Humidity. Not normally stored in moisture barrier bag.

MSL2 = out of bag storage for 1 year at <30°C / 60% Relative Humidity. Supplied in moisture barrier bag.

MSL3 = out of bag storage for 168 hours at <30°C / 60% Relative Humidity. Supplied in moisture barrier bag.

The Moisture Sensitivity Level for each package type is specified in Ordering Information.

CONDITION	MIN	MAX
Analogue supply voltage	-0.3V	+7V
Digital supply voltage	-0.3V	+7V
Voltage range digital inputs	DGND -0.3V	DVDD +0.3V
Master clock frequency		38.462MHz
Operating temperature range, T _A	-40°C	+85°C
Storage temperature prior to soldering	30°C max / 85% RH max	
Storage temperature after soldering	-65°C	+150°C

RECOMMENDED OPERATING CONDITIONS

PARAMETER	SYMBOL	TEST CONDITIONS	MIN	TYP	MAX	UNIT
Digital supply range	DVDD		2.7		5.5	V
Analogue supply range	AVDD		4.5		5.5	V
Ground	AGND, DGND			0		V
Difference DGND to AGND			-0.3	0	+0.3	V

Note: Digital supply DVDD must never be more than 0.3V greater than AVDD for normal operation of the device.

ELECTRICAL CHARACTERISTICS

Test Conditions

AVDD = 5V, DVDD = 3.3V, GND = 0V, T_A = +25°C, fs = 48kHz, MCLK = 256fs unless otherwise stated.

PARAMETER	SYMBOL	TEST CONDITIONS	MIN	TYP	MAX	UNIT
Digital Logic Levels (TTL Levels)						
Input LOW level	V _{IL}				0.8	V
Input HIGH level	V _{IH}		2.0			V
Output LOW	V _{OL}	I _{OL} = 2mA			DGND + 0.3V	V
Output HIGH	V _{OH}	I _{OH} = 2mA	DVDD – 0.3V			V
Analogue Reference Levels						
Reference voltage (VMID)				AVDD/2		V
Potential divider resistance	R _{CAP}	AVDD to VMID and VMID to GND		50		kΩ
DAC Output (Load = 10kΩ, 50pF)						
0dBFS Full scale output voltage		At DAC outputs	1.6 x AVDD/5	1.7 x AVDD/5	1.8 x AVDD/5	V _{rms}
Signal to Noise Ratio (Note 5,6,7)	SNR	A-weighted, @ fs = 48kHz	90	100		dB
		A-weighted @ fs = 96kHz		97		dB
		A-weighted @ fs = 192kHz		97		dB
Dynamic Range (Note 2, 6)	DNR	A-weighted, -60dB full scale input	90	100		dB
Total Harmonic Distortion (Note 7)	THD	1kHz, Load = 10kΩ, 0dBFS		-88	-78	dB
DAC channel separation				93		dB
Analogue Output Levels						
Output level (line output)		Load = 10kΩ, 0dBFS		1.7		V _{rms}
Minimum resistance load (line output)		To midrail or a.c. coupled		820		Ω
Output level (Headphone output)		Load = 16Ω, 0dBFS		1.0		V _{rms}
Minimum resistance load (Headphone output)		To midrail or a.c. coupled		16		Ω
Gain mismatch channel-to-channel				±1		%FSR
Output d.c. level				AVDD/2		V
Supply Current						
Analogue supply current		AVDD = 5V		9		mA
Digital supply current		DVDD = 5V		8		mA
		DVDD = 3.3V		4.5		mA
Power down current (note 4)		AVDD=DVDD=5V		0.01		mA

Notes:

- Ratio of output level with 1kHz full scale input, to the output level with all zeros into the digital input, measured 'A' weighted over a 20Hz to 20kHz bandwidth.
- All performance measurements done with 20kHz low pass filter, and where noted an A-weight filter. Failure to use such a filter will result in higher THD and lower SNR and Dynamic Range readings than are found in the Electrical Characteristics. The low pass filter removes out of band noise; although it is not audible it may affect dynamic specification values.
- VMID pin decoupled with 10uF and 0.1uF capacitors (smaller values may result in reduced performance).
- Power down occurs 1.5μs after MCLK is stopped.
- Signal-to-noise ratio (dB) – SNR is a measure of the difference in level between the full scale output and the output with no signal applied. (No Auto-zero or Automute function is employed in achieving these results).

6. Dynamic range (dB) – DNR is a measure of the difference between the highest and lowest portions of a signal. Normally a THD measurement at 60dB below full scale. The measured signal is then corrected by adding the 60dB to it. (e.g. THD @ -60dB= -32dB, DR= 92dB).
7. THD (dB) – THD is a ratio, of the rms values, of Distortion/Signal.
8. Stop band attenuation (dB) – Is the degree to which the frequency spectrum is attenuated (outside audio band).
9. Channel Separation (dB) – Also known as Cross-Talk. This is a measure of the amount one channel is isolated from the other. Normally measured by sending a full scale signal down one channel and measuring the other.

MASTER CLOCK TIMING

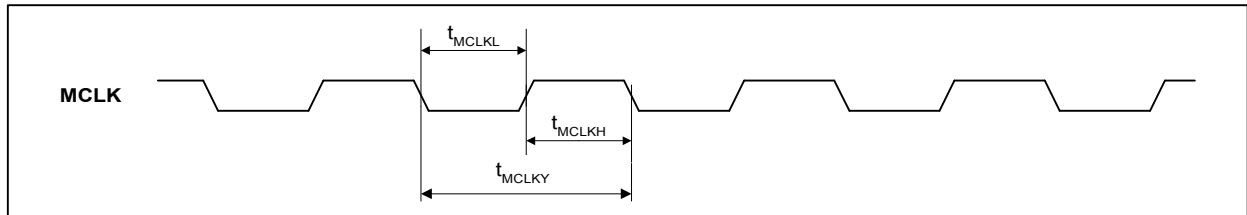

Figure 1 Master Clock Timing Requirements

Test Conditions

VDD = 5V, GND = 0V, $T_A = +25^{\circ}C$, $f_s = 48kHz$, MCLK = 256fs unless otherwise stated.

PARAMETER	SYMBOL	TEST CONDITIONS	MIN	TYP	MAX	UNIT
System Clock Timing Information						
MCLK Master clock pulse width high	t_{MCLKH}		8			ns
MCLK Master clock pulse width low	t_{MCLKL}		8			ns
MCLK Master clock cycle time	t_{MCLKY}		20			ns
MCLK Duty cycle			40:60		60:40	
Time from MCLK stopping to power down.			1.5		12	μs

DIGITAL AUDIO INTERFACE

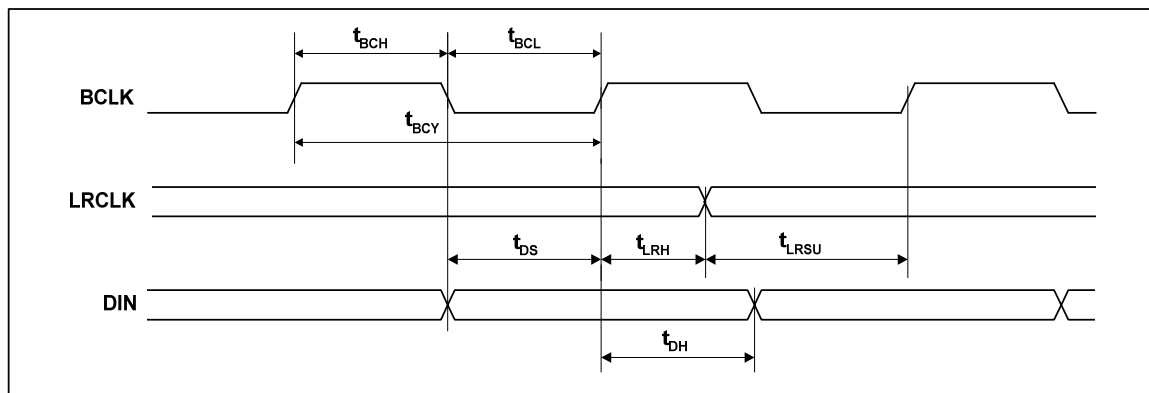

Figure 2 Digital Audio Data Timing

Test Conditions

VDD = 5V, GND = 0V, T_A = +25°C, fs = 48kHz, MCLK = 256fs unless otherwise stated.

PARAMETER	SYMBOL	TEST CONDITIONS	MIN	TYP	MAX	UNIT
Audio Data Input Timing Information						
BCLK cycle time	t _{BCY}		40			ns
BCLK pulse width high	t _{BCH}		16			ns
BCLK pulse width low	t _{BCL}		16			ns
LRCLK set-up time to BCLK rising edge	t _{LRSU}		8			ns
LRCLK hold time from BCLK rising edge	t _{LRH}		8			ns
DIN set-up time to BCLK rising edge	t _{DS}		8			ns
DIN hold time from BCLK rising edge	t _{DH}		8			ns

DEVICE DESCRIPTION

GENERAL INTRODUCTION

The WM8501 is a high performance DAC with an integrated 1.7Vrms line driver from a 5V analogue supply, designed for digital consumer audio applications.

The WM8501 is a complete 2-channel stereo audio digital-to-analogue converter, including digital interpolation filter, multi-bit sigma delta with dither, and switched capacitor multi-bit stereo DAC and output smoothing filters. It is fully compatible and an ideal partner for a range of industry standard microprocessors, controllers and DSPs. Control of the internal functionality of the device is provided by hardware control pins (pin programmed).

Operation using master clocks of 256fs, 384fs, 512fs or 768fs is supported, selection between clock rates being automatically controlled. Sample rates (fs) from less than 8kHz to 96kHz are allowed, provided the appropriate system clock is input. Support is also provided for up to 192kHz using a master clock of 128fs or 192fs.

The audio data interface supports 16-bit right justified or 16-24-bit I²S (Philips left justified, one bit delayed) interface formats. A DSP interface is also supported, enhancing the interface options for the user.

Split analog and digital 2.7-5.5V supply may be used, the output amplitude scaling with absolute analogue supply level. Low supply voltage operation and low current consumption combined with the low pin count small package make the WM8501 attractive for many consumer applications. A power down mode is provided, allowing power consumption to be minimised.

The device is packaged in a small 14-pin SOIC.

DAC CIRCUIT DESCRIPTION

The WM8501 DAC is designed to allow playback of 24-bit PCM audio or similar data with high resolution and low noise and distortion. Sample rates up to 192kHz may be used, with much lower sample rates being acceptable provided that the ratio of sample rate (LRCLK) to master clock (MCLK) is maintained at one of the required rates.

The two DACs on the WM8501 are implemented using sigma-delta oversampled conversion techniques. These require that the PCM samples are digitally filtered and interpolated to generate a set of samples at a much higher rate than the up to 192kHz input rate. This sample stream is then digitally modulated to generate a digital pulse stream that is then converted to analogue signals in a switched capacitor DAC.

The advantage of this technique is that the DAC is linearised using noise shaping techniques, allowing the 24-bit resolution to be met using non-critical analogue components. A further advantage is that the high sample rate at the DAC output means that smoothing filters on the output of the DAC need only have fairly crude characteristics in order to remove the characteristic steps, or images on the output of the DAC. To prevent the generation of unwanted tones dithering is used in the digital modulator along with a higher order modulator.

The multi-bit switched capacitor technique used in the DAC reduces sensitivity to clock jitter, and dramatically reduces out of band noise compared to switched current or single bit techniques.

The voltage on the VMID pin is used as the reference for the DACs. Therefore the amplitude of the signals at the DAC outputs will scale with the amplitude of the voltage at the VMID pin. An external reference could be used to drive into the VMID pin if desired, with a value typically of about midrail ideal for optimum performance.

The outputs of the 2 DACs are buffered out of the device by buffer amplifiers capable of driving into low impedance line loads as low as 820Ω or headphone loads down to 16Ω. The buffer amplifier output voltage level is set to 1.7V rms for line level loads when using a 5V analogue supply, avoiding the requirement for additional gain stages or higher voltage supplies in many applications. When driving headphone loads the output voltage level is limited to 1Vrms. The advanced multi-bit DAC used in WM8501 produces far less out of band noise than single bit traditional sigma delta DACs, and so in most applications where a line level output is required, no post DAC filter is required. Typically an AC coupling capacitor and a DC setting resistor to ground are the only components required on the output of the chip.

CLOCKING SCHEMES

In a typical digital audio system there is only one central clock source producing a reference clock to which all audio data processing is synchronised. This clock is often referred to as the audio system's Master Clock. The external master clock can be applied directly through the MCLK input pin with no configuration necessary for sample rate selection.

Note that on the WM8501, MCLK is used to derive clocks for the DAC path. The DAC path consists of DAC sampling clock, DAC digital filter clock and DAC digital audio interface timing. In a system where there are a number of possible sources for the reference clock it is recommended that the clock source with the lowest jitter be used to optimise the performance of the DAC.

The device can be powered down by stopping MCLK. In this state the power consumption is substantially reduced.

DIGITAL AUDIO INTERFACE

Audio data is applied to the internal DAC filters via the Digital Audio Interface. Three interface formats are supported:

- Right Justified mode
- I²S mode
- DSP mode

All formats send the MSB first. The data format is selected with the FORMAT pin. When FORMAT is LOW, right justified data format is selected and word lengths of 16-bits may be used. When the FORMAT pin is HIGH, I²S format is selected and word length of any value up to 24-bits may be used. (If a word length shorter than 24-bits is used, the unused bits should be padded with zeros). If LRCLK is 4 BCLKs or less duration, the DSP compatible format is selected. Mode A and Mode B clock formats are supported, selected by the state of the FORMAT pin.

'Packed' mode (i.e. only 32 or 48 clocks per LRCLK period) operation is also supported in both I²S (16-24 bits) and right justified formats, (16 bit). If a 'packed' format of 16-bit word length is applied (16 BCLKS per LRCLK half period), the device auto-detects this mode and switches to 16-bit data length.

I²S MODE

The WM8501 supports word lengths of 16-24 bits in I²S mode.

In I²S mode, the digital audio interface receives data on the DIN input. Audio Data is time multiplexed with LRCLK indicating whether the left or right channel is present. LRCLK is also used as a timing reference to indicate the beginning or end of the data words.

In I²S modes, the minimum number of BCLKs per LRCLK period is 2 times the selected word length. LRCLK must be high for a minimum of word length BCLKs and low for a minimum of word length BCLKs. Any mark to space ratio on LRCLK is acceptable provided the above requirements are met. In I²S mode, the MSB is sampled on the second rising edge of BCLK following a LRCLK transition. LRCLK is low during the left samples and high during the right samples.

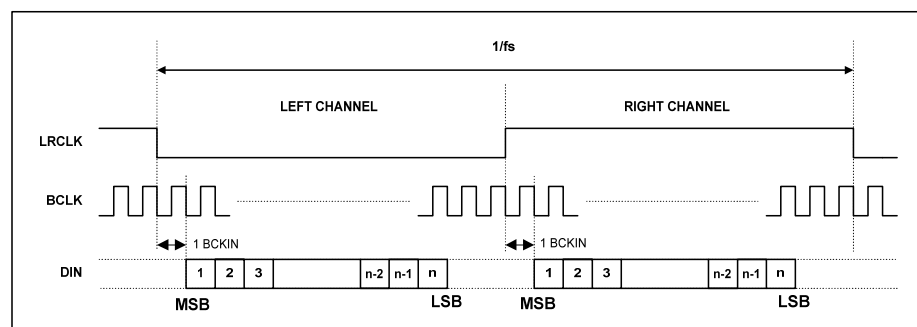

Figure 3 I²S Mode Timing Diagram

RIGHT JUSTIFIED MODE

The WM8501 supports word lengths of 16-bits in right justified mode.

In right justified mode, the digital audio interface receives data on the DIN input. Audio Data is time multiplexed with LRCLK indicating whether the left or right channel is present. LRCLK is also used as a timing reference to indicate the beginning or end of the data words.

In right justified mode, the minimum number of BCLKs per LRCLK period is 2 times the selected word length. LRCLK must be high for a minimum of word length BCLKs and low for a minimum of word length BCLKs. Any mark to space ratio on LRCLK is acceptable provided the above requirements are met.

In right justified mode, the LSB is sampled on the rising edge of BCLK preceding a LRCLK transition. LRCLK is high during the left samples and low during the right samples.

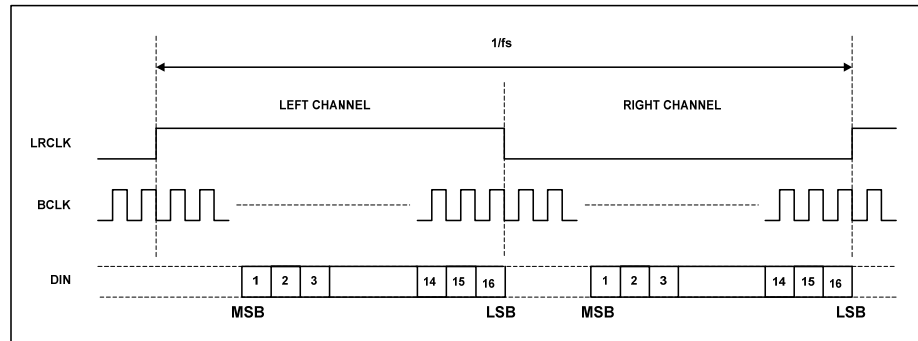

Figure 4 Right Justified Mode Timing Diagram

DSP MODE

A DSP compatible, time division multiplexed format is also supported by the WM8501. This format is of the type where a 'synch' pulse is followed by two data words (left and right) of predetermined word length. (16-bits). The 'synch' pulse replaces the normal duration LRCLK, and DSP mode is auto-detected by the shorter than normal duration of the LRCLK. If LRCLK is of 4 BCLK or less duration, the DSP compatible format is selected. Mode A and Mode B clock formats are supported, selected by the state of the FORMAT pin.

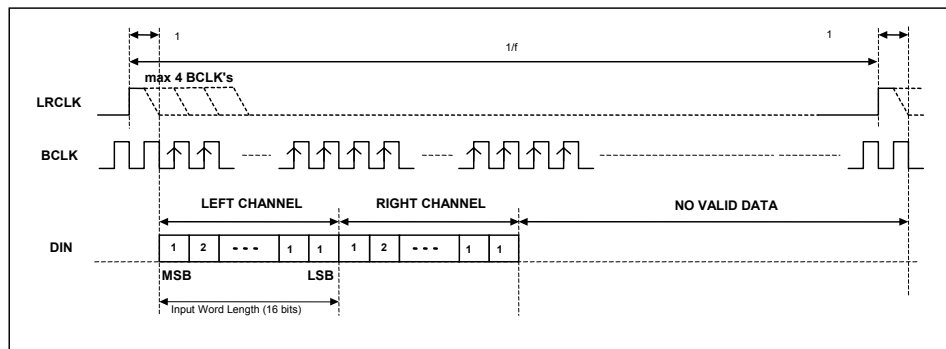

Figure 5 DSP Mode A Timing

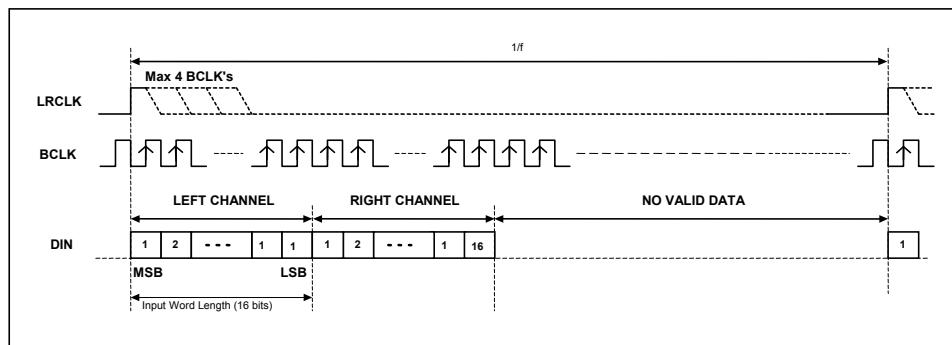

Figure 6 DSP Mode B Timing

AUDIO DATA SAMPLING RATES

The master clock for WM8501 supports audio sampling rates from 128fs to 768fs, where fs is the audio sampling frequency (LRCLK) typically 32kHz, 44.1kHz, 48kHz, 96kHz or 192kHz. The master clock is used to operate the digital filters and the noise shaping circuits.

The WM8501 has a master clock detection circuit that automatically determines the relation between the master clock frequency and the sampling rate (to within +/- 8 master clocks). If there is a greater than 8 clocks error, the interface shuts down the DAC and mutes the output. The master clock should be synchronised with LRCLK, although the WM8501 is tolerant of phase differences or jitter on this clock.

SAMPLING RATE (LRCLK)	MASTER CLOCK FREQUENCY (MHz) (MCLK)					
	128fs	192fs	256fs	384fs	512fs	768fs
32kHz	4.096	6.144	8.192	12.288	16.384	24.576
44.1kHz	5.6448	8.467	11.2896	16.9344	22.5792	33.8688
48kHz	6.144	9.216	12.288	18.432	24.576	36.864
96kHz	12.288	18.432	24.576	36.864	Unavailable	Unavailable
192kHz	24.576	36.864	Unavailable	Unavailable	Unavailable	Unavailable

Table 1 Master Clock Frequencies Versus Sampling Rate

HARDWARE CONTROL MODES

The WM8501 is hardware programmable providing the user with options to select input audio data format, de-emphasis and mute.

ENABLE OPERATION

Pin 4 (ENABLE) controls the operation of the chip. If ENABLE is low the device is held in a low power state. If this pin is held high the device is powered up.

To ensure correct operation it is essential that there is a low to high transition on the ENABLE pin after digital supplies have come on. This can be achieved by providing the ENABLE signal from an external controller chip or by means of a simple RC network on the ENABLE pin. See "Recommended External Components" in the "Application Information" section at the end of this datasheet.

Note that the ENABLE pin should not be used as a mute pin or to temporarily silence the DAC (between tracks of a CD for example). The ENABLE pin is not intended to be used as a mute control but to allow entry into low power mode. Disabling the device via the ENABLE pin has the effect of powering down the voltage on the VMID pin. Repeated enabling/disabling of the device can cause audible pops at the output.

HIGH PERFORMANCE MODE

On the rising edge of ENABLE, the DEEMPH pin is sampled. If it is low the device powers up normally. If it is high the device goes into a high performance and high power consumption state. Once ENABLE is high, DEEMPH controls the selection of the de-emphasis filter.

INPUT AUDIO FORMAT SELECTION

FORMAT (pin 13) controls the data input format.

FORMAT	INPUT DATA MODE
0	16 bit right justified
1	16–24 bit I ² S

Table 2 Input Audio Format Selection

Notes:

1. In 16-24 bit I²S mode, any data from 16-24 bits or more is supported provided that LRCLK is high for a minimum of data width BCLKs and low for a minimum of data width BCLKs, unless Note 2. For data widths greater than 24 bits, the LSB's will be truncated and the most significant 24 bits will be used by the internal processing.
2. If exactly 16 BCLK cycles occur in both the low and high period of LRCLK the WM8501 will assume the data is 16-bit and accept the data accordingly.

INPUT DSP FORMAT SELECTION

FORMAT	50% LRCLK DUTY CYCLE	LRCLK of 4 BCLK or Less Duration
0	16 bit (MSB-first, right justified)	DSP format –mode B
1	I ² S format up to 24 bit (Philips serial data protocol)	DSP format –mode A

Table 3 DSP Interface Formats

DE-EMPHASIS CONTROL

DEEMPH (pin 12) is an input control for selection of de-emphasis filtering to be applied.

DEEMPH	DE-EMPHASIS
0	Off
1	On

Table 4 De-emphasis Control

DIGITAL FILTER CHARACTERISTICS

PARAMETER	SYMBOL	TEST CONDITIONS	MIN	TYP	MAX	UNIT
Passband Edge		-3dB		0.487fs		
Passband Ripple		$f < 0.444fs$			± 0.05	dB
Stopband Attenuation		$f > 0.555fs$	-60			dB

Table 5 Digital Filter Characteristics

DAC FILTER RESPONSES

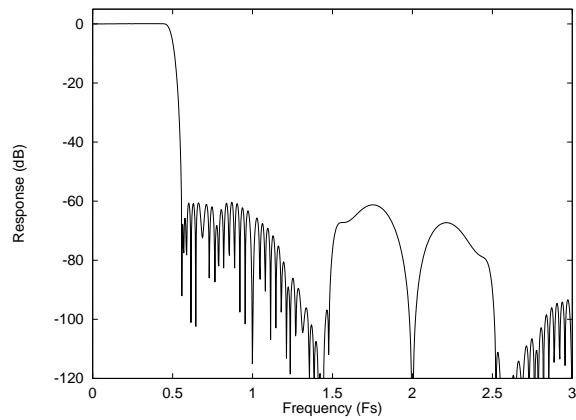

Figure 7 DAC Digital Filter Frequency Response - 44.1, 48 and 96kHz

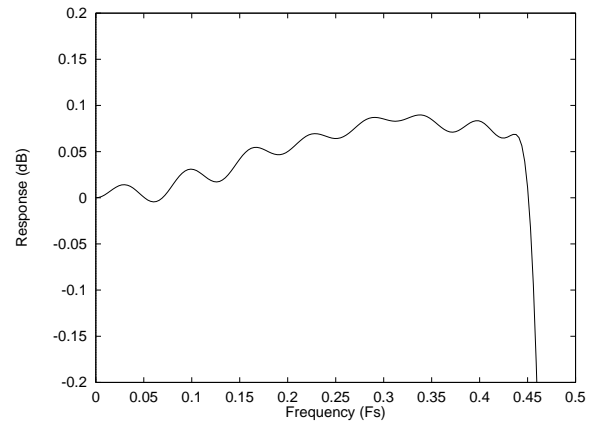

Figure 8 DAC Digital Filter Ripple - 44.1, 48 and 96kHz

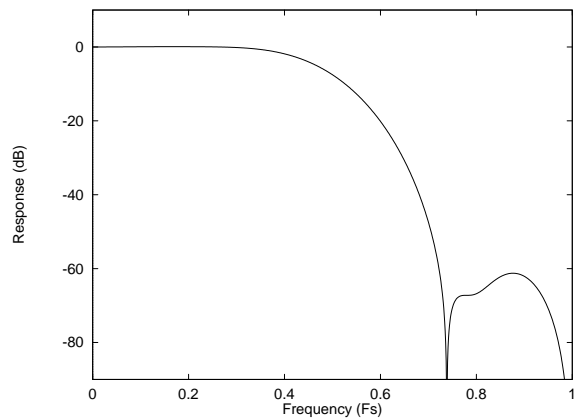

Figure 9 DAC Digital Filter Frequency Response - 192kHz

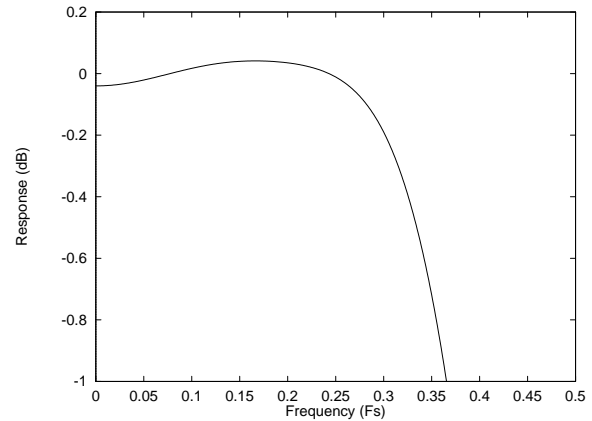

Figure 10 DAC Digital Filter Ripple - 192kHz

DIGITAL DE-EMPHASIS CHARACTERISTICS

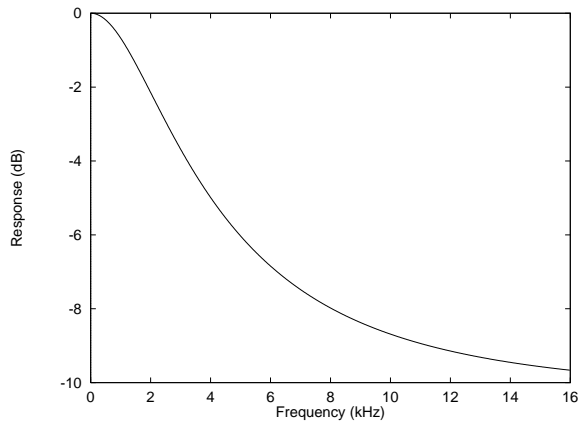

Figure 11 De-Emphasis Frequency Response (32kHz)

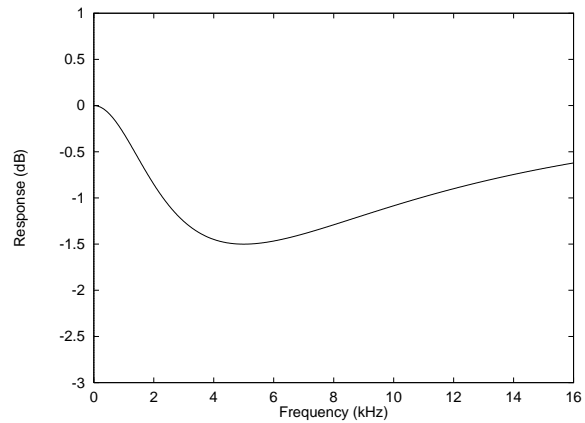

Figure 12 De-Emphasis Error (32kHz)

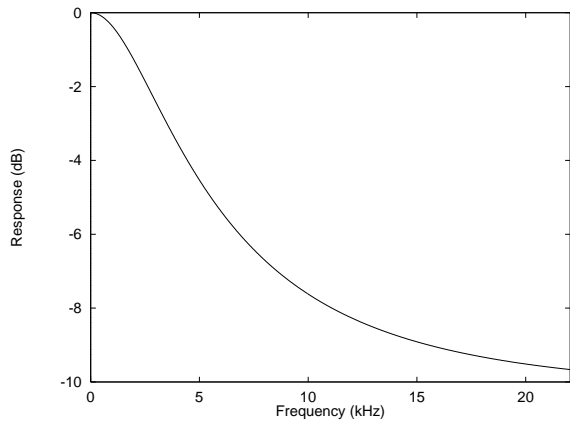

Figure 13 De-Emphasis Frequency Response (44.1kHz)

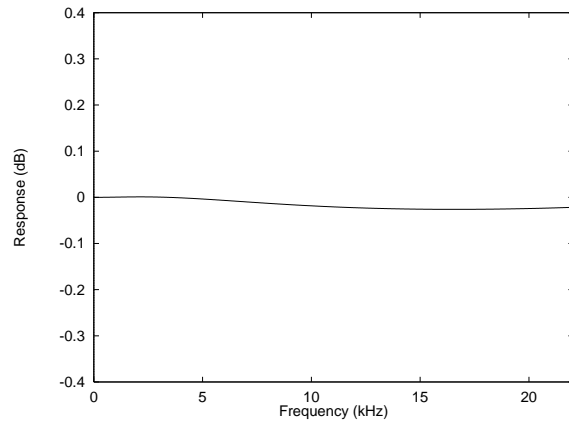

Figure 14 De-Emphasis Error (44.1kHz)

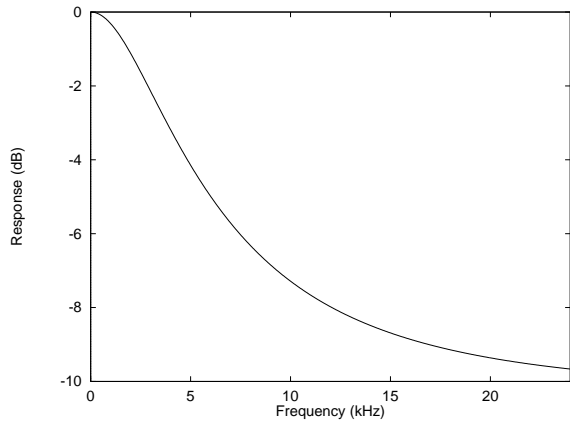

Figure 15 De-Emphasis Frequency Response (48kHz)

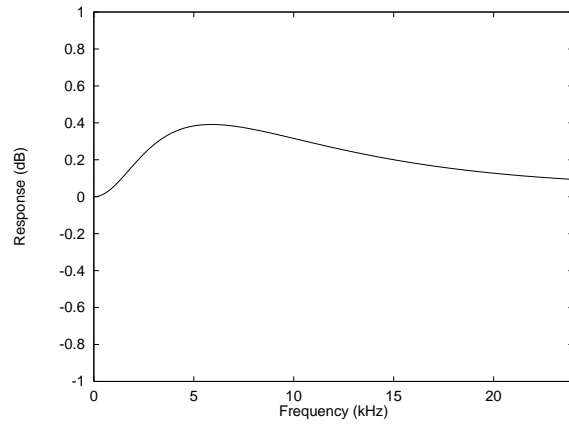

Figure 16 De-Emphasis Error (48kHz)

APPLICATIONS INFORMATION

RECOMMENDED EXTERNAL COMPONENTS

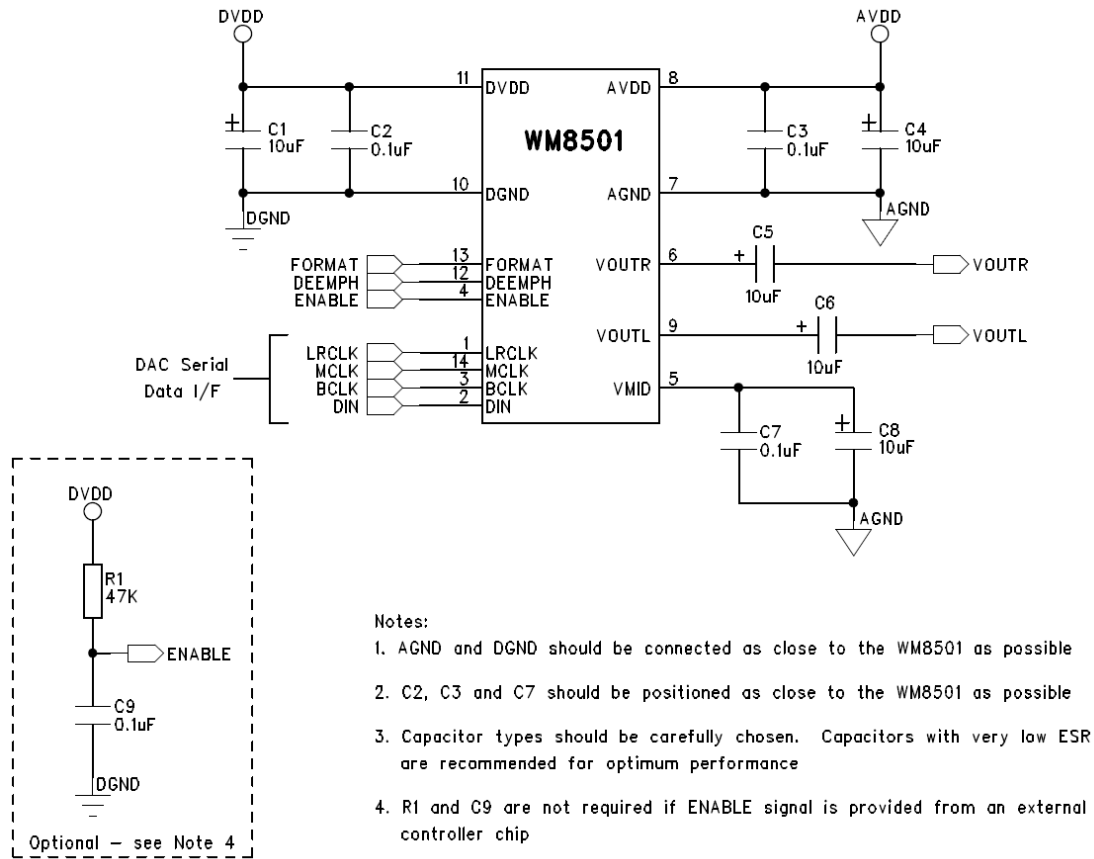

Figure 17 External Component Diagram

In an application where ENABLE is fed directly from VDD rather than a dedicated control line, resistor R3 and capacitor C9 are used on the ENABLE pin to introduce a short delay in the Low to High transition of ENABLE. This will ensure the pin goes high after power supplies have had time to settle (see “ENABLE Operation” in the “Hardware Control Modes” section of the datasheet).

However, if the ENABLE signal is being provided from an external controller chip rather than VDD directly, R3 and C9 will not be required.

POWER UP/DOWN SEQUENCE

POWER UP/DOWN SEQUENCE

For click free operation, the WM8501 should be powered up and down in a specific sequence.

Power-up:

1. Power up AVDD and DVDD and wait to settle
2. Turn on clocks and data (MCLK, BCLK, LRCLK, SDATA)
3. Switch ENABLE pin from low to high

Power-down:

1. Switch Enable from high to low
2. Remove clocks and data
3. Power down AVDD and DVDD

RECOMMENDED ANALOGUE LOW PASS FILTER

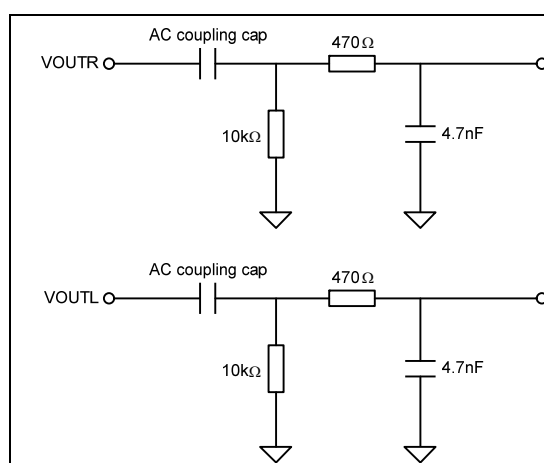

Figure 18 Recommended 1st Order Low Pass Filter

Note: Capacitors should be COG dielectric.

An external single pole RC filter is recommended (see Figure 18) if the device is driving a wideband amplifier. However the WM8501 does contain an internal low pass filter which should be adequate in most applications.

PCB LAYOUT RECOMMENDATIONS

Care should be taken in the layout of the PCB that the WM8501 is to be mounted to. The following notes will help in this respect:

1. **The VDD supply to the device should be as noise free as possible.** This can be accomplished to a large degree with a 10uF bulk capacitor placed locally to the device and a 0.1uF high frequency decoupling capacitor placed as close to the VDD pin as possible. It is best to place the 0.1uF capacitor directly between the VDD and GND pins of the device on the same layer to minimize track inductance and thus improve device decoupling effectiveness.
2. **The VMID pin should be as noise free as possible.** This pin provides the decoupling for the on chip reference circuits and thus any noise present on this pin will be directly coupled to the device outputs. In a similar manner to the VDD decoupling described above, this pin should be decoupled with a 10uF bulk capacitor local to the device and a 0.1uF capacitor as close to the VMID pin as possible.
3. **Separate analogue and digital track routing from each other.** The device is split into analogue (pins 5 – 9) and digital (pins 1 – 4 and pins 10 – 14) sections that allow the routing of these signals to be easily separated. By physically separating analogue and digital signals, crosstalk from the PCB can be minimized.
4. **Use an unbroken solid GND plane.** To achieve best performance from the device, it is advisable to have either a GND plane layer on a multilayer PCB or to dedicate one side of a 2 layer PCB to be a GND plane. For double sided implementations it is best to route as many signals as possible on the device mounted side of the board, with the opposite side acting as a GND plane. The use of a GND plane greatly reduces any electrical emissions from the PCB and minimizes crosstalk between signals.

Further advice on this subject is available in WAN0129, available from www.wolfsonmicro.com

PACKAGE DRAWING

D: 14 PIN SOIC 3.9mm Wide Body

DM001.C

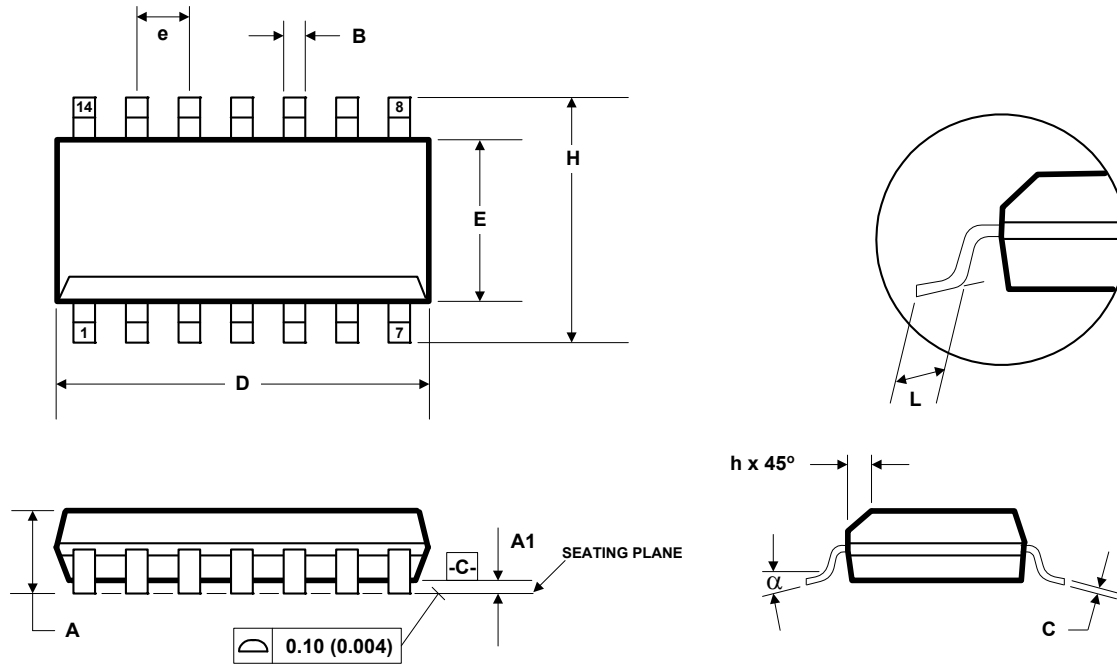

Symbols	Dimensions (MM)		Dimensions (Inches)	
	MIN	MAX	MIN	MAX
A	1.35	1.75	0.0532	0.0688
A1	0.10	0.25	0.0040	0.0098
B	0.33	0.51	0.0130	0.0200
C	0.19	0.25	0.0075	0.0098
D	8.55	8.75	0.3367	0.3444
E	3.80	4.00	0.1497	0.1574
e	1.27 BSC		0.05 BSC	
H	5.80	6.20	0.2284	0.2440
h	0.25	0.50	0.0099	0.0196
L	0.40	1.27	0.0160	0.0500
α	0°	8°	0°	8°
REF:	JEDEC.95, MS-012			

- NOTES:
 A. ALL LINEAR DIMENSIONS ARE IN MILLIMETERS (INCHES).
 B. THIS DRAWING IS SUBJECT TO CHANGE WITHOUT NOTICE.
 C. BODY DIMENSIONS DO NOT INCLUDE MOLD FLASH OR PROTRUSION, NOT TO EXCEED 0.25MM (0.010IN).
 D. MEETS JEDEC.95 MS-012, VARIATION = AB. REFER TO THIS SPECIFICATION FOR FURTHER DETAILS.

IMPORTANT NOTICE

Wolfson Microelectronics plc ("Wolfson") products and services are sold subject to Wolfson's terms and conditions of sale, delivery and payment supplied at the time of order acknowledgement.

Wolfson warrants performance of its products to the specifications in effect at the date of shipment. Wolfson reserves the right to make changes to its products and specifications or to discontinue any product or service without notice. Customers should therefore obtain the latest version of relevant information from Wolfson to verify that the information is current.

Testing and other quality control techniques are utilised to the extent Wolfson deems necessary to support its warranty. Specific testing of all parameters of each device is not necessarily performed unless required by law or regulation.

In order to minimise risks associated with customer applications, the customer must use adequate design and operating safeguards to minimise inherent or procedural hazards. Wolfson is not liable for applications assistance or customer product design. The customer is solely responsible for its selection and use of Wolfson products. Wolfson is not liable for such selection or use nor for use of any circuitry other than circuitry entirely embodied in a Wolfson product.

Wolfson's products are not intended for use in life support systems, appliances, nuclear systems or systems where malfunction can reasonably be expected to result in personal injury, death or severe property or environmental damage. Any use of products by the customer for such purposes is at the customer's own risk.

Wolfson does not grant any licence (express or implied) under any patent right, copyright, mask work right or other intellectual property right of Wolfson covering or relating to any combination, machine, or process in which its products or services might be or are used. Any provision or publication of any third party's products or services does not constitute Wolfson's approval, licence, warranty or endorsement thereof. Any third party trade marks contained in this document belong to the respective third party owner.

Reproduction of information from Wolfson datasheets is permissible only if reproduction is without alteration and is accompanied by all associated copyright, proprietary and other notices (including this notice) and conditions. Wolfson is not liable for any unauthorised alteration of such information or for any reliance placed thereon.

Any representations made, warranties given, and/or liabilities accepted by any person which differ from those contained in this datasheet or in Wolfson's standard terms and conditions of sale, delivery and payment are made, given and/or accepted at that person's own risk. Wolfson is not liable for any such representations, warranties or liabilities or for any reliance placed thereon by any person.

ADDRESS:

Wolfson Microelectronics plc
Westfield House
26 Westfield Road
Edinburgh
EH11 2QB
United Kingdom

Tel :: +44 (0)131 272 7000

Fax :: +44 (0)131 272 7001

Email :: sales@wolfsonmicro.com

REVISION HISTORY

DATE	REV	DESCRIPTION OF CHANGES	CHANGED BY
31/01/13	4.3	Order codes changed from WM8501GED/V and WM8501GED/RV to WM8501CGED and WM8501CGED/R to reflect copper wire bonding and MSL change.	
31/01/13	4.3	MSL changed from MSL3 to MSL1.	

Mouser Electronics

Authorized Distributor

Click to View Pricing, Inventory, Delivery & Lifecycle Information:

[Cirrus Logic:](#)

[WM8501CGED](#) [WM8501CGED/R](#)

Данный компонент на территории Российской Федерации

Вы можете приобрести в компании MosChip.

Для оперативного оформления запроса Вам необходимо перейти по данной ссылке:

<http://moschip.ru/get-element>

Вы можете разместить у нас заказ для любого Вашего проекта, будь то серийное производство или разработка единичного прибора.

В нашем ассортименте представлены ведущие мировые производители активных и пассивных электронных компонентов.

Нашей специализацией является поставка электронной компонентной базы двойного назначения, продукции таких производителей как XILINX, Intel (ex.ALTERA), Vicor, Microchip, Texas Instruments, Analog Devices, Mini-Circuits, Amphenol, Glenair.

Сотрудничество с глобальными дистрибьюторами электронных компонентов, предоставляет возможность заказывать и получать с международных складов практически любой перечень компонентов в оптимальные для Вас сроки.

На всех этапах разработки и производства наши партнеры могут получить квалифицированную поддержку опытных инженеров.

Система менеджмента качества компании отвечает требованиям в соответствии с ГОСТ Р ИСО 9001, ГОСТ РВ 0015-002 и ЭС РД 009

Офис по работе с юридическими лицами:

105318, г.Москва, ул.Щербаковская д.3, офис 1107, 1118, ДЦ «Щербаковский»

Телефон: +7 495 668-12-70 (многоканальный)

Факс: +7 495 668-12-70 (доб.304)

E-mail: info@moschip.ru

Skype отдела продаж:

moschip.ru

moschip.ru_4

moschip.ru_6

moschip.ru_9