

7Seg-DB (#28312 & #28313): 4-Digit, 7-Segment LED Display Module Hardware Manual

General Description

The 7Seg-DB modules each provide 4 digits of LED display, with some alphabetic and punctuation capability. The master module, 7Seg-DB(M) (#28312), plugs directly into a Parallax motherboard. With the master module installed, up to seven additional slave modules, 7Seg-DB(S) can be added, daisy-chain-style, for a total of 32 contiguously-displayed digits.

Features

- Plug-compatible with Parallax motherboards.
- Displays four digits (alphanumeric characters) apiece.
- Includes shift registers for refresh with 25% duty cycle.
- Includes a dimming input for PWM control of overall intensity.
- Compatible with future daisy-chainable I/O devices.
- Downloadable AVR firmware handles refresh, character display, and special effects automatically.
- Compatible with both 3.3V and 5V Vdd installations.

Application Ideas

- Annunciators.
- Visual Sensor Feedback.
- Desktop weather stations.
- Scrolling marquees.
- Debugging output.

What's Included

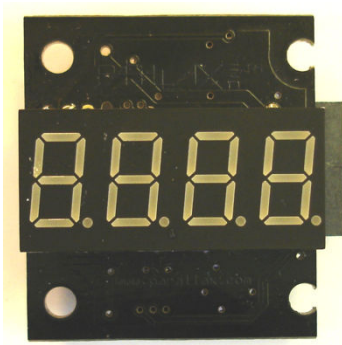

7Seg-DB module,
with amber LED

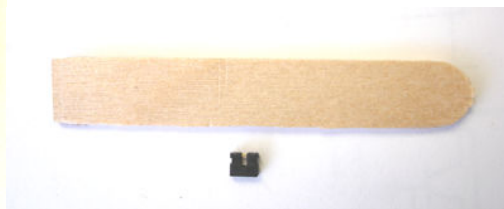

LED extractor and jumper (supplied with
master module only).

What You Need to Provide

- Parallax motherboard.

Available Accessories

- Red, green, and blue replacement displays.

Master Module Installation

One master module is required for every installation. The master module can be plugged into any daughterboard socket on a Parallax motherboard. Most of the time, you'll want to use the "B" socket, and the examples in this document use the "B" socket exclusively. Below is a photo of a master module plugged into the MoBoStamp-pe's "B" socket:

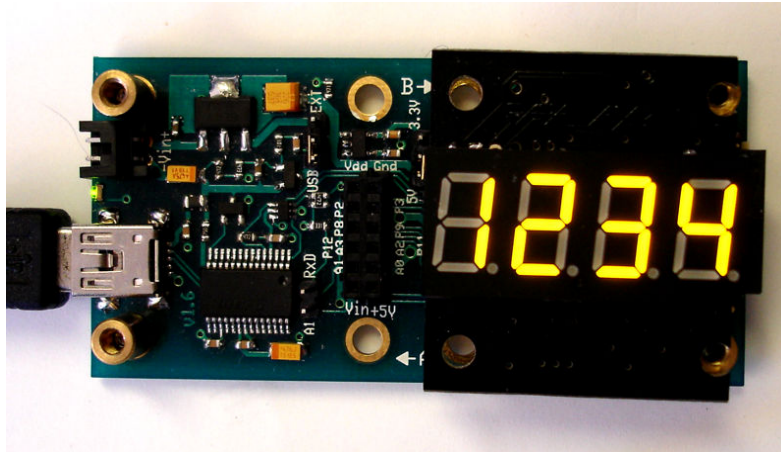

Theoretically, you could plug master modules into *both* sockets. However, even though they will line up with one another, one will be inverted with respect to the other. At some point, if there's sufficient demand, there will be a firmware driver available for use with an upside-down module. But using one master with a daisy-chained slave is preferred over the two-master approach.

MoBoStamp-pe

Before plugging the 7Seg-DB into your MoBoStamp-pe, load the AVR firmware for this device (available for download on the 7Seg-DB product page, http://www.parallax.com/detail.asp?product_id=28312. This firmware can be installed for either the "A" or "B" daughterboard sockets, socket "B" being the usual destination. The firmware is uploaded with the program, LoadAVR.exe, available on the MoBoStamp-pe product page: http://www.parallax.com/detail.asp?product_id=28300. Before uploading, however, you may wish to redesign the default character set to your own specs. This can be done with the PC program, 7Seg_Font.exe, available from the 7Seg-DB product page.

After successfully installing the AVR firmware, the 7Seg-DB functions can be programmed in PBASIC, as outlined in the 7Seg-DB AVR firmware manual, which is also available on the 7Seg-DB product page.

MoBoProp

To use the 7Seg-DB with your MoBoProp motherboard, just plug it into either daughterboard socket, socket "B" being its usual home. To use the 7Seg-DB as an output device for the Propeller, you will need to specify the 7Seg object (available from the Propeller Object Exchange) with your programs under the "OBJ" header and call the public routines contained therein.

Slave Module Installation

Once the master module has been installed, up to seven additional slave modules can be plugged into it, one after the other, in a daisy chain. On the back of every purchased master module, there is a jumper installed on the two-pin, right-angle header. (See photo below.)

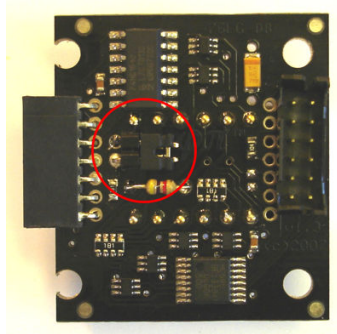

Before plugging in the master module, remove this jumper from the master device. Then, after daisy chaining all the slave devices, install the jumper on the last device in the chain, as shown below:

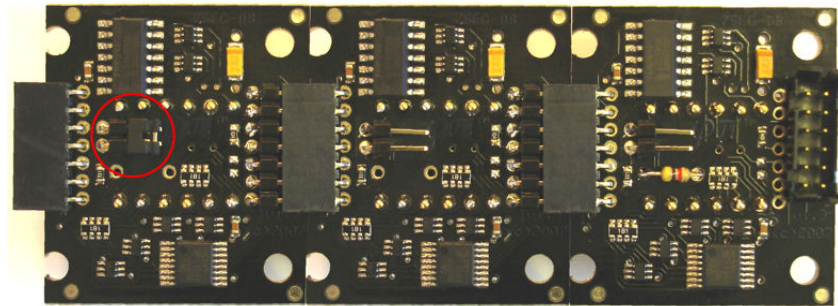

Once this is done, the master module with its daisy-chained slaves can be plugged into the motherboard. To support the slave units physically, Parallax will soon be offering extrusions designed for that purpose. You can also employ the screw holes (#4 or 3mm), along with standoffs for mounting behind a panel.

IMPORTANT NOTE: When powering your system from the USB port, eight 7Seg-DBs running at maximum intensity will draw more current than the USB port can provide. This will cause the motherboard to reset when the USB supply voltage is drawn down too far. To avoid this, use a lower intensity setting to keep current draw to a minimum. See the AVR firmware docs for how to adjust the LED intensity.

Changing LED Displays

The four-digit LEDs are socketed, so they can be exchanged with similar units of a different color. The sockets hold the LEDs very tightly, and they can be difficult to remove. For this reason, an extraction tool is provided for safe LED removal.

IMPORTANT NOTE: Do *not* use any metallic implements (e.g. screwdrivers, knife blades, etc.) to extract the LED. Doing so will mar the plastic LED housing and could damage the LED and/or the 7Seg-DB printed circuit board.

Using the removal tool provided, slip the thin end under the top or bottom of the LED and pry gently until it lifts slightly from the socket. Repeat on the other side. Keep switching sides and prying by little bits at a time until the LED is free.

To install the replacement LED, make sure that it's oriented correctly. Use the image printed (very faintly) on the circuit board as a guide. The decimal points indicate the correct orientation. (See photo below.)

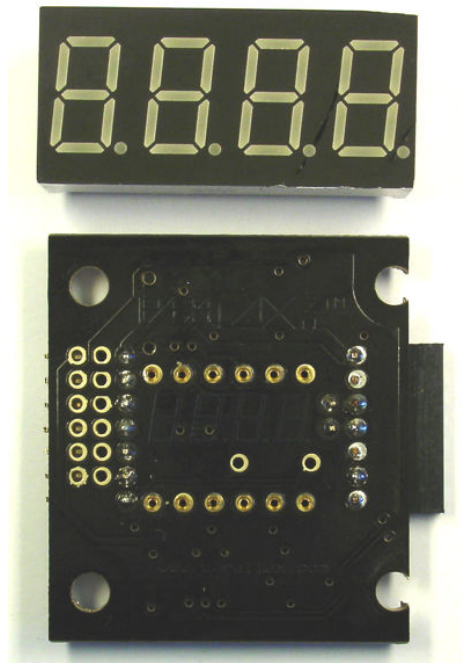

Schematic

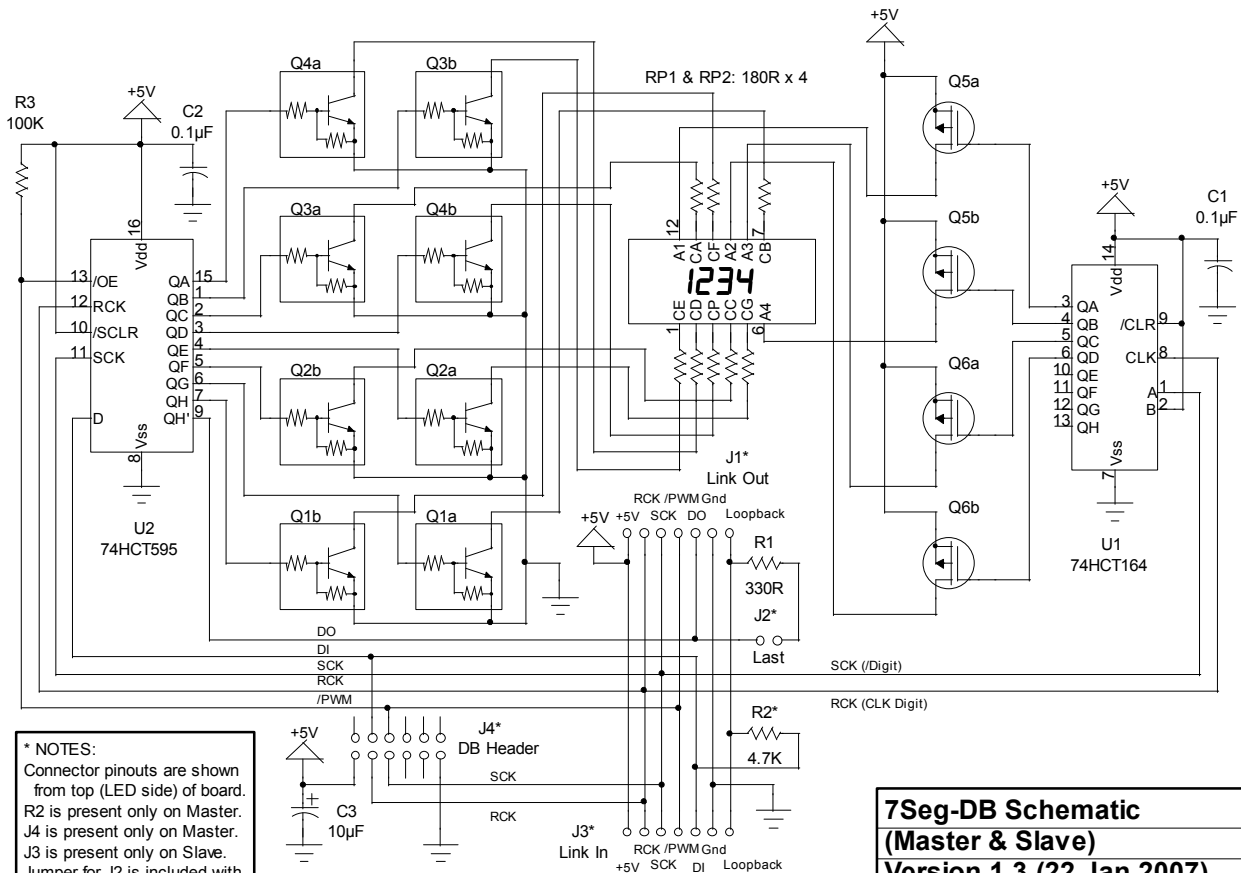

*** NOTES:**
 Connector pinouts are shown from top (LED side) of board.
 R2 is present only on Master.
 J4 is present only on Master.
 J3 is present only on Slave.
 Jumper for J2 is included with Master, but not Slaves.

7Seg-DB Schematic
(Master & Slave)
Version 1.3 (22 Jan 2007)
© 2007 Bueno systems, Inc.

Данный компонент на территории Российской Федерации

Вы можете приобрести в компании MosChip.

Для оперативного оформления запроса Вам необходимо перейти по данной ссылке:

<http://moschip.ru/get-element>

Вы можете разместить у нас заказ для любого Вашего проекта, будь то серийное производство или разработка единичного прибора.

В нашем ассортименте представлены ведущие мировые производители активных и пассивных электронных компонентов.

Нашей специализацией является поставка электронной компонентной базы двойного назначения, продукции таких производителей как XILINX, Intel (ex.ALTERA), Vicor, Microchip, Texas Instruments, Analog Devices, Mini-Circuits, Amphenol, Glenair.

Сотрудничество с глобальными дистрибьюторами электронных компонентов, предоставляет возможность заказывать и получать с международных складов практически любой перечень компонентов в оптимальные для Вас сроки.

На всех этапах разработки и производства наши партнеры могут получить квалифицированную поддержку опытных инженеров.

Система менеджмента качества компании отвечает требованиям в соответствии с ГОСТ Р ИСО 9001, ГОСТ РВ 0015-002 и ЭС РД 009

Офис по работе с юридическими лицами:

105318, г.Москва, ул.Щербаковская д.3, офис 1107, 1118, ДЦ «Щербаковский»

Телефон: +7 495 668-12-70 (многоканальный)

Факс: +7 495 668-12-70 (доб.304)

E-mail: info@moschip.ru

Skype отдела продаж:

moschip.ru

moschip.ru_4

moschip.ru_6

moschip.ru_9