

Low-frequency, high EMI resistance accelerometers

HV100LF and HV200LF series

Wilcoxon’s HV series are designed for low-frequency applications where high electrical isolation between the sensor and machine is required. HV sensors can withstand arcing between the sensor base and its internal electronics to levels as high as 6,000 volts. The sensors offer improved EMI resistance in areas where high electromagnetic interference occurs, such as wind turbines, railway systems and other high-voltage generators. Improvements in EFT and ESD resistance improve survivability during extreme transient events. The HV100LF/200LF series has superior performance down to 0.1 Hz.



Models available

HV models	Output connector	Integral mounting	Sensitivity
HV100LF	4 pin, M12	M8 x 1.25	100 mV/g
HV100LF-500			500 mV/g
HV101LF		1/4-28 UNF	100 mV/g
HV101LF-500			500 mV/g
HV102LF		M6	100 mV/g
HV102LF-500			500 mV/g
HV200LF	2 pin, MIL-5015	1/4-28 UNF	100 mV/g
HV200LF-500			500 mV/g
HV201LF		M8 x 1.25	100 mV/g
HV201LF-500			500 mV/g
HV202LF		M6	100 mV/g
HV202LF-500			500 mV/g

Key features

- Ultra low-frequency measurements
- Case-base isolated up to 6 kV
- Ideal for power generation applications
- Rapid shock recovery
- Improved EMI resistance
- Manufactured in an approved ISO 9001 facility

Certifications



Note: Due to continuous process improvement, specifications are subject to change without notice. This document is cleared for public release.

Low-frequency, high EMI resistance accelerometers



HV100LF and HV200LF series

SPECIFICATIONS

	LF series	LF-500 series
Sensitivity, $\pm 5\%$, 25°C	100 mV/g	500 mV/g
Acceleration range, VDC > 22 V	80 g peak	10 g peak
Amplitude nonlinearity	1%	
Frequency response:		
$\pm 5\%$	0.35 - 5,000 Hz	
$\pm 10\%$	0.25 - 7,000 Hz	
± 3 dB	0.1 - 11,000 Hz	
Resonance frequency, nominal	28 kHz	
Transverse sensitivity, max	5% of axial	
Temperature response:		
-25°C	-10%	
+120°C	+15%	
Temperature range	-50° to +120° C	
Power requirement:		
Voltage source	18 - 30 VDC	
Current regulating diode	2 - 10 mA	
Dielectric withstand voltage between connector and surface:		
6,000 VDC	1 min.	
5,000 VAC	1 min.	
Electrical noise, equiv. g:		
Broadband 2.5 Hz to 25 kHz	400 μ g rms	250 μ g rms
Spectral 10 Hz	10 μ g/ $\sqrt{\text{Hz}}$	3 μ g/ $\sqrt{\text{Hz}}$
100 Hz	5 μ g/ $\sqrt{\text{Hz}}$	2 μ g/ $\sqrt{\text{Hz}}$
1,000 Hz	5 μ g/ $\sqrt{\text{Hz}}$	2 μ g/ $\sqrt{\text{Hz}}$
Output impedance, max	100 Ω	300 Ω
Impedance, between connector and base:		
DC	>100 G Ω	
100 Hz	>100 M Ω	
1.0 kHz	>10 M Ω	
10 kHz	>1 M Ω	
Bias output voltage	13 VDC	
Grounding	case isolated, internally shielded	
Vibration limit	500 g peak	
Shock limit	5,000 g peak	
Electromagnetic sensitivity, equiv. g, max	70 μ g/gauss	
Sealing	hermetic	
Base strain sensitivity, max	0.0002 g/ μ strain	
Sensing element design	PZT, shear	
Sensor case material	stainless steel	
Isolation material	ceramic	
Recommended cabling	J10 / J9T2A	

Function	Connector pin
signal	P1
to pin 3 inner shield	P2
common	P3
case	P4
connector shell	case

Function	Connector pin
signal	A
common	B
connector shell	case

See page 3 for further specifications, dimensions and drawings.

Note: Due to continuous process improvement, specifications are subject to change without notice. This document is cleared for public release.

HV100LF series

SPECIFICATIONS		HV100LF/HV100LF-500	HV101LF/HV101LF-500	HV102LF/HV102LF-500
Output connector¹		4 pin M12	4 pin M12	4 pin M12
Integral mounting		M8 x 1.25	1/4-28 UNF	M6 x 1.00
Dimensions:	A	1.98 in. (50.3 mm)	1.98 in. (50.3 mm)	1.98 in. (50.3 mm)
	B	0.33 in. (8.4 mm)	0.33 in. (8.4 mm)	0.33 in. (8.4 mm)
	C	1.21 in. (30.8 mm)	1.21 in. (30.8 mm)	1.21 in. (30.8 mm)
Weight		126 grams (4.44 oz)	126 grams (4.44 oz)	126 grams (4.44 oz)

Notes: ¹ For best performance, it is recommended that the connector shell be tied to the cable shield.

Recommended connector: R75S

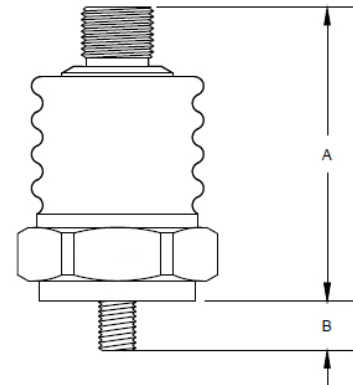
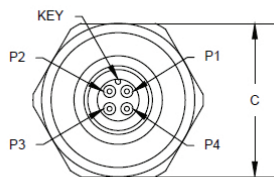

HV200LF series

SPECIFICATIONS		HV200LF/HV200LF-500	HV201LF/HV201LF-500	HV202LF/HV202LF-500
Output connector¹		2 pin MIL-5015	2 pin MIL-5015	2 pin MIL-5015
Integral mounting		1/4-28 UNF	M8 x 1.25	M6 x 1.00
Dimensions:	A	2.21 in. (56.0 mm)	2.21 in. (56.0 mm)	2.21 in. (56.0 mm)
	B	0.33 in. (8.4 mm)	0.33 in. (8.4 mm)	0.33 in. (8.4 mm)
	C	1.21 in. (30.8 mm)	1.21 in. (30.8 mm)	1.21 in. (30.8 mm)
Weight		122 grams (4.35 oz)	122 grams (4.35 oz)	122 grams (4.35 oz)

Notes: ¹ For best performance, it is recommended that the connector shell be tied to the cable shield.

Recommended connector: R6Q

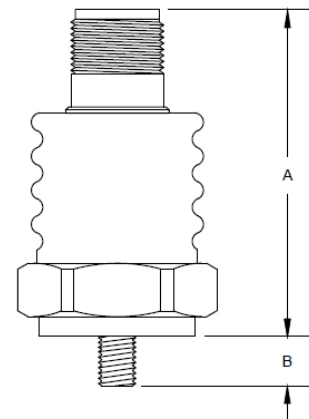
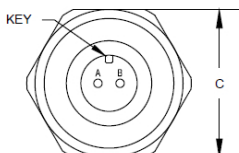

Note: Due to continuous process improvement, specifications are subject to change without notice.
This document is cleared for public release.

Данный компонент на территории Российской Федерации

Вы можете приобрести в компании MosChip.

Для оперативного оформления запроса Вам необходимо перейти по данной ссылке:

<http://moschip.ru/get-element>

Вы можете разместить у нас заказ для любого Вашего проекта, будь то серийное производство или разработка единичного прибора.

В нашем ассортименте представлены ведущие мировые производители активных и пассивных электронных компонентов.

Нашей специализацией является поставка электронной компонентной базы двойного назначения, продукции таких производителей как XILINX, Intel (ex.ALTERA), Vicor, Microchip, Texas Instruments, Analog Devices, Mini-Circuits, Amphenol, Glenair.

Сотрудничество с глобальными дистрибьюторами электронных компонентов, предоставляет возможность заказывать и получать с международных складов практически любой перечень компонентов в оптимальные для Вас сроки.

На всех этапах разработки и производства наши партнеры могут получить квалифицированную поддержку опытных инженеров.

Система менеджмента качества компании отвечает требованиям в соответствии с ГОСТ Р ИСО 9001, ГОСТ РВ 0015-002 и ЭС РД 009

Офис по работе с юридическими лицами:

105318, г.Москва, ул.Щербаковская д.3, офис 1107, 1118, ДЦ «Щербаковский»

Телефон: +7 495 668-12-70 (многоканальный)

Факс: +7 495 668-12-70 (доб.304)

E-mail: info@moschip.ru

Skype отдела продаж:

moschip.ru

moschip.ru_4

moschip.ru_6

moschip.ru_9