

Industrial PCs applied in

- / Logistics and Warehouse
- / Heavy Duty
- / Fleet Management
- / Stationary and Automation



Catalog V5.20
Mounting
XMT 5 Family

The software and hardware designations as well as the brand names used in this catalog are in most cases also registered trademarks and are subject to the international law (trademark, brand and protection laws).

We recognize all national and international trademarks and product names.

We reserve the right to modify the contents of this catalog at any time and without prior notice.

DLoG GmbH assumes no liability for technical inaccuracies, typographic errors or faults in this catalog.

DLoG GmbH also assumes no liability for damages caused directly or indirectly by the delivery, performance or usage of this material.

This catalog is protected by copyright. Duplication, in whole or in part, is not permitted without prior written approval of DLoG GmbH.

Title:	Mounting Solutions for XMT 5 Industrial PCs
Completed on:	06/26/2015
Version:	V5.20

© Copyright 2007-2015

By DLoG GmbH

Industriestraße 15

D-82110 Germering

All rights reserved

Phone: (+49) 89 / 41 11 91 0

Mail: info@advantech-dlog.com

Internet: www.advantech-dlog.com

1.	Operation Classes 5M3, 5M2 and 5M1	4
2.	XMT 5/7	5
2.1.	XMT 5/7 Mounting brackets / Devices.....	5
2.1.1.	XMT 5/7 Mounting bracket, 15° adjustable.....	5
2.1.2.	XMT 5/7 Mounting device wall, rear side	6
2.1.3.	XMT 5/7 Clamp mount high	6
2.1.4.	XMT 5/7 Mounting bracket 180° adjustable.....	7
2.2.	XMT 5/7 RAM Mount	8
2.2.1.	XMT 5/7 RAM Mount Set short 1.5".....	8
2.2.2.	XMT 5/7 RAM Mount Set long 1.5"	9
2.2.3.	XMT 5/7 RAM Mount Set Pipe 1.25", 90 mm.....	10
2.2.4.	XMT 5/7 RAM Mount Set Pipe diameter 1.25", 150 mm	11
2.2.5.	XMT 5/7 RAM Mount Set long 2.25", 215 mm	12
2.2.6.	XMT 5/7 RAM Mount Set (Plate/Arm 130 mm/Plate).....	13
2.2.7.	XMT 5/7 RAM Mount Pipe	13
2.2.8.	XMT 5/7 RAM Mount Set double, Arm 150 mm.....	14
2.2.9.	XMT 5/7 RAM Mount Set double, Arm 150 mm, complete	14
2.2.10.	XMT 5/7 Adapter plate with RAM-VESA-Plate 1.5" or 2.25".....	15
2.3.	XMT 5/7 Wall adapter	16
2.3.1.	XMT 5/7 Wall adapter I-30".....	16
2.3.2.	XMT 5/7 Wall adapter I-50".....	16
2.4.	XMT 5/7 Clamp mount small	17
3.	XMT 5/10	18
3.1.	XMT 5/10 Mounting brackets / Devices.....	18
3.1.1.	XMT 5/10 Mounting bracket, 15° gradient	18
3.1.2.	XMT 5/10 Mounting device wall, rear side	19
3.1.3.	XMT 5/10 Wall adapter I-30	19
3.1.4.	XMT 5/10 Wall adapter I-50	20
3.1.5.	XMT 5/10 Clamp mount high	20
3.2.	XMT 5/10 RAM Mount	21
3.2.1.	XMT 5/10 RAM Mount Set short 2.25" (1 Arm, 130 mm).....	21
3.2.2.	XMT 5/10 RAM Mount Set long 2.25" (1 Arm, 215 mm)	21
3.2.3.	XMT 5/10 RAM Mount Set double arm 1.5" (2 Arms, 150 mm)	22
3.3.	XMT 5/10 Clamp mount small	22

1. Operation Classes 5M3, 5M2 and 5M1

This catalog shows the mounting solutions for the Advantech-DLoG XMT 5 Industrial PCs.

It specifies whether the listed mounting brackets are suitable for mobile use, restricted mobile application or stationary use.

These uses correspond to the operation classes 5M3, 5M2 and 5M1 for mechanical environmental conditions.

The following standards offer a practical means of reference:

- DIN EN 60721-3-5: 1998 classification of environmental conditions, part 3, section 5: Use on and in ground vehicles.
- Military standard MIL-STD 810F: 2000.

5M3 Mobile use

Operational environments with **high** energy vibrations and **high** energy shocks as well as **rough** handling/transport compliant with:

- Operation class **5M3** according to DIN EN 60721-3-5 or equivalent.
- Category **US Highway Truck** according to MIL-STD 810F.
- Examples: Vehicles without shock absorption: Fork lifts, unbalanced machines: Combustion engine of a construction machine.

5M2 Restricted mobile application

Operational environments with **low** energy vibrations and **high** energy shocks as well as **careful** handling/transport compliant with:

- Operation class **5M2** according to DIN EN 60721-3-5 or equivalent.
- Category **US Highway Truck** according to MIL-STD 810F.
- Examples: Vehicles with shock absorption: Driver's cab in a tractor, standing machines: Machine tools.

5M1 Stationary use

Operational environments with **low** energy vibrations and **medium** energy shocks as well as **very careful** handling/transport compliant with:

- Operation class **5M1** according to DIN EN 60721-3-5.
- Examples: Vehicles with very good shock absorption: Car dashboard, immobile mounting surfaces: Desk or wall.

2. XMT 5/7

2.1. XMT 5/7 Mounting brackets / Devices

2.1.1. XMT 5/7 Mounting bracket, 15° adjustable



Order number: DL-CMENT70279900

Technical data:

- 15° adjustable
- Includes screw set (Terminal-side)
- Suitable for mobile use according to class 5M3

2.1.2. XMT 5/7 Mounting device wall, rear side



Order number: DL-CMEMENT70129900

Technical data:

- Includes screw set (Terminal-side)
- Suitable for mobile use according to class 5M3

2.1.3. XMT 5/7 Clamp mount high

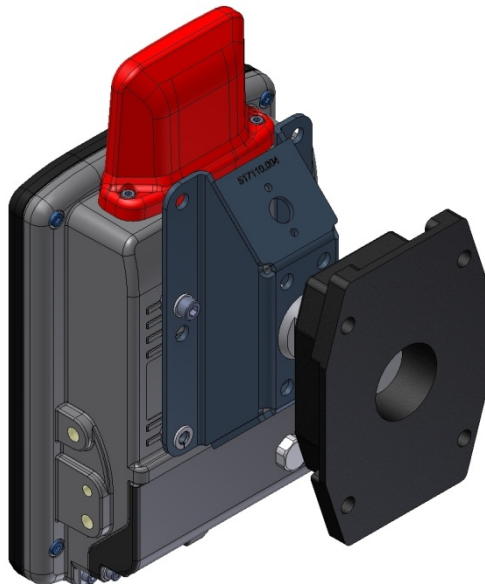

Order number: DL-CMEMENT70123400

Technical data:

- Includes screw set (Terminal-side)
- Suitable for mobile use according to class 5M3

Requires:

- Clamp mount high/low for mounting

2.1.4. XMT 5/7 Mounting bracket 180° adjustable

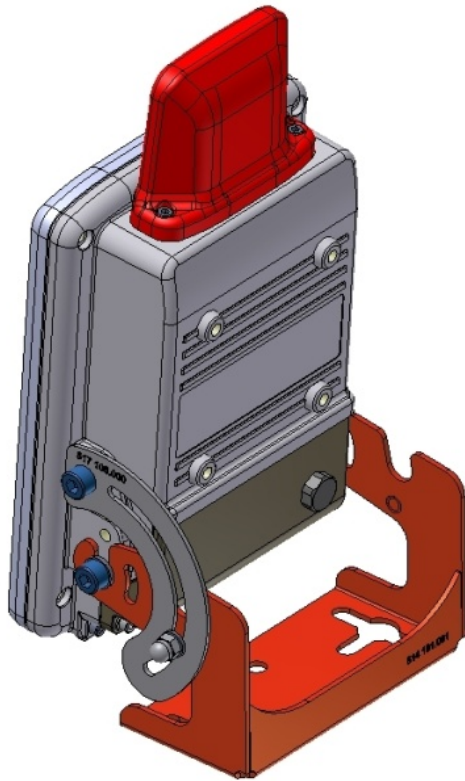

Order number: DL-CMEMT70129000

Technical data:

- 180° adjustable
- Suitable for stationary use according to class 5M1

2.2. XMT 5/7 RAM Mount

2.2.1. XMT 5/7 RAM Mount Set short 1.5"

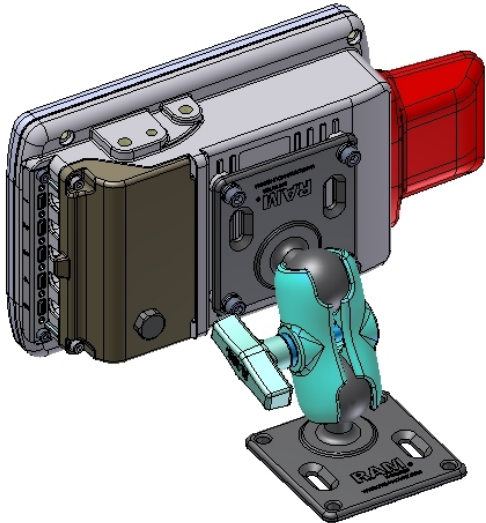

Order number: DL-CMEMT70128600

Technical data:

- Landscape and portrait use
- Build-up: Plate/Arm 90 mm/Plate
- Includes screw set (Terminal-side)
- Suitable for stationary use according to class 5M1

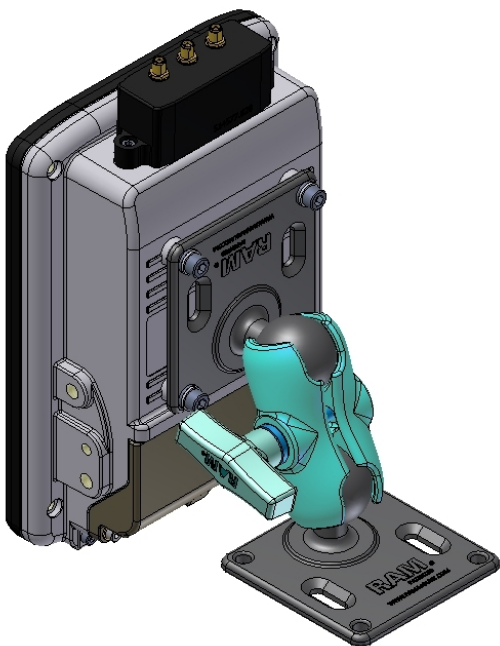

2.2.2. XMT 5/7 RAM Mount Set long 1.5"

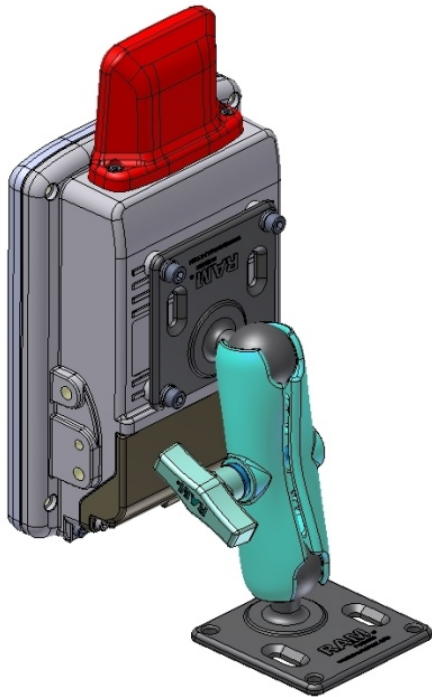

Order number: DL-CMEMENT70124000

Technical data:

- Landscape and portrait use
- Build-up: Plate/Arm 150 mm/Plate
- Includes screw set (Terminal-side)
- Suitable for stationary use according to class 5M1

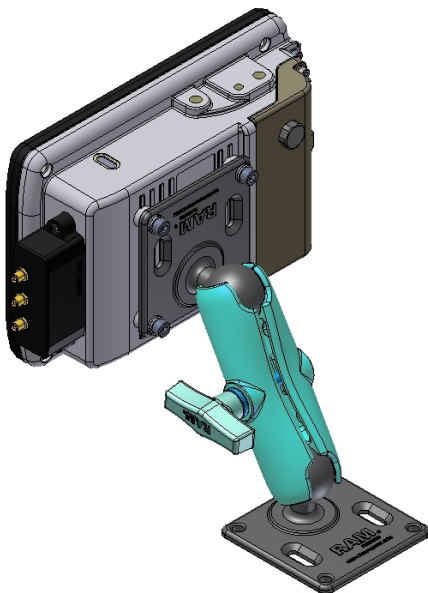

2.2.3. XMT 5/7 RAM Mount Set Pipe 1.25", 90 mm

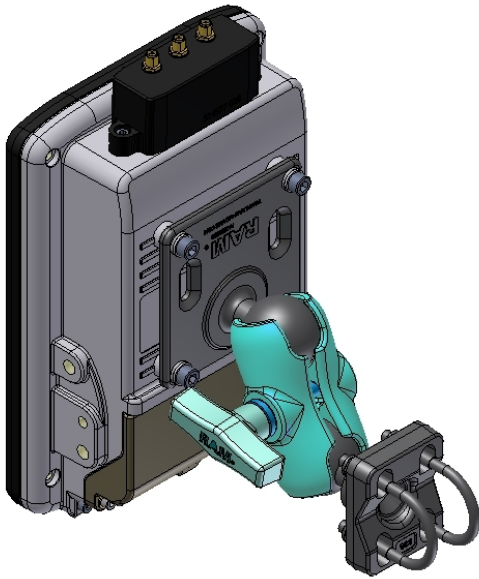

Order number: DL-CMEMT70124800

Technical data:

- Includes screw set (Terminal-side)
- Arm length 90 mm
- Pipe diameter max. 1.25" (3.18 cm)
- Suitable for stationary use according to class 5M1

2.2.4. XMT 5/7 RAM Mount Set Pipe diameter 1.25", 150 mm

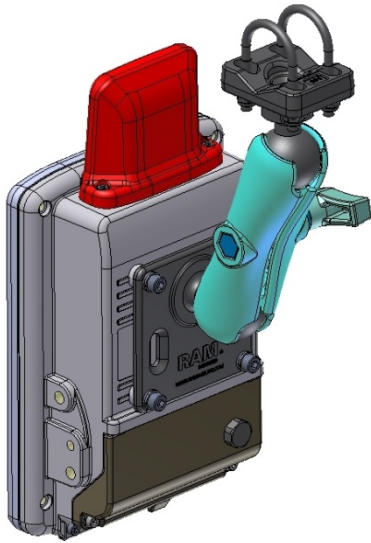

Order number: DL-CMEMT70128200

Technical data:

- Build-up: Plate/Arm 150 mm/U-Bolt-Plate
- Includes screw set (Terminal-side)
- Pipe diameter max. 1.25" (3,18 cm)
- Suitable for stationary use according to class 5M1

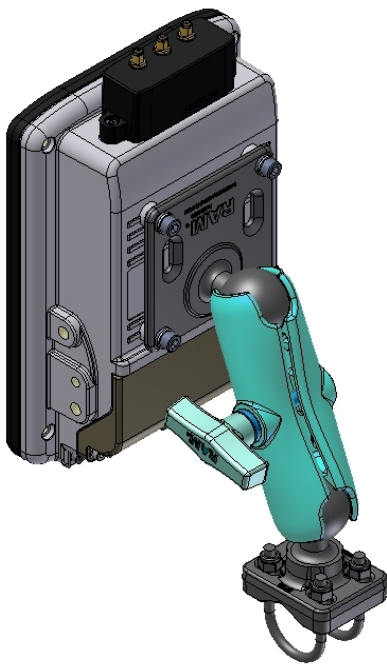

2.2.5. XMT 5/7 RAM Mount Set long 2.25", 215 mm

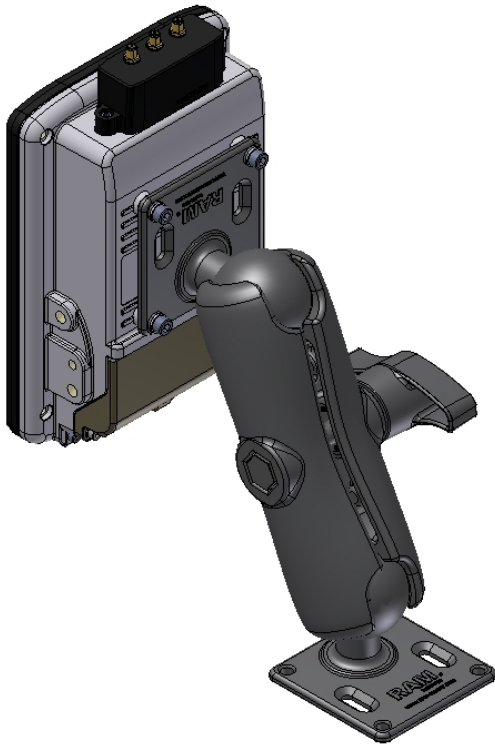

Order number: DL-CMEMT70129700

Technical data:

- Build-up: Plate/Arm 215 mm/Plate
- Includes screw set (Terminal-side)
- Suitable for mobile use according to class 5M3

2.2.6. XMT 5/7 RAM Mount Set (Plate/Arm 130 mm/Plate)

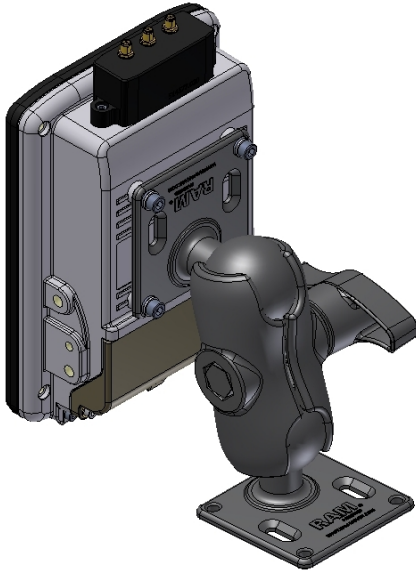

Order number: DL-CMENT70129800

Technical data:

- Build-up: Plate/Arm 130 mm/Plate
- Includes screw set (Terminal-side)
- Suitable for mobile use according to class 5M3

2.2.7. XMT 5/7 RAM Mount Pipe

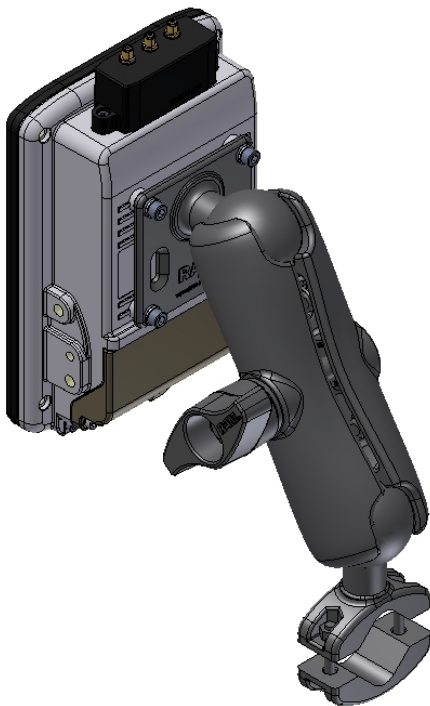

Order number: DL-CMENT70130800

Technical data:

- Includes screw set (Terminal-side)
- Suitable for mobile use according to class 5M3

2.2.8. XMT 5/7 RAM Mount Set double, Arm 150 mm

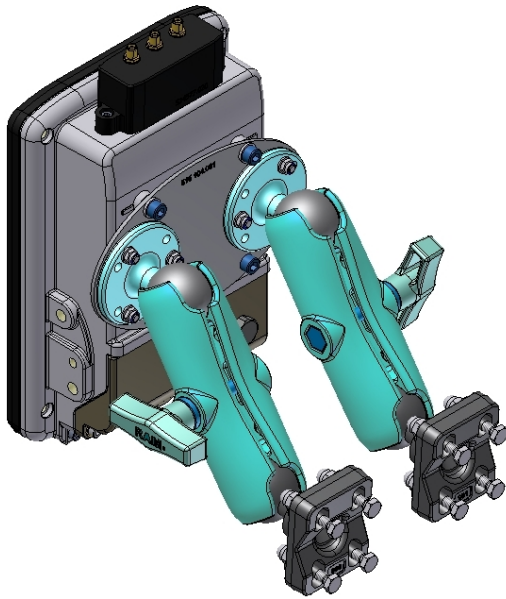

Order number: DL-CMEMT70119300

Technical data:

- Includes screw set (Terminal-side)
- Arm length 150 mm
- Suitable for mobile use according to class 5M3

2.2.9. XMT 5/7 RAM Mount Set double, Arm 150 mm, complete

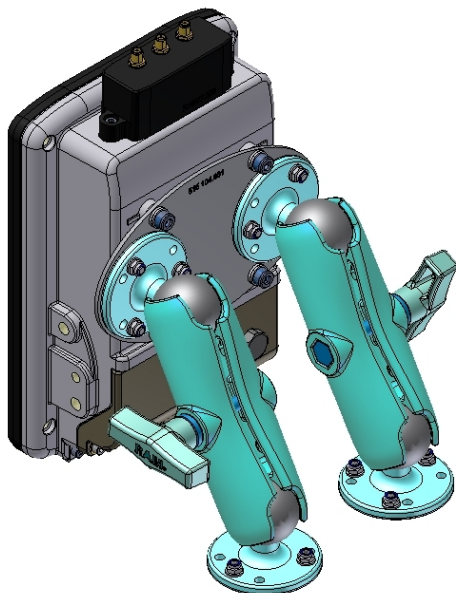

Order number: DL-BMEMT70146300

Technical data:

- Includes screw set (Terminal-side)
- Arm length 150 mm
- Suitable for mobile use according to class 5M3

2.2.10. XMT 5/7 Adapter plate with RAM-VESA-Plate 1.5" or 2.25"

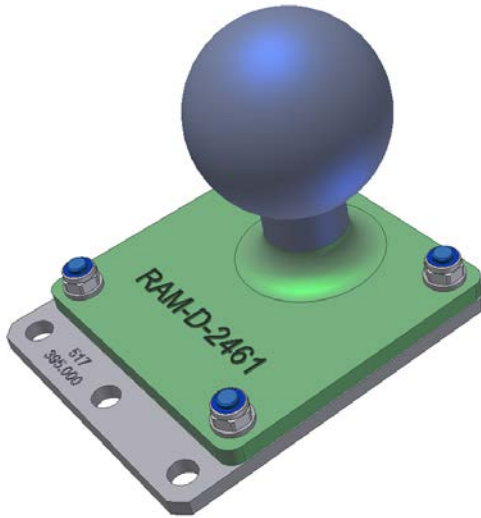

Order number: DL-MEMS70146200

Shown with RAM component

Technical data:

- Welded or screwed connection
- Depending on the configuration of the entire system, suitable for use class 5M1 through 5M3

2.3. XMT 5/7 Wall adapter

2.3.1. XMT 5/7 Wall adapter I-30"

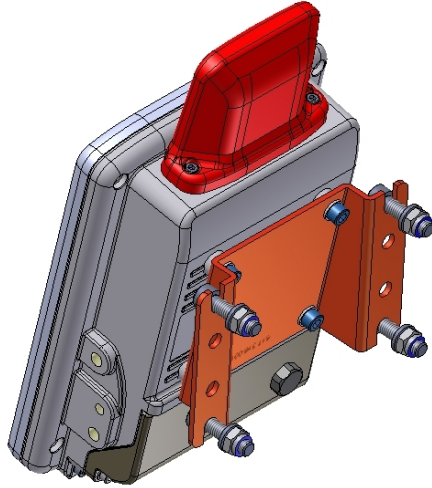

Order number: DL-CMENT70124400

Technical data:

- Incl. screw set for terminal and wall M6x10 and M8x30
- 10° inclination
- For walls of 12 mm to 17 mm thickness
- Suitable for mobile use according to class 5M3

2.3.2. XMT 5/7 Wall adapter I-50"

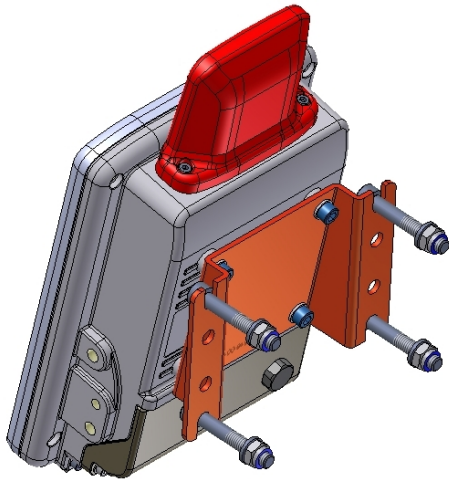

Order number: DL-CMENT70126000

Technical data:

- Incl. screw set for terminal and wall M6x10 and M8x50)
- 10° inclination
- For walls of 27 mm to 37 mm thickness
- Suitable for mobile use according to class 5M3

2.4. XMT 5/7 Clamp mount small

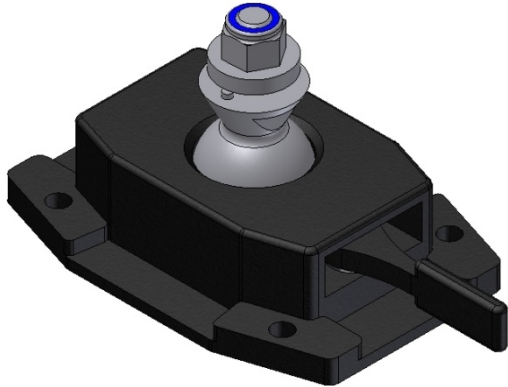

Order number: DL-ECF51029001

3. XMT 5/10

3.1. XMT 5/10 Mounting brackets / Devices

3.1.1. XMT 5/10 Mounting bracket, 15° gradient

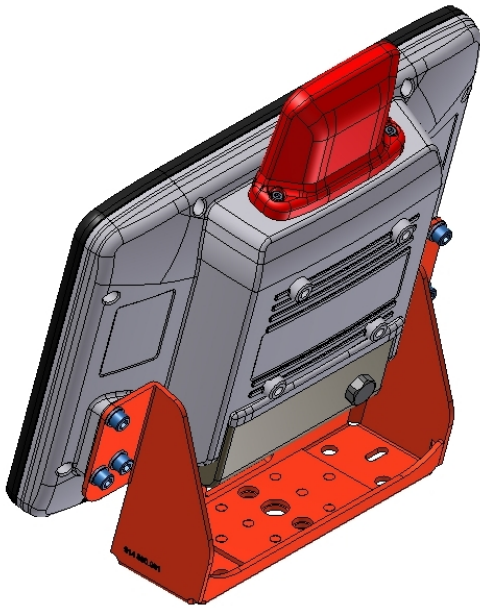

Order number: DL-CMENT70109500

Technical data:

- 15° gradient
- Includes screw set (Terminal-side)
- Suitable for mobile use according to class 5M3

3.1.2. XMT 5/10 Mounting device wall, rear side

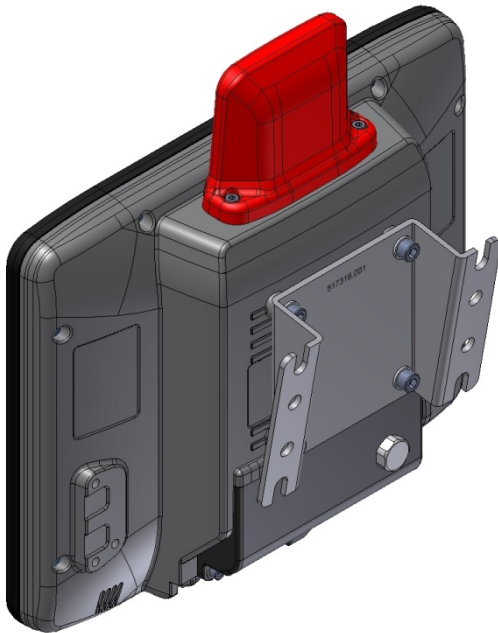

Order number: DL-CMENT70129900

Technical data:

- Includes screw set (Terminal-side)
- 10° inclination
- Suitable for mobile use according to class 5M3

3.1.3. XMT 5/10 Wall adapter I-30

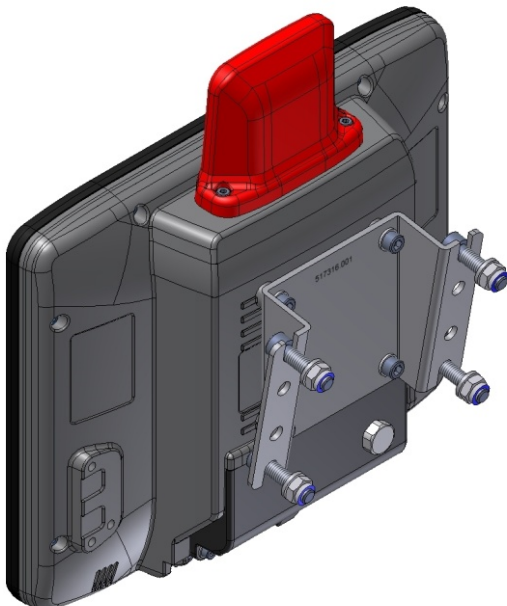

Order number: DL-CMENT70124400

Technical data:

- Incl. screw set for terminal and wall (M6x10 and M8x30)
- 10° inclination
- For walls of 12 mm to 17 mm thickness

3.1.4. XMT 5/10 Wall adapter I-50

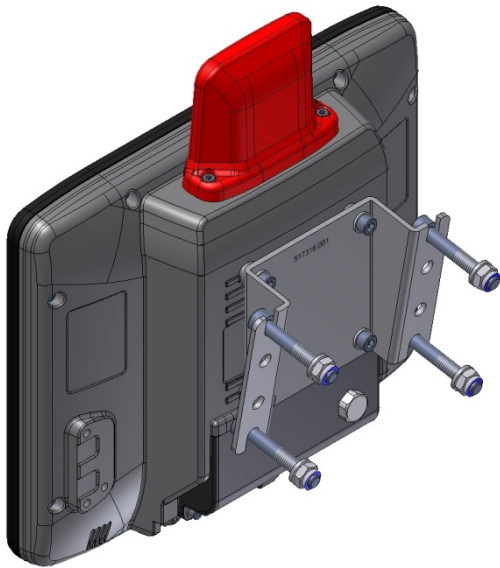

Order number: DL-CMEMT70126000

Technical data:

- Incl. screw set for terminal and wall M6x10 and M8x50
- 10° inclination
- For walls of 12 mm to 17 mm thickness

3.1.5. XMT 5/10 Clamp mount high

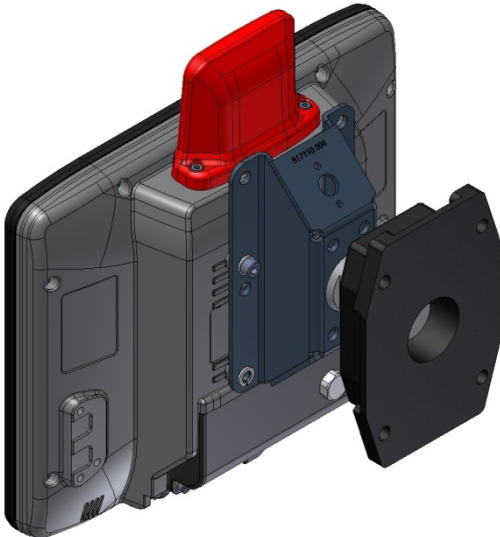

Order number: DL-CMEMT70123400

Technical data:

- Includes screw set (Terminal-side)
- Suitable for mobile use according to class 5M3

Requires:

- Clamp mount high/low for mounting

3.2. XMT 5/10 RAM Mount

3.2.1. XMT 5/10 RAM Mount Set short 2.25" (1 Arm, 130 mm)

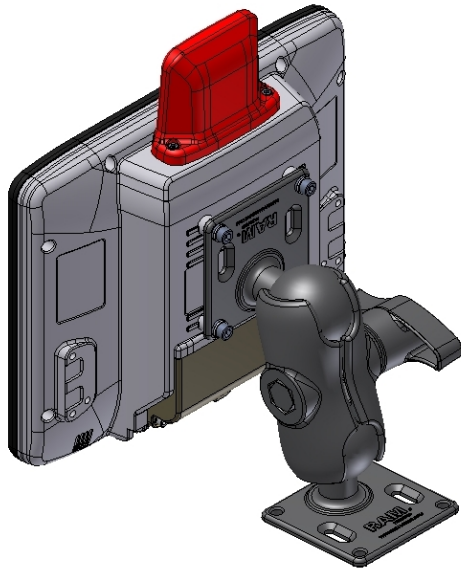

Order number: DL-CMENT70129800

Technical data:

- Build-up: Plate/Arm 130 mm/Plate
- Includes screw set (Terminal-side)
- Suitable for mobile use according to class 5M3

3.2.2. XMT 5/10 RAM Mount Set long 2.25" (1 Arm, 215 mm)

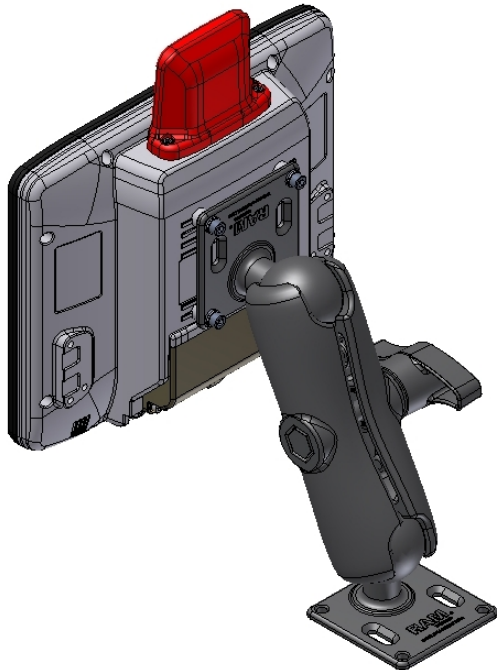

Order number: DL-CMENT70129700

Technical data:

- Build-up: Plate/Arm 215 mm/Plate
- Arm length 215 mm
- Includes screw set (Terminal-side)
- Suitable for mobile use according to class 5M3

3.2.3. XMT 5/10 RAM Mount Set double arm 1.5" (2 Arms, 150 mm)

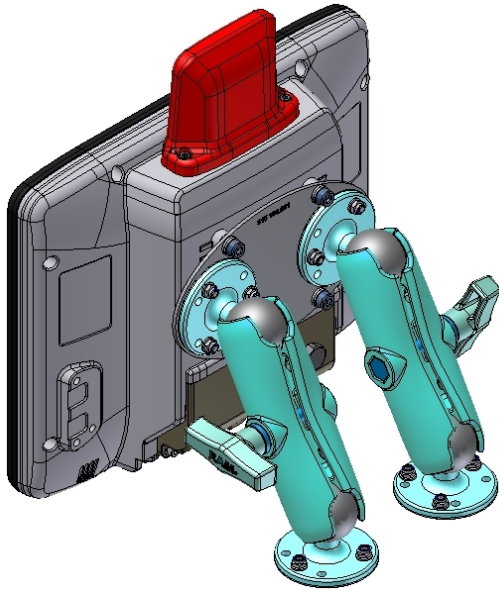

Order number: DL-BMEMT70146300

Technical data:

- Build-up: Plate/2 Arms 150 mm/Plate
- Arm length 150 mm
- Includes screw set (Terminal-side)
- Suitable for mobile use according to class 5M3

3.3. XMT 5/10 Clamp mount small

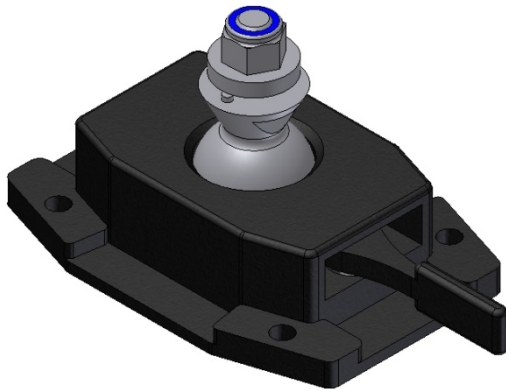

Order number: DL-CMECF51029001

Данный компонент на территории Российской Федерации

Вы можете приобрести в компании MosChip.

Для оперативного оформления запроса Вам необходимо перейти по данной ссылке:

<http://moschip.ru/get-element>

Вы можете разместить у нас заказ для любого Вашего проекта, будь то серийное производство или разработка единичного прибора.

В нашем ассортименте представлены ведущие мировые производители активных и пассивных электронных компонентов.

Нашей специализацией является поставка электронной компонентной базы двойного назначения, продукции таких производителей как XILINX, Intel (ex.ALTERA), Vicor, Microchip, Texas Instruments, Analog Devices, Mini-Circuits, Amphenol, Glenair.

Сотрудничество с глобальными дистрибьюторами электронных компонентов, предоставляет возможность заказывать и получать с международных складов практически любой перечень компонентов в оптимальные для Вас сроки.

На всех этапах разработки и производства наши партнеры могут получить квалифицированную поддержку опытных инженеров.

Система менеджмента качества компании отвечает требованиям в соответствии с ГОСТ Р ИСО 9001, ГОСТ РВ 0015-002 и ЭС РД 009

Офис по работе с юридическими лицами:

105318, г.Москва, ул.Щербаковская д.3, офис 1107, 1118, ДЦ «Щербаковский»

Телефон: +7 495 668-12-70 (многоканальный)

Факс: +7 495 668-12-70 (доб.304)

E-mail: info@moschip.ru

Skype отдела продаж:

moschip.ru

moschip.ru_4

moschip.ru_6

moschip.ru_9