



## Features

- Push switch option
- Compact, rugged design
- High reliability
- Metal bushing/shaft



# PEC11R Series - 12 mm Incremental Encoder

## Electrical Characteristics

Output.....	2-bit quadrature code
Contact Rating.....	10 mA @ 5 VDC
Insulation Resistance.....	100 megohms @ 250 VDC
Dielectric Withstanding Voltage	
Sea Level.....	300 VAC minimum
Electrical Travel.....	Continuous
Contact Bounce (15 RPM).....	2.0 ms maximum**
RPM (Operating).....	60 maximum**

## Environmental Characteristics

Operating Temperature Range.....	-30 °C to +70 °C (-22 °F to +158 °F)
Storage Temperature Range.....	-40 °C to +85 °C (-40 °F to +185 °F)
Humidity.....	MIL-STD-202, Method 103B, Condition B
Vibration.....	10~55~10 Hz / 1 min. / Amplitude 1.5 mm
Shock.....	100 G
Rotational Life.....	30,000 cycles minimum
Switch Life.....	20,000 cycles minimum
IP Rating.....	IP 40

## Mechanical Characteristics

Mechanical Angle.....	360 ° continuous
Torque	
Running.....	50 to 200 gf.cm (0.68 to 2.7 oz.-in.)
Mounting.....	10.2 kgf.cm (8.83 lb.-in.) maximum
Shaft Side Load (Static).....	2.04 kgf (4.5 lbs.) minimum
Weight.....	5 gm (0.17 oz.) maximum
Terminals.....	Printed circuit board terminals
Soldering Condition	
Wave Soldering.....	Sn95.5/Ag2.8/Cu0.7 solder with no-clean flux: 260 °C max. for 3 ±1 sec.
Hand Soldering.....	Not recommended
Hardware.....	One flat washer and one mounting nut supplied with each encoder

## Switch Characteristics

Switch Type.....	Contact Push ON Momentary SPST
Power Rating (Resistive Load).....	10 mA at 5 V DC
Switch Travel.....	0.5 ± 0.3 mm
Switch Actuation Force.....	610 ± 306 gf (8.47 ± 4.24 oz.-in.)
Contact Resistance.....	100 milliohms @ 5 VDC

## How To Order

**PEC11R - 4 0 20 F - S 0012**

Model.....	PEC11R - 4 0 20 F - S 0012
Terminal Configuration.....	4 = PC Pin Horizontal/Rear Facing
Detent Option.....	0 = No Detents (12, 18, 24 pulses) 1 = 18 Detents (18 pulses) 2 = 24 Detents (12, 24 pulses) 3 = 12 Detents (12, 24 pulses)
Standard Shaft Length.....	15 = 15.0 mm 20 = 20.0 mm 25 = 25.0 mm 30 = 30.0 mm
Shaft Style.....	F = Metal Flatted Shaft K = Metal Knurled Shaft <sup>1</sup>
Switch Configuration.....	S = Push Momentary Switch N = No Switch
Resolution.....	0012 = 12 Pulses per 360 ° Rotation 0018 = 18 Pulses per 360 ° Rotation 0024 = 24 Pulses per 360 ° Rotation

<sup>1</sup> Metal knurled shaft without switch is available in 15, 20 and 30 mm shaft lengths.  
Metal knurled shaft with push momentary switch is available in 15 and 20 mm shaft lengths.

## Quadrature Output Table



\*RoHS Directive 2002/95/EC Jan. 27, 2003 including annex and RoHS Recast 2011/65/EU June 8, 2011.

\*\*Devices are tested using standard noise reduction filters. For optimum performance, designers should use noise reduction filters in their circuits. Specifications are subject to change without notice.

The device characteristics and parameters in this data sheet can and do vary in different applications and actual device performance may vary over time. Users should verify actual device performance in their specific applications.

# Applications

Level control, tuning and timer settings in:

- Audio-visual equipment
- Consumer electric appliances
- Radios
- Musical instrumentation
- Communications equipment

## PEC11R Series - 12 mm Incremental Encoder



### Product Dimensions

#### PEC11R-4xxxF-Nxxxx



#### PEC11R-4xxxF-Sxxxx

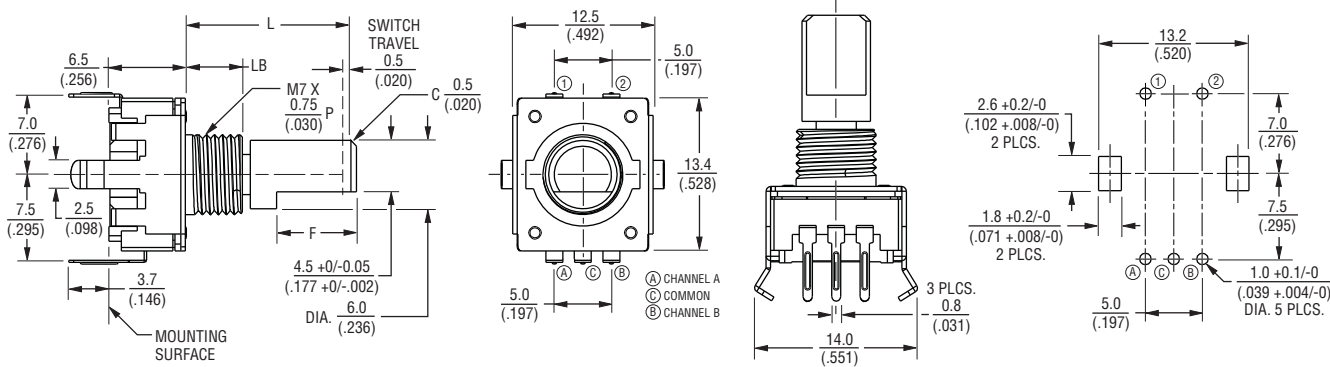

L	LB	F
15 (.591)	5.0 (.197)	7.0 (.276)
20 (.787)	7.0 (.276)	10.0 (.394)
25 (.984)	7.0 (.276)	12.0 (.472)
30 (1.181)	7.0 (.276)	12.0 (.472)

#### Switch Circuit



#### Suggested Filter Circuit



DIMENSIONS:  $\frac{MM}{(INCHES)}$

TOLERANCES:  $< \frac{10}{(.394)} = \pm \frac{0.3}{(.012)}$   
 $\geq \frac{10}{(.394)} = \pm \frac{0.5}{(.020)}$

Specifications are subject to change without notice. The device characteristics and parameters in this data sheet can and do vary in different applications and actual device performance may vary over time. Users should verify actual device performance in their specific applications.

# PEC11R Series - 12 mm Incremental Encoder

**BOURNS®**

## Product Dimensions

### PEC11R-4xxxK-Nxxxx



L	LB	P	A
15 (.591)	5.0 (.197)	7.0 (.276)	6.0 (.236)
20 (.787)	7.0 (.276)	7.0 (.276)	6.0 (.236)
30 (1.181)	7.0 (.276)	16.0 (.630)	12.0 (.472)

### PEC11R-4xxxK-Sxxxx



L	LB	P	A
15 (.591)	5.0 (.197)	7.0 (.276)	6.0 (.236)
20 (.787)	7.0 (.276)	7.0 (.276)	6.0 (.236)

DIMENSIONS:  $\frac{\text{MM}}{\text{(INCHES)}}$

TOLERANCES:  $< \frac{10}{(.394)} = \pm \frac{0.3}{(.012)}$   
 $\geq \frac{10}{(.394)} = \pm \frac{0.5}{(.020)}$

**BOURNS®**

Asia-Pacific: Tel: +886-2 2562-4117 • Fax: +886-2 2562-4116

EMEA: Tel: +36 88 520 390 • Fax: +36 88 520 211

The Americas: Tel: +1-951 781-5500 • Fax: +1-951 781-5700

[www.bourns.com](http://www.bourns.com)

REV. 07/14

Specifications are subject to change without notice.

The device characteristics and parameters in this data sheet can and do vary in different applications and actual device performance may vary over time. Users should verify actual device performance in their specific applications.

## Данный компонент на территории Российской Федерации

### Вы можете приобрести в компании MosChip.

Для оперативного оформления запроса Вам необходимо перейти по данной ссылке:

<http://moschip.ru/get-element>

Вы можете разместить у нас заказ для любого Вашего проекта, будь то серийное производство или разработка единичного прибора.

В нашем ассортименте представлены ведущие мировые производители активных и пассивных электронных компонентов.

Нашей специализацией является поставка электронной компонентной базы двойного назначения, продукции таких производителей как XILINX, Intel (ex.ALTERA), Vicor, Microchip, Texas Instruments, Analog Devices, Mini-Circuits, Amphenol, Glenair.

Сотрудничество с глобальными дистрибьюторами электронных компонентов, предоставляет возможность заказывать и получать с международных складов практически любой перечень компонентов в оптимальные для Вас сроки.

На всех этапах разработки и производства наши партнеры могут получить квалифицированную поддержку опытных инженеров.

Система менеджмента качества компании отвечает требованиям в соответствии с ГОСТ Р ИСО 9001, ГОСТ РВ 0015-002 и ЭС РД 009

### Офис по работе с юридическими лицами:

105318, г.Москва, ул.Щербаковская д.3, офис 1107, 1118, ДЦ «Щербаковский»

Телефон: +7 495 668-12-70 (многоканальный)

Факс: +7 495 668-12-70 (доб.304)

E-mail: [info@moschip.ru](mailto:info@moschip.ru)

Skype отдела продаж:

moschip.ru

moschip.ru\_4

moschip.ru\_6

moschip.ru\_9