



R120LC

DC Operated Low Cost RVIT

SPECIFICATIONS

- ◆ **Low cost**
- ◆ **5VDC supply voltage**
- ◆ **0 to 120 degree sensing range**
- ◆ **Non-contact electrical design**
- ◆ **¼ inch shaft diameter**
- ◆ **Ratiometric output**
- ◆ **No wear potentiometer replacement**
- ◆ **Light weight**

The **R120LC** RVIT (Rotary Variable Inductance Transducer) is a cost efficient, DC operated non-contact angular position sensor. It provides a smooth 0.5 to 4.5VDC output, ratiometric to the supply voltage and proportional to angular position over the 120 degree sensing range. The R120LC utilizes non-contacting, differential inductive technology, and does not suffer the wear problems experienced by potentiometers.

The R120LC proprietary design utilizes a set of four printed circuit coils and a light-weight conductive spoiler to achieve superior performance with a low moment of inertia. During operation, the light weight spoiler rotates with the transducer shaft, differentially altering the inductance of the printed circuit planar coils. The resulting unbalance is precisely measured using a patented autoplex circuit. This signal is then converted to a linear DC output voltage proportional to the angle of the rotor shaft. The digital circuit provides resistance to environmental disturbances such as EMI and RFI, and is ideally suited to the most rigorous industrial applications.

FEATURES

- ◆ Precision ball bearings
- ◆ Infinite resolution
- ◆ Low moment of inertia
- ◆ Long term reliability
- ◆ Wide operating temperature range

APPLICATIONS

- ◆ Valve position
- ◆ Fly-by-wire joy-stick position feedback
- ◆ General aviation stall warning sensor
- ◆ Potentiometer replacement

Calibrated over the full 120 degree sensing range, the R120LC offers exceptional performance at a cost effective price. It also features a wide operating temperature range, infinite resolution, and an extremely long rotational cycle life.

PERFORMANCE SPECIFICATIONS

ELECTRICAL SPECIFICATIONS	
Input voltage	5±0.25 VDC
Input current	21mA maximum
Angular range	0 to 120 degree
Non-linearity	±0.5% of FSO
Output at range ends	+0.5 to +4.5 VDC (ratiometric to input voltage)
Sensitivity	6.67mV/V/degree (ratiometric to input voltage)
Temp coefficient of output	±0.02% of FSO per °F [0.03% of FSO per °C], over operating temperature range
Output current	5mA maximum
Output impedance	1Ω maximum
Non-repeatability and hysteresis	0.1% of FRO maximum
Frequency response	200 HZ @ -3 dB
ENVIRONMENTAL AND MECHANICAL SPECIFICATIONS	
Operating temperature range	-13°F to +185°F [-25°C to 85°C]
Storage temperature range	-67°F to +257°F [-55°C to 125°C]
Mechanical angular range	360 degrees (no stops)
Bearings	ABEC 3 precision
Shaft diameter	¼ inch [6.3mm]
Torque	0.12 inch.ounce-force [8.6 gram-force.cm]
Weight	1.2oz [34gm]
Electrical connection	4 lead wires, 28 AWG , PTFE insulation, 12 inches [30cm] long
IEC 60529 rating	IP60

Notes:

All values are nominal unless otherwise noted

FSO (Full Scale Output): Largest absolute value of the outputs measured at the ends of the range

FRO (Full Range Output): Algebraic difference in outputs measured at the ends of the range

DIMENSIONS

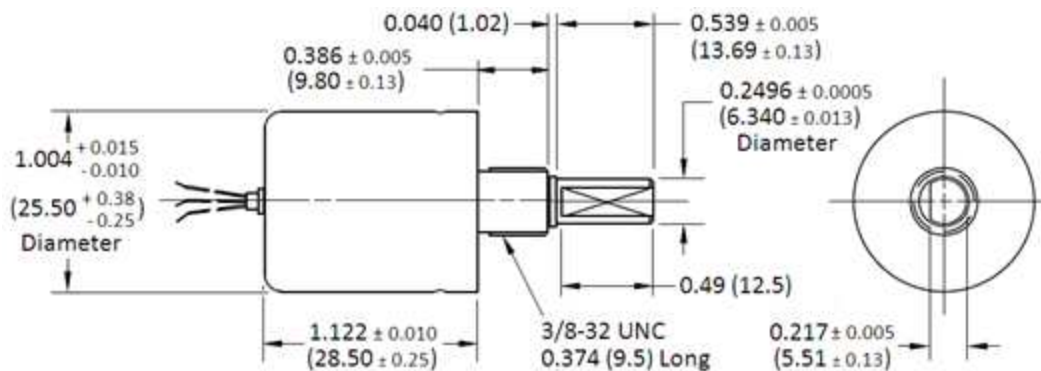

Dimensions are in inch (mm)

R120LC

DC Operated Low Cost RVIT

WIRING INFORMATION

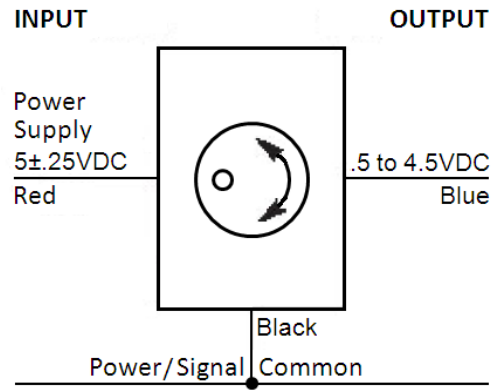

ORDERING INFORMATION

Description	Model	Part Number
RVIT 0-120°	R120LC	02183000-000

NORTH AMERICA

Measurement Specialties, Inc.,
a TE Connectivity Company
Phone +1-800-522-6752
Email: customercare.hmpt@te.com

EUROPE

MEAS Deutschland GmbH(Europe)
a TE Connectivity Company
Phone: +49-800-440-5100
Email: customercare.dtmd@te.com

ASIA

Measurement Specialties (China), Ltd.,
a TE Connectivity Company
Phone: +86-0400-820-6015
Email: customercare.shzn@te.com

TE.com/sensorsolutions

Measurement Specialties, Inc., a TE Connectivity company.

Accustar, American Sensor Technologies, AST, ATEXIS, DEUTSCH, IdentiCal, TruBlue, KPSI, Krystal Bond, Microfused, UltraStable, Measurement Specialties, MEAS, Schaevitz, TE Connectivity, TE, and the TE connectivity (logo) are trademarks of the TE Connectivity Ltd. family of companies. Other logos, product and company names mentioned herein may be trademarks of their respective owners.

The information given herein, including drawings, illustrations and schematics which are intended for illustration purposes only, is believed to be reliable. However, TE Connectivity makes no warranties as to its accuracy or completeness and disclaims any liability in connection with its use. TE Connectivity's obligations shall only be as set forth in TE Connectivity's Standard Terms and Conditions of Sale for this product and in no case will TE Connectivity be liable for any incidental, indirect or consequential damages arising out of the sale, resale, use or misuse of the product. Users of TE Connectivity products should make their own evaluation to determine the suitability of each such product for the specific application.

Данный компонент на территории Российской Федерации

Вы можете приобрести в компании MosChip.

Для оперативного оформления запроса Вам необходимо перейти по данной ссылке:

<http://moschip.ru/get-element>

Вы можете разместить у нас заказ для любого Вашего проекта, будь то серийное производство или разработка единичного прибора.

В нашем ассортименте представлены ведущие мировые производители активных и пассивных электронных компонентов.

Нашей специализацией является поставка электронной компонентной базы двойного назначения, продукции таких производителей как XILINX, Intel (ex.ALTERA), Vicor, Microchip, Texas Instruments, Analog Devices, Mini-Circuits, Amphenol, Glenair.

Сотрудничество с глобальными дистрибьюторами электронных компонентов, предоставляет возможность заказывать и получать с международных складов практически любой перечень компонентов в оптимальные для Вас сроки.

На всех этапах разработки и производства наши партнеры могут получить квалифицированную поддержку опытных инженеров.

Система менеджмента качества компании отвечает требованиям в соответствии с ГОСТ Р ИСО 9001, ГОСТ РВ 0015-002 и ЭС РД 009

Офис по работе с юридическими лицами:

105318, г.Москва, ул.Щербаковская д.3, офис 1107, 1118, ДЦ «Щербаковский»

Телефон: +7 495 668-12-70 (многоканальный)

Факс: +7 495 668-12-70 (доб.304)

E-mail: info@moschip.ru

Skype отдела продаж:

moschip.ru

moschip.ru_4

moschip.ru_6

moschip.ru_9