

GLASS SEAL PIN .012(0.30) DIA

SERIES: ACC

1 / 3

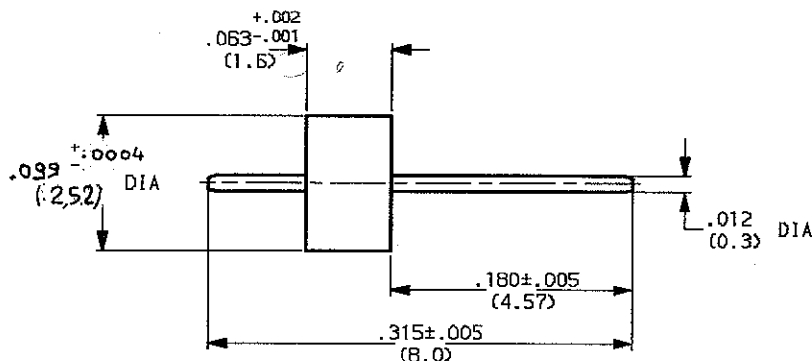

MOUNTING HOLE

See page 2 and 3.

WEIGHT 0.007 oz (0.2g)

CABLES : -

CHARACTERISTICS

NOMINAL IMPEDANCE	50 Ω
FREQUENCY RANGE	0-18 GHz
TEMPERATURE RATING	-65/+200 °C
VSWR	1.02 + 0.003 * F (GHz) Max (Applicable for mounting B (see page 3))
RF INSERTION LOSS	NA /F dB Maxi
VOLTAGE RATING	335 Vrms Maxi
DIELECTRIC WITHSTANDING VOLTAGE	1000 Vrms mini
INSULATION RESISTANCE	NA Mo mini
HERMETIC SEAL	10-8 cc/s Atm.cm3/s
LEAKAGE (pressurized only)	NA psi MPa

STANDARDISATION

CABLE RETENTION	NA lb mini N
CENTER CONTACT RETENTION	
Axial force - mating end	4.5 lb mini 20 N
Axial force - opposite end	4.5 lb mini 20 N
Torque (Min)	NA Inch.oz cm.N
RECOMMENDED TORQUES	
Mating	NA Inch.Lb cm.N
Panel nut	NA Inch.Lb cm.N
Clamp nut	NA Inch.Lb cm.N

CONSTRUCTION

CONNECTOR PARTS	MATERIALS	FINISH
BODY	-	-
OUTER CONTACT	FERRO-NICKEL	GOLD OVER NICKEL
CENTER CONTACT	FERRO-NICKEL	GOLD OVER NICKEL
INSULATORS	MATCHED GLASS	-
-	-	-
-	-	-
-	-	-
-	-	-

ISSUE	REVISION No	DESCRIPTION	BY	DATE
9731	97.05.013	$\varnothing 2.51 \rightarrow \varnothing 2.52$	(VICIARD)	28.07.97

Initiated on 06.NOV.97
Superseded on _____

The information given here is subject to change without notice. Design changes may be in order to improve the product.



SOLDER GLASS SEAL PIN .012 (0.30) DIA

SERIES: ACC

RECOMMENDED MOUNTING HOLE DETAIL

FLANGE RECEPTACLE

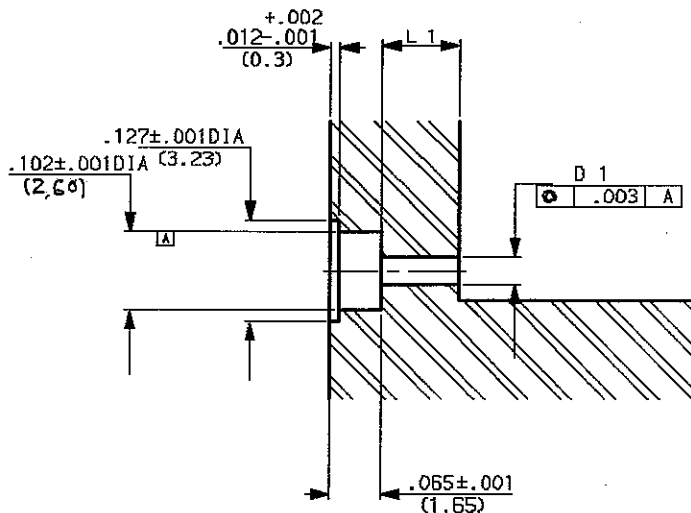

RECEPTACLE SCREW

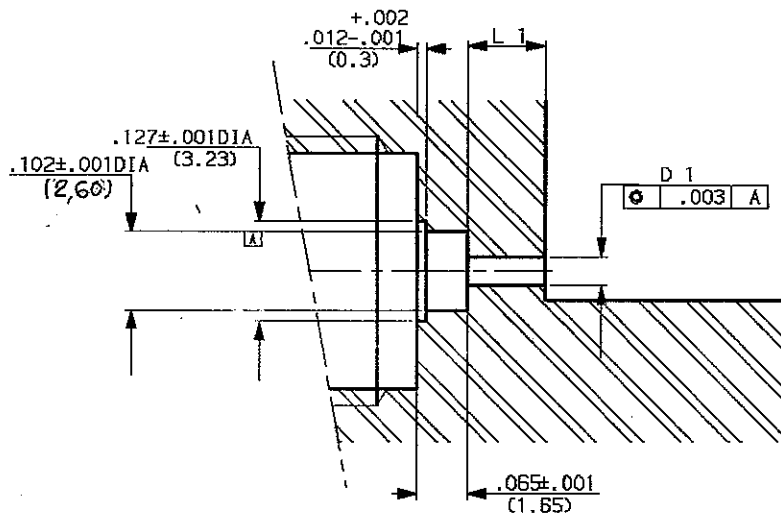

D1 and L1 dimensions have to be determined according to each application.

We advise of two following case: (see page 3)

- using of the R280 469 removable socket :

$D1 = .079 + \text{or} - .0008$

$L1 = .1 + \text{or} - .004$

- the bead pin is directly welded on the track :

$D1 = .0276 + \text{or} - .0008$

L1 = from .040 to .157 according to customer's design criteria.

ISSUE	REVISION No	DESCRIPTION	BY	DATE
9731	97.05.013	Dia 2,59 → DIA 2,60	TRIPIER	28.07.97

Initiated on 06-Nov-97

Superseded on

The information given here is subject to change without notice. Design changes may be in order to improve the product.



SOLDER GLASS SEAL PIN .012 (0.3) DIA

ASSEMBLY INSTRUCTIONS

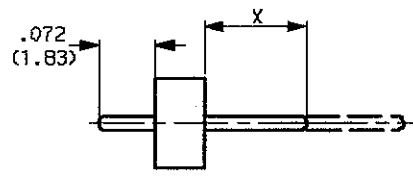

MOUNTING A: WITH REMOVABLE CONTACT

$X = .079(2) \pm .020$

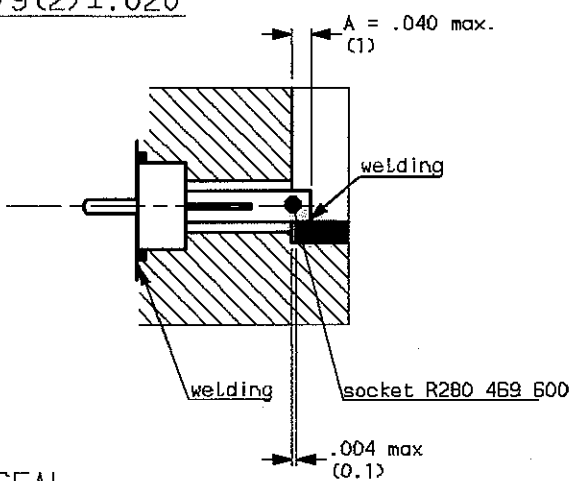

MOUNTING B: WITH SEAL ONLY

$X = L1 + A$

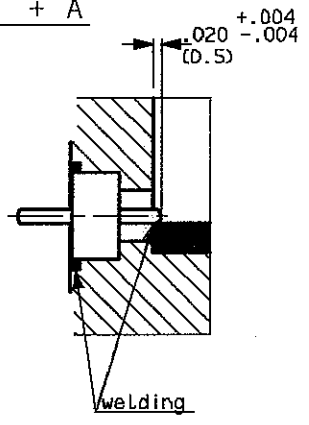

GLASS SEAL

- 1 - Adjust X by cutting the pin if necessary.
- 2 - Introduce the glass bead into its housing as here above (with the mounted socket)
- 3 - Weld the ring by putting a welding wire in the groove.
- 4 - Weld the pin (or socket) on the track. Beware of putting too much welding!

IMPORTANT: for maximum RF characteristics the Link track/pin must be as thin as possible. We advise you to respect rigorously the A dimension, by welding accurately the bead pin directly on the track (right drawing).

CONNECTOR

- FLANGE RECEPTACLE: Set up the EMI gasket in the connector groove. Put the connector on the housing while introducing the bead pin into socket, then mount the fixtures of the flange.
- SCREW RECEPTACLE: Screw the connector into the housing. (Tooling and torque, see the following board)

	TOOLING	TORQUE
<input type="checkbox"/> SMA	Jack receptacle R282.341.010 Plug receptacle R282.342	17 inch-pounds
<input type="checkbox"/> BMA	Jack receptacle R282.322 Plug receptacle R282.340	25 inch-pounds

ISSUE	REVISION No	DESCRIPTION	BY	DATE
.
.
.

Initiated on 06. NOV. 91
Superseded on -----

The information given here is subject to change without notice. Design changes may be in order to improve the product.



Данный компонент на территории Российской Федерации

Вы можете приобрести в компании MosChip.

Для оперативного оформления запроса Вам необходимо перейти по данной ссылке:

<http://moschip.ru/get-element>

Вы можете разместить у нас заказ для любого Вашего проекта, будь то серийное производство или разработка единичного прибора.

В нашем ассортименте представлены ведущие мировые производители активных и пассивных электронных компонентов.

Нашей специализацией является поставка электронной компонентной базы двойного назначения, продукции таких производителей как XILINX, Intel (ex.ALTERA), Vicor, Microchip, Texas Instruments, Analog Devices, Mini-Circuits, Amphenol, Glenair.

Сотрудничество с глобальными дистрибьюторами электронных компонентов, предоставляет возможность заказывать и получать с международных складов практически любой перечень компонентов в оптимальные для Вас сроки.

На всех этапах разработки и производства наши партнеры могут получить квалифицированную поддержку опытных инженеров.

Система менеджмента качества компании отвечает требованиям в соответствии с ГОСТ Р ИСО 9001, ГОСТ РВ 0015-002 и ЭС РД 009

Офис по работе с юридическими лицами:

105318, г.Москва, ул.Щербаковская д.3, офис 1107, 1118, ДЦ «Щербаковский»

Телефон: +7 495 668-12-70 (многоканальный)

Факс: +7 495 668-12-70 (доб.304)

E-mail: info@moschip.ru

Skype отдела продаж:

moschip.ru

moschip.ru_4

moschip.ru_6

moschip.ru_9