

REV	DOCUMENT	CHANGED BY	CHECK
8	0033839	PRS 13SEP07	CMH

SERIES
MOTOROLA HOUSING
COMPENSATED AND
CALIBRATED (mV)

PRESSURE RANGE
0.3, 01, 05, 15, 30,
60, 100, 150 PSI

ACCURACY GRADE
C - COMMERCIAL GRADE
H - HIGH GRADE

PORT OPTION
F - AXIAL
T - RADIAL
FS - OFFSET AXIAL

PRESSURE REFERENCE
G - GAGE

CATALOG LISTINGS	
XPC0.3GFSH	XPC30GFSH
⑦	XPC30GTC
XPC01GFSH	⑦
XPC01GTC	⑧
XPC01GTH	⑦
⑦	XPC100GFH
XPC15GFH	XPC100GTC
XPC05GTH	⑧
⑦	⑦
XPC15GTC	XPC150GTC
XPC30GFC	XPC150GTH
⑧	XPC60GTC
XPC30GFH	SCDA102-XPC01GTH

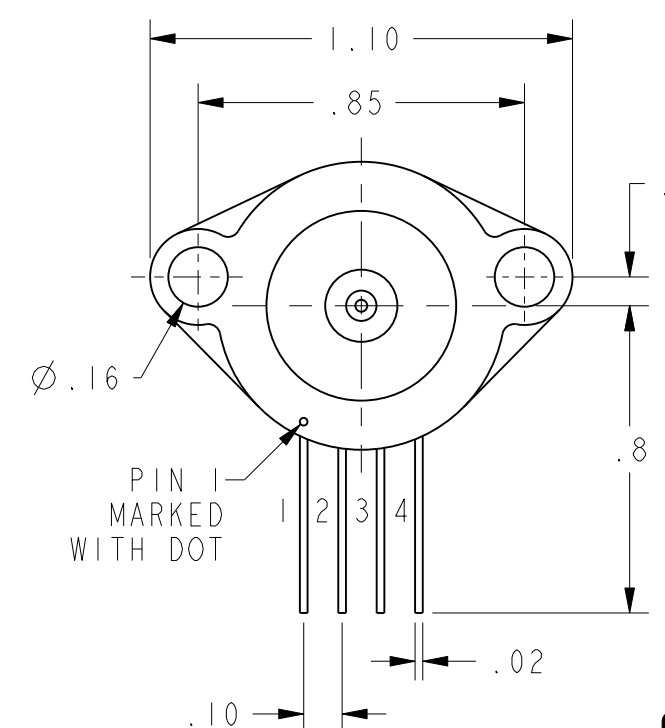

GFS HOUSING

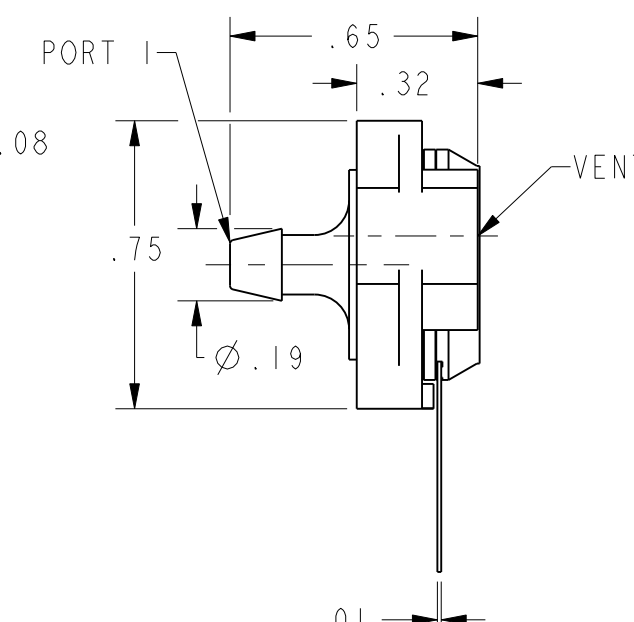

G STYLE (GAGE)	PERFORMANCE AT 25°C AND 12±0.01 VDC (UNLESS OTHERWISE STATED)						UNITS	PROOF PRESSURE PSIG	BURST PRESSURE PSIG	FULL SCALE PRESSURE PSI
	C-GRADE			H-GRADE						
	MIN	NOM	MAX	MIN	NOM	MAX				
NULL OFFSET (0 PSIG), ALL LISTINGS	---	0	±1	---	0	±.5	mV			
SPAN 0.3 PSIG (PI>VENT)	19	20	21	19.5	20	20.5	mV	3	5	
SPAN 1 PSIG (PI>VENT)	17	18	19	17.5	18	18.5	mV	3	5	
SPAN 5 PSIG (PI>VENT)	57	60	63	59	60	61	mV	15	25	
SPAN 120cm H ₂ O (SCDA102) (PI>VENT)				30	30.5	31	mV	3	5	1.707
SPAN 15 PSIG (PI>VENT)	85	90	95	89	90	91	mV	45	75	
SPAN 30 PSIG (PI>VENT)	85	90	95	89	90	91	mV	90	150	
SPAN 60 PSIG (PI>VENT)	85	90	95	89	90	91	mV	180	300	
SPAN 100 PSIG (PI>VENT)	95	100	105	99	100	101	mV	250	400	
SPAN 150 PSIG (PI>VENT)	85	90	95	89	90	91	mV	250	400	
COMBINED LINEARITY AND HYSTERESIS ³	---	0.25	1	---	0.25	0.5	%FS			
NULL SHIFT OVER TEMPERATURE (0-25, 25-70 °C)	---	---	±1	---	---	±.5	mV			
SPAN SHIFT OVER TEMPERATURE (0-25, 25-70 °C)	---	---	±2	---	---	±1	%FS			

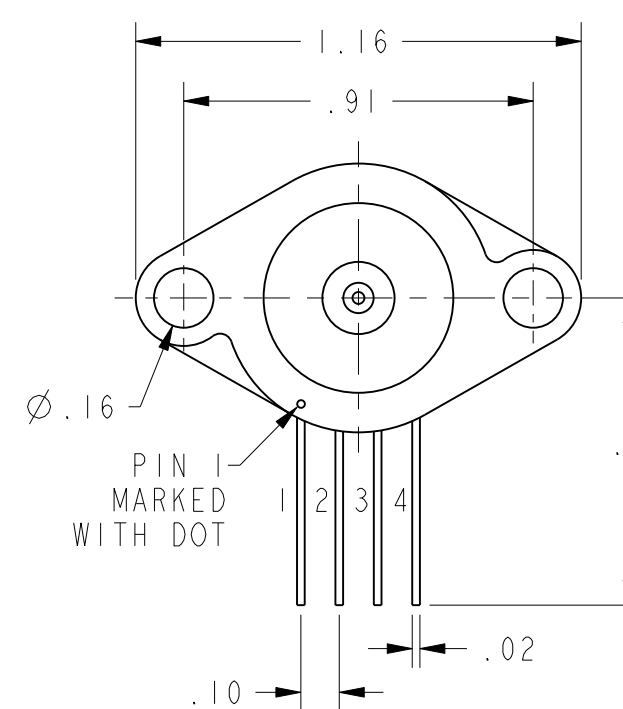

GF HOUSING

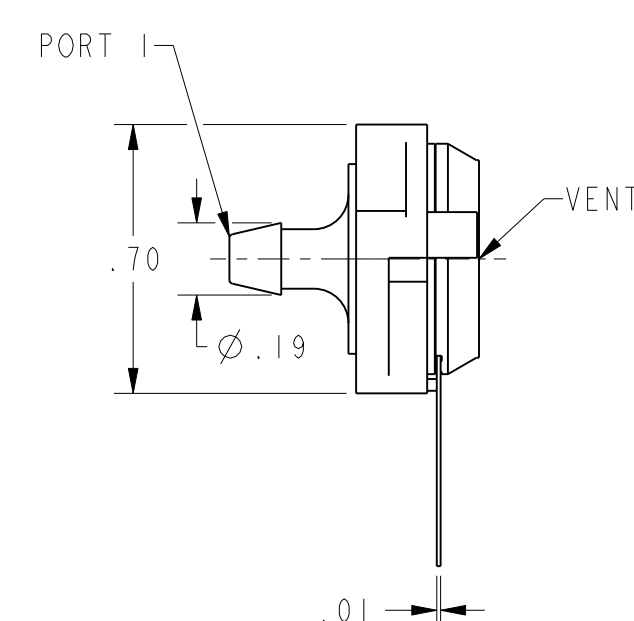

GENERAL OPERATING CHARACTERISTICS	ALL PRESSURES AND GRADES			UNITS
	MIN	NOM	MAX	
EXCITATION VOLTAGE	3	12	16	VDC
SUPPLY CURRENT	---	---	3.5	mA
INPUT RESISTANCE	5	---	---	KΩ
OUTPUT RESISTANCE	---	3	---	KΩ
OPERATING TEMPERATURE	-25	---	85	°C
STORAGE TEMPERATURE	-40	---	125	°C

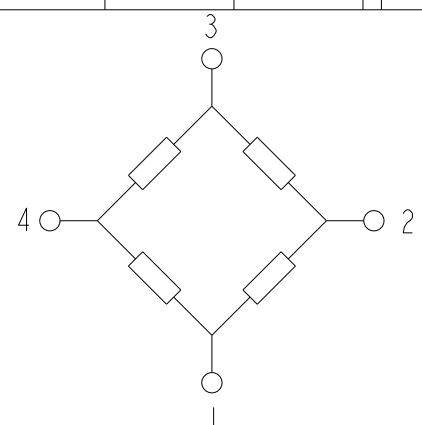

EQUIVALENT CIRCUIT

PIN OUT	
1	-V EXCITATION
2	+ OUTPUT SIGNAL
3	+ V EXCITATION
4	- OUTPUT SIGNAL

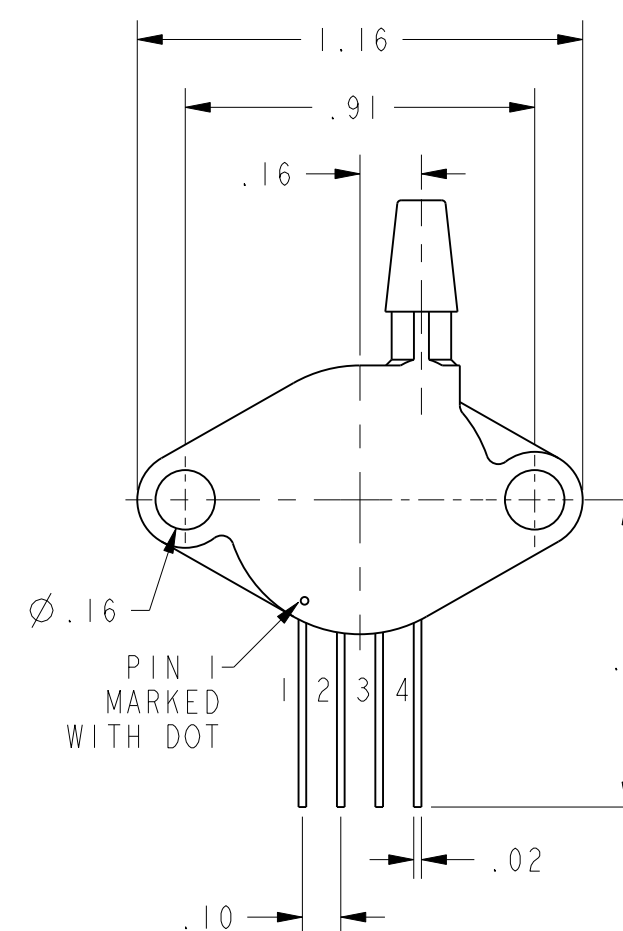

GT HOUSING

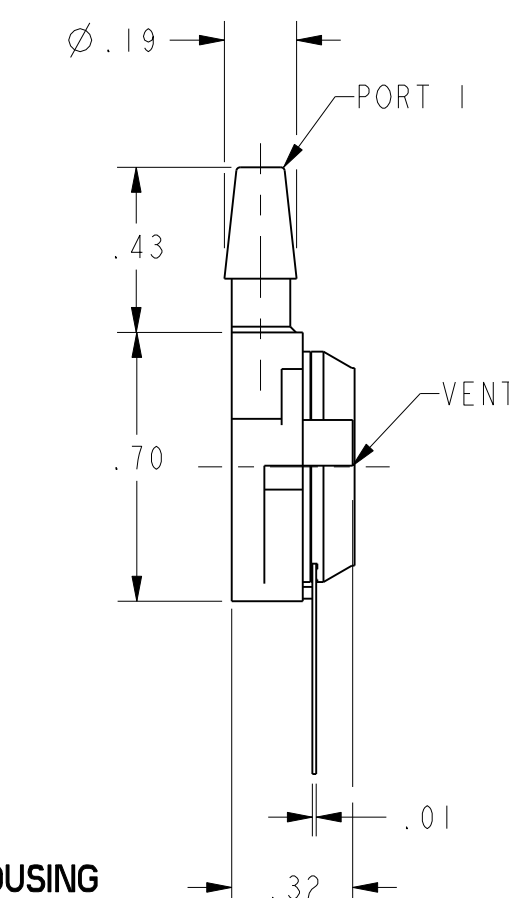

- NOTES
- SPAN IS THE ALGEBRAIC DIFFERENCE BETWEEN THE OUPUT AT MAXIMUM RATED OPERATING PRESSURE AND THE OUTPUT AT 0 PSIG
 - TEMPERATURE ERROR IS CALCULATED WITH RESPECT TO 25°C
 - LINEARITY IS MEASURED AT 1/2 FULL SCALE PRESSURE USING BEST STRAIGHT LINE FIT
 - THE OUTPUT OF THE SENSOR IS PROPORTIONAL, RATIO METRIC, TO THE EXCITATION VOLTAGE. THE EXCITATION MAY VARY BETWEEN 3 TO 16 VDC. ALL SPECIFICATIONS WILL NOMINALLY BE CHANGED BY THE RATIO OF $V_{EXCITATION}/12.0$ VDC
 - LIMIT SOLDERING TO 315°C FOR LESS THAN 10 SECONDS
 - THE DOT ON THE HOUSING IDENTIFIES TERMINAL NO. 1
 - APPLYING POSITIVE PRESSURE TO PORT NO. 1 RESULTS IN POSITIVE GOING OUPUT
 - SENSORS ARE OPERATIONAL OVER VACUUM PRESSURE RANGE
 - INPUT MEDIA RESTRICTED TO DRY GASES ONLY

UNLESS OTHERWISE SPECIFIED TOLERANCES ARE:	<input checked="" type="checkbox"/> US (inch) CUSTOMARY	<input type="checkbox"/> SI (mm) METRIC	DRAWN	TSM	16NOV00	Honeywell		
NO PLACE	X	±.040 ±1	CHECK	SAV	16NOV00			
ONE PLACE	.X	±.030 ±0.4	THIS DRAWING COVERS A PROPRIETARY ITEM AND IS THE PROPERTY OF HONEYWELL. THIS DRAWING IS NOT TO BE COPIED OR USED WITHOUT THE PERMISSION OF HONEYWELL.			TITLE		
TWO PLACE	.XX	±.015 ±0.15				SIZE	DWG TYPE	DRAWING NAME
THREE PLACE	.XXX	±.005 ±				C	I	XPC GAGE SERIES CHART 1 8
ANGLES	±	±				SCALE	2:1	WEIGHT
RAW MATERIAL-COMMERCIAL STANDARD	±	±	3D PTC	ASME Y14.5M-1994	SHEET	1 OF 1		
THIRD ANGLE PROJECTION						REV		
						8		

Данный компонент на территории Российской Федерации

Вы можете приобрести в компании MosChip.

Для оперативного оформления запроса Вам необходимо перейти по данной ссылке:

<http://moschip.ru/get-element>

Вы можете разместить у нас заказ для любого Вашего проекта, будь то серийное производство или разработка единичного прибора.

В нашем ассортименте представлены ведущие мировые производители активных и пассивных электронных компонентов.

Нашей специализацией является поставка электронной компонентной базы двойного назначения, продукции таких производителей как XILINX, Intel (ex.ALTERA), Vicor, Microchip, Texas Instruments, Analog Devices, Mini-Circuits, Amphenol, Glenair.

Сотрудничество с глобальными дистрибьюторами электронных компонентов, предоставляет возможность заказывать и получать с международных складов практически любой перечень компонентов в оптимальные для Вас сроки.

На всех этапах разработки и производства наши партнеры могут получить квалифицированную поддержку опытных инженеров.

Система менеджмента качества компании отвечает требованиям в соответствии с ГОСТ Р ИСО 9001, ГОСТ РВ 0015-002 и ЭС РД 009

Офис по работе с юридическими лицами:

105318, г.Москва, ул.Щербаковская д.3, офис 1107, 1118, ДЦ «Щербаковский»

Телефон: +7 495 668-12-70 (многоканальный)

Факс: +7 495 668-12-70 (доб.304)

E-mail: info@moschip.ru

Skype отдела продаж:

moschip.ru

moschip.ru_4

moschip.ru_6

moschip.ru_9