

EZ-Host™ Programmable Embedded USB Host and Peripheral Controller with Automotive AEC Grade Support

EZ-Host Features

- Single chip programmable USB dual-role (Host/Peripheral) controller with two configurable Serial Interface Engines (SIEs) and four USB ports
- Support for USB On-The-Go (OTG) protocol
- On-chip 48 MHz 16-bit processor with dynamically switchable clock speed
- Configurable IO block supporting a variety of IO options or up to 32 bits of General Purpose IO (GPIO)
- 4K x 16 internal masked ROM containing built in BIOS that supports a communication ready state with access to I²C™ EEPROM Interface, external ROM, UART, or USB
- 8K x 16 internal RAM for code and data buffering
- Extended memory interface port for external SRAM and ROM
- 16-bit parallel Host Port Interface (HPI) with a DMA/mailbox data path for an external processor to directly access all of the on-chip memory and control on-chip SIEs
- Fast serial port supports from 9600 baud to 2.0M baud

- SPI support in both master and slave
- On-chip 16-bit DMA/mailbox data path interface
- Supports 12 MHz external crystal or clock
- 3.3V operation
- Automotive AEC grade option (−40°C to 85°C)
- Package option—100-pin TQFP

Typical Applications

EZ-Host is a very powerful and flexible dual role USB controller that supports a wide variety of applications. It is primarily intended to enable host capability in applications such as:

- Set top boxes
- Printers
- KVM switches
- Kiosks
- Automotive applications
- Wireless access points

Block Diagram

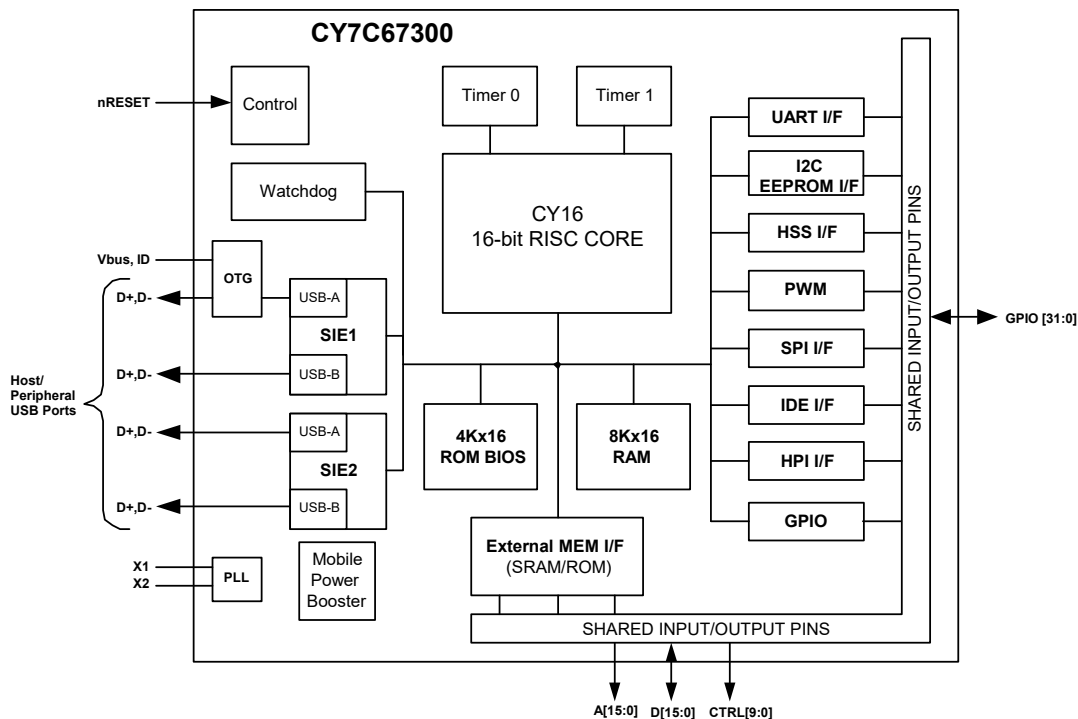

Errata: For information on silicon errata, see "Errata" on page 107. Details include trigger conditions, devices affected, and proposed workaround.

Contents

Introduction	3	HSS Registers	62
Functional Overview	3	HPI Registers	68
Processor Core	3	SPI Registers	72
Clocking	3	UART Registers	80
Memory	3	PWM Registers	82
Interrupts	3	Pin Diagram	86
General Timers and Watchdog Timer	3	Pin Descriptions	86
Power Management	3	Absolute Maximum Ratings	90
Interface Descriptions	3	Operating Conditions	90
USB Interface	5	Crystal Requirements (XTALIN, XTALOUT)	90
OTG Interface	6	DC Characteristics	90
External Memory Interface	6	USB Transceiver	91
General Purpose IO Interface (GPIO)	9	AC Timing Characteristics	92
UART Interface [3]	9	Reset Timing	92
I2C EEPROM Interface [4]	9	Clock Timing	92
Serial Peripheral Interface	9	SRAM Read Cycle ^[24]	93
High-Speed Serial Interface	10	SRAM Write Cycle ^[26]	94
Programmable Pulse/PWM Interface	10	I2C EEPROM Timing-Serial IO	95
Host Port Interface	11	HPI (Host Port Interface) Write Cycle Timing	96
IDE Interface	11	HPI (Host Port Interface) Read Cycle Timing	97
Charge Pump Interface	12	IDE Timing	98
Booster Interface	13	HSS BYTE Mode Transmit	98
Crystal Interface	13	HSS Block Mode Transmit	98
Boot Configuration Interface	14	HSS BYTE and BLOCK Mode Receive	98
Operational Modes	14	Hardware CTS/RTS Handshake	99
Power Savings and Reset Description	15	Register Summary	99
Power Saving Mode Description	15	Ordering Information	104
Sleep	15	Ordering Code Definitions	104
External (Remote) Wakeup Source	16	Package Diagram	105
Power-On-Reset Description	16	Acronyms	106
Reset Pin	16	Document Conventions	106
USB Reset	16	Units of Measure	106
Memory Map	16	Errata	107
Mapping	16	Part Numbers Affected	107
Registers	18	CY7C67300 Qualification Status	107
Processor Control Registers	18	CY7C67300 Errata Summary	107
External Memory Registers	25	Document History Page	117
Timer Registers	27	Sales, Solutions, and Legal Information	119
General USB Registers [10]	29	Worldwide Sales and Design Support	119
USB Host Only Registers [11]	32	Products	119
USB Device Only Registers	43	PSoC® Solutions	119
OTG Control Registers [13]	54	Cypress Developer Community	119
GPIO Registers	56	Technical Support	119
IDE Registers	59		

Introduction

EZ-Host™ (CY7C67300) is Cypress Semiconductor's first full-speed, low cost multiport host/peripheral controller. EZ-Host is designed to easily interface to most high performance CPUs to add USB host functionality. EZ-Host has its own 16-bit RISC processor to act as a coprocessor or operate in standalone mode. EZ-Host also has a programmable IO interface block allowing a wide range of interface options.

Functional Overview

An overview of the processor core components are presented in this section.

Processor Core

EZ-Host has a general purpose 16-bit embedded RISC processor that runs at 48 MHz.

Clocking

EZ-Host requires a 12 MHz source for clocking. Either an external crystal or TTL level oscillator may be used. EZ-Host has an internal PLL that produces a 48 MHz internal clock from the 12 MHz source.

Memory

EZ-Host has a built in 4K × 16 masked ROM and an 8K × 16 internal RAM. The masked ROM contains the EZ-Host BIOS. The internal RAM can be used for program code or data.

Interrupts

EZ-Host provides 128 interrupt vectors. The first 48 vectors are hardware interrupts and the following 80 vectors are software interrupts.

General Timers and Watchdog Timer

EZ-Host has two built in programmable timers and a Watchdog timer. All three timers can generate an interrupt to the EZ-Host.

Power Management

EZ-Host has one main power saving mode, Sleep. Sleep mode pauses all operations and provides the lowest power state.

Interface Descriptions

EZ-Host has a wide variety of interface options for connectivity. With several interface options available, EZ-Host can act as a seamless data transport between many different types of devices.

See [Table 1](#) and [Table 2 on page 4](#) to understand how the interfaces share pins and which can coexist. Note that some interfaces have more than one possible port location selectable through the GPIO control register [0xC006]. General guidelines for interfaces are as follows:

- HPI and IDE interfaces are mutually exclusive.
- If 16-bit external memory is required, then HSS and SPI default locations must be used.
- I²C EEPROM and OTG do not conflict with any interfaces.

Table 1. Interface Options for GPIO Pins

GPIO Pins	HPI	IDE	PWM	HSS	SPI	UART	I2C	OTG
GPIO31							SCL/SDA	
GPIO30							SCL/SDA	
GPIO29								OTGID
GPIO28						TX		
GPIO27						RX		
GPIO26			PWM3	CTS ^[1]				
GPIO25								
GPIO24	INT	IOREADY						
GPIO23	nRD	IOR						
GPIO22	nWR	IOW						
GPIO21	nCS							
GPIO20	A1	CS1						
GPIO19	A0	CS0						
GPIO18		A2	PWM2	RTS ^[1]				
GPIO17		A1	PWM1	RXD ^[1]				
GPIO16		A0	PWM0	TXD ^[1]				
GPIO15	D15	D15						
GPIO14	D14	D14						
GPIO13	D13	D13						
GPIO12	D12	D12						
GPIO11	D11	D11				MOSI ^[1]		
GPIO10	D10	D10				SCK ^[1]		
GPIO9	D9	D9				nSSI ^[1]		
GPIO8	D8	D8				MISO ^[1]		
GPIO7	D7	D7						
GPIO6	D6	D6						
GPIO5	D5	D5						
GPIO4	D4	D4						
GPIO3	D3	D3						
GPIO2	D2	D2						
GPIO1	D1	D1						
GPIO0	D0	D0						

Table 2. Interface Options for External Memory Bus Pins

MEM Pins	HPI	IDE	PWM	HSS	SPI	UART	I2C	OTG
D15				CTS ^[2]				
D14				RTS ^[2]				
D13				RXD ^[2]				
D12				TXD ^[2]				
D11					MOSI ^[2]			
D10					SCK ^[2]			
D9					nSSI ^[2]			
D8					MISO ^[2]			
D[7:0]								
A[18:0]								
CONTROL								

Notes

1. Default interface location.
2. Alternate interface location.

USB Interface

EZ-Host has two built in Host/Peripheral SIEs and four USB transceivers that meet the USB 2.0 specification requirements for full and low speed (high speed is not supported). In Host mode, EZ-Host supports four downstream ports, each support control, interrupt, bulk, and isochronous transfers. In Peripheral mode, EZ-Host supports one peripheral port with eight endpoints for each of the two SIEs. Endpoint 0 is dedicated as the control endpoint and only supports control transfers. Endpoints 1 through 7 support interrupt, bulk (up to 64 bytes/packet), or isochronous transfers (up to 1023 Bytes/packet size). EZ-Host also supports a combination of Host and Peripheral ports simultaneously as shown in [Table 3 on page 5](#).

Table 3. USB Port Configuration Options

Port Configurations	Port 1A	Port 1B	Port 2A	Port 2B
OTG	OTG	–	–	–
OTG + 2 Hosts	OTG	–	Host	Host
OTG + 1 Host	OTG	–	Host	–
OTG + 1 Host	OTG	–	–	Host
OTG + 1 Peripheral	OTG	–	Peripheral	–
OTG + 1 Peripheral	OTG	–	–	Peripheral
4 Hosts	Host	Host	Host	Host
3 Hosts	Any Combination of Ports			
2 Hosts	Any Combination of Ports			
1 Host	Any Port			
2 Hosts + 1 Peripheral	Host	Host	Peripheral	–
2 Hosts + 1 Peripheral	Host	Host	–	Peripheral
2 Hosts + 1 Peripheral	Peripheral	–	Host	Host
2 Hosts + 1 Peripheral	–	Peripheral	Host	Host
1 Host + 1 Peripheral	Host	–	Peripheral	–
1 Host + 1 Peripheral	Host	–	–	Peripheral
1 Host + 1 Peripheral	–	Host	–	Peripheral
1 Host + 1 Peripheral	–	Host	Peripheral	–
1 Host + 1 Peripheral	Peripheral	–	Host	–
1 Host + 1 Peripheral	Peripheral	–	–	Host
1 Host + 1 Peripheral	–	Peripheral	–	Host
1 Host + 1 Peripheral	–	Peripheral	Host	–
2 Peripherals	Peripheral	–	Peripheral	–
2 Peripherals	Peripheral	–	–	Peripheral
2 Peripherals	–	Peripheral	–	Peripheral
2 Peripherals	–	Peripheral	Peripheral	–
1 Peripheral	Any Port			

USB Features

- USB 2.0-compliant for full and low speed
- Up to four downstream USB host ports
- Up to two upstream USB peripheral ports
- Configurable endpoint buffers (pointer and length), must reside in internal RAM
- Up to eight available peripheral endpoints (one control endpoint)
- Supports control, interrupt, bulk, and isochronous transfers
- Internal DMA channels for each endpoint
- Internal pull up and pull down resistors
- Internal series termination resistors on USB data lines

USB Pins

Table 4. USB Interface Pins

Pin Name	Pin Number
DM1A	22
DP1A	23
DM1B	18
DP1B	19
DM2A	9
DP2A	10
DM2B	4
DP2B	5

OTG Interface

EZ-Host has one USB port that is compatible with the USB On-The-Go supplement to the USB 2.0 specification. The USB OTG port has a various hardware features to support Session Request Protocol (SRP) and Host Negotiation Protocol (HNP). OTG is only supported on USB PORT 1A.

OTG Features

- Internal charge pump to supply and control VBUS
- VBUS valid status (above 4.4V)
- VBUS status for $2.4V < VBUS < 0.8V$
- ID pin status
- Switchable 2K ohm internal discharge resistor on VBUS
- Switchable 500 ohm internal pull up resistor on VBUS
- Individually switchable internal pull up and pull down resistors on the USB data lines

OTG Pins

Table 5. OTG Interface Pins

Pin Name	Pin Number
DM1A	22
DP1A	23
OTGVBUS	11
OTGID	41
CSwitchA	13
CSwitchB	12

External Memory Interface

EZ-Host provides a robust interface to a wide variety of external memory arrays. All available external memory array locations can contain either code or data. The CY16 RISC processor directly addresses a flat memory space from 0x0000 to 0xFFFF.

External Memory Interface Features

- Supports 8-bit or 16-bit SRAM or ROM
- SRAM or ROM can be used for code or data space
- Direct addressing of SRAM or ROM

- Two external memory mapped page registers

External Memory Access Strobes

Access to external memory is sampled asynchronously on the rising edge of strobes with a minimum of one wait state cycle. Up to seven wait state cycles may be inserted for external memory access. Each additional wait state cycle stretches the external memory access time by 21 ns (you must be running in internal memory when changing wait states). An external memory device with 12 ns access time is necessary to support 48 MHz code execution.

Page Registers

EZ-Host allows extended data or program code to be stored in external SRAM, or ROM. The total size of extended memory can be up to 512K bytes. The CY16 processor can access extended memory via two address regions of 0x8000-0x9FFF and 0xA000-0xBFFF. The page register 0xC018 can be used to control the address region 0x8000-0x9FFF and the page register 0xC01A controls the address region of 0xA000-0xBFFF.

Figure 1 illustrates that when the nXMEMSEL pin is asserted the upper CPU address pins are driven by the contents of the Page x registers.

Figure 1. Page n Registers External Address Pins Logic

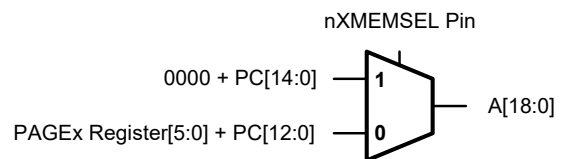

Where:
 x = 1 or 2
 PC = Program Counter
 A = CPU Address Bus

Note:
 PAGE 1 Register Active Range = 8000h to 9FFFh
 PAGE 2 Register Active Range = A000h to BFFFh
 nXMEMSEL Pin Active Range = 8000h to BFFFh

Merge Mode

Merge modes enabled through the External Memory Control register [0xC03A] allow combining of external memory regions in accordance with the following:

- nXMEMSEL is active from 0x8000 to 0xBFFF
- nXRAMSEL is active from 0x4000 to 0x7FFF when RAM Merge is disabled; nXRAMSEL is active from 0x4000 to 0xBFFF when RAM Merge is enabled
- nXROMSEL is active from 0xC100 to 0xDFFF when ROM Merge is disabled; nXROMSEL is active from 0x8000 to 0xDFFF (excluding the 0xC000 to 0xC0FF area) when ROM Merge is enabled

Program Memory Hole Description

Code residing in the 0xC000-0xC0FF address space is not accessible by the CPU.

DMA to External Memory Prohibited

EZ-Host supports an internal DMA engine to rapidly move data between different functional blocks within the chip. This DMA engine is used for SIE1, SIE2, HPI, SPI, HSS, and IDE but it can only transfer data between the specified block and internal RAM or ROM. Setting up the DMA engine to transfer to or from an external memory space might result in internal RAM data corruption because the hardware (for example, HSS/HPI/SIE1/SIE2/IDE) does not explicitly check the address range. For example, setting up a DMA transfer to external address 0x8000 might result in a DMA transfer into address 0x0000.

External Memory Related Resource Considerations:

- By default A[18:15] are not available for general addressing and are driven high on power up. The Upper Address Enable register must be written appropriately to enable A[18:15] for general addressing purposes.
- 47K ohm external pull up on pin A15 for 12 MHz crystal operation.
- During the 3 ms BIOS boot procedure the CPU external memory bus is active.
- ROM boot load value 0xC3B6 located at 0xC100.
- HPI, HSS, SPI, SIE1, SIE2, and IDE cannot DMA to external memory arrays.
- Page 1 banking is always enabled and is in effect from 0x8000 to 0x9FFF.
- Page 2 banking is always enabled and is in effect from 0xA000 to 0xBFFF.
- CPU memory bus strobes may wiggle when chip selects are inactive.

External Memory Interface Pins

Table 6. External Memory Interface Pins

Pin Name	Pin Number
nWR	64
nRD	62
nXMEMSEL (optional nCS)	34
nXROMSEL (ROM nCS)	35
nXRAMSEL (RAM nCS)	36
A18	95
A17	96
A16	97
A15	38
A14	33
A13	32
A12	31
A11	30
A10	27
A9	25
A8	24
A7	20
A6	17
A5	8
A4	7
A3	3
A2	2
A1	1
nBEL/A0	99
nBEH	98
D15	67
D14	68
D13	69
D12	70
D11	71
D10	72
D9	73
D8	74
D7	76
D6	77
D5	78
D4	79

Table 6. External Memory Interface Pins (Continued)

Pin Name	Pin Number
D3	80
D2	81
D1	82
D0	83

External Memory Interface Block Diagrams

Figure 2 illustrates how to connect a 64k × 8 memory array (SRAM/ROM) to the EZ-Host external memory interface.

Figure 2. Interfacing to 64k × 8 Memory Array

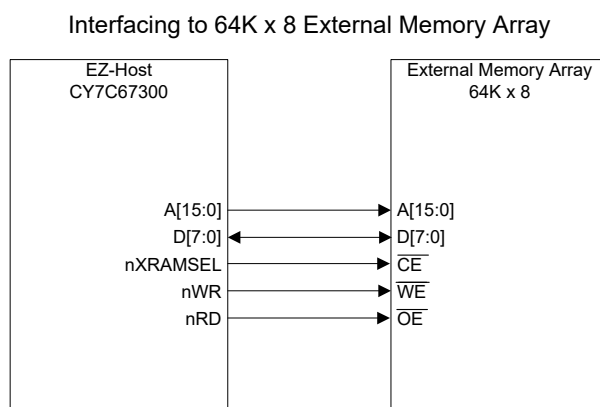

Figure 3 illustrates the interface for connecting a 16-bit ROM or 16-bit RAM to the EZ-Host external memory interface. In 16-bit mode, up to 256K words of external ROM or RAM are supported. Note that the address lines do not map directly.

Figure 3. Interfacing up to 256k × 16 for External Code/Data

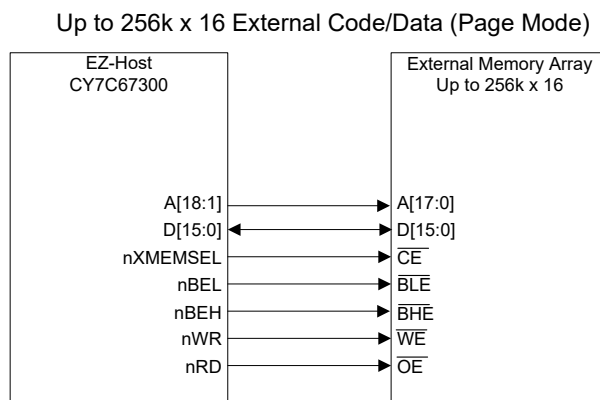
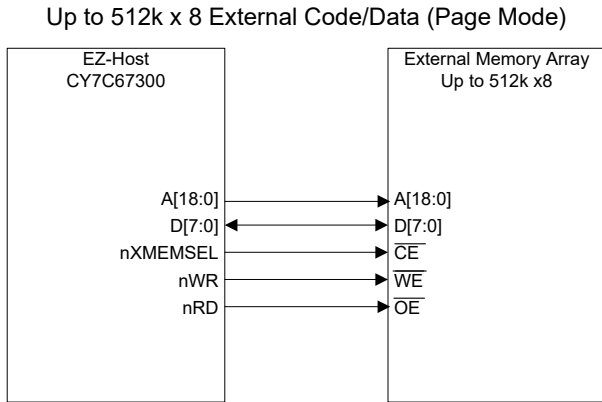

Figure 4 illustrates the interface for connecting an 8-bit ROM or 8-bit RAM to the EZ-Host external memory interface. In 8-bit mode, up to 512K bytes of external ROM or RAM are supported.

Figure 4. Interfacing up to 512k × 8 for External Code/Data



General Purpose IO Interface (GPIO)

EZ-Host has up to 32 GPIO signals available. Several other optional interfaces use GPIO pins as well and may reduce the overall number of available GPIOs.

GPIO Description

All Inputs are sampled asynchronously with state changes occurring at a rate of up to two 48 MHz clock cycles. GPIO pins are latched directly into registers, a single flip-flop.

Unused Pin Descriptions

Ensure to tristate unused USB pins with the D+ line pulled high through the internal pull up resistor and the D- line pulled low through the internal pull down resistor.

Configure unused GPIO pins as outputs so they are driven low.

UART Interface^[3]

EZ-Host has a built in UART interface. The UART interface supports data rates from 900 to 115.2K baud. It can be used as a development port or for other interface requirements. The UART interface is exposed through GPIO pins.

UART Features

- Supports baud rates of 900 to 115.2K
- 8-N-1

UART Pins.

Table 7. UART Interface Pins

Pin Name	Pin Number
TX	42
RX	43

Notes

3. **Errata:** The UART is not designed to recognize framing errors. When the UART is enabled, the GPIO Control Register still has control over GPIO 27 (UART RX pin). When enabled, the UART should override the GPIO Control Register, which defaults to setting the pin as an input. Please refer to [Errata on page 107](#) for details and workaround.
4. **Errata:** If, while the BIOS is loading firmware, the part is reset and at that time the EEPROM is driving the SDA line low, the BIOS will configure the part for co-processor mode instead of standalone mode. Please refer to [Errata on page 107](#) for details and workaround.

I²C EEPROM Interface^[4]

EZ-Host provides a master-only I²C interface for external serial EEPROMs. The serial EEPROM can be used to store application specific code and data. Use the I²C interface for loading code out of EEPROM, it is not a general I²C interface. The I²C EEPROM interface is a BIOS implementation and is exposed through GPIO pins. Refer to the BIOS documentation for additional details on this interface.

I²C EEPROM Features

- Supports EEPROMs up to 64 KB (512K bit)
- Auto-detection of EEPROM size

I²C EEPROM Pins

Table 8. I²C EEPROM Interface Pins

Pin Name	Pin Number	GPIO Number
SMALL EEPROM		
SCK	39	GPIO31
SDA	40	GPIO30
LARGE EEPROM		
SCK	40	GPIO30
SDA	39	GPIO31

Serial Peripheral Interface

EZ-Host provides a SPI interface for added connectivity. EZ-Host may be configured as either an SPI master or SPI slave. The SPI interface can be exposed through GPIO pins or the External Memory port.

SPI Features

- Master or slave mode operation
- DMA block transfer and PIO byte transfer modes
- Full duplex or half duplex data communication
- 8-byte receive FIFO and 8-byte transmit FIFO
- Selectable master SPI clock rates from 250 kHz to 12 MHz
- Selectable master SPI clock phase and polarity
- Slave SPI signaling synchronization and filtering
- Slave SPI clock rates up to 2 MHz
- Maskable interrupts for block and byte transfer modes
- Individual bit transfer for non-byte aligned serial communication in PIO mode
- Programmable delay timing for the active/inactive master SPI clock
- Auto or manual control for master mode slave select signal
- Complete access to internal memory

SPI Pins

The SPI port has a few different pin location options as shown in [Table 9](#). The port location is selectable via the GPIO control register [0xC006].

Table 9. SPI Interface Pins

Pin Name	Pin Number
Default Location	
nSSI	56 or 65
SCK	61
MOSI	60
MISO	66
Alternate Location	
nSSI	73
SCK	72
MOSI	71
MISO	74

High-Speed Serial Interface

EZ-Host provides an HSS interface. The HSS interface is a programmable serial connection with baud rate from 9600 baud to 2.0M baud. The HSS interface supports both byte and block mode operations and also hardware and software handshaking. Complete control of EZ-Host can be accomplished through this interface via an extensible API and communication protocol. The HSS interface can be exposed through GPIO pins or the External Memory port.

HSS Features

- 8 bits, no parity code
- Programmable baud rate from 9600 baud to 2M baud
- Selectable 1- or 2-stop bit on transmit
- Programmable inter-character gap timing for Block Transmit
- 8-byte receive FIFO
- Glitch filter on receive
- Block mode transfer directly to/from EZ-Host internal memory (DMA transfer)
- Selectable CTS/RTS hardware signal handshake protocol
- Selectable XON/XOFF software handshake protocol
- Programmable Receive interrupt, Block Transfer Done interrupts
- Complete access to internal memory

HSS Pins

The HSS port has a few different pin location options as shown in [Table 10](#). The port location is selectable via the GPIO control register [0xC006].

Table 10. HSS Interface Pins

Pin Name	Pin Number
Default Location	
CTS	44
RTS	53
RXD	54
TXD	55
Alternate Location	
CTS	67
RTS	68
RXD	69
TXD	70

Programmable Pulse/PWM Interface

EZ-Host has four built in PWM output channels. Each channel provides a programmable timing generator sequence that can be used to interface to various image sensors or other applications. The PWM interface is exposed through GPIO pins.

Programmable Pulse/PWM Features

- Four independent programmable waveform generators
- Programmable predefined frequencies ranging from 5.90 KHz to 48 MHz
- Configurable polarity
- Continuous and one-shot mode available

Programmable Pulse/PWM Pins.

Table 11. PWM Interface Pins

Pin Name	Pin Number
PWM3	44
PWM2	53
PWM1	54
PWM0	55

Host Port Interface

EZ-Host has an HPI interface. The HPI interface provides DMA access to the EZ-Host internal memory by an external host, plus a bidirectional mailbox register for supporting high level communication protocols. This port is designed to be the primary high-speed connection to a host processor. Complete control of EZ-Host can be accomplished through this interface via an extensible API and communication protocol. Other than the hardware communication protocols, a host processor has identical control over EZ-Host whether connecting to the HPI or HSS port. The HPI interface is exposed through GPIO pins.

HPI Features

- 16-bit data bus interface
- 16 MB/s throughput
- Auto-increment of address pointer for fast block mode transfers
- Direct memory access (DMA) to internal memory
- Bidirectional Mailbox register
- Byte swapping
- Complete access to internal memory
- Complete control of SIEs through HPI
- Dedicated HPI status register

HPI Pins

Table 12. HPI Interface Pins ^[5, 6]

Pin Name	Pin Number
INT	46
nRD	47
nWR	48
nCS	49
A1	50
A0	52
D15	56
D14	57
D13	58
D12	59

Table 12. HPI Interface Pins (Continued)^[5, 6]

D11	60
D10	61
D9	65
D8	66
D7	86
D6	87
D5	89
D4	90
D3	91
D2	92
D1	93
D0	94

The two HPI address pins are used to address one of four possible HPI port registers as shown in [Table 13](#).

Table 13. HPI Addressing

HPI A[1:0]	A1	A0
HPI Data	0	0
HPI Mailbox	0	1
HPI Address	1	0
HPI Status	1	1

IDE Interface

EZ-Host has an IDE interface. The IDE interface supports PIO mode 0-4 as specified in the Information Technology-AT Attachment-4 with Packet Interface Extension (ATA/ATAPI-4) Specification, T13/1153D Rev 18. There is no need for firmware to use programmable wait states. The CPU read/write cycle is automatically extended as needed for direct CPU to IDE read/write accesses.

The EZ-Host IDE interface also has a BLOCK transfer mode that allows EZ-Host to read/write large blocks of data to/from the IDE data register and move it to/from the EZ-Host on-chip memory directly without intervention of the CPU. The IDE interface is exposed through GPIO pins. [Table 14 on page 12](#) lists the achieved throughput for maximum block mode data transfer rate (with IDE_IORDY true) for the various IDE PIO modes.

Notes

5. HPI_INT is for the Outgoing Mailbox interrupt.
6. HPI strobes are negative logic sampled on rising edge.

Table 14. IDE Throughput

Mode	ATA/ATAPI-4 Min Cycle Time	Actual Min Cycle Time	ATA/ATAPI-4 Max Transfer Rate	Actual Max Transfer Rate
PIO Mode 0	600 ns	30T = 625 ns	3.33 MB/s	3.2 MB/s
PIO Mode 1	383 ns	20T = 416.7 ns	5.22 MB/s	4.8 MB/s
PIO Mode 2	240	13T = 270.8 ns	8.33 MB/s	7.38 MB/s
PIO Mode 3	180 ns	10T = 208.3 ns	11.11 MB/s	9.6 MB/s
PIO Mode 4	120 ns	8T = 166.7 ns	16.67 MB/s	12.0 MB/s

T = System clock period = 1/48 MHz.

IDE Features

- Programmable IO mode 0–4
- Block mode transfers
- Direct memory access to/from internal memory through the IDE data register

IDE Pins

Table 15. IDE Interface Pins

Pin Name	Pin Number
IORDY	46
IOR	47
IOW	48
CS1	50
CS0	52
A2	53
A1	54
A0	55
D15	56
D14	57
D13	58
D12	59
D11	60
D10	61
D9	65
D8	66
D7	86
D6	87
D5	89
D4	90
D3	91
D2	92
D1	93
D0	94

Charge Pump Interface

VBUS for the USB OTG port can be produced by EZ-Host using its built in charge pump and some external components. Ensure the circuit connections look similar to the following diagram.

Figure 5. Charge Pump

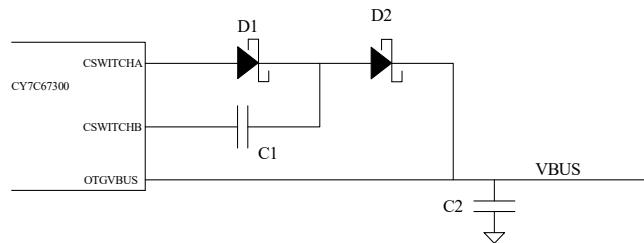

Component details:

- D1 and D2: Schottky diodes with a current rating greater than 60 mA
- C1: Ceramic capacitor with a capacitance of 0.1 μ F
- C2: Make capacitor value no more that 6.5 μ F since that is the maximum capacitance allowed by the USB OTG specifications for a dual role device. The minimum value of C2 is 1 μ F. There are no restrictions on the type of capacitor for C2.

If the VBUS charge pump circuit is not to be used, CSWITCHA, CSWITCHB, and OTGVBUS can be left unconnected.

Charge Pump Features

- Meets OTG Supplement Requirements, see [Table 134 on page 91](#) for details.

Charge Pump Pins

Table 16. Charge Pump Interface Pins

Pin Name	Pin Number
OTGVBUS	11
CSwitchA	13
CSwitchB	12

Booster Interface

EZ-Host has an on chip power booster circuit for use with power supplies that range between 2.7V and 3.6V. The booster circuit boosts the power to 3.3V nominal to supply power for the entire chip. The booster circuit requires an external inductor, diode, and capacitor. During power down mode, the circuit is disabled to save power. Figure 6 shows how to connect the booster circuit.

Figure 6. Power Supply Connection With Booster

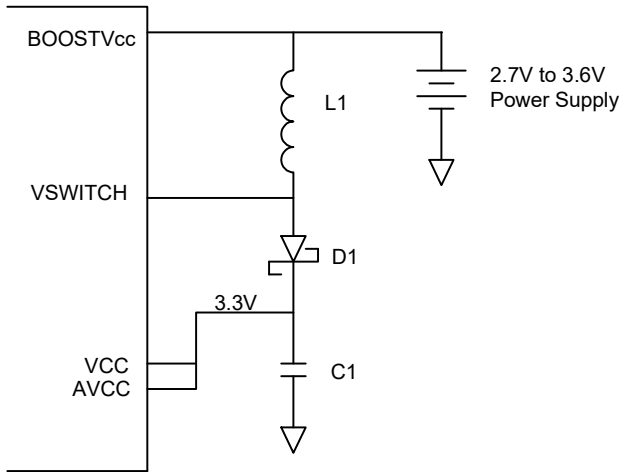

Component details:

- L1: Inductor with inductance of 10 μ H and a current rating of at least 250 mA
- D1: Schottky diode with a current rating of at least 250 mA
- C1: Tantalum or ceramic capacitor with a capacitance of at least 2.2 μ F

Figure 7 shows how to connect the power supply when the booster circuit is not being used.

Figure 7. Power Supply Connection Without Booster

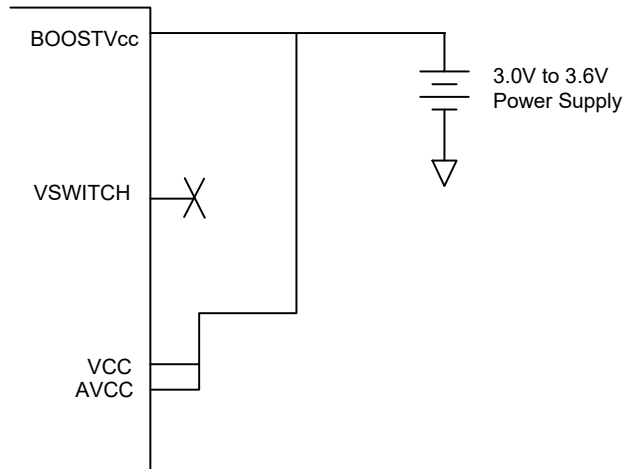

Booster Pins

Table 17. Charge Pump Interface Pins

Pin Name	Pin Number
BOOSTVcc	16
VSWITCH	14

Crystal Interface

The recommended crystal circuit to be used with EZ-Host is shown in Figure 8. If an oscillator is used instead of a crystal circuit, connect it to XTALIN and leave XTALOUT unconnected. For further information about the crystal requirements, see Table 132 on page 90.

Noted that the CLKSEL pin (pin 38) is sampled after reset to determine what crystal or clock source frequency is used. For normal operation, 12 MHz is required so the CLKSEL pin must have a 47K ohm pull up resistor to V_{CC} .

Figure 8. Crystal Interface

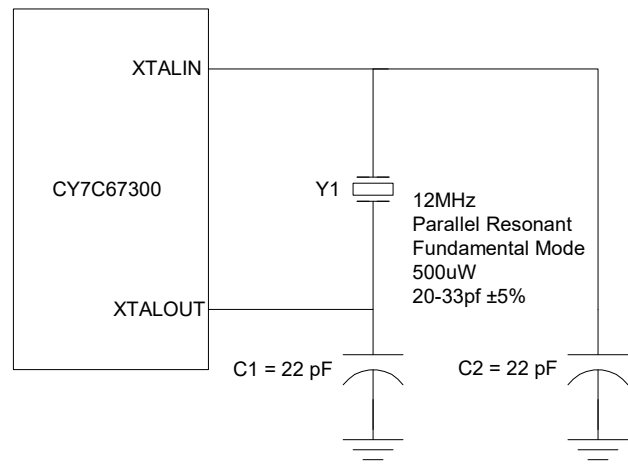

Crystal Pins

Table 18. Crystal Pins

Pin Name	Pin Number
XTALIN	29
XTALOUT	28

Boot Configuration Interface

EZ-Host can boot into any one of four modes. The mode it boots into is determined by the TTL voltage level of GPIO[31:30] at the time nRESET is deasserted. Table 19 shows the different boot pin combinations possible. After a reset pin event occurs, the BIOS bootup procedure executes for up to 3 ms. GPIO[31:30] are sampled by the BIOS during bootup only. After bootup these pins are available to the application as GPIOs.

Table 19. Boot Configuration Interface

GPIO31 (Pin 39)	GPIO30 (Pin 40)	Boot Mode
0	0	Host Port Interface (HPI)
0	1	High-Speed Serial (HSS)
1	0	Serial Peripheral Interface (SPI, slave mode)
1	1	I ² C EEPROM (Standalone Mode)

Ensure that GPIO[31:30] is pulled high or low as needed using resistors tied to V_{CC} or GND with resistor values between 5K ohms and 15K ohms. Do not tie GPIO[31:30] directly to V_{CC} or GND. Note that in standalone mode, the pull ups on those two pins are used for the serial I2C EEPROM (if implemented). Make sure that the resistors used for these pull ups conform to the serial EEPROM manufacturer's requirements.

If any mode other than standalone is chosen, EZ-Host is in coprocessor mode. The device powers up with the appropriate communication interface enabled according to its boot pins and waits idle until a coprocessor communicates with it. See the BIOS documentation for greater detail of the boot process.

Operational Modes

The operational modes are discussed in the following sections.

Coprocessor Mode

EZ-Host can act as a coprocessor to an external host processor. In this mode, an external host processor drives EZ-Host and is the main processor rather than EZ-Host's own 16-bit internal CPU. An external host processor may interface to EZ-Host through one of the following three interfaces in coprocessor mode:

- HPI mode, a 16 bit parallel interface with up to 16 MB transfer rate
- HSS mode, a serial interface with up to 2M baud transfer rate
- SPI mode, a serial interface with up to 2 Mb/s transfer rate

At bootup GPIO[31:30] determine which of these three interfaces are used for coprocessor mode. See Table 19 for details. Bootloading begins from the selected interface after POR + 3 ms of BIOS bootup.

Standalone Mode

In standalone mode, there is no external processor connected to EZ-Host. Instead, EZ-Host's own internal 16-bit CPU is the main processor and firmware is typically downloaded from an EEPROM. Optionally, firmware may also be downloaded via USB. See Table 19 for booting into standalone mode.

After booting into standalone mode (GPIO[31:30] = '11'), the following pins are affected:

- GPIO[31:30] are configured as output pins to examine the EEPROM contents
- GPIO[28:27] are enabled for debug UART mode
- GPIO[29] is configured for as OTGID for OTG applications on PORT1A
 - If OTGID is logic 1 then PORT1A (OTG) is configured as a USB peripheral
 - If OTGID is logic 0 then PORT1A (OTG) is configured as a USB host
- Ports 1B, 2A, and 2B default as USB peripheral ports
- All other pins remain INPUT pins.

Minimum Hardware Requirements for Standalone Mode – Peripheral Only

Figure 9. Minimum Standalone Hardware Configuration – Peripheral Only

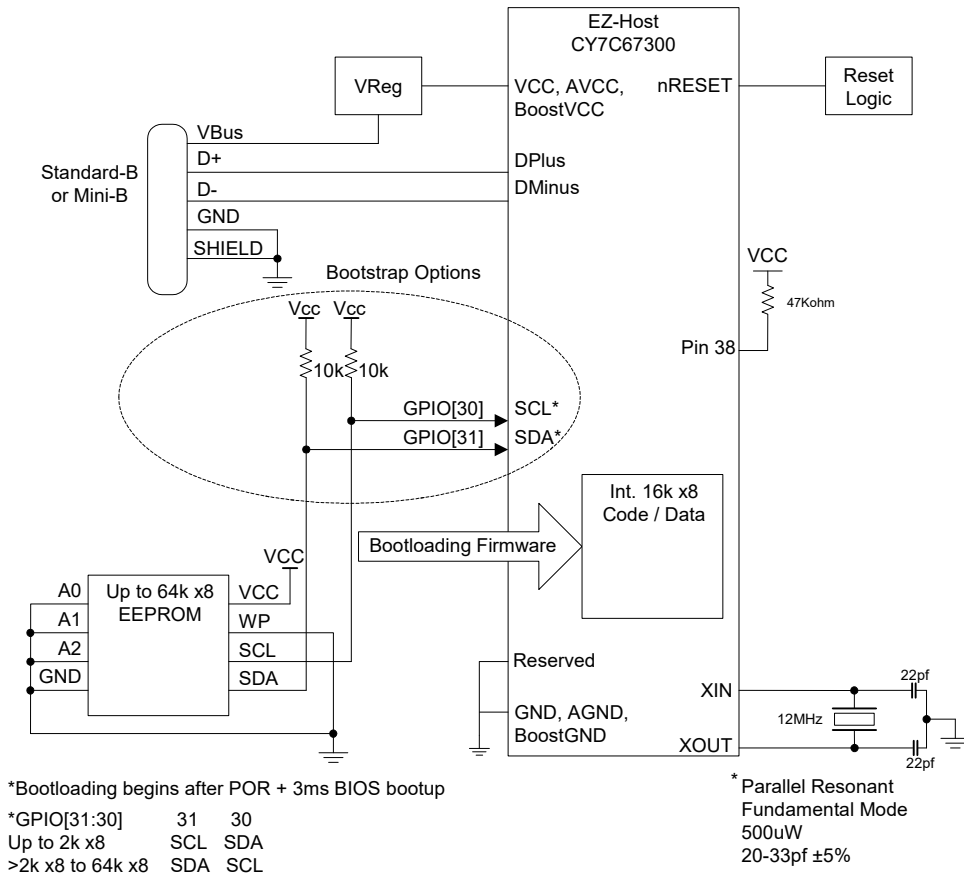

Power Savings and Reset Description

This sections describes the different modes for resetting the chip and ways to save power.

Power Saving Mode Description

EZ-Host has one main power saving mode, Sleep. For detailed information about Sleep mode, see the [Sleep](#) section that follows.

Sleep mode is used for USB applications to support USB suspend and non USB applications as the main chip power down mode.

In addition, EZ-Host is capable of slowing down the CPU clock speed through the CPU Speed register [0xC008] without affecting other peripheral timing. Reducing the CPU clock speed from 48 MHz to 24 MHz reduces the overall current draw by around 8 mA while reducing it from 48 MHz to 3 MHz reduces the overall current draw by approximately 15 mA.

Sleep

Sleep mode is the main chip power down mode and is also used for USB suspend. Sleep mode is entered by setting the Sleep Enable (bit 1) of the Power control register [0xC00A]. During Sleep mode (USB Suspend) the following events and states are true:

- GPIO pins maintain their configuration during sleep (in suspend)
- External Memory address pins are driven low
- XTALOUT is turned off
- Internal PLL is turned off
- Ensure that firmware disables the charge pump (OTG Control register [0xC098]) thereby causing OTGVBUS to drop below 0.2V. Otherwise OTGVBUS only drops to $V_{CC} - (2 \text{ schottky diode drops})$.
- Booster circuit is turned off
- USB transceivers is turned off
- CPU goes into suspend mode until a programmable wakeup event

External (Remote) Wakeup Source

There are several possible events available to wake EZ-Host from Sleep mode as shown in [Table 20](#). These may also be used as remote wakeup options for USB applications. See the [Power Control Register \[0xC00A\] \[R/W\] on page 21](#) for details.

Upon wakeup, code begins executing within 200 μ s, the time it takes the PLL to stabilize.

Table 20. Wakeup Sources ^[7, 8]

Wakeup Source (if enabled)	Event
USB Resume	D+/D- Signaling
OTGVBUS	Level
OTGID	Any Edge
HPI	Read
HSS	Read
SPI	Read
IRQ1 (GPIO 25)	Any Edge
IRQ0 (GPIO 24)	Any Edge

Power-On-Reset Description

The length of the power-on-reset event can be defined by (V_{CC} ramp to valid) + (Crystal startup). A typical application might use a 12 ms power-on-reset event = ~ 7 ms + ~ 5 ms, respectively.

Reset Pin

The Reset pin is active low and requires a minimum pulse duration of sixteen 12 MHz clock cycles (1.3 μ s). A reset event restores all registers to their default POR settings. Code execution then begins 200 μ s later at 0xFF00 with an immediate jump to 0xE000, the start of BIOS. Refer to BIOS documentation for additional details.

USB Reset

A USB Reset affects registers 0xC090 and 0xC0B0, all other registers remain unchanged.

Memory Map

The memory map is discussed in the following sections.

Mapping

The total memory space directly addressable by the CY16 processor is 64K (0x0000-0xFFFF). Program, data, and IO are contained within this 64K space. This memory space is byte addressable. [Figure 10 on page 17](#) shows the various memory region address locations.

Internal Memory

Of the internal memory, 15K bytes are allocated for user's program and data. The lower memory space from 0x0000 to 0x04A2 is reserved for interrupt vectors, general purpose registers, USB control registers, stack, and other BIOS variables. The upper internal memory space contains EZ-Host control registers from 0xC000 to 0xC0FF and the BIOS ROM itself from 0xE000 to 0xFFFF. For more information about the reserved lower memory or the BIOS ROM, refer to the Programmer's documentation and/or the BIOS documentation.

During development with the EZ-Host toolset, leave the lower area of user's space (0x04A4 to 0x1000) available to load the GDB stub. The GDB stub is required to allow the toolset debug access into EZ-Host.

The chip select pins are not active during accesses to internal memory.

External Memory

Up to 32 KB of external memory from 0x4000 - 0xBFFF is available via one chip select line (nXRAMSEL) with RAM Merge enabled (BIOS default). Additionally, another 8 KB region from 0xC100 - 0xDFFF is available via a second chip select line (nXROMSEL) giving 40 KB of total available external memory. Together with the internal 15 KB, this gives a total of either ~ 48 KB (one chip select) or ~ 56 KB (two chip selects) of available memory for either code or data.

Note that the memory map and pin names (nXRAMSEL/nXROMSEL) define specific memory regions for RAM vs. ROM. This allows the BIOS to look in the upper external memory space at 0xC100 for SCAN vectors (enabling code to be loaded/executed from ROM). If no SCAN vectors are required in the design (external memory is used exclusively for data), then all external memory regions can be used for RAM. Similarly, the external memory can be used exclusively for code space (ROM).

If more external memory is required, EZ-Host has enough address lines to support up to 512 KB. However, this requires complex code banking/paging schemes via the Extended Page registers.

For further information about setting up the external memory, see the [External Memory Interface on page 6](#).

Notes

7. Read data is discarded (dummy data).
8. HPI_INT asserts on a USB Resume.

Figure 10. Memory Map

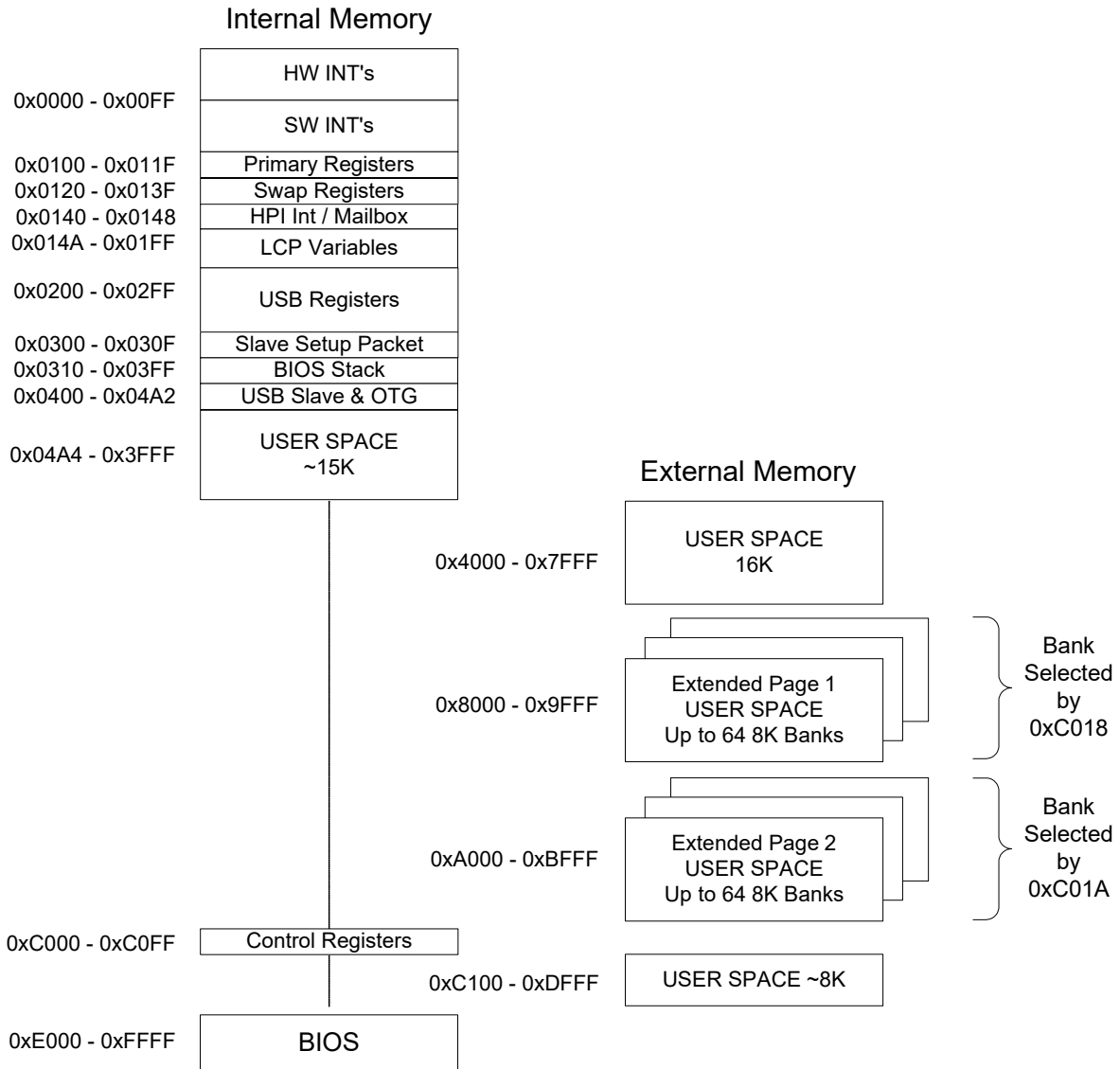

Registers

Some registers have different functions for a read vs. a write access or USB host vs. USB device mode. Therefore, registers of this type have multiple definitions for the same address.

The default register values listed in this data sheet may be altered to some other value during the BIOS initialization. Refer to the BIOS documentation for register initialization information.

Processor Control Registers

There are nine registers dedicated to general processor control. Each of these registers are covered in this section and are summarized in [Table 21](#).

Table 21. Processor Control Registers

Register Name	Address	R/W
CPU Flags Register	0xC000	R
Register Bank Register	0xC002	R/W
Hardware Revision Register	0xC004	R
CPU Speed Register	0xC008	R/W
Power Control Register	0xC00A	R/W
Interrupt Enable Register	0xC00E	R/W
Breakpoint Register	0xC014	R/W
USB Diagnostic Register	0xC03C	W
Memory Diagnostic Register	0xC03E	W

CPU Flags Register [0xC000] [R]

Table 22. CPU Flags Register

Bit #	15	14	13	12	11	10	9	8
Field	Reserved...							
Read/Write	-	-	-	-	-	-	-	-
Default	0	0	0	0	0	0	0	0

Bit #	7	6	5	4	3	2	1	0
Field	...Reserved			Global Interrupt Enable	Negative Flag	Overflow Flag	Carry Flag	Zero Flag
Read/Write	-	-	-	R	R	R	R	R
Default	0	0	0	X	X	X	X	X

Register Description

The CPU Flags register is a read only register that gives processor flags status.

Global Interrupt Enable (Bit 4)

The Global Interrupt Enable bit indicates if the Global Interrupts are enabled.

1: Enabled

0: Disabled

Negative Flag (Bit 3)

The Negative Flag bit indicates if an arithmetic operation results in a negative answer.

1: MS result bit is '1'

0: MS result bit is not '1'

Overflow Flag (Bit 2)

The Overflow Flag bit indicates if an overflow condition occurred. An overflow condition can occur if an arithmetic result was either larger than the destination operand size (for addition) or smaller than the destination operand must allow for subtraction.

1: Overflow occurred

0: Overflow did not occur

Carry Flag (Bit 1)

The Carry Flag bit indicates if an arithmetic operation resulted in a Carry for addition, or Borrow for subtraction.

1: Carry/Borrow occurred

0: Carry/Borrow did not occur

Zero Flag (Bit 0)

The Zero Flag bit indicates if an instruction execution resulted in a '0'.

1: Zero occurred

0: Zero did not occur

Bank Register [0xC002] [R/W]

Table 23. Bank Register

Bit #	15	14	13	12	11	10	9	8
Field	Address...							
Read/Write	R/W	R/W	R/W	R/W	R/W	R/W	R/W	R/W
Default	0	0	0	0	0	0	0	1
Bit #	7	6	5	4	3	2	1	0
Field	...Address			Reserved				
Read/Write	R/W	R/W	R/W	-	-	-	-	-
Default	0	0	0	X	X	X	X	X

Register Description

The Bank register maps registers R0–R15 into RAM. The eleven MSBs of this register are used as a base address for registers R0–R15. A register address is automatically generated by:

1. Shifting the four LSBs of the register address left by 1.
2. ORing the four shifted bits of the register address with the twelve MSBs of the Bank register.
3. Forcing the LSB to zero.

For example, if the Bank register is left at its default value of 0x0100, and R2 is read, then the physical address 0x0102 is read. Refer to [Table 24](#) for details.

Table 24. Bank Register Example

Register	Hex Value	Binary Value
Bank	0x0100	0000 0001 0000 0000
R14	0x000E << 1 = 0x001C	0000 0000 0001 1100
RAM Location	0x011C	0000 0001 0001 1100

Address (Bits [15:4])

The Address field is used as a base address for all register addresses to start from.

Reserved

Write all reserved bits with '0'.

Hardware Revision Register [0xC004] [R]

Table 25. Revision Register

Bit #	15	14	13	12	11	10	9	8
Field	Revision...							
Read/Write	R	R	R	R	R	R	R	R
Default	X	X	X	X	X	X	X	X
Bit #	7	6	5	4	3	2	1	0
Field	...Revision							
Read/Write	R	R	R	R	R	R	R	R
Default	X	X	X	X	X	X	X	X

Register Description

The Hardware Revision register is a read only register that indicates the silicon revision number. The first silicon revision is represented by 0x0101. This number is increased by one for each new silicon revision.

Revision (Bits [15:0])

The Revision field contains the silicon revision number.

CPU Speed Register [0xC008] [R/W]

Table 26. CPU Speed Register

Bit #	15	14	13	12	11	10	9	8
Field	Reserved...							
Read/Write	-	-	-	-	-	-	-	-
Default	0	0	0	0	0	0	0	0

Bit #	7	6	5	4	3	2	1	0
Field	...Reserved				CPU Speed			
Read/Write	-	-	-	-	R/W	R/W	R/W	R/W
Default	0	0	0	0	1	1	1	1

Register Description

The CPU Speed register allows the processor to operate at a user selected speed. This register only affects the CPU, all other peripheral timing is still based on the 48 MHz system clock (unless otherwise noted).

CPU Speed (Bits[3:0])

The CPU Speed field is a divisor that selects the operating speed of the processor as defined in [Table 27](#).

Table 27. CPU Speed Definition

CPU Speed [3:0]	Processor Speed
0000	48 MHz/1
0001	48 MHz/2
0010	48 MHz/3
0011	48 MHz/4
0100	48 MHz/5
0101	48 MHz/6
0110	48 MHz/7
0111	48 MHz/8
1000	48 MHz/9
1001	48 MHz/10
1010	48 MHz/11
1011	48 MHz/12
1100	48 MHz/13
1101	48 MHz/14
1110	48 MHz/15
1111	48 MHz/16

Reserved

Write all reserved bits with '0'.

Power Control Register [0xC00A] [R/W]

Table 28. Power Control Register

Bit #	15	14	13	12	11	10	9	8
Field	Host/Device 2B Wake Enable	Host/Device 2A Wake Enable	Host/Device 1B Wake Enable	Host/Device 1A Wake Enable	OTG Wake Enable	Reserved	HSS Wake Enable	SPI Wake Enable
Read/Write	R/W	R/W	R/W	R/W	R/W	-	R/W	R/W
Default	0	0	0	0	0	0	0	0

Bit #	7	6	5	4	3	2	1	0
Field	HPI Wake Enable	Reserved		GPI Wake Enable	Reserved	Boost 3V OK	Sleep Enable	Halt Enable
Read/Write	R/W	-	-	R/W	-	R	R/W	R/W
Default	0	0	0	0	0	0	0	0

Register Description

The Power Control register controls the power down and wakeup options. Either the sleep mode or the halt mode options can be selected. All other writable bits in this register can be used as a wakeup source while in sleep mode.

Host/Device 2B Wake Enable (Bit 15)

The Host/Device 2B Wake Enable bit enables or disables a wakeup condition to occur on a Host/Device 2B transition. This wakeup from the SIE port does not cause an interrupt to the on-chip CPU.

- 1:** Enable wakeup on Host/Device 2B transition
- 0:** Disable wakeup on Host/Device 2B transition

Host/Device 2A Wake Enable (Bit 14)

The Host/Device 2A Wake Enable bit enables or disables a wakeup condition to occur on an Host/Device 2A transition. This wakeup from the SIE port does not cause an interrupt to the on-chip CPU.

- 1:** Enable wakeup on Host/Device 2A transition
- 0:** Disable wakeup on Host/Device 2A transition

Host/Device 1B Wake Enable (Bit 13)

The Host/Device 1B Wake Enable bit enables or disables a wakeup condition to occur on an Host/Device 1B transition. This wakeup from the SIE port does not cause an interrupt to the on-chip CPU.

- 1:** Enable wakeup on Host/Device 1B transition
- 0:** Disable wakeup on Host/Device 1B transition

Host/Device 1A Wake Enable (Bit 12)

The Host/Device 1A Wake Enable bit enables or disables a wakeup condition to occur on an Host/Device 1A transition. This wakeup from the SIE port does not cause an interrupt to the on-chip CPU.

- 1:** Enable wakeup on Host/Device 1A transition
- 0:** Disable wakeup on Host/Device 1A transition

OTG Wake Enable (Bit 11)

The OTG Wake Enable bit enables or disables a wakeup condition to occur on either an OTG VBUS_Valid or OTG ID transition (IRQ20).

- 1:** Enable wakeup on OTG VBUS valid or OTG ID transition
- 0:** Disable wakeup on OTG VBUS valid or OTG ID transition

HSS Wake Enable (Bit 9)

The HSS Wake Enable bit enables or disables a wakeup condition to occur on an HSS Rx serial input transition. The processor may take several hundreds of microseconds before being operational after wakeup. Therefore, the incoming data byte that causes the wakeup is discarded.

- 1:** Enable wakeup on HSS Rx serial input transition
- 0:** Disable wakeup on HSS Rx serial input transition

SPI Wake Enable (Bit 8)

The SPI Wake Enable bit enables or disables a wakeup condition to occur on a falling SPI_nSS input transition. The processor may take several hundreds of microseconds before being operational after wakeup. Therefore, the incoming data byte that causes the wakeup is discarded.

- 1:** Enable wakeup on falling SPI nSS input transition
- 0:** Disable SPI_nSS interrupt

HPI Wake Enable (Bit 7)

The HPI Wake Enable bit enables or disables a wakeup condition to occur on an HPI interface read.

- 1:** Enable wakeup on HPI interface read
- 0:** Disable wakeup on HPI interface read

GPI Wake Enable (Bit 4)

The GPI Wake Enable bit enables or disables a wakeup condition to occur on a GPIO(25:24) transition.

- 1:** Enable wakeup on GPIO(25:24) transition
- 0:** Disable wakeup on GPIO(25:24) transition

Boost 3V OK (Bit 2)

The Boost 3V OK bit is a read only bit that returns the status of the OTG Boost circuit.

- 1: Boost circuit not ok and internal voltage rails are below 3.0V
- 0: Boost circuit ok and internal voltage rails are at or above 3.0V

Sleep Enable (Bit 1)

Setting this bit to '1' immediately initiates SLEEP mode. While in SLEEP mode, the entire chip is paused, achieving the lowest standby power state. All operations are paused, the internal clock is stopped, the booster circuit and OTG VBUS charge pump are all powered down, and the USB transceivers are powered down. All counters and timers are paused but retain their values; enabled PWM outputs freeze in their current states. SLEEP mode exits by any activity selected in this register. When SLEEP mode ends, instruction execution resumes within 0.5 ms.

- 1: Enable Sleep mode
- 0: No function

Halt Enable (Bit 0)

Setting this bit to '1' immediately initiates HALT mode. While in HALT mode, only the CPU is stopped. The internal clock still runs and all peripherals still operate, including the USB engines. The power saving using HALT in most cases is minimal, but in applications that are very CPU intensive the incremental savings may provide some benefit.

The HALT state is exited when any enabled interrupt is triggered. Upon exiting the HALT state, one or two instructions immediately following the HALT instruction may be executed before the waking interrupt is serviced (you may want to follow the HALT instruction with two NOPs).

- 1: Enable Halt mode
- 0: No function

Reserved

Write all reserved bits with '0'.

Interrupt Enable Register [0xC00E] [R/W] ^[9]

Table 29. Interrupt Enable Register

Bit #	15	14	13	12	11	10	9	8
Field	Reserved			OTG Interrupt Enable	SPI Interrupt Enable	Reserved	Host/Device 2 Interrupt Enable	Host/Device 1 Interrupt Enable
Read/Write	-	-	-	R/W	R/W	-	R/W	R/W
Default	0	0	0	0	0	0	0	0

Bit #	7	6	5	4	3	2	1	0
Field	HSS Interrupt Enable	In Mailbox Interrupt Enable	Out Mailbox Interrupt Enable	Reserved	UART Interrupt Enable	GPIO Interrupt Enable	Timer 1 Interrupt Enable	Timer 0 Interrupt Enable
Read/Write	R/W	R/W	R/W	-	R/W	R/W	R/W	R/W
Default	0	0	0	1	0	0	0	0

Register Description

The Interrupt Enable register allows control of the hardware interrupt vectors.

OTG Interrupt Enable (Bit 12)

The OTG Interrupt Enable bit enables or disables the OTG ID/OTG4.4V Valid hardware interrupt.

- 1: Enable OTG interrupt
- 0: Disable OTG interrupt

SPI Interrupt Enable (Bit 11)

The SPI Interrupt Enable bit enables or disables the following three SPI hardware interrupts: SPI TX, SPI RX, and SPI DMA Block Done.

- 1: Enable SPI interrupt
- 0: Disable SPI interrupt

Host/Device 2 Interrupt Enable (Bit 9)

The Host/Device 2 Interrupt Enable bit enables or disables all of the following Host/Device 2 hardware interrupts: Host 2 USB Done, Host 2 USB SOF/EOP, Host 2 Wakeup/Insert/Remove, Device 2 Reset, Device 2 SOF/EOP or WakeUp from USB, Device 2 Endpoint n.

- 1: Enable Host 2 and Device 2 interrupt
- 0: Disable Host 2 and Device 2 interrupt

Host/Device 1 Interrupt Enable (Bit 8)

The Host/Device 1 Interrupt Enable bit enables or disables all of the following Host/Device 1 hardware interrupts: Host 1 USB Done, Host 1 USB SOF/EOP, Host 1 Wakeup/Insert/Remove, Device 1 Reset, Device 1 SOF/EOP or WakeUp from USB, Device 1Endpoint n.

- 1: Enable Host 1 and Device 1 interrupt
- 0: Disable Host 1 and Device 1 interrupt

Note

9. **Errata:** Host/Device 1 SIE events will still trigger an interrupt when only the Host/Device 2 SIE Interrupt Enable is set and vice versa. Please refer to [Errata on page 107](#) for details and workaround.

HSS Interrupt Enable (Bit 7)

The HSS Interrupt Enable bit enables or disables the following High-speed Serial Interface hardware interrupts: HSS Block Done and HSS RX Full.

- 1: Enable HSS interrupt
- 0: Disable HSS interrupt

In Mailbox Interrupt Enable (Bit 6)

The In Mailbox Interrupt Enable bit enables or disables the HPI: Incoming Mailbox hardware interrupt.

- 1: Enable MBXI interrupt
- 0: Disable MBXI interrupt

Out Mailbox Interrupt Enable (Bit 5)

The Out Mailbox Interrupt Enable bit enables or disables the HPI: Outgoing Mailbox hardware interrupt.

- 1: Enable MBXO interrupt
- 0: Disable MBXO interrupt

UART Interrupt Enable (Bit 3)

The UART Interrupt Enable bit enables or disables the following UART hardware interrupts: UART TX, and UART RX.

- 1: Enable UART interrupt
- 0: Disable UART interrupt

GPIO Interrupt Enable (Bit 2)

The GPIO Interrupt Enable bit enables or disables the General Purpose IO pins interrupt (see the [GPIO Control Register \[0xC006\] \[R/W\] on page 56](#)). When the GPIO bit is reset, all pending GPIO interrupts are also cleared

- 1: Enable GPIO interrupt
- 0: Disable GPIO interrupt

Timer 1 Interrupt Enable (Bit 1)

The Timer 1 Interrupt Enable bit enables or disables the Tlmer1 Interrupt Enable. When this bit is reset, all pending Timer 1 interrupts are cleared.

- 1: Enable TM1 interrupt
- 0: Disable TM1 interrupt

Timer 0 Interrupt Enable (Bit 0)

The Timer 0 Interrupt Enable bit enables or disables the Tlmer0 Interrupt Enable. When this bit is reset, all pending Timer 0 interrupts are cleared.

- 1: Enable TM0 interrupt
- 0: Disable TM0 interrupt

Reserved

Write all reserved bits with '0'.

Breakpoint Register [0xC014] [R/W]

Table 30. Breakpoint Register

Bit #	15	14	13	12	11	10	9	8
Field	Address...							
Read/Write	R/W	R/W	R/W	R/W	R/W	R/W	R/W	R/W
Default	0	0	0	0	0	0	0	0

Bit #	7	6	5	4	3	2	1	0
Field	...Address							
Read/Write	R/W	R/W	R/W	R/W	R/W	R/W	R/W	R/W
Default	0	0	0	0	0	0	0	0

Register Description

The Breakpoint register holds the breakpoint address. When the program counter matches this address, the INT127 interrupt occurs. To clear this interrupt, write a zero value to this register.

Address (Bits [15:0])

The Address field is a 16-bit field containing the breakpoint address.

USB Diagnostic Register [0xC03C] [R/W]

Table 31. USB Diagnostic Register

Bit #	15	14	13	12	11	10	9	8
Field	Port 2B Diagnostic Enable	Port 2A Diagnostic Enable	Port 1B Diagnostic Enable	Port 1A Diagnostic Enable	Reserved...			
Read/Write	R/W	R/W	R/W	R/W	-	-	-	-
Default	0	0	0	0	0	0	0	0

Bit #	7	6	5	4	3	2	1	0
Field	...Reserved	Pull-down Enable	LS Pull-up Enable	FS Pull-up Enable	Reserved	Force Select		
Read/Write	-	R/W	R/W	R/W	-	R/W	R/W	R/W
Default	0	0	0	0	0	0	0	0

Register Description

The USB Diagnostic register provides control of diagnostic modes. It is intended for use by device characterization tests, not for normal operations. This register is read/write by the on-chip CPU but is write-only via the HPI port.

Port 2B Diagnostic Enable (Bit 15)

The Port 2B Diagnostic Enable bit enables or disables Port 2B for the test conditions selected in this register.

1: Apply any of the following enabled test conditions: J/K, DCK, SE0, RSF, RSL, PRD

0: Do not apply test conditions

Port 2A Diagnostic Enable (Bit 14)

The Port 2A Diagnostic Enable bit enables or disables Port 2A for the test conditions selected in this register.

1: Apply any of the following enabled test conditions: J/K, DCK, SE0, RSF, RSL, PRD

0: Do not apply test conditions

Port 1B Diagnostic Enable (Bit 13)

The Port 1B Diagnostic Enable bit enables or disables Port 1B for the test conditions selected in this register.

1: Apply any of the following enabled test conditions: J/K, DCK, SE0, RSF, RSL, PRD

0: Do not apply test conditions

Port 1A Diagnostic Enable (Bit 12)

The Port 1A Diagnostic Enable bit enables or disables Port 1A for the test conditions selected in this register.

1: Apply any of the following enabled test conditions: J/K, DCK, SE0, RSF, RSL, PRD

0: Do not apply test conditions

Pull-down Enable (Bit 6)

The Pull-down Enable bit enables or disables full-speed pull down resistors (pull down on both D+ and D-) for testing.

1: Enable pull down resistors on both D+ and D-

0: Disable pull down resistors on both D+ and D-

LS Pull-up Enable (Bit 5)

The LS Pull-up Enable bit enables or disables a low-speed pull up resistor (pull up on D-) for testing.

1: Enable low-speed pull up resistor on D-

0: Pull-up resistor is not connected on D-

FS Pull-up Enable (Bit 4)

The FS Pull-up Enable bit enables or disables a full-speed pull up resistor (pull up on D+) for testing.

1: Enable full-speed pull up resistor on D+

0: Pull up resistor is not connected on D+

Force Select (Bits [2:0])

The Force Select field bit selects several different test condition states on the data lines (D+/D-). Refer to [Table 32](#) for details.

Table 32. Force Select Definition

Force Select [2:0]	Data Line State
1xx	Assert SE0
01x	Toggle JK
001	Assert J
000	Assert K

Reserved

Write all reserved bits with '0'.

Memory Diagnostic Register [0xC03E] [W]

Table 33. Memory Diagnostic Register

Bit #	15	14	13	12	11	10	9	8
Field	Reserved					Memory Arbitration Select		
Read/Write	-	-	-	-	-	W	W	W
Default	0	0	0	0	0	0	0	0

Bit #	7	6	5	4	3	2	1	0
Field	Reserved							Monitor Enable
Read/Write	-	-	-	-	-	-	-	W
Default	0	0	0	0	0	0	0	0

Register Description

The Memory Diagnostic register provides control of diagnostic modes.

Memory Arbitration Select (Bits[10:8])

The Memory Arbitration Select field is defined in [Table 34](#).

Table 34. Memory Arbitration Select

Memory Arbitration Select [3:0]	Memory Arbitration Timing
111	1/8, 7 of every 8 cycles dead
110	2/8, 6 of every 8 cycles dead
101	3/8, 5 of every 8 cycles dead
100	4/8, 4 of every 8 cycles dead
011	5/8, 3 of every 8 cycles dead
010	6/8, 2 of every 8 cycles dead
001	7/8, 1 of every 8 cycles dead
000	8/8, all cycles available

Monitor Enable (Bit 0)

The Monitor Enable bit enables or disables monitor mode. In monitor mode the internal address bus is echoed to the external address pins.

- 1: Enable monitor mode
- 0: Disable monitor mode

Reserved

Write all reserved bits with '0'.

External Memory Registers

There are four registers dedicated to controlling the external memory interface. Each of these registers are covered in this section and are summarized in [Table 35](#).

Table 35. External Memory Control Registers

Register Name	Address	R/W
Extended Page 1 Map Register	0xC018	R/W
Extended Page 2 Map Register	0xC01A	R/W
Upper Address Enable Register	0xC038	R/W
External Memory Control Register	0xC03A	R/W

Extended Page n Map Register [R/W]

- Extended Page 1 Map Register 0xC018
- Extended Page 2 Map Register 0xC01A

Table 36. Extended Page n Map Register

Bit #	15	14	13	12	11	10	9	8
Field	Address...							
Read/Write	R/W	R/W	R/W	R/W	R/W	R/W	R/W	R/W
Default	0	0	0	0	0	0	0	0

Bit #	7	6	5	4	3	2	1	0
Field	...Address							
Read/Write	R/W	R/W	R/W	R/W	R/W	R/W	R/W	R/W
Default	0	0	0	0	0	0	0	0

Register Description

The Extended Page n Map register contains the Page n high-order address bits. These bits are always appended to accesses to the Page n Memory mapped space.

Address (Bits [15:0])

The Address field contains the high-order bits 28 to 13 of the Page n address. The address pins [8:0] (Page n address [21:13])

reflect the content of this register when the CPU accesses the address 0x8000-0x9FFF. For the SRAM mode, the address pin on [4:0] (Page n address [17:13]) is used.

Set bit [8] (Page n address [21]) to '0', so that Page n reads/writes access external areas (SRAM, ROM or peripherals). nXMEMSEL is the external chip select for this space.

Upper Address Enable Register [0xC038] [R/W]

Table 37. External Memory Control Register

Bit #	15	14	13	12	11	10	9	8
Field	Reserved							
Read/Write	-	-	-	-	-	-	-	-
Default	X	X	X	X	X	X	X	X

Bit #	7	6	5	4	3	2	1	0	
Field	Reserved				Upper Address Enable	Reserved			
Read/Write	-	-	-	-	R/W	-	-	-	
Default	X	X	X	X	0	X	X	X	

Register Description

The Upper Address Enable register enables/disables the four most significant bits of the external address A[18:15]. This register defaults to having the Upper Address disabled. Note that on power up, pins A[18:15] are driven high.

Upper Address Enable (Bit 3)

The Upper Address Enable bit enables/disables the four most significant bits of the external address A[18:15].

1: Enable A[18:15] of the external memory interface for general addressing.

0: Disable A[18:15], not available.

Reserved

Write all reserved bits with '0'.

External Memory Control Register [0xC03A] [R/W]

Table 38. External Memory Control Register

Bit #	15	14	13	12	11	10	9	8
Field	Reserved		XRAM Merge Enable	XROM Merge Enable	XMEM Width Select	XMEM Wait Select		
Read/Write	-	-	R/W	R/W	R/W	R/W	R/W	R/W
Default	X	X	X	X	X	X	X	X

Bit #	7	6	5	4	3	2	1	0
Field	XROM Width Select	XROM Wait Select			XRAM Width Select	XRAM Wait Select		
Read/Write	R/W	R/W	R/W	R/W	R/W	R/W	R/W	R/W
Default	X	X	X	X	X	X	X	X

Register Description

The External Memory Control register provides control of Wait States for the external SRAM or ROM. All wait states are based off of 48 MHz.

XRAM Merge Enable (Bit 13)

The XRAM Merge Enable bit enables or disables the RAM merge feature. When the RAM merge feature is enabled, the nXRAMSEL is active whenever the nXMEMSEL is active.

- 1: Enable RAM merge
- 0: Disable RAM merge

XROM Merge Enable (Bit 12)

The XROM Merge Enable bit enables or disables the ROM merge feature. When the ROM merge feature is enabled, the nXROMSEL is active whenever the nXMEMSEL is active.

- 1: Enable ROM merge
- 0: Disable ROM merge

XMEM Width Select (Bit 11)

The XMEM Width Select bit selects the extended memory width.

- 1: Extended memory = 8
- 0: Extended memory = 16

XMEM Wait Select (Bits [10:8])

The XMEM Wait Select field selects the extended memory wait state from 0 to 7.

XROM Width Select (Bit 7)

The XROM Width Select bit selects the external ROM width.

- 1: External memory = 8
- 0: External memory = 16

XROM Wait Select (Bits[6:4])

The XROM Wait Select field selects the external ROM wait state from 0 to 7.

XRAM Width Select (Bit 3)

The XRAM Width Select bit selects the external RAM width.

- 1: External memory = 8
- 0: External memory = 16

XRAM Wait Select (Bits[2:0])

The XRAM Wait Select field selects the external RAM wait state from 0 to 7.

Reserved

Write all reserved bits with '0'.

Timer Registers

There are three registers dedicated to timer operations. Each of these registers are discussed in this section and are summarized in [Table 39](#).

Table 39. Timer Registers

Register Name	Address	R/W
Watchdog Timer Register	0xC00C	R/W
Timer 0 Register	0xC010	R/W
Timer 1 Register	0xC012	R/W

Watchdog Timer Register [0xC00C] [R/W]

Table 40. Watchdog Timer Register

Bit #	15	14	13	12	11	10	9	8
Field	Reserved...							
Read/Write	R/W	R/W	R/W	R/W	R/W	R/W	R/W	R/W
Default	0	0	0	0	0	0	0	0

Bit #	7	6	5	4	3	2	1	0
Field	...Reserved		Timeout Flag	Period Select		Lock Enable	WDT Enable	Reset Strobe
Read/Write	R/W	R/W	R/W	R/W	R/W	R/W	R/W	W
Default	0	0	0	0	0	0	0	0

Register Description

The Watchdog Timer register provides status and control over the Watchdog timer. The Watchdog timer can also interrupt the processor.

Timeout Flag (Bit 5)

The Timeout Flag bit indicates if the Watchdog timer expired. The processor can read this bit after exiting a reset to determine if a Watchdog timeout occurred. This bit is cleared on the next external hardware reset.

1: Watchdog timer expired.

0: Watchdog timer did not expire.

Period Select (Bits [4:3])

The Period Select field is defined in [Table 41](#). If this time expires before the Reset Strobe bit is set, the internal processor is reset.

Table 41. Period Select Definition

Period Select[4:3]	WDT Period Value
00	1.4 ms
01	5.5 ms
10	22.0 ms
11	66.0 ms

Lock Enable (Bit 2)

The Lock Enable bit does not allow any writes to this register until a reset. In doing so the Watchdog timer can be set up and enabled permanently so that it can only be cleared on reset (the WDT Enable bit is ignored).

1: Watchdog timer permanently set

0: Watchdog timer not permanently set

WDT Enable (Bit 1)

The WDT Enable bit enables or disables the Watchdog timer.

1: Enable Watchdog timer operation

0: Disable Watchdog timer operation

Reset Strobe (Bit 0)

The Reset Strobe is a write-only bit that resets the Watchdog timer count. Set this bit to '1' before the count expires to avoid a Watchdog trigger

1: Reset Count

Reserved

Write all reserved bits with '0'.

Timer n Register [R/W]

- Timer 0 Register 0xC010
- Timer 1 Register 0xC012

Table 42. Timer n Register

Bit #	15	14	13	12	11	10	9	8
Field	Count...							
Read/Write	R/W	R/W	R/W	R/W	R/W	R/W	R/W	R/W
Default	1	1	1	1	1	1	1	1

Bit #	7	6	5	4	3	2	1	0
Field	...Count							
Read/Write	R/W	R/W	R/W	R/W	R/W	R/W	R/W	R/W
Default	1	1	1	1	1	1	1	1

Register Description

The Timer n Register sets the Timer n count. Both Timer 0 and Timer 1 decrement by one every 1 μ s clock tick. Each can provide an interrupt to the CPU when the timer reaches zero.

Count (Bits [15:0])

The Count field sets the Timer count.

General USB Registers ^[10]

There is one set of registers dedicated to general USB control. This set consists of two identical registers: one for Host/Device Port 1 and one for Host/Device Port 2. This register set has

functions for both USB host and USB peripheral options and is covered in this section and summarized in [Table 43](#). USB Host only registers are covered in [UART Interface \[3\] on page 9](#), and USB device only registers are covered in [External Memory Registers on page 25](#).

Table 43. General USB Registers

Register Name	Address (SIE1/SIE2)	R/W
USB n Control Register	0xC08A/0xC0AA	R/W

Note

10. Errata: Writing to the SIE2 Control register via HPI can corrupt the SIE1 Control register. Writing to the SIE1 Control register via HPI can corrupt the SIE2 Control register. Please refer to [Errata on page 107](#) for details and workaround.

USB n Control Register [R/W]

- USB 1 Control Register 0xC08A
- USB 2 Control Register 0xC0AA

Table 44. USB n Control Register

Bit #	15	14	13	12	11	10	9	8
Field	Port B D+ Status	Port B D- Status	Port A D+ Status	Port A D- Status	LOB	LOA	Mode Select	Port B Resistors Enable
Read/Write	R	R	R	R	R/W	R/W	R/W	R/W
Default	X	X	X	X	0	0	0	0

Bit #	7	6	5	4	3	2	1	0
Field	Port A Resistors Enable	Port B Force D± State		Port A Force D± State		Suspend Enable	Port B SOF/EOP Enable	Port A SOF/EOP Enable
Read/Write	R/W	R/W	R/W	R/W	R/W	R/W	R/W	R/W
Default	0	0	0	0	0	0	0	0

Register Description

The USB n Control register is used in both host and device mode. It monitors and controls the SIE and the data lines of the USB ports. This register can be accessed by the HPI interface.

Port B D+ Status (Bit 15)

The Port B D+ Status bit is a read only bit that indicates the value of DATA+ on Port B.

1: D+ is HIGH

0: D+ is LOW

Port B D– Status (Bit 14)

The Port B D– Status bit is a read only bit that indicates the value of DATA– on Port B.

1: D– is HIGH

0: D– is LOW

Port A D+ Status (Bit 13)

The Port A D+ Status bit is a read only bit that indicates the value of DATA+ on Port A.

1: D+ is HIGH

0: D+ is LOW

Port A D– Status (Bit 12)

The Port A D– Status bit is a read only bit that indicates the value of DATA– on Port A.

1: D– is HIGH

0: D– is LOW

LOB (Bit 11)

The LOB bit selects the speed of Port B.

1: Port B is set to low-speed mode

0: Port B is set to full-speed mode

LOA (Bit 10)

The LOA bit selects the speed of Port A.

1: Port A is set to low-speed mode

0: Port A is set to full-speed mode

Mode Select (Bit 9)

The Mode Select bit sets the SIE for host or device operation. When set for device operation only one USB port is supported. The active port is selected by the Port Select bit in the Host n Count register.

1: Host mode

0: Device mode

Port B Resistors Enable (Bit 8)

The Port B Resistors Enable bit enables or disables the pull up/pull down resistors on Port B. When enabled, the Mode Select bit and LOB bit of this register set the pull up/pull down resistors appropriately. When the Mode Select is set for Host mode, the pull down resistors on the data lines (D+ and D–) are enabled. When the Mode Select is set for Device mode, a single pull up resistor on either D+ or D–, determined by the LOB bit, is enabled. See [Table 45](#) for details.

1: Enable pull up/pull down resistors

0: Disable pull up/pull down resistors

Port A Resistors Enable (Bit 7)

The Port A Resistors Enable bit enables or disables the pull up/pull down resistors on Port A. When enabled, the Mode Select bit and LOA bit of this register set the pull up/pull down resistors appropriately. When the Mode Select is set for Host mode, the pull down resistors on the data lines (D+ and D–) are enabled.

When the Mode Select is set for Device mode, a single pull up resistor on either D+ or D–, determined by the LOA bit, is enabled. See [Table 45](#) for details.

1: Enable pull up/pull down resistors

0: Disable pull up/pull down resistors

Table 45. USB Data Line Pull Up and Pull Down Resistors

LOA/LOB	Mode Select	Port n Resistors Enable	Function
X	X	0	Pull up/Pull down on D+ and D– Disabled
X	1	1	Pull down on D+ and D– Enabled
1	0	1	Pull up on USB D– Enabled
0	0	1	Pull up on USB D+ Enabled

Port B Force D± State (Bits [6:5])

The Port B Force D± State field controls the forcing state of the D+ D– data lines for Port B. This field forces the state of the Port B data lines independent of the Port Select bit setting. See [Table 46](#) for details.

Port A Force D± State (Bits [4:3])

The Port A Force D± State field controls the forcing state of the D+ D– data lines for Port A. This field forces the state of the Port A data lines independent of the Port Select bit setting. See [Table 46](#) for details.

Table 46. Port A/B Force D± State

Port A/B Force D± State		Function
MSb	LSb	
0	0	Normal Operation
1	0	Force USB Reset, SE0 State
0	1	Force J-State
1	1	Force K-State

Suspend Enable (Bit 2)

The Suspend Enable bit enables or disables the suspend feature on both ports. When suspend is enabled the USB transceivers are powered down and cannot transmit or received USB packets but can still monitor for a wakeup condition.

1: Enable suspend

0: Disable suspend

Port B SOF/EOP Enable (Bit 1)

The Port B SOF/EOP Enable bit is only applicable in host mode. In device mode, this bit must be written as '0'. In host mode this bit enables or disables SOFs or EOPs for Port B. Either SOFs or EOPs are generated depending on the LOB bit in the USB n Control register when Port B is active.

1: Enable SOFs or EOPs

0: Disable SOFs or EOPs

Port A SOF/EOP Enable (Bit 0)

The Port A SOF/EOP Enable bit is only applicable in host mode. In device mode this bit must be written as '0'. In host mode this bit enables or disables SOFs or EOPs for Port A. Either SOFs or EOPs are generated depending on the LOA bit in the USB n Control register when Port A is active.

1: Enable SOFs or EOPs

0: Disable SOFs or EOPs

Reserved

Write all reserved bits with '0'.

USB Host Only Registers ^[11]

There are twelve sets of dedicated registers for USB host only operation. Each set consists of two identical registers (unless otherwise noted), one for Host Port 1 and one for Host Port 2. These register sets are covered in this section and summarized in [Table 47](#).

Table 47. USB Host Only Register

Register Name	Address (Host 1/Host 2)	R/W
Host n Control Register	0xC080/0xC0A0	R/W
Host n Address Register	0xC082/0xC0A2	R/W
Host n Count Register	0xC084/0xC0A4	R/W
Host n Endpoint Status Register	0xC086/0xC0A6	R
Host n PID Register	0xC086/0xC0A6	W
Host n Count Result Register	0xC088/0xC0A8	R
Host n Device Address Register	0xC088/0xC0A8	W
Host n Interrupt Enable Register	0xC08C/0xC0AC	R/W
Host n Status Register	0xC090/0xC0B0	R/W
Host n SOF/EOP Count Register	0xC092/0xC0B2	R/W
Host n SOF/EOP Counter Register	0xC094/0xC0B4	R
Host n Frame Register	0xC096/0xC0B6	R

Note

11. Errata: The VBUS interrupt in the Host/Device Status Registers [0xC090 and 0xC0B0] triggers multiple times whenever VBUS is turned on. It should only trigger once when VBUS rises above 4.4V and once when VBUS falls from above 4.4V to 0V. Please refer to [Errata on page 107](#) for details and workaround.

Host n Control Register [R/W]

- Host 1 Control Register 0xC080
- Host 2 Control Register 0xC0A0

Table 48. Host n Control Register

Bit #	15	14	13	12	11	10	9	8
Field	Reserved							
Read/Write	-	-	-	-	-	-	-	-
Default	0	0	0	0	0	0	0	0

Bit #	7	6	5	4	3	2	1	0
Field	Preamble Enable	Sequence Select	Sync Enable	ISO Enable	Reserved			Arm Enable
Read/Write	R/W	R/W	R/W	R/W	-	-	-	R/W
Default	0	0	0	0	0	0	0	0

Register Description

The Host n Control register allows high level USB transaction control.

Preamble Enable (Bit 7)

The Preamble Enable bit enables or disables the transmission of a preamble packet before all low-speed packets. Set this bit only when communicating with a low-speed device.

- 1:** Enable Preamble packet
- 0:** Disable Preamble packet

Sequence Select (Bit 6)

The Sequence Select bit sets the data toggle for the next packet. This bit has no effect on receiving data packets; sequence checking must be handled in firmware.

- 1:** Send DATA1
- 0:** Send DATA0

Sync Enable (Bit 5)

The Sync Enable bit synchronizes the transfer with the SOF packet in full-speed mode and the EOP packet in low-speed mode.

1: The next enabled packet is transferred after the SOF or EOP packet is transmitted

0: The next enabled packet is transferred as soon as the SIE is free

ISO Enable (Bit 4)

The ISO Enable bit enables or disables an isochronous transaction.

- 1:** Enable isochronous transaction
- 0:** Disable isochronous transaction

Arm Enable (Bit 0)

The Arm Enable bit arms an endpoint and starts a transaction. This bit is automatically cleared to '0' when a transaction is complete.

- 1:** Arm endpoint and begin transaction
- 0:** Endpoint disarmed

Reserved

Write all reserved bits with '0'.

Host n Address Register [R/W]

- Host 1 Address Register 0xC082
- Host 2 Address Register 0xC0A2

Table 49. Host n Address Register

Bit #	15	14	13	12	11	10	9	8
Field	Address...							
Read/Write	R/W	R/W	R/W	R/W	R/W	R/W	R/W	R/W
Default	0	0	0	0	0	0	0	0

Bit #	7	6	5	4	3	2	1	0
Field	...Address							
Read/Write	R/W	R/W	R/W	R/W	R/W	R/W	R/W	R/W
Default	0	0	0	0	0	0	0	0

Register Description

The Host n Address register is used as the base pointer into memory space for the current host transactions.

Address (Bits [15:0])

The Address field sets the address pointer into internal RAM or ROM.

Host n Count Register [R/W]

- Host 1 Count Register 0xC084.
- Host 2 Count Register 0xC0A4.

Table 50. Host n Count Register

Bit #	15	14	13	12	11	10	9	8
Field	Reserved	Port Select	Reserved				Count...	
Read/Write	-	R/W	-	-	-	-	R/W	R/W
Default	0	0	0	0	0	0	0	0

Bit #	7	6	5	4	3	2	1	0
Field	...Count							
Read/Write	R/W	R/W	R/W	R/W	R/W	R/W	R/W	R/W
Default	0	0	0	0	0	0	0	0

Register Description

The Host n Count register is used to hold the number of bytes (packet length) for the current transaction. The maximum packet length is 1023 bytes in ISO mode. The Host Count value is used to determine how many bytes to transmit, or the maximum number of bytes to receive. If the number of received bytes is greater than the Host Count value then an overflow condition is flagged by the Overflow bit in the Host n Endpoint Status register.

Port Select (Bit 14)

The Port Select bit selects which of the two active ports is selected and is summarized in [Table 51](#).

- 1: Port 1B or Port 2B is enabled
- 0: Port 1A or Port 2A is enabled

Table 51. Port Select Definition

Port Select	Host/Device 1 Active Port	Host/Device 2 Active Port
0	A	A
1	B	B

Count (Bits [9:0])

The Count field sets the value for the current transaction data packet length. This value is retained when switching between host and device mode, and back again.

Reserved

Write all reserved bits with '0'.

Host n Endpoint Status Register [R]

- Host 1 Endpoint Status Register 0xC086
- Host 2 Endpoint Status Register 0xC0A6

Table 52. Host n Endpoint Status Register

Bit #	15	14	13	12	11	10	9	8
Field	Reserved				Overflow Flag	Underflow Flag	Reserved	
Read/Write	-	-	-	-	R	R	-	-
Default	0	0	0	0	0	0	0	0

Bit #	7	6	5	4	3	2	1	0
Field	Stall Flag	NAK Flag	Length Exception Flag	Reserved	Sequence Status	Timeout Flag	Error Flag	ACK Flag
Read/Write	R	R	R	-	R	R	R	R
Default	0	0	0	0	0	0	0	0

Register Description

The Host n Endpoint Status register is a read only register that provides status for the last USB transaction.

Overflow Flag (Bit 11)

The Overflow Flag bit indicates that the received data in the last data transaction exceeded the maximum length specified in the Host n Count register. The Overflow Flag must be checked in response to a Length Exception signified by the Length Exception Flag set to '1'.

- 1: Overflow condition occurred
- 0: Overflow condition did not occur

Underflow Flag (Bit 10)

The Underflow Flag bit indicates that the received data in the last data transaction was less than the maximum length specified in the Host n Count register. The Underflow Flag must be checked in response to a Length Exception signified by the Length Exception Flag set to '1'.

- 1: Underflow condition occurred
- 0: Underflow condition did not occur

Stall Flag (Bit 7)

The Stall Flag bit indicates that the peripheral device replied with a Stall in the last transaction.

- 1: Device returned Stall
- 0: Device did not return Stall

NAK Flag (Bit 6)

The NAK Flag bit indicates that the peripheral device replied with a NAK in the last transaction.

- 1: Device returned NAK
- 0: Device did not return NAK

Length Exception Flag (Bit 5)

The Length Exception Flag bit indicates that the received data in the data stage of the last transaction does not equal the maximum Host Count specified in the Host n Count register. A Length Exception can either mean an overflow or underflow and the Overflow and Underflow flags (bits 11 and 10, respectively) must be checked to determine which event occurred.

- 1: An overflow or underflow condition occurred
- 0: An overflow or underflow condition did not occur

Sequence Status (Bit 3)

The Sequence Status bit indicates the state of the last received data toggle from the device. Firmware is responsible for monitoring and handling the sequence status. The Sequence bit is only valid if the ACK bit is set to '1'. The Sequence bit is set to '0' when an error is detected in the transaction and the Error bit is set.

- 1: DATA1
- 0: DATA0

Timeout Flag (Bit 2)

The Timeout Flag bit indicates if a timeout condition occurred for the last transaction. A timeout condition can occur when a device either takes too long to respond to a USB host request or takes too long to respond with a handshake.

- 1: Timeout occurred
- 0: Timeout did not occur

Error Flag (Bit 1)

The Error Flag bit indicates a transaction failed for any reason other than the following: timeout, receiving a NAK, or receiving a STALL. Overflow and Underflow are not considered errors and do not affect this bit. CRC5 and CRC16 errors result in an Error flag along with receiving incorrect packet types.

- 1: Error detected
- 0: No error detected

ACK Flag (Bit 0)

The ACK Flag bit indicates two different conditions depending on the transfer type. For non-isochronous transfers, this bit represents a transaction ending by receiving or sending an ACK packet. For isochronous transfers, this bit represents a successful transaction that is not represented by an ACK packet.

1: For non-isochronous transfers, the transaction was ACKed. For isochronous transfers, the transaction was completed successfully

0: For non-isochronous transfers, the transaction was not ACKed. For isochronous transfers, the transaction did not complete successfully

Host n PID Register [W]

■ Host 1 PID Register 0xC086

■ Host 2 PID Register 0xC0A6

Table 53. Host n PID Register

Bit #	15	14	13	12	11	10	9	8
Field	Reserved							
Read/Write	-	-	-	-	-	-	-	-
Default	0	0	0	0	0	0	0	0

Bit #	7	6	5	4	3	2	1	0
Field	PID Select				Endpoint Select			
Read/Write	W	W	W	W	W	W	W	W
Default	0	0	0	0	0	0	0	0

Register Description

The Host n PID register is a write only register that provides the PID and Endpoint information to the USB SIE to be used in the next transaction.

PID Select (Bits [7:4])

The PID Select field is defined in [Table 54](#). ACK and NAK tokens are automatically sent based on settings in the Host n Control register and do not need to be written in this register.

Endpoint Select (Bits [3:0])

The Endpoint field allows addressing of up to 16 different endpoints.

Reserved

Write all reserved bits with '0'.

Table 54. PID Select Definition

PID TYPE	PID Select [7:4]
SETUP	1101 (D Hex)
IN	1001 (9 Hex)
OUT	0001 (1 Hex)
SOF	0101 (5 Hex)
PREAMBLE	1100 (C Hex)
NAK	1010 (A Hex)
STALL	1110 (E Hex)
DATA0	0011 (3 Hex)
DATA1	1011 (B Hex)

Host n Count Result Register [R]

- Host 1 Count Result Register 0xC088
- Host 2 Count Result Register 0xC0A8

Table 55. Host n Count Result Register

Bit #	15	14	13	12	11	10	9	8
Field	Result...							
Read/Write	R	R	R	R	R	R	R	R
Default	0	0	0	0	0	0	0	0

Bit #	7	6	5	4	3	2	1	0
Field	...Result							
Read/Write	R	R	R	R	R	R	R	R
Default	0	0	0	0	0	0	0	0

Register Description

The Host n Count Result register is a read only register that contains the size difference in bytes between the Host Count Value specified in the Host n Count register and the last packet received. If an overflow or underflow condition occurs, that is the received packet length differs from the value specified in the Host n Count register, the Length Exception Flag bit in the Host n Endpoint Status register is set. The value in this register is only valid when the Length Exception Flag bit is set and the Error Flag bit is not set, both bits are in the Host n Endpoint Status register.

Result (Bits [15:0])

The Result field contains the differences in bytes between the received packet and the value specified in the Host n Count register. If an overflow condition occurs, Result [15:10] is set to '111111', a 2's complement value indicating the additional byte count of the received packet. If an underflow condition occurs, Result [15:0] indicates the excess bytes count (number of bytes not used).

Reserved

Write all reserved bits with '0'.

Host n Device Address Register [W]

- Host 1 Device Address Register 0xC088
- Host 2 Device Address Register 0xC0A8

Table 56. Host n Device Address Register

Bit #	15	14	13	12	11	10	9	8
Field	Reserved...							
Read/Write	-	-	-	-	-	-	-	-
Default	0	0	0	0	0	0	0	0

Bit #	7	6	5	4	3	2	1	0
Field	...Reserved	Address						
Read/Write	-	W	W	W	W	W	W	W
Default	0	0	0	0	0	0	0	0

Register Description

The Host n Device Address register is a write only register that contains the USB Device Address that the host wants to communicate with.

Address (Bits [6:0])

The Address field contains the value of the USB address for the next device that the host is going to communicate with. This value must be written by firmware.

Reserved

Write all reserved bits with '0'.

Host n Interrupt Enable Register [R/W]

- Host 1 Interrupt Enable Register 0xC08C
- Host 2 Interrupt Enable Register 0xC0AC

Table 57. Host n Interrupt Enable Register

Bit #	15	14	13	12	11	10	9	8
Field	VBUS Interrupt Enable	ID Interrupt Enable	Reserved				SOF/EOP Interrupt Enable	Reserved
Read/Write	R/W	R/W	-	-	-	-	R/W	-
Default	0	0	0	0	0	0	0	0

Bit #	7	6	5	4	3	2	1	0
Field	Port B Wake Interrupt Enable	Port A Wake Interrupt Enable	Port B Connect Change Interrupt Enable	Port A Connect Change Interrupt Enable	Reserved			Done Interrupt Enable
Read/Write	R/W	R/W	R/W	R/W	-	-	-	R/W
Default	0	0	0	0	0	0	0	0

Register Description

The Host n Interrupt Enable register enables control over host related interrupts.

In this register a bit set to '1' enables the corresponding interrupt while '0' disables the interrupt.

VBUS Interrupt Enable (Bit 15)

The VBUS Interrupt Enable bit enables or disables the OTG VBUS interrupt. When enabled this interrupt triggers on both the rising and falling edge of VBUS at the 4.4V status (only supported in Port 1A). This bit is only available for Host 1 and is a reserved bit in Host 2.

- 1: Enable VBUS interrupt
- 0: Disable VBUS interrupt

ID Interrupt Enable (Bit 14)

The ID Interrupt Enable bit enables or disables the OTG ID interrupt. When enabled this interrupt triggers on both the rising and falling edge of the OTG ID pin (only supported in Port 1A). This bit is only available for Host 1 and is a reserved bit in Host 2.

- 1: Enable ID interrupt
- 0: Disable ID interrupt

SOF/EOP Interrupt Enable (Bit 9)

The SOF/EOP Interrupt Enable bit enables or disables the SOF/EOP timer interrupt

- 1: Enable SOF/EOP timer interrupt
- 0: Disable SOF/EOP timer interrupt

Port B Wake Interrupt Enable (Bit 7)

The Port B Wake Interrupt Enable bit enables or disables the remote wakeup interrupt for Port B

- 1: Enable remote wakeup interrupt for Port B

- 0: Disable remote wakeup interrupt for Port B

Port A Wake Interrupt Enable (Bit 6)

The Port A Wake Interrupt Enable bit enables or disables the remote wakeup interrupt for Port A

- 1: Enable remote wakeup interrupt for Port A
- 0: Disable remote wakeup interrupt for Port A

Port B Connect Change Interrupt Enable (Bit 5)

The Port B Connect Change Interrupt Enable bit enables or disables the Port B Connect Change interrupt on Port B. This interrupt triggers when either a device is inserted (SE0 state to J state) or a device is removed (J state to SE0 state).

- 1: Enable Connect Change interrupt
- 0: Disable Connect Change interrupt

Port A Connect Change Interrupt Enable (Bit 4)

The Port A Connect Change Interrupt Enable bit enables or disables the Connect Change interrupt on Port A. This interrupt triggers when either a device is inserted (SE0 state to J state) or a device is removed (J state to SE0 state).

- 1: Enable Connect Change interrupt
- 0: Disable Connect Change interrupt

Done Interrupt Enable (Bit 0)

The Done Interrupt Enable bit enables or disables the USB Transfer Done interrupt. The USB Transfer Done triggers when either the host responds with an ACK, or a device responds with any of the following: ACK, NAK, STALL, or Timeout. This interrupt is used for both Port A and Port B.

- 1: Enable USB Transfer Done interrupt
- 0: Disable USB Transfer Done interrupt

Reserved

Write all reserved bits with '0'.

Host n Status Register [R/W]

- Host 1 Status Register 0xC090
- Host 2 Status Register 0xC0B0

Table 58. Host n Status Register

Bit #	15	14	13	12	11	10	9	8
Field	VBUS Interrupt Flag	ID Interrupt Flag	Reserved				SOF/EOP Interrupt Flag	Reserved
Read/Write	R/W	R/W	-	-	-	-	R/W	-
Default	X	X	X	X	X	X	X	X

Bit #	7	6	5	4	3	2	1	0
Field	Port B Wake Interrupt Flag	Port A Wake Interrupt Flag	Port B Connect Change Interrupt Flag	Port A Connect Change Interrupt Flag	Port B SE0 Status	Port A SE0 Status	Reserved	Done Interrupt Flag
Read/Write	R/W	R/W	R/W	R/W	R/W	R/W	-	R/W
Default	X	X	X	X	X	X	X	X

Register Description

The Host n Status register provides status information for host operation. Pending interrupts can be cleared by writing a ‘1’ to the corresponding bit. This register can be accessed by the HPI interface.

VBUS Interrupt Flag (Bit 15)

The VBUS Interrupt Flag bit indicates the status of the OTG VBUS interrupt (only for Port 1A). When enabled this interrupt triggers on both the rising and falling edge of VBUS at 4.4V. This bit is only available for Host 1 and is a reserved bit in Host 2.

- 1: Interrupt triggered
- 0: Interrupt did not trigger

ID Interrupt Flag (Bit 14)

The ID Interrupt Flag bit indicates the status of the OTG ID interrupt (only for Port 1A). When enabled this interrupt triggers on both the rising and falling edge of the OTG ID pin. This bit is only available for Host 1 and is a reserved bit in Host 2.

- 1: Interrupt triggered
- 0: Interrupt did not trigger

SOF/EOP Interrupt Flag (Bit 9)

The SOF/EOP Interrupt Flag bit indicates the status of the SOF/EOP Timer interrupt. This bit triggers ‘1’ when the SOF/EOP timer expires.

- 1: Interrupt triggered
- 0: Interrupt did not trigger

Port B Wake Interrupt Flag (Bit 7)

The Port B Wake Interrupt Flag bit indicates remote wakeup on PortB.

- 1: Interrupt triggered
- 0: Interrupt did not trigger

Port A Wake Interrupt Flag (Bit 6)

The Port A Wake Interrupt Flag bit indicates remote wakeup on PortA.

- 1: Interrupt triggered
- 0: Interrupt did not trigger

Port B Connect Change Interrupt Flag (Bit 5)

The Port B Connect Change Interrupt Flag bit indicates the status of the Connect Change interrupt on Port B. This bit triggers ‘1’ on either a rising edge or falling edge of a USB Reset condition (device inserted or removed). Together with the Port B SE0 Status bit, it can be determined whether a device was inserted or removed.

- 1: Interrupt triggered
- 0: Interrupt did not trigger

Port A Connect Change Interrupt Flag (Bit 4)

The Port A Connect Change Interrupt Flag bit indicates the status of the Connect Change interrupt on Port A. This bit triggers ‘1’ on either a rising edge or falling edge of a USB Reset condition (device inserted or removed). Together with the Port A SE0 Status bit, it can be determined whether a device was inserted or removed.

- 1: Interrupt triggered
- 0: Interrupt did not trigger

Port B SE0 Status (Bit 3)

The Port B SE0 Status bit indicates if Port B is in a SE0 state or not. Together with the Port B Connect Change Interrupt Flag bit, it can be determined whether a device was inserted (non-SE0 condition) or removed (SE0 condition).

- 1: SE0 condition
- 0: Non-SE0 condition

Port A SE0 Status (Bit 2)

The Port A SE0 Status bit indicates if Port A is in a SE0 state or not. Together with the Port A Connect change Interrupt Flag bit, it can be determined whether a device was inserted (non-SE0 condition) or removed (SE0 condition).

- 1: SE0 condition
- 0: Non-SE0 condition

Done Interrupt Flag (Bit 0)

The Done Interrupt Flag bit indicates the status of the USB Transfer Done interrupt. The USB Transfer Done triggers when either the host responds with an ACK, or a device responds with any of the following: ACK, NAK, STALL, or Timeout. This interrupt is used for both Port A and Port B.

- 1: Interrupt triggered
- 0: Interrupt did not trigger

Host n SOF/EOP Count Register [R/W]

- Host 1 SOF/EOP Count Register 0xC092
- Host 2 SOF/EOP Count Register 0xC0B2

Table 59. Host n SOF/EOP Count Register

Bit #	15	14	13	12	11	10	9	8
Field	Reserved		Count...					
Read/Write	-	-	R/W	R/W	R/W	R/W	R/W	R/W
Default	0	0	1	0	1	1	1	0

Bit #	7	6	5	4	3	2	1	0
Field	...Count							
Read/Write	R/W	R/W	R/W	R/W	R/W	R/W	R/W	R/W
Default	1	1	1	0	0	0	0	0

Register Description

The Host n SOF/EOP Count register contains the SOF/EOP Count Value that is loaded into the SOF/EOP counter. This value is loaded each time the SOF/EOP counter counts down to zero. The default value set in this register at power up is 0x2EE0 which generates a 1 ms time frame. The SOF/EOP counter is a down counter decremented at a 12 MHz rate. When this register is

read, the value returned is the programmed SOF/EOP count value.

Count (Bits [13:0])

The Count field sets the SOF/EOP counter duration.

Reserved

Write all reserved bits with '0'.

Host n SOF/EOP Counter Register [R]

- Host 1 SOF/EOP Counter Register 0xC094
- Host 2 SOF/EOP Counter Register 0xC0B4

Table 60. Host n SOF/EOP Counter Register

Bit #	15	14	13	12	11	10	9	8
Field	Reserved		Counter...					
Read/Write	-	-	R	R	R	R	R	R
Default	X	X	X	X	X	X	X	X

Bit #	7	6	5	4	3	2	1	0
Field	...Counter							
Read/Write	R	R	R	R	R	R	R	R
Default	X	X	X	X	X	X	X	X

Register Description

The Host n SOF/EOP Counter register contains the current value of the SOF/EOP down counter. This value can be used to determine the time remaining in the current frame.

Counter (Bits [13:0])

The Counter field contains the current value of the SOF/EOP down counter.

Host n Frame Register [R]

- Host 1 Frame Register 0xC096
- Host 2 Frame Register 0xC0B6

Table 61. Host n Frame Register

Bit #	15	14	13	12	11	10	9	8
Field	Reserved					Frame...		
Read/Write	-	-	-	-	-	R	R	R
Default	0	0	0	0	0	0	0	0

Bit #	7	6	5	4	3	2	1	0
Field	...Frame							
Read/Write	R	R	R	R	R	R	R	R
Default	0	0	0	0	0	0	0	0

Register Description

The Host n Frame register maintains the next frame number to be transmitted (current frame number + 1). This value is updated after each SOF transmission. This register resets to 0x0000 after each CPU write to the Host n SOF/EOP Count register (Host 1: 0xC092 Host 2: 0xC0B2).

Frame (Bits [10:0])

The Frame field contains the next frame number to be transmitted.

Reserved

Write all reserved bits with '0'.

USB Device Only Registers

There are eleven sets of USB Device Only registers. All sets consist of at least two registers, one for Device Port 1 and one for Device Port 2. In addition, each Device port has eight possible endpoints. This gives each endpoint register set eight registers for each Device Port for a total of sixteen registers per set. The USB Device Only registers are covered in this section and summarized in Table 62.

Table 62. USB Device Only Registers

Register Name	Address (Device 1/Device 2)	R/W
Device n Endpoint n Control Register	0x02n0	R/W
Device n Endpoint n Address Register	0x02n2	R/W
Device n Endpoint n Count Register	0x02n4	R/W
Device n Endpoint n Status Register	0x02n6	R/W
Device n Endpoint n Count Result Register	0x02n8	R/W
Device n Port Select Register	0xC084/0xC0A4	R/W
Device n Interrupt Enable Register	0xC08C/0xC0AC	R/W
Device n Address Register	0xC08E/0xC0AE	R/W
Device n Status Register	0xC090/0xCB0	R/W
Device n Frame Number Register	0xC092/0xC0B2	R
Device n SOF/EOP Count Register	0xC094/0xC0B4	W

Device n Endpoint n Control Register [R/W]

- Device n Endpoint 0 Control Register [Device 1: 0x0200 Device 2: 0x0280]
- Device n Endpoint 1 Control Register [Device 1: 0x0210 Device 2: 0x0290]
- Device n Endpoint 2 Control Register [Device 1: 0x0220 Device 2: 0x02A0]
- Device n Endpoint 3 Control Register [Device 1: 0x0230 Device 2: 0x02B0]
- Device n Endpoint 4 Control Register [Device 1: 0x0240 Device 2: 0x02C0]
- Device n Endpoint 5 Control Register [Device 1: 0x0250 Device 2: 0x02D0]
- Device n Endpoint 6 Control Register [Device 1: 0x0260 Device 2: 0x02E0]
- Device n Endpoint 7 Control Register [Device 1: 0x0270 Device 2: 0x02F0]

Table 63. Device n Endpoint n Control Register

Bit #	15	14	13	12	11	10	9	8
Field	Reserved							
Read/Write	-	-	-	-	-	-	-	-
Default	X	X	X	X	X	X	X	X

Bit #	7	6	5	4	3	2	1	0
Field	IN/OUT Ignore Enable	Sequence Select	Stall Enable	ISO Enable	NAK Interrupt Enable	Direction Select	Enable	Arm Enable
Read/Write	R/W	R/W	R/W	R/W	R/W	R/W	R/W	R/W
Default	X	X	X	X	X	X	X	X

Register Description

The Device n Endpoint n Control register provides control over a single EP in device mode. There are a total of eight endpoints for each of the two ports. All endpoints have the same definition for their Device n Endpoint n Control register.

IN/OUT Ignore Enable (Bit 7)

The IN/OUT Ignore Enable bit forces endpoint 0 (EP0) to ignore all IN and OUT requests. Set this bit so that EP0 only accepts Setup packets at the start of each transfer. Clear this bit to accept IN/OUT transactions. This bit only applies to EP0.

- 1: Ignore IN/OUT requests
- 0: Do not ignore IN/OUT requests

Sequence Select (Bit 6)

The Sequence Select bit determines whether a DATA0 or a DATA1 is sent for the next data toggle. This bit has no effect on receiving data packets; sequence checking must be handled in firmware.

- 1: Send a DATA1
- 0: Send a DATA0

Stall Enable (Bit 5)

The Stall Enable bit sends a Stall in response to the next request (unless it is a setup request, which are always ACKed). This is a sticky bit and continues to respond with Stalls until cleared by firmware.

- 1: Send Stall
- 0: Do not send Stall

ISO Enable (Bit 4)

The ISO Enable bit enables and disables an isochronous transaction. This bit is only valid for EPs 1–7 and has no function for EP0.

- 1: Enable isochronous transaction
- 0: Disable isochronous transaction

NAK Interrupt Enable (Bit 3)

The NAK Interrupt Enable bit enables and disables the generation of an Endpoint n interrupt when the device responds to the host with a NAK. The Endpoint n Interrupt Enable bit in the Device n Interrupt Enable register must also be set. When a NAK is sent to the host, the corresponding EP Interrupt Flag in the Device n Status register is set. In addition, the NAK Flag in the Device n Endpoint n Status register is set.

- 1: Enable NAK interrupt
- 0: Disable NAK interrupt

Device n Endpoint n Address Register [R/W]

- Device n Endpoint 0 Address Register [Device 1: 0x0202 Device 2: 0x0282]
- Device n Endpoint 1 Address Register [Device 1: 0x0212 Device 2: 0x0292]
- Device n Endpoint 2 Address Register [Device 1: 0x0222 Device 2: 0x02A2]
- Device n Endpoint 3 Address Register [Device 1: 0x0232 Device 2: 0x02B2]
- Device n Endpoint 4 Address Register [Device 1: 0x0242 Device 2: 0x02C2]
- Device n Endpoint 5 Address Register [Device 1: 0x0252 Device 2: 0x02D2]
- Device n Endpoint 6 Address Register [Device 1: 0x0262 Device 2: 0x02E2]
- Device n Endpoint 7 Address Register [Device 1: 0x0272 Device 2: 0x02F2]

Table 64. Device n Endpoint n Address Register

Bit #	15	14	13	12	11	10	9	8
Field	Address...							
Read/Write	R/W	R/W	R/W	R/W	R/W	R/W	R/W	R/W
Default	X	X	X	X	X	X	X	X

Bit #	7	6	5	4	3	2	1	0
Field	...Address							
Read/Write	R/W	R/W	R/W	R/W	R/W	R/W	R/W	R/W
Default	X	X	X	X	X	X	X	X

Direction Select (Bit 2)

The Direction Select bit needs to be set according to the expected direction of the next data stage in the next transaction. If the data stage direction is different from what is set in this bit, it gets NAKed and either the IN Exception Flag or the OUT Exception Flag is set in the Device n Endpoint n Status register. If a setup packet is received and the Direction Select bit is set incorrectly, the setup is ACKed and the Setup Status Flag is set (refer to the setup bit of the [Device n Endpoint n Status Register \[R/W\]](#) on page 46 for details).

- 1: OUT transfer (host to device)
- 0: IN transfer (device to host)

Enable (Bit 1)

Set the Enable bit to allow transfers to the endpoint. If Enable is set to '0' then all USB traffic to this endpoint is ignored. If Enable is set '1' and Arm Enable (bit 0) is set '0' then NAKs are automatically returned from this endpoint (except setup packets which are always ACKed as long as the Enable bit is set).

- 1: Enable transfers to an endpoint
- 0: Do not allow transfers to an endpoint

Arm Enable (Bit 0)

The Arm Enable bit arms the endpoint to transfer or receive a packet. This bit is cleared to '0' when a transaction is complete.

- 1: Arm endpoint
- 0: Endpoint disarmed

Reserved

Write all reserved bits with '0'.

Register Description

The Device n Endpoint n Address register is used as the base pointer into memory space for the current Endpoint transaction. There are a total of eight endpoints for each of the two ports. All endpoints have the same definition for their Device n Endpoint n Address register.

Address (Bits [15:0])

The Address field sets the base address for the current transaction on a signal endpoint.

Device n Endpoint n Count Register [R/W]

- Device n Endpoint 0 Count Register [Device 1: 0x0204 Device 2: 0x0284]
- Device n Endpoint 1 Count Register [Device 1: 0x0214 Device 2: 0x0294]
- Device n Endpoint 2 Count Register [Device 1: 0x0224 Device 2: 0x02A4]
- Device n Endpoint 3 Count Register [Device 1: 0x0234 Device 2: 0x02B4]
- Device n Endpoint 4 Count Register [Device 1: 0x0244 Device 2: 0x02C4]
- Device n Endpoint 5 Count Register [Device 1: 0x0254 Device 2: 0x02D4]
- Device n Endpoint 6 Count Register [Device 1: 0x0264 Device 2: 0x02E4]
- Device n Endpoint 7 Count Register [Device 1: 0x0274 Device 2: 0x02F4]

Table 65. Device n Endpoint n Count Register

Bit #	15	14	13	12	11	10	9	8
Field	Reserved						Count...	
Read/Write	-	-	-	-	-	-	R/W	R/W
Default	X	X	X	X	X	X	X	X

Bit #	7	6	5	4	3	2	1	0
Field	...Count							
Read/Write	R/W	R/W	R/W	R/W	R/W	R/W	R/W	R/W
Default	X	X	X	X	X	X	X	X

Register Description

The Device n Endpoint n Count register designates the maximum packet size that can be received from the host for OUT transfers for a single endpoint. This register also designates the packet size to be sent to the host in response to the next IN token for a single endpoint. The maximum packet length is 1023 bytes in ISO mode. There are a total of eight endpoints for each of the two ports. All endpoints have the same definition for their Device n Endpoint n Count register.

Count (Bits [9:0])

The Count field sets the current transaction packet length for a single endpoint.

Reserved

Write all reserved bits with '0'.

Device n Endpoint n Status Register [R/W]

- Device n Endpoint 0 Status Register [Device 1: 0x0206 Device 2: 0x0286]
- Device n Endpoint 1 Status Register [Device 1: 0x0216 Device 2: 0x0296]
- Device n Endpoint 2 Status Register [Device 1: 0x0226 Device 2: 0x02A6]
- Device n Endpoint 3 Status Register [Device 1: 0x0236 Device 2: 0x02B6]
- Device n Endpoint 4 Status Register [Device 1: 0x0246 Device 2: 0x02C6]
- Device n Endpoint 5 Status Register [Device 1: 0x0256 Device 2: 0x02D6]
- Device n Endpoint 6 Status Register [Device 1: 0x0266 Device 2: 0x02E6]
- Device n Endpoint 7 Status Register [Device 1: 0x0276 Device 2: 0x02F6]

Table 66. Device n Endpoint n Status Register

Bit #	15	14	13	12	11	10	9	8
Field	Reserved				Overflow Flag	Underflow Flag	OUT Exception Flag	IN Exception Flag
Read/Write	-	-	-	-	R/W	R/W	R/W	R/W
Default	X	X	X	X	X	X	X	X

Bit #	7	6	5	4	3	2	1	0
Field	Stall Flag	NAK Flag	Length Exception Flag	Setup Flag	Sequence Flag	Timeout Flag	Error Flag	ACK Flag
Read/Write	R/W	R/W	R/W	R/W	R/W	R/W	R/W	R/W
Default	X	X	X	X	X	X	X	X

Register Description

The Device n Endpoint n Status register provides packet status information for the last transaction received or transmitted. This register is updated in hardware and does not need to be cleared by firmware. There are a total of eight endpoints for each of the two ports. All endpoints have the same definition for their Device n Endpoint n Status register.

The Device n Endpoint n Status register is a memory based register that must be initialized to 0x0000 before USB Device operations are initiated. After initialization, do not write to this register again.

Overflow Flag (Bit 11)

The Overflow Flag bit indicates that the received data in the last data transaction exceeded the maximum length specified in the Device n Endpoint n Count register. The Overflow Flag must be checked in response to a Length Exception signified by the Length Exception Flag set to '1'.

- 1: Overflow condition occurred
- 0: Overflow condition did not occur

Underflow Flag (Bit 10)

The Underflow Flag bit indicates that the received data in the last data transaction was less than the maximum length specified in the Device n Endpoint n Count register. The Underflow Flag must be checked in response to a Length Exception signified by the Length Exception Flag set to '1'.

- 1: Underflow condition occurred
- 0: Underflow condition did not occur

OUT Exception Flag (Bit 9)

The OUT Exception Flag bit indicates when the device received an OUT packet when armed for an IN.

- 1: Received OUT when armed for IN
- 0: Received IN when armed for IN

IN Exception Flag (Bit 8)

The IN Exception Flag bit indicates when the device received an IN packet when armed for an OUT.

- 1: Received IN when armed for OUT
- 0: Received OUT when armed for OUT

Stall Flag (Bit 7)

The Stall Flag bit indicates that a Stall packet was sent to the host.

- 1: Stall packet was sent to the host
- 0: Stall packet was not sent

NAK Flag (Bit 6)

The NAK Flag bit indicates that a NAK packet was sent to the host.

- 1: NAK packet was sent to the host
- 0: NAK packet was not sent

Length Exception Flag (Bit 5)

The Length Exception Flag bit indicates the received data in the data stage of the last transaction does not equal the maximum Endpoint Count specified in the Device n Endpoint n Count register. A Length Exception can either mean an overflow or

underflow and the Overflow and Underflow flags (bits 11 and 10 respectively) must be checked to determine which event occurred.

- 1: An overflow or underflow condition occurred
- 0: An overflow or underflow condition did not occur

Setup Flag (Bit 4)

The Setup Flag bit indicates that a setup packet was received. In device mode setup packets are stored at memory location 0x0300 for Device 1 and 0x0308 for Device 2. Setup packets are always accepted regardless of the Direction Select and Arm Enable bit settings as long as the Device n EP n Control register Enable bit is set.

- 1: Setup packet was received
- 0: Setup packet was not received

Sequence Flag (Bit 3)

The Sequence Flag bit indicates whether the last data toggle received was a DATA1 or a DATA0. This bit has no effect on receiving data packets; sequence checking must be handled in firmware.

- 1: DATA1 was received
- 0: DATA0 was received

Timeout Flag (Bit 2)

The Timeout Flag bit indicates whether a timeout condition occurred on the last transaction. On the device side, a timeout can occur if the device sends a data packet in response to an IN request but then does not receive a handshake packet in a predetermined time. It can also occur if the device does not receive the data stage of an OUT transfer in time.

- 1: Timeout occurred
- 0: Timeout condition did not occur

Error Flag (Bit 2)

The Error Flag bit is set if a CRC5 and CRC16 error occurs, or if an incorrect packet type is received. Overflow and underflow are not considered errors and do not affect this bit.

- 1: Error occurred
- 0: Error did not occur

ACK Flag (Bit 0)

The ACK Flag bit indicates whether the last transaction was ACKed.

- 1: ACK occurred
- 0: ACK did not occur

Device n Endpoint n Count Result Register [R/W]

- Device n Endpoint 0 Count Result Register [Device 1: 0x0208 Device 2: 0x0288]
- Device n Endpoint 1 Count Result Register [Device 1: 0x0218 Device 2: 0x0298]
- Device n Endpoint 2 Count Result Register [Device 1: 0x0228 Device 2: 0x02A8]
- Device n Endpoint 3 Count Result Register [Device 1: 0x0238 Device 2: 0x02B8]
- Device n Endpoint 4 Count Result Register [Device 1: 0x0248 Device 2: 0x02C8]
- Device n Endpoint 5 Count Result Register [Device 1: 0x0258 Device 2: 0x02D8]
- Device n Endpoint 6 Count Result Register [Device 1: 0x0268 Device 2: 0x02E8]
- Device n Endpoint 7 Count Result Register [Device 1: 0x0278 Device 2: 0x02F8]

Table 67. Device n Endpoint n Count Result Register

Bit #	15	14	13	12	11	10	9	8
Field	Result...							
Read/Write	R/W	R/W	R/W	R/W	R/W	R/W	R/W	R/W
Default	X	X	X	X	X	X	X	X

Bit #	7	6	5	4	3	2	1	0
Field	...Result							
Read/Write	R/W	R/W	R/W	R/W	R/W	R/W	R/W	R/W
Default	X	X	X	X	X	X	X	X

Register Description

The Device n Endpoint n Count Result register contains the size difference in bytes between the Endpoint Count specified in the Device n Endpoint n Count register and the last packet received. If an overflow or underflow condition occurs, that is, the received packet length differs from the value specified in the Device n

Endpoint n Count register, the Length Exception Flag bit in the Device n Endpoint n Status register is set. The value in this register is only valued when the Length Exception Flag bit is set and the Error Flag bit is not set; both bits are in the Device n Endpoint n Status register.

The Device n Endpoint n Count Result register is a memory-based register that must be initialized to 0x0000 before USB Device operations are initiated. After initialization, do not write to this register again.

Result (Bits [15:0])

The Result field contains the differences in bytes between the received packet and the value specified in the Device n Endpoint n Count register. If an overflow condition occurs, Result [15:10] is set to '111111', a 2's complement value indicating the

additional byte count of the received packet. If an underflow condition occurs, Result [15:0] indicates the excess bytes count (number of bytes not used).

Reserved

Write all reserved bits with '0'.

Device n Port Select Register [R/W]

- Device n Port Select Register 0xC084
- Device n Port Select Register 0xC0A4

Table 68. Device n Port Select Register

Bit #	15	14	13	12	11	10	9	8
Field	Reserved	Port Select	Reserved...					
Read/Write	-	R/W	-	-	-	-	-	-
Default	0	0	0	0	0	0	0	0

Bit #	7	6	5	4	3	2	1	0
Field	...Reserved							
Read/Write	-	-	-	-	-	-	-	-
Default	0	0	0	0	0	0	0	0

Register Description

The Device n Port Select register selects either port A or port B for the static device port.

Port Select (Bit 14)

The Port Select bit selects which of the two ports is enabled.

- 1:** Port 1B or Port 2B is enabled
- 0:** Port 1A or Port 2A is enabled

Device n Interrupt Enable Register [R/W]

- Device 1 Interrupt Enable Register 0xC08C
- Device 2 Interrupt Enable Register 0xC0AC

Table 69. Device n Interrupt Enable Register

Bit #	15	14	13	12	11	10	9	8
Field	VBUS Interrupt Enable	ID Interrupt Enable	Reserved		SOF/EOP Timeout Interrupt Enable	Reserved	SOF/EOP Interrupt Enable	Reset Interrupt Enable
Read/Write	R/W	R/W	-	-	R/W	-	R/W	R/W
Default	0	0	0	0	0	0	0	0

Bit #	7	6	5	4	3	2	1	0
Field	EP7 Interrupt Enable	EP6 Interrupt Enable	EP5 Interrupt Enable	EP4 Interrupt Enable	EP3 Interrupt Enable	EP2 Interrupt Enable	EP1 Interrupt Enable	EP0 Interrupt Enable
Read/Write	R/W	R/W	R/W	R/W	R/W	R/W	R/W	R/W
Default	0	0	0	0	0	0	0	0

Register Description ^[12]

The Device n Interrupt Enable register provides control over device related interrupts including eight different endpoint interrupts.

VBUS Interrupt Enable (Bit 15)

The VBUS Interrupt Enable bit enables or disables the OTG VBUS interrupt. When enabled, this interrupt triggers on both the rising and falling edge of VBUS at the 4.4V status (only supported in Port 1A). This bit is only available for Device 1 and is a reserved bit in Device 2.

- 1: Enable VBUS interrupt
- 0: Disable VBUS interrupt

ID Interrupt Enable (Bit 14)

The ID Interrupt Enable bit enables or disables the OTG ID interrupt. When enabled, this interrupt triggers on both the rising and falling edge of the OTG ID pin (only supported in Port 1A). This bit is only available for Device 1 and is a reserved bit in Device 2.

- 1: Enable ID interrupt
- 0: Disable ID interrupt

SOF/EOP Timeout Interrupt Enable (Bit 11)

The SOF/EOP Timeout Interrupt Enable bit enables or disables the SOF/EOP Timeout Interrupt. When enabled this interrupt triggers when the USB host fails to send a SOF or EOP packet within the time period specified in the Device n SOF/EOP Count register. In addition, the Device n Frame register counts the number of times the SOF/EOP Timeout Interrupt triggers between receiving SOF/EOPs.

- 1: SOF/EOP timeout occurred
- 0: SOF/EOP timeout did not occur

SOF/EOP Interrupt Enable (Bit 9)

The SOF/EOP Interrupt Enable bit enables or disables the SOF/EOP received interrupt.

- 1: Enable SOF/EOP received interrupt
- 0: Disable SOF/EOP received interrupt

Reset Interrupt Enable (Bit 8)

The Reset Interrupt Enable bit enables or disables the USB Reset Detected interrupt

- 1: Enable USB Reset Detected interrupt
- 0: Disable USB Reset Detected interrupt

EP7 Interrupt Enable (Bit 7)

The EP7 Interrupt Enable bit enables or disables endpoint seven (EP7) Transaction Done interrupt. An EPx Transaction Done interrupt triggers when any of the following responses or events occur in a transaction for the device's supplied Endpoint: send/receive ACK, send STALL, Timeout occurs, IN Exception Error, or OUT Exception Error. In addition, the NAK Interrupt Enable bit in the Device n Endpoint Control register can also be set so that NAK responses trigger this interrupt.

- 1: Enable EP7 Transaction Done interrupt
- 0: Disable EP7 Transaction Done interrupt

EP6 Interrupt Enable (Bit 6)

The EP6 Interrupt Enable bit enables or disables endpoint six (EP6) Transaction Done interrupt. An EPx Transaction Done interrupt triggers when any of the following responses or events occur in a transaction for the device's supplied Endpoint: send/receive ACK, send STALL, Timeout occurs, IN Exception Error, or OUT Exception Error. In addition, the NAK Interrupt Enable bit in the Device n Endpoint Control register can also be set so that NAK responses trigger this interrupt.

- 1: Enable EP6 Transaction Done interrupt
- 0: Disable EP6 Transaction Done interrupt

Note

12. **Errata:** USB peripheral designs may miss endpoint interrupts when receiving Endpoint 0 (EP0) Control transfer requests mixed with other endpoint transfer type transactions. When an SIE is configured as a peripheral, data toggle corruption as specified in the USB 2.0 specification, section 8.6.4, does not work as specified. Please refer to [Errata on page 107](#) for details and workaround.

EP5 Interrupt Enable (Bit 5)

The EP5 Interrupt Enable bit enables or disables endpoint five (EP5) Transaction Done interrupt. An EPx Transaction Done interrupt triggers when any of the following responses or events occur in a transaction for the device's supplied Endpoint: send/receive ACK, send STALL, Timeout occurs, IN Exception Error, or OUT Exception Error. In addition, the NAK Interrupt Enable bit in the Device n Endpoint Control register can also be set so that NAK responses trigger this interrupt.

- 1: Enable EP5 Transaction Done interrupt
- 0: Disable EP5 Transaction Done interrupt

EP4 Interrupt Enable (Bit 4)

The EP4 Interrupt Enable bit enables or disables endpoint four (EP4) Transaction Done interrupt. An EPx Transaction Done interrupt triggers when any of the following responses or events occur in a transaction for the device's supplied Endpoint: send/receive ACK, send STALL, Timeout occurs, IN Exception Error, or OUT Exception Error. In addition, the NAK Interrupt Enable bit in the Device n Endpoint Control register can also be set so that NAK responses trigger this interrupt.

- 1: Enable EP4 Transaction Done interrupt
- 0: Disable EP4 Transaction Done interrupt

EP3 Interrupt Enable (Bit 3)

The EP3 Interrupt Enable bit enables or disables endpoint three (EP3) Transaction Done interrupt. An EPx Transaction Done interrupt triggers when any of the following responses or events occur in a transaction for the device's supplied Endpoint: send/receive ACK, send STALL, Timeout occurs, IN Exception Error, or OUT Exception Error. In addition, the NAK Interrupt Enable bit in the Device n Endpoint Control register can also be set so that NAK responses trigger this interrupt.

- 1: Enable EP3 Transaction Done interrupt
- 0: Disable EP3 Transaction Done interrupt

EP2 Interrupt Enable (Bit 2)

The EP2 Interrupt Enable bit enables or disables endpoint two (EP2) Transaction Done interrupt. An EPx Transaction Done interrupt triggers when any of the following responses or events occur in a transaction for the device's supplied Endpoint: send/receive ACK, send STALL, Timeout occurs, IN Exception Error, or OUT Exception Error. In addition, the NAK Interrupt Enable bit in the Device n Endpoint Control register can also be set so that NAK responses trigger this interrupt.

- 1: Enable EP2 Transaction Done interrupt
- 0: Disable EP2 Transaction Done interrupt

EP1 Interrupt Enable (Bit 1)

The EP1 Interrupt Enable bit enables or disables endpoint one (EP1) Transaction Done interrupt. An EPx Transaction Done interrupt triggers when any of the following responses or events occur in a transaction for the device's supplied Endpoint: send/receive ACK, send STALL, Timeout occurs, IN Exception Error, or OUT Exception Error. In addition, the NAK Interrupt Enable bit in the Device n Endpoint Control register can also be set so that NAK responses trigger this interrupt.

- 1: Enable EP1 Transaction Done interrupt
- 0: Disable EP1 Transaction Done interrupt

EP0 Interrupt Enable (Bit 0)

The EP0 Interrupt Enable bit enables or disables endpoint zero (EP0) Transaction Done interrupt. An EPx Transaction Done interrupt triggers when any of the following responses or events occur in a transaction for the device's supplied Endpoint: send/receive ACK, send STALL, Timeout occurs, IN Exception Error, or OUT Exception Error. In addition, the NAK Interrupt Enable bit in the Device n Endpoint Control register can also be set so that NAK responses trigger this interrupt.

- 1: Enable EP0 Transaction Done interrupt
- 0: Disable EP0 Transaction Done interrupt

Reserved

Write all reserved bits with '0'.

Device n Address Register [W]

- Device 1 Address Register 0xC08E
- Device 2 Address Register 0xC0AE

Table 70. Device n Address Register

Bit #	15	14	13	12	11	10	9	8
Field	Reserved...							
Read/Write	-	-	-	-	-	-	-	-
Default	0	0	0	0	0	0	0	0

Bit #	7	6	5	4	3	2	1	0
Field	...Reserved	Address						
Read/Write	-	W	W	W	W	W	W	W
Default	0	0	0	0	0	0	0	0

Register Description

The Device n Address register holds the device address assigned by the host. This register initializes to the default

address 0 at reset but must be updated by firmware when the host assigns a new address. Only USB data sent to the address contained in this register gets a respond—all others are ignored.

Address (Bits [6:0])

The Address field contains the USB address of the device assigned by the host.

Reserved

Write all reserved bits with '0'.

Device n Status Register [R/W]

■ Device 1 Status Register 0xC090

■ Device 2 Status Register 0xC0B0

Table 71. Device n Status Register

Bit #	15	14	13	12	11	10	9	8
Field	VBUS Interrupt Flag	ID Interrupt Flag	Reserved				SOF/EOP Interrupt Flag	Reset Interrupt Flag
Read/Write	R/W	R/W	-	-	-	-	R/W	R/W
Default	X	X	X	X	X	X	X	X

Bit #	7	6	5	4	3	2	1	0
Field	EP7 Interrupt Flag	EP6 Interrupt Flag	EP5 Interrupt Flag	EP4 Interrupt Flag	EP3 Interrupt Flag	EP2 Interrupt Flag	EP1 Interrupt Flag	EP0 Interrupt Flag
Read/Write	R/W	R/W	R/W	R/W	R/W	R/W	R/W	R/W
Default	X	X	X	X	X	X	X	X

Register Description

The Device n Status register provides status information for device operation. Pending interrupts can be cleared by writing a '1' to the corresponding bit. This register can be accessed by the HPI interface.

VBUS Interrupt Flag (Bit 15)

The VBUS Interrupt Flag bit indicates the status of the OTG VBUS interrupt (only for Port 1A). When enabled this interrupt triggers on both the rising and falling edge of VBUS at 4.4V. This bit is only available for Device 1 and is a reserved bit in Device 2.

1: Interrupt triggered

0: Interrupt did not trigger

ID Interrupt Flag (Bit 14)

The ID Interrupt Flag bit indicates the status of the OTG ID interrupt (only for Port 1A). When enabled this interrupt triggers on both the rising and falling edge of the OTG ID pin. This bit is only available for Device 1 and is a reserved bit in Device 2.

1: Interrupt triggered

0: Interrupt did not trigger

SOF/EOP Interrupt Flag (Bit 9)

The SOF/EOP Interrupt Flag bit indicates if the SOF/EOP received interrupt triggered.

1: Interrupt triggered

0: Interrupt did not trigger

Reset Interrupt Flag (Bit 8)

The Reset Interrupt Flag bit indicates if the USB Reset Detected interrupt triggered.

1: Interrupt triggered

0: Interrupt did not trigger

EP7 Interrupt Flag (Bit 7)

The EP7 Interrupt Flag bit indicates if the endpoint seven (EP7) Transaction Done interrupt triggered. An EPx Transaction Done interrupt triggers when any of the following responses or events occur in a transaction for the device's supplied EP: send/receive ACK, send STALL, Timeout occurs, IN Exception Error, or OUT Exception Error. In addition, if the NAK Interrupt Enable bit in the Device n Endpoint Control register is set, this interrupt also triggers when the device NAKs host requests.

1: Interrupt triggered

0: Interrupt did not trigger

EP6 Interrupt Flag (Bit 6)

The EP6 Interrupt Flag bit indicates if the endpoint six (EP6) Transaction Done interrupt triggered. An EPx Transaction Done interrupt triggers when any of the following responses or events occur in a transaction for the device's supplied EP: send/receive ACK, send STALL, Timeout occurs, IN Exception Error, or OUT Exception Error. In addition, if the NAK Interrupt Enable bit in the Device n Endpoint Control register is set, this interrupt also triggers when the device NAKs host requests.

1: Interrupt triggered

0: Interrupt did not trigger

EP5 Interrupt Flag (Bit 5)

The EP5 Interrupt Flag bit indicates if the endpoint five (EP5) Transaction Done interrupt triggered. An EPx Transaction Done interrupt triggers when any of the following responses or events occur in a transaction for the device's supplied EP: send/receive ACK, send STALL, Timeout occurs, IN Exception Error, or OUT Exception Error. In addition, if the NAK Interrupt Enable bit in the Device n Endpoint Control register is set, this interrupt also triggers when the device NAKs host requests.

1: Interrupt triggered

0: Interrupt did not trigger

EP4 Interrupt Flag (Bit 4)

The EP4 Interrupt Flag bit indicates if the endpoint four (EP4) Transaction Done interrupt triggered. An EPx Transaction Done interrupt triggers when any of the following responses or events occur in a transaction for the device's supplied EP: send/receive ACK, send STALL, Timeout occurs, IN Exception Error, or OUT Exception Error. In addition, if the NAK Interrupt Enable bit in the Device n Endpoint Control register is set, this interrupt also triggers when the device NAKs host requests.

1: Interrupt triggered

0: Interrupt did not trigger

EP3 Interrupt Flag (Bit 3)

The EP3 Interrupt Flag bit indicates if the endpoint three (EP3) Transaction Done interrupt triggered. An EPx Transaction Done interrupt triggers when any of the following responses or events occur in a transaction for the device's supplied EP: send/receive ACK, send STALL, Timeout occurs, IN Exception Error, or OUT Exception Error. In addition, if the NAK Interrupt Enable bit in the

Device n Endpoint Control register is set, this interrupt also triggers when the device NAKs host requests.

1: Interrupt triggered

0: Interrupt did not trigger

EP2 Interrupt Flag (Bit 2)

The EP2 Interrupt Flag bit indicates if the endpoint two (EP2) Transaction Done interrupt triggered. An EPx Transaction Done interrupt triggers when any of the following responses or events occur in a transaction for the device's supplied EP: send/receive ACK, send STALL, Timeout occurs, IN Exception Error, or OUT Exception Error. In addition, if the NAK Interrupt Enable bit in the Device n Endpoint Control register is set, this interrupt also triggers when the device NAKs host requests.

1: Interrupt triggered

0: Interrupt did not trigger

EP1 Interrupt Flag (Bit 1)

The EP1 Interrupt Flag bit indicates if the endpoint one (EP1) Transaction Done interrupt triggered. An EPx Transaction Done interrupt triggers when any of the following responses or events occur in a transaction for the device's supplied EP: send/receive ACK, send STALL, Timeout occurs, IN Exception Error, or OUT Exception Error. In addition, if the NAK Interrupt Enable bit in the Device n Endpoint Control register is set, this interrupt also triggers when the device NAKs host requests.

1: Interrupt triggered

0: Interrupt did not trigger

EP0 Interrupt Flag (Bit 0)

The EP0 Interrupt Flag bit indicates if the endpoint zero (EP0) Transaction Done interrupt triggered. An EPx Transaction Done interrupt triggers when any of the following responses or events occur in a transaction for the device's supplied EP: send/receive ACK, send STALL, Timeout occurs, IN Exception Error, or OUT Exception Error. In addition, if the NAK Interrupt Enable bit in the Device n Endpoint Control register is set, this interrupt also triggers when the device NAKs host requests.

1: Interrupt triggered

0: Interrupt did not trigger

Reserved

Write all reserved bits with '0'.

Device n Frame Number Register [R]

- Device 1 Frame Number Register 0xC092
- Device 2 Frame Number Register 0xC0B2

Table 72. Device n Frame Number Register

Bit #	15	14	13	12	11	10	9	8
Field	SOF/EOP Timeout Flag	SOF/EOP Timeout Interrupt Counter			Reserved	Frame...		
Read/Write	R	R	R	R	-	R	R	R
Default	0	0	0	0	0	0	0	0

Bit #	7	6	5	4	3	2	1	0
Field	...Frame							
Read/Write	R	R	R	R	R	R	R	R
Default	0	0	0	0	0	0	0	0

Register Description

The Device n Frame Number register is a read only register that contains the Frame number of the last SOF packet received. This register also contains a count of SOF/EOP Timeout occurrences.

SOF/EOP Timeout Flag (Bit 15)

The SOF/EOP Timeout Flag bit indicates when an SOF/EOP Timeout Interrupt occurs.

- 1:** An SOF/EOP Timeout interrupt occurred
- 0:** An SOF/EOP Timeout interrupt did not occur

SOF/EOP Timeout Interrupt Counter (Bits [14:12])

The SOF/EOP Timeout Interrupt Counter field increments by 1 from 0 to 7 for each SOF/EOP Timeout Interrupt. This field resets to 0 when a SOF/EOP is received. This field is only updated when the SOF/EOP Timeout Interrupt Enable bit in the Device n Interrupt Enable register is set.

Frame (Bits [10:0])

The Frame field contains the frame number from the last received SOF packet in full-speed mode. This field no function for low-speed mode. If a SOF Timeout occurs, this field contains the last received Frame number.

Device n SOF/EOP Count Register [W]

- Device 1 SOF/EOP Count Register 0xC094
- Device 2 SOF/EOP Count Register 0xC0B4

Table 73. Device n SOF/EOP Count Register

Bit #	15	14	13	12	11	10	9	8
Field	Reserved		Count...					
Read/Write	-	-	R	R	R	R	R	R
Default	0	0	1	0	1	1	1	0

Bit #	7	6	5	4	3	2	1	0
Field	...Count							
Read/Write	R	R	R	R	R	R	R	R
Default	1	1	1	0	0	0	0	0

Register Description

The Device n SOF/EOP Count register is written with the time expected between receiving a SOF/EOP. If the SOF/EOP counter expires before an SOF/EOP is received, an SOF/EOP Timeout Interrupt can be generated. The SOF/EOP Timeout Interrupt Enable and SOF/EOP Timeout Interrupt Flag are located in the Device n Interrupt Enable and Status registers respectively.

Set the SOF/EOP count slightly greater than the expected SOF/EOP interval. The SOF/EOP counter decrements at a 12 MHz rate. Therefore, in the case of an expected 1 ms SOF/EOP interval, the SOF/EOP count is set slightly greater than 0x2EE0.

Count (Bits [13:0])

The Count field contains the current value of the SOF/EOP down counter. At power up and reset, this value is set to 0x2EE0 and for expected 1 ms SOF/EOP intervals, this SOF/EOP count is increased slightly.

Reserved

Write all reserved bits with '0'.

OTG Control Registers ^[13]

There is one register dedicated for On-The-Go operation. This register is covered in this section and summarized in [Table 74](#).

Table 74. OTG Register

Register Name	Address	R/W
OTG Control Register	C098H	R/W

Note

- 13. Errata:** The VBUS interrupt in the OTG Control Register [0xC098] triggers multiple times whenever VBUS is turned on. It should only trigger once when VBUS rises above 4.4V and once when VBUS falls from above 4.4V to 0V. Please refer to [Errata on page 107](#) for details and workaround.

OTG Control Register [0xC098] [R/W]

Table 75. OTG Control Register

Bit #	15	14	13	12	11	10	9	8
Field	Reserved		VBUS Pull-up Enable	Receive Disable	Charge Pump Enable	VBUS Discharge Enable	D+ Pull-up Enable	D- Pull-up Enable
Read/Write	-	-	R/W	R/W	R/W	R/W	R/W	R/W
Default	0	0	0	0	0	0	0	0

Bit #	7	6	5	4	3	2	1	0
Field	D+ Pull-down Enable	D- Pull-down Enable	Reserved			OTG Data Status	ID Status	VBUS Valid Flag
Read/Write	R/W	R/W	-	-	-	R	R	R
Default	0	0	0	0	0	X	X	X

Register Description

The OTG Control register allows control and monitoring over the OTG port on Port1A. Note that the D± pull up and pull down bits override the setting in the USB 0 Control register for this port.

VBUS Pull-up Enable (Bit 13)

The VBUS Pull-up Enable bit enables or disables a 500 ohm pull up resistor onto OTG VBus.

1: 500 ohm pull up resistor enabled

0: 500 ohm pull up resistor disabled

Receive Disable (Bit 12)

The Receive Disable bit enables or powers down (disables) the OTG receiver section.

1: OTG receiver powered down and disabled

0: OTG receiver enabled

Charge Pump Enable (Bit 11)

The Charge Pump Enable bit enables or disables the OTG VBus charge pump.

1: OTG VBus charge pump enabled

0: OTG VBus charge pump disabled

VBUS Discharge Enable (Bit 10)

The VBUS Discharge Enable bit enables or disables a 2K ohm discharge pull down resistor onto OTG VBus.

1: 2K ohm pull down resistor enabled

0: 2K ohm pull down resistor disabled

D+ Pull-up Enable (Bit 9)

The D+ Pull-up Enable bit enables or disables a pull up resistor on the OTG D+ data line.

1: OTG D+ dataline pull up resistor enabled

0: OTG D+ dataline pull up resistor disabled

D- Pull-up Enable (Bit 8)

The D- Pull-up Enable bit enables or disables a pull up resistor on the OTG D- data line.

1: OTG D- dataline pull up resistor enabled

0: OTG D- dataline pull up resistor disabled

D+ Pull-down Enable (Bit 7)

The D+ Pull-down Enable bit enables or disables a pull down resistor on the OTG D+ data line.

1: OTG D+ dataline pull down resistor enabled

0: OTG D+ dataline pull down resistor disabled

D- Pull-down Enable (Bit 6)

The D- Pull-down Enable bit enables or disables a pull down resistor on the OTG D- data line.

1: OTG D- dataline pull down resistor enabled

0: OTG D- dataline pull down resistor disabled

OTG Data Status (Bit 2)

The OTG Data Status bit is a read only bit and indicates the TTL logic state of the OTG VBus pin.

1: OTG VBus is greater then 2.4V

0: OTG VBus is less then 0.8V

ID Status (Bit 1)

The ID Status bit is a read only bit that indicates the state of the OTG ID pin on Port A.

1: OTG ID Pin is not connected directly to ground (>10K ohm)

0: OTG ID Pin is connected directly ground (< 10 ohm)

VBUS Valid Flag (Bit 0)

The VBUS Valid Flag bit indicates whether OTG VBus is greater then 4.4V. After turning on VBUS, firmware must wait at least 10 μs before this reading this bit.

1: OTG VBus is greater then 4.4V

0: OTG VBus is less then 4.4V

Reserved

Write all reserved bits with '0'.

GPIO Registers

There are seven registers dedicated for GPIO operations. These seven registers are covered in this section and summarized in [Table 76](#).

Table 76. GPIO Registers

Register Name	Address	R/W
GPIO Control Register	0xC006	R/W
GPIO0 Output Data Register	0xC01E	R/W
GPIO0 Input Data Register	0xC020	R

Table 76. GPIO Registers

Register Name	Address	R/W
GPIO0 Direction Register	0xC022	R/W
GPIO1 Output Data Register	0xC024	R/W
GPIO1 Input Data Register	0xC026	R
GPIO1 Direction Register	0xC028	R/W

GPIO Control Register [0xC006] [R/W]

Table 77. GPIO Control Register

Bit #	15	14	13	12	11	10	9	8
Field	Write Protect Enable	UD	Reserved		SAS Enable	Mode Select		
Read/Write	R/W	R/W	-	-	R/W	R/W	R/W	R/W
Default	0	0	0	0	0	0	0	0

Bit #	7	6	5	4	3	2	1	0
Field	HSS Enable	HSS XD Enable	SPI Enable	SPI XD Enable	Interrupt 1 Polarity Select	Interrupt 1 Enable	Interrupt 0 Polarity Select	Interrupt 0 Enable
Read/Write	R/W	R/W	R/W	R/W	R/W	R/W	R/W	R/W
Default	0	0	0	0	0	0	0	0

Register Description

The GPIO Control register configures the GPIO pins for various interface options. It also controls the polarity of the GPIO interrupt on IRQ1 (GPIO25) and IRQ0 (GPIO24).

Write Protect Enable (Bit 15)

The Write Protect Enable bit enables or disables the GPIO write protect. When Write Protect is enabled, the GPIO Mode Select [15:8] field is read only until a chip reset.

1: Enable Write Protect

0: Disable Write Protect

UD (Bit 14)

The UD bit routes the Host/Device 1A Port's transmitter enable status to GPIO[30]. This is for use with an external ESD protection circuit when needed.

1: Route the signal to GPIO[30]

0: Do not route the signal to GPIO[30]

SAS Enable (Bit 11)

The SAS Enable bit, when in SPI mode, reroutes the SPI port SPI_nSSI pin to GPIO[15] rather than GPIO[9] or XD[9] (per SG/SX).

1: Reroute SPI_nss to GPIO[30]

0: Leave SPI_nss on GPIO[9]

Mode Select (Bits [10:8])

The Mode Select field selects how GPIO[15:0] and GPIO[24:19] are used as defined in [Table 78](#).

Table 78. Mode Select Definition

Mode Select [10:8]	GPIO Configuration
111	Reserved
110	SCAN — (HW) Scan diagnostic. For production test only. Not for normal operation
101	HPI — Host Port Interface
100	IDE — Integrated Drive Electronics or
011	Reserved
010	Reserved
001	Reserved
000	GPIO — General Purpose Input Output

HSS Enable (Bit 7)

The HSS Enable bit routes HSS to GPIO[26, 18:16]. If the HSS XD Enable bit is set, it overrides this bit and HSS is routed to XD[15:12].

1: HSS is routed to GPIO

0: HSS is not routed to GPIOs. GPIO[26, 18:16] are free for other

HSS XD Enable (Bit 6)

The HSS XD Enable bit routes HSS to XD[15:12] (external memory data bus). This bit overrides the HSS Enable bit.

- 1: HSS is routed to XD[15:12]
- 0: HSS is not routed to XD[15:12]

SPI Enable (Bit 5)

The SPI Enable bit routes SPI to GPIO[11:8]. If the SAS Enable bit is set, it overrides the SPI Enable and routes SPI_nSSI to GPIO15. If the SPI XD Enable bit is set, it overrides both bits and the SPI is routed to XD[11:8] (external memory data bus).

- 1: SPI is routed to GPIO[11:8]
- 0: SPI is not routed to GPIO[11:8]. GPIO[11:8] are free for other purposes

SPI XD Enable (Bit 4)

The SPI XD Enable bit routes SPI to XD[11:8] (external memory data bus). This bit overrides the SPI Enable bit.

- 1: SPI is routed to XD[11:8]
- 0: SPI is not routed to XD[11:8]

Interrupt 1 Polarity Select (Bit 3)

The Interrupt 1 Polarity Select bit selects the polarity for IRQ1.

- 1: Sets IRQ1 to rising edge
- 0: Sets IRQ1 to falling edge

Interrupt 1 Enable (Bit 2)

The Interrupt 1 Enable bit enables or disables IRQ1. The GPIO bit on the interrupt Enable register must also be set in order for this for this interrupt to be enabled.

- 1: Enable IRQ1
- 0: Disable IRQ1

Interrupt 0 Polarity Select (Bit 1)

The Interrupt 0 Polarity Select bit selects the polarity for IRQ0.

- 1: Sets IRQ0 to rising edge
- 0: Sets IRQ0 to falling edge

Interrupt 0 Enable (Bit 0)

The Interrupt 0 Enable bit enables or disables IRQ0. The GPIO bit on the interrupt Enable register must also be set in order for this for this interrupt to be enabled.

- 1: Enable IRQ0
- 0: Disable IRQ0

Reserved

Write all reserved bits with '0'.

GPIO n Output Data Register [R/W]

- GPIO 0 Output Data Register 0xC01E
- GPIO 1 Output Data Register 0xC024

Table 79. GPIO n Output Data Register

Bit #	31/15	30/14	29/13	28/12	27/11	26/10	25/9	24/8
Field	Data...							
Read/Write	R/W	R/W	R/W	R/W	R/W	R/W	R/W	R/W
Default	0	0	0	0	0	0	0	0
Bit #	23/7	22/6	21/5	20/4	19/3	18/2	17/1	16/0
Field	...Data							
Read/Write	R/W	R/W	R/W	R/W	R/W	R/W	R/W	R/W
Default	0	0	0	0	0	0	0	0

Register Description

The GPIO n Output Data register controls the output data of the GPIO pins. The GPIO 0 Output Data register controls GPIO15 to GPIO0 while the GPIO 1 Output Data register controls GPIO31 to GPIO16. When read, this register reads back the last data written, not the data on pins configured as inputs (see Input Data Register).

Data (Bits [15:0])

The Data field[15:0] writes to the corresponding GPIO 15–0 or GPIO31–16 pins as output data.

GPIO n Input Data Register [R]

- GPIO 0 Input Data Register 0xC020
- GPIO 1 Input Data Register 0xC026

Table 80. GPIO n Input Data Register

Bit #	31/15	30/14	29/13	28/12	27/11	26/10	25/9	24/8
Field	Data...							
Read/Write	R	R	R	R	R	R	R	R
Default	0	0	0	0	0	0	0	0

Bit #	23/7	22/6	21//5	20/4	19/3	18/2	17/1	16/0
Field	...Data							
Read/Write	R	R	R	R	R	R	R	R
Default	0	0	0	0	0	0	0	0

Register Description

The GPIO n Input Data register reads the input data of the GPIO pins. The GPIO 0 Input Data register reads from GPIO15 to GPIO0 while the GPIO 1 Input Data register reads from GPIO31 to GPIO16.

Data (Bits [15:0])

The Data field[15:0] contains the voltage values on the corresponding GPIO15–0 or GPIO31–16 input pins.

GPIO n Direction Register [R/W]

- GPIO 0 Direction Register 0xC022
- GPIO 1 Direction Register 0xC028

Table 81. GPIO n Direction Register

Bit #	31/15	30/14	29/13	28/12	27/11	26/10	25/9	24/8
Field	Direction Select...							
Read/Write	R/W	R/W	R/W	R/W	R/W	R/W	R/W	R/W
Default	0	0	0	0	0	0	0	0

Bit #	23/7	22/6	21/5	20/4	19/3	18/2	17/1	16/0
Field	...Direction Select							
Read/Write	R/W	R/W	R/W	R/W	R/W	R/W	R/W	R/W
Default	0	0	0	0	0	0	0	0

Register Description

The GPIO n Direction register controls the direction of the GPIO data pins (input/output). The GPIO 0 Direction register controls GPIO15 to GPIO0 while the GPIO 1 Direction register controls GPIO31 to GPIO16.

Direction Select (Bits [15:0])

The Direction Select field[15:0] configures the corresponding GPIO15–0 or GPIO31–16 pins as either input or output. When any bit of this register is set to ‘1’, the corresponding GPIO data pin becomes an output. When any bit of this register is set to ‘0’, the corresponding GPIO data pin becomes an input.

IDE Registers

In addition to the standard IDE PIO Port registers, there are four registers dedicated to IDE operation. These registers are covered in this section and summarized in [Table 82](#).

Table 82. IDE Registers ^[14]

Register Name	Address	R/W
IDE Mode Register	0xC048	R/W
IDE Start Address Register	0xC04A	R/W
IDE Stop Address Register	0xC04C	R/W
IDE Control Register	0xC04E	R/W
IDE PIO Port Registers	0xC050-0xC06F	R/W

IDE Mode Register [0xC048] [R/ W]

Table 83. IDE Mode Register

Bit #	15	14	13	12	11	10	9	8
Field	Reserved...							
Read/Write	-	-	-	-	-	-	-	-
Default	0	0	0	0	0	0	0	0

Bit #	7	6	5	4	3	2	1	0
Field	...Reserved				Mode Select			
Read/Write	-	-	-	-	R/W	R/W	R/W	R/W
Default	0	0	0	0	0	0	0	0

Register Description

The IDE Mode register allows the selection of IDE PIO Modes 0, 1, 2, 3, or 4. The default setting is zero which means IDE PIO Mode 0.

Mode Select (Bits [2:0])

The Mode Select field sets PIO Mode 0 to 4 in IDE mode. Refer to [Table 84 on page 60](#) for a definition of this field.

Note

14. Errata: The part does not service USB ISRs when the GPIO24 pin (also labeled as HPI_INT and IORDY) is low and any IDE register is read. Please refer to [Errata on page 107](#) for details and workaround.

Table 84. Mode Select Definition

Mode Select [2:0]	Mode
000	IDE PIO Mode 0
001	IDE PIO Mode 1
010	IDE PIO Mode 2
011	IDE PIO Mode 3
100	IDE PIO Mode 4
101	Reserved
110	Reserved
111	Disable IDE port operations

Reserved

Write all reserved bits with '0'.

IDE Start Address Register [0xC04A] [R/W]

Table 85. IDE Start Address Register

Bit #	15	14	13	12	11	10	9	8
Field	Address...							
Read/Write	R/W	R/W	R/W	R/W	R/W	R/W	R/W	R/W
Default	0	0	0	0	0	0	0	0

Bit #	7	6	5	4	3	2	1	0
Field	...Address							
Read/Write	R/W	R/W	R/W	R/W	R/W	R/W	R/W	R/W
Default	0	0	0	0	0	0	0	0

Register Description

The IDE Start Address register holds the start address for an IDE block transfer. This register is byte addressed and IDE block transfers are 16-bit words, therefore the LSB of the start address is ignored. Block transfers begin at IDE Start Address and end with the final word at IDE Stop Address. When IDE Start Address equals IDE Stop Address, the block transfer moves one word of data.

The hardware keeps an internal memory address counter. The two MSBs of the addresses are not modified by the address counter. Therefore, the IDE Start Address and IDE Stop Address must reside within the same 16K byte block.

Address (Bits [15:0])

The Address field sets the start address for an IDE block transfer.

IDE Stop Address Register [0xC04C] [R/W]
Table 86. IDE Stop Address Register

Bit #	15	14	13	12	11	10	9	8
Field	Address...							
Read/Write	R/W	R/W	R/W	R/W	R/W	R/W	R/W	R/W
Default	0	0	0	0	0	0	0	0

Bit #	7	6	5	4	3	2	1	0
Field	...Address							
Read/Write	R/W	R/W	R/W	R/W	R/W	R/W	R/W	R/W
Default	0	0	0	0	0	0	0	0

Register Description

The IDE Stop Address register holds the stop address for an IDE block transfer. This register is byte addressed and IDE block transfers are 16-bit words, therefore the LSB of the stop address is ignored. Block transfers begin at IDE Start Address and end with the final word at IDE Stop Address. When IDE Start Address equals IDE Stop Address, the block transfer moves one word of data.

The hardware keeps an internal memory address counter. The two MSBs of the addresses are not modified by the address counter. Therefore the IDE Start Address and IDE Stop Address must reside within the same 16K byte block.

Address (Bits [15:0])

The Address field sets the stop address for an IDE block transfer.

IDE Control Register [0xC04E] [R/W]
Table 87. IDE Control Register

Bit #	15	14	13	12	11	10	9	8
Field	Reserved...							
Read/Write	-	-	-	-	-	-	-	-
Default	0	0	0	0	0	0	0	0

Bit #	7	6	5	4	3	2	1	0
Field	...Reserved				Direction Select	IDE Interrupt Enable	Done Flag	IDE Enable
Read/Write	-	-	-	-	R/W	R/W	R/W	R/W
Default	0	0	0	0	0	0	0	0

Register Description

The IDE Control register controls block transfers in IDE mode.

Direction Select (Bit 3)

The Direction Select bit sets the block mode transfer direction.

1: Data is written to the external device

0: Data is read from the external device

IDE Interrupt Enable (Bit 2)

The IDE Interrupt Enable bit enables or disables the block transfer done interrupt. When enabled, the Done Flag is sent to the CPU as `cpuide_intr` interrupt. When disabled, the `cpuide_intr` is set LOW.

1: Enable block transfer done interrupt

0: Disable block transfer done interrupt

Done Flag (Bit 1)

The Done Flag bit is automatically set to '1' by hardware when a block transfer is complete. The CPU clears this bit by writing a '0' to it. When IDE Interrupt Enable is set this bit generates the signal for the `cpuide_intr` interrupt.

1: Block transfer is complete

0: Clears IDE Done Flag

IDE Enable (Bit 0)

The IDE Enable bit starts a block transfer. It is reset to '0' when the block transfer is complete

1: Start block transfer

0: Block transfer complete

Reserved

Write all reserved bits with '0'.

IDE PIO Port Registers [0xC050 - 0xC06F] [R/W]

All IDE PIO Port registers [0xC050 - 0xC06F] in [Table 88](#) are defined in detail in the Information Technology-ATA Attachment -4 with Packet Interface Extension (ATA/ATAPI-4) Specification, T13/1153D Rev 18. The table Address column denotes the CY7C67300 register address for the corresponding ATA/ATAPI register. The IDE_nCS[1:0] field defines the ATA interface CS addressing bits and the IDE_A[2:0] field define the ATA interface address bits. The combination of IDE_nCS and IDE_A are the ATA interface register address.

Table 88. IDE PIO Port Registers

Address	ATA/ATAPI Register	IDE_nCS[1:0]	IDE_A[2:0]
0xC050	DATA Register	'10'	'000'
0xC052	Read: Error Register Write: Feature Register	'10'	'001'
0xC054	Sector Count Register	'10'	'010'
0xC056	Sector Number Register	'10'	'011'
0xC058	Cylinder Low Register	'10'	'100'
0xC05A	Cylinder High Register	'10'	'101'
0xC05C	Device/Head Register	'10'	'110'
0xC05E	Read: Status Register Write: Command Register	'10'	'111'
0xC060	Not Defined	'01'	'000'
0xC062	Not Defined	'01'	'001'
0xC064	Not Defined	'01'	'010'
0xC066	Not Defined	'01'	'011'
0xC068	Not Defined	'01'	'100'
0xC06A	Not Defined	'01'	'101'
0xC06C	Read: Alternate Status Register Write: Device Control Register	'01'	'110'
0xC06E	Not Defined	'01'	'111'

HSS Registers

There are eight registers dedicated to HSS operation. Each of these registers are covered in this section and summarized in [Table 89](#).

Table 89. HSS Registers

Register Name	Address	R/W
HSS Control Register	0xC070	R/W
HSS Baud Rate Register	0xC072	R/W
HSS Transmit Gap Register	0xC074	R/W
HSS Data Register	0xC076	R/W
HSS Receive Address Register	0xC078	R/W
HSS Receive Length Register	0xC07A	R/W
HSS Transmit Address Register	0xC07C	R/W
HSS Transmit Length Register	0xC07E	R/W

HSS Control Register [0xC070] [R/W]

Table 90. HSS Control Register

Bit #	15	14	13	12	11	10	9	8
Field	HSS Enable	RTS Polarity Select	CTS Polarity Select	XOFF	XOFF Enable	CTS Enable	Receive Interrupt Enable	Done Interrupt Enable
Read/Write	R/W	R/W	R/W	R	R/W	R/W	R/W	R/W
Default	0	0	0	0	0	0	0	0

Bit #	7	6	5	4	3	2	1	0
Field	Transmit Done Interrupt Enable	Receive Done Interrupt Enable	One Stop Bit	Transmit Ready	Packet Mode Select	Receive Overflow Flag	Receive Packet Ready Flag	Receive Ready Flag
Read/Write	R/W	R/W	R/W	R	R/W	R/W	R	R
Default	0	0	0	0	0	0	0	0

Register Description

The HSS Control register provides high level status and control over the HSS port.

HSS Enable (Bit 15)

The HSS Enable bit enables or disables HSS operation.

- 1: Enables HSS operation
- 0: Disables HSS operation

RTS Polarity Select (Bit 14)

The RTS Polarity Select bit selects the polarity of RTS.

- 1: RTS is true when LOW
- 0: RTS is true when HIGH

CTS Polarity Select (Bit 13)

The CTS Polarity Select bit selects the polarity of CTS.

- 1: CTS is true when LOW
- 0: CTS is true when HIGH

XOFF (Bit 12)

The XOFF bit is a read only bit that indicates if an XOFF was received. This bit is automatically cleared when an XON is received.

- 1: XOFF received
- 0: XON received

XOFF Enable (Bit 11)

The XOFF Enable bit enables or disables XON/XOFF software handshaking.

- 1: Enable XON/XOFF software handshaking
- 0: Disable XON/XOFF software handshaking

CTS Enable (Bit 10)

The CTS Enable bit enables or disables CTS/RTS hardware handshaking.

- 1: Enable CTS/RTS hardware handshaking
- 0: Disable CTS/RTS hardware handshaking

Receive Interrupt Enable (Bit 9)

The Receive Interrupt Enable bit enables or disables the Receive Ready and Receive Packet Ready interrupts.

- 1: Enable the Receive Ready and Receive Packet Ready interrupts
- 0: Disable the Receive Ready and Receive Packet Ready interrupts

Done Interrupt Enable (Bit 8)

The Done Interrupt Enable bit enables or disables the Transmit Done and Receive Done interrupts.

- 1: Enable the Transmit Done and Receive Done interrupts
- 0: Disable the Transmit Done and Receive Done interrupts

Transmit Done Interrupt Flag (Bit 7)

The Transmit Done Interrupt Flag bit indicates the status of the Transmit Done Interrupt. It sets when a block transmit is finished. To clear the interrupt, write a '1' to this bit.

- 1: Interrupt triggered
- 0: Interrupt did not trigger

Receive Done Interrupt Flag (Bit 6)

The Receive Done Interrupt Flag bit indicates the status of the Receive Done Interrupt. It sets when a block transmit is finished. To clear the interrupt, write a '1' to this bit.

- 1: Interrupt triggered
- 0: Interrupt did not trigger

One Stop Bit (Bit 5)

The One Stop Bit bit selects between one and two stop bits for transmit byte mode. In receive mode, the number of stop bits may vary and does not need to be fixed.

- 1: One stop bit
- 0: Two stop bits

Transmit Ready (Bit 4)

The Transmit Ready bit is a read only bit that indicates if the HSS Transmit FIFO is ready for the CPU to load new data for transmission.

- 1: HSS transmit FIFO ready for loading
- 0: HSS transmit FIFO not ready for loading

Packet Mode Select (Bit 3)

The Packet Mode Select bit selects between Receive Packet Ready and Receive Ready as the interrupt source for the RxIntr interrupt.

- 1: Selects Receive Packet Ready as the source
- 0: Selects Receive Ready as the source

Receive Overflow Flag (Bit 2)

The Receive Overflow Flag bit indicates if the Receive FIFO overflowed when set. This flag can be cleared by writing a '1' to this bit.

- 1: Overflow occurred
- 0: Overflow did not occur

Receive Packet Ready Flag (Bit 1)

The Receive Packet Ready Flag bit is a read only bit that indicates if the HSS receive FIFO is full with eight bytes or not.

- 1: HSS receive FIFO is full
- 0: HSS receive FIFO is not full

Receive Ready Flag (Bit 0)

The Receive Ready Flag is a read only bit that indicates if the HSS receive FIFO is empty or not.

- 1: HSS receive FIFO is not empty (one or more bytes is reading for reading)
- 0: HSS receive FIFO is empty

HSS Baud Rate Register [0xC072] [R/W]

Table 91. HSS Baud Rate Register

Bit #	15	14	13	12	11	10	9	8
Field	Reserved			Baud...				
Read/Write	-	-	-	R/W	R/W	R/W	R/W	R/W
Default	0	0	0	0	0	0	0	0

Bit #	7	6	5	4	3	2	1	0
Field	...Baud							
Read/Write	R/W	R/W	R/W	R/W	R/W	R/W	R/W	R/W
Default	0	0	0	1	0	1	1	1

Register Description

The HSS Baud Rate register sets the HSS Baud Rate. At reset, the default value is 0x0017 which sets the baud rate to 2.0 MHz.

Reserved

Write all reserved bits with '0'.

Baud (Bits [12:0])

The Baud field is the baud rate divisor minus one, in units of 1/48 MHz. Therefore the Baud Rate = 48 MHz/(Baud + 1). This puts a constraint on the Baud Value as follows:
 $(24 - 1) \leq \text{Baud} \leq (5000 - 1)$

HSS Transmit Gap Register [0xC074] [R/W]

Table 92. HSS Transmit Gap Register

Bit #	15	14	13	12	11	10	9	8
Field	Reserved							
Read/Write	-	-	-	-	-	-	-	-
Default	0	0	0	0	0	0	0	0

Bit #	7	6	5	4	3	2	1	0
Field	Transmit Gap Select							
Read/Write	R/W	R/W	R/W	R/W	R/W	R/W	R/W	R/W
Default	0	0	0	0	1	0	0	1

Register Description

The HSS Transmit Gap register is only valid in block transmit mode. It allows for a programmable number of stop bits to be inserted, thus overwriting the One Stop Bit in the HSS Control register. The default reset value of this register is 0x0009, equivalent to two stop bits.

Reserved

Write all reserved bits with '0'.

Transmit Gap Select (Bits [7:0])

The Transmit Gap Select field sets the inactive time between transmitted bytes. The inactive time = (Transmit Gap Select – 7) * bit time. Therefore a Transmit Gap Select Value of 8 is equal to having one Stop bit.

HSS Data Register [0xC076] [R/W]

Table 93. HSS Data Register

Bit #	15	14	13	12	11	10	9	8
Field	Reserved							
Read/Write	-	-	-	-	-	-	-	-
Default	X	X	X	X	X	X	X	X

Bit #	7	6	5	4	3	2	1	0
Field	Data							
Read/Write	R/W	R/W	R/W	R/W	R/W	R/W	R/W	R/W
Default	X	X	X	X	X	X	X	X

Register Description

The HSS Data register contains data received on the HSS port (not for block receive mode) when read. This receive data is valid when the Receive Ready bit of the HSS Control register is set to '1'. Writing to this register initiates a single byte transfer of data. The Transmit Ready Flag in the HSS Control register must read '1' before writing to this register (this avoids disrupting the previous/current transmission).

Data (Bits [7:0])

The Data field contains the data received or to be transmitted on the HSS port.

Reserved

Write all reserved bits with '0'.

HSS Receive Address Register [0xC078] [R/W]

Table 94. HSS Receive Address Register

Bit #	15	14	13	12	11	10	9	8
Field	Address...							
Read/Write	R/W	R/W	R/W	R/W	R/W	R/W	R/W	R/W
Default	0	0	0	0	0	0	0	0

Bit #	7	6	5	4	3	2	1	0
Field	...Address							
Read/Write	R/W	R/W	R/W	R/W	R/W	R/W	R/W	R/W
Default	0	0	0	0	0	0	0	0

Register Description

The HSS Receive Address register is used as the base pointer address for the next HSS block receive transfer.

Address (Bits [15:0])

The Address field sets the base pointer address for the next HSS block receive transfer.

HSS Receive Counter Register [0xC07A] [R/W]

Table 95. HSS Receive Counter Register

Bit #	15	14	13	12	11	10	9	8
Field	Reserved						Counter...	
Read/Write	-	-	-	-	-	-	R/W	R/W
Default	0	0	0	0	0	0	0	0

Bit #	7	6	5	4	3	2	1	0
Field	...Counter							
Read/Write	R/W	R/W	R/W	R/W	R/W	R/W	R/W	R/W
Default	0	0	0	0	0	0	0	0

Register Description

The HSS Receive Counter register designates the block byte length for the next HSS receive transfer. Load this register with the word count minus one to start the block receive transfer. As each byte is received this register value is decremented. When read, this register indicates the remaining length of the transfer.

Counter (Bits [9:0])

The Counter field value is equal to the word count minus one giving a maximum value of 0x03FF (1023) or 2048 bytes. When the transfer is complete this register returns 0x03FF until reloaded.

Reserved

Write all reserved bits with '0'.

HSS Transmit Address Register [0xC07C] [R/W]
Table 96. HSS Transmit Address Register

Bit #	15	14	13	12	11	10	9	8
Field	Address...							
Read/Write	R/W	R/W	R/W	R/W	R/W	R/W	R/W	R/W
Default	0	0	0	0	0	0	0	0

Bit #	7	6	5	4	3	2	1	0
Field	...Address							
Read/Write	R/W	R/W	R/W	R/W	R/W	R/W	R/W	R/W
Default	0	0	0	0	0	0	0	0

Register Description

The HSS Transmit Address register is used as the base pointer address for the next HSS block transmit transfer.

Address (Bits [15:0])

The Address field sets the base pointer address for the next HSS block transmit transfer.

HSS Transmit Counter Register [0xC07E] [R/W]
Table 97. HSS Transmit Counter Register

Bit #	15	14	13	12	11	10	9	8
Field	Reserved						Counter...	
Read/Write	-	-	-	-	-	-	R/W	R/W
Default	0	0	0	0	0	0	0	0

Bit #	7	6	5	4	3	2	1	0
Field	...Counter							
Read/Write	R/W	R/W	R/W	R/W	R/W	R/W	R/W	R/W
Default	0	0	0	0	0	0	0	0

Register Description

The HSS Transmit Counter register designates the block byte length for the next HSS transmit transfer. Load this register with the word count minus one to start the block transmit transfer. As each byte is transmitted this register value is decremented. When read, this register indicates the remaining length of the transfer.

Counter (Bits [9:0])

The Counter field value is equal to the word count minus one giving a maximum value of 0x03FF (1023) or 2048 bytes. When the transfer is complete this register returns 0x03FF until reloaded.

Reserved

Write all reserved bits with '0'.

HPI Registers

There are five registers dedicated to HPI operation. In addition, there is an HPI status port which can be addressed over HPI. Each of these registers is covered in this section and are summarized in Table 98.

Table 98. HPI Registers

Register Name	Address	R/W
HPI Breakpoint Register	0x0140	R
Interrupt Routing Register	0x0142	R
SIE1msg Register	0x0144	W
SIE2msg Register	0x0148	W
HPI Mailbox Register	0xC0C6	R/W

HPI Breakpoint Register [0x0140] [R]

Table 99. HPI Breakpoint Register

Bit #	15	14	13	12	11	10	9	8
Field	Address...							
Read/Write	R	R	R	R	R	R	R	R
Default	0	0	0	0	0	0	0	0

Bit #	7	6	5	4	3	2	1	0
Field	...Address							
Read/Write	R	R	R	R	R	R	R	R
Default	0	0	0	0	0	0	0	0

Register Description

The HPI Breakpoint register is a special on-chip memory location that the external processor can access using normal HPI memory read/write cycles. This register is read only by the CPU but is read/write by the HPI port. The contents of this register have the same effect as the Breakpoint register [0xC014]. This special Breakpoint register is used by software debuggers that interface through the HPI port instead of the serial port.

When the program counter matches the Breakpoint Address, the INT127 interrupt triggers. To clear this interrupt, write a zero to this register.

Address (Bits [15:0])

The Address field is a 16-bit field containing the breakpoint address.

Interrupt Routing Register [0x0142] [R]

Table 100. Interrupt Routing Register

Bit #	15	14	13	12	11	10	9	8
Field	VBUS to HPI Enable	ID to HPI Enable	SOF/EOP2 to HPI Enable	SOF/EOP2 to CPU Enable	SOF/EOP1 to HPI Enable	SOF/EOP1 to CPU Enable	Reset2 to HPI Enable	HPI Swap 1 Enable
Read/Write	-	-	-	-	-	-	-	-
Default	0	0	0	1	0	1	0	0

Bit #	7	6	5	4	3	2	1	0
Field	Resume2 to HPI Enable	Resume1 to HPI Enable	Reserved		Done2 to HPI Enable	Done1 to HPI Enable	Reset1 to HPI Enable	HPI Swap 0 Enable
Read/Write	-	-	-	-	-	-	-	-
Default	0	0	0	0	0	0	0	0

Register Description

The Interrupt Routing register allows the HPI port to take over some or all of the SIE interrupts that usually go to the on-chip CPU. This register is read only by the CPU but is read/write by the HPI port. By setting the appropriate bit to '1', the SIE interrupt is routed to the HPI port to become the HPI_INTR signal and also readable in the HPI Status register. The bits in this register select

where the interrupts are routed. The individual interrupt enable is handled in the SIE interrupt enable register.

VBUS to HPI Enable (Bit 15)

The VBUS to HPI Enable bit routes the OTG VBUS interrupt to the HPI port instead of the on-chip CPU.

- 1:** Route signal to HPI port
- 0:** Do not route signal to HPI port

ID to HPI Enable (Bit 14)

The ID to HPI Enable bit routes the OTG ID interrupt to the HPI port instead of the on-chip CPU.

1: Route signal to HPI port

0: Do not route signal to HPI port

SOF/EOP2 to HPI Enable (Bit 13)

The SOF/EOP2 to HPI Enable bit routes the SOF/EOP2 interrupt to the HPI port.

1: Route signal to HPI port

0: Do not route signal to HPI port

SOF/EOP2 to CPU Enable (Bit 12)

The SOF/EOP2 to CPU Enable bit routes the SOF/EOP2 interrupt to the on-chip CPU. Since the SOF/EOP2 interrupt can be routed to both the on-chip CPU and the HPI port, the firmware must ensure only one of the two (CPU, HPI) resets the interrupt.

1: Route signal to CPU

0: Do not route signal to CPU

SOF/EOP1 to HPI Enable (Bit 11)

The SOF/EOP1 to HPI Enable bit routes the SOF/EOP1 interrupt to the HPI port.

1: Route signal to HPI port

0: Do not route signal to HPI port

SOF/EOP1 to CPU Enable (Bit 10)

The SOF/EOP1 to CPU Enable bit routes the SOF/EOP1 interrupt to the on-chip CPU. Since the SOF/EOP1 interrupt can be routed to both the on-chip CPU and the HPI port, the firmware must ensure only one of the two (CPU, HPI) resets the interrupt.

1: Route signal to CPU

0: Do not route signal to CPU

Reset2 to HPI Enable (Bit 9)

The Reset2 to HPI Enable bit routes the USB Reset interrupt that occurs on Device 2 to the HPI port instead of the on-chip CPU.

1: Route signal to HPI port

0: Do not route signal to HPI port

HPI Swap 1 Enable (Bit 8)

Both HPI Swap bits (bits 8 and 0) must be set to identical values. When set to '00', the most significant data byte goes to HPI_D[15:8] and the least significant byte goes to HPI_D[7:0]. This is the default setting. By setting to '11', the most significant data byte goes to HPI_D[7:0] and the least significant byte goes to HPI_D[15:8].

Resume2 to HPI Enable (Bit 7)

The Resume2 to HPI Enable bit routes the USB Resume interrupt that occurs on Host 2 to the HPI port instead of the on-chip CPU.

1: Route signal to HPI port

0: Do not route signal to HPI port

Resume1 to HPI Enable (Bit 6)

The Resume1 to HPI Enable bit routes the USB Resume interrupt that occurs on Host 1 to the HPI port instead of the on-chip CPU.

1: Route signal to HPI port

0: Do not route signal to HPI port

Done2 to HPI Enable (Bit 3)

The Done2 to HPI Enable bit routes the Done interrupt for Host/Device 2 to the HPI port instead of the on-chip CPU.

1: Route signal to HPI port

0: Do not route signal to HPI port

Done1 to HPI Enable (Bit 2)

The Done1 to HPI Enable bit routes the Done interrupt for Host/Device 1 to the HPI port instead of the on-chip CPU.

1: Route signal to HPI port

0: Do not route signal to HPI port

Reset1 to HPI Enable (Bit 1)

The Reset1 to HPI Enable bit routes the USB Reset interrupt that occurs on Device 1 to the HPI port instead of the on-chip CPU.

1: Route signal to HPI port

0: Do not route signal to HPI port

HPI Swap 0 Enable (Bit 0)

Both HPI Swap bits (bits 8 and 0) must be set to identical values. When set to '00', the most significant data byte goes to HPI_D[15:8] and the least significant byte goes to HPI_D[7:0]. This is the default setting. By setting to '11', the most significant data byte goes to HPI_D[7:0] and the least significant byte goes to HPI_D[15:8].

SIEXmsg Register [W]

- SIE1msg Register 0x0144 ^[15]
- SIE2msg Register 0x0148 ^[15]

Table 101. SIEXmsg Register

Bit #	15	14	13	12	11	10	9	8
Field	Data...							
Read/Write	W	W	W	W	W	W	W	W
Default	X	X	X	X	X	X	X	X

Bit #	7	6	5	4	3	2	1	0
Field	...Data							
Read/Write	W	W	W	W	W	W	W	W
Default	X	X	X	X	X	X	X	X

Register Description

The SIEXmsg register allows an interrupt to be generated on the HPI port. Any write to this register causes the SIEXmsg flag in the HPI Status Port to go high and also causes an interrupt on the HPI_INTR pin. The SIEXmsg flag is automatically cleared when the HPI port reads from this register.

Data (Bits [15:0])

The Data field[15:0] simply needs to have any value written to it to cause SIEXmsg flag in the HPI Status Port to go high.

HPI Mailbox Register [0xC0C6] [R/W]
Table 102. HPI Mailbox Register

Bit #	15	14	13	12	11	10	9	8
Field	Message...							
Read/Write	R/W	R/W	R/W	R/W	R/W	R/W	R/W	R/W
Default	0	0	0	0	0	0	0	0

Bit #	7	6	5	4	3	2	1	0
Field	...Message							
Read/Write	R/W	R/W	R/W	R/W	R/W	R/W	R/W	R/W
Default	0	0	0	0	0	0	0	0

Register Description

The HPI Mailbox register provides a common mailbox between the CY7C67300 and the external host processor.

If enabled, the HPI Mailbox RX Full interrupt triggers when the external host processor writes to this register. When the CY7C67300 reads this register the HPI Mailbox RX Full interrupt is automatically cleared.

If enabled, the HPI Mailbox TX Empty interrupt triggers when the external host processor reads from this register. The HPI Mailbox TX Empty interrupt automatically clears when the CY7C67300 writes to this register.

In addition, when the CY7C67300 writes to this register, the HPI_INTR signal on the HPI port asserts, signaling the external processor that there is data in the mailbox to read. The HPI_INTR signal deasserts when the external host processor reads from this register.

Message (Bits [15:0])

The Message field contains the message that the host processor wrote to the HPI Mailbox register.

Note

15. Errata: The SIE1msg and SIE2msg Registers [0x0144 and 0x0148] are not initialized at power up. Please refer to [Errata on page 107](#) for details and workaround.

HPI Status Port [] [HPI: R]

Table 103. HPI Status Port

Bit #	15	14	13	12	11	10	9	8
Field	VBUS Flag	ID Flag	Reserved	SOF/EOP2 Flag	Reserved	SOF/EOP1 Flag	Reset2 Flag	Mailbox In Flag
Read/Write	R	R	-	R	-	R	R	R
Default	X	X	X	X	X	X	X	X

Bit #	7	6	5	4	3	2	1	0
Field	Resume2 Flag	Resume1 Flag	SIE2msg	SIE1msg	Done2 Flag	Done1 Flag	Reset1 Flag	Mailbox Out Flag
Read/Write	R	R	R	R	R	R	R	R
Default	X	X	X	X	X	X	X	X

Register Description

The HPI Status Port provides the external host processor with the MailBox status bits plus several SIE status bits. This register is not accessible from the on-chip CPU. The additional SIE status bits are provided to aid external device driver firmware development, and are not recommended for applications that do not have an intimate relationship with the on-chip BIOS.

Reading from the HPI Status Port does not result in a CPU HPI interface memory access cycle. The external host may continuously poll this register without degrading the CPU or DMA performance.

VBUS Flag (Bit 15)

The VBUS Flag bit is a read only bit that indicates whether OTG VBus is greater than 4.4V. After turning on VBUS, firmware must wait at least 10 μ s before this reading this bit.

1: OTG VBus is greater than 4.4V

0: OTG VBus is less than 4.4V

ID Flag (Bit 14)

The ID Flag bit is a read only bit that indicates the state of the OTG ID pin.

SOF/EOP2 Flag (Bit 12)

The SOF/EOP2 Flag bit is a read only bit that indicates if a SOF/EOP interrupt occurs on either Host/Device 2.

1: Interrupt triggered

0: Interrupt did not trigger

SOF/EOP1 Flag (Bit 10)

The SOF/EOP1 Flag bit is a read only bit that indicates if a SOF/EOP interrupt occurs on either Host/Device 1.

1: Interrupt triggered

0: Interrupt did not trigger

Reset2 Flag (Bit 9)

The Reset2 Flag bit is a read only bit that indicates if a USB Reset interrupt occurs on either Host/Device 2.

1: Interrupt triggered

0: Interrupt did not trigger

Mailbox In Flag (Bit 8)

The Mailbox In Flag bit is a read only bit that indicates if a message is ready in the incoming mailbox. This interrupt clears when the on-chip CPU reads from the HPI Mailbox register.

1: Interrupt triggered

0: Interrupt did not trigger

Resume2 Flag (Bit 7)

The Resume2 Flag bit is a read only bit that indicates if a USB resume interrupt occurs on either Host/Device 2.

1: Interrupt triggered

0: Interrupt did not trigger

Resume1 Flag (Bit 6)

The Resume1 Flag bit is a read only bit that indicates if a USB resume interrupt occurs on either Host/Device 1.

1: Interrupt triggered

0: Interrupt did not trigger

SIE2msg (Bit 5)

The SIE2msg Flag bit is a read only bit that indicates if the CY7C67300 CPU wrote to the SIE2msg register. This bit is cleared on an HPI read.

1: The SIE2msg register was written by the CY7C67300 CPU

0: The SIE2msg register was not written by the CY7C67300 CPU

SIE1msg (Bit 4)

The SIE1msg Flag bit is a read only bit that indicates if the CY7C67300 CPU wrote to the SIE1msg register. This bit is cleared on an HPI read.

1: The SIE1msg register was written by the CY7C67300 CPU

0: The SIE1msg register was not written by the CY7C67300 CPU

Done2 Flag (Bit 3)

In host mode the Done2 Flag bit is a read only bit that indicates if a host packet done interrupt occurs on Host 2. In device mode this read only bit indicates if any of the endpoint interrupts occur on Device 2. Firmware needs to determine which endpoint interrupt occurred.

1: Interrupt triggered

0: Interrupt did not trigger

Done1 Flag (Bit 2)

In host mode the Done 1 Flag bit is a read only bit that indicates if a host packet done interrupt occurs on Host 1. In device mode this read only bit indicates if an any of the endpoint interrupts occur on Device 1. Firmware needs to determine which endpoint interrupt occurred.

1: Interrupt triggered

0: Interrupt did not trigger

Reset1 Flag (Bit 1)

The Reset1 Flag bit is a read only bit that indicates if a USB Reset interrupt occurs on either Host/Device 1.

1: Interrupt triggered

0: Interrupt did not trigger

Mailbox Out Flag (Bit 0)

The Mailbox Out Flag bit is a read only bit that indicates if a message is ready in the outgoing mailbox. This interrupt clears when the external host reads from the HPI Mailbox register.

1: Interrupt triggered

0: Interrupt did not trigger

SPI Registers

There are twelve registers dedicated to SPI operation. Each of these registers is covered in this section and summarized in [Table 104](#).

Table 104. SPI Registers

Register Name	Address	R/W
SPI Configuration Register	0xC0C8	R/W
SPI Control Register	0xC0CA	R/W
SPI Interrupt Enable Register	0xC0CC	R/W
SPI Status Register	0xC0CE	R
SPI Interrupt Clear Register	0xC0D0	W
SPI CRC Control Register	0xC0D2	R/W
SPI CRC Value	0xC0D4	R/W
SPI Data Register	0xC0D6	R/W
SPI Transmit Address Register	0xC0D8	R/W
SPI Transmit Count Register	0xC0DA	R/W
SPI Receive Address Register	0xC0DC	R/W
SPI Receive Count Register	0xC0DE	R/W

SPI Configuration Register [0xC0C8] [R/W]

Table 105. SPI Configuration Register

Bit #	15	14	13	12	11	10	9	8
Field	3Wire Enable	Phase Select	SCK Polarity Select	Scale Select				Reserved
Read/Write	R/W	R/W	R/W	R/W	R/W	R/W	R/W	-
Default	1	0	0	0	0	0	0	0

Bit #	7	6	5	4	3	2	1	0
Field	Master Active Enable	Master Enable	SS Enable	SS Delay Select				
Read/Write	R	R/W	R/W	R/W	R/W	R/W	R/W	R/W
Default	0	0	0	1	1	1	1	1

Register Description

The SPI Configuration register controls the SPI port. Fields apply to both master and slave mode unless otherwise noted.

3Wire Enable (Bit 15)

The 3Wire Enable bit indicates if the MISO and MOSI data lines are tied together allowing only half duplex operation.

- 1: MISO and MOSI data lines are tied together
- 0: Normal MISO and MOSI Full Duplex operation (not tied together)

Phase Select (Bit 14)

The Phase Select bit selects advanced or delayed SCK phase. This field only applies to master mode.

- 1: Advanced SCK phase
- 0: Delayed SCK phase

SCK Polarity Select (Bit 13)

This SCK Polarity Select bit selects the polarity of SCK.

- 1: Positive SCK polarity
- 0: Negative SCK polarity

Scale Select (Bits [12:9])

The Scale Select field provides control over the SCK frequency, based on 48 MHz. Refer to [Table 106](#) for a definition of this field. This field only applies to master mode.

Table 106. Scale Select Field Definition for SCK Frequency

Scale Select [12:9]	SCK Frequency
0000	12 MHz
0001	8 MHz
0010	6 MHz
0011	4 MHz
0100	3 MHz
0101	2 MHz
0110	1.5 MHz
0111	1 MHz
1000	750 KHz

Table 106. Scale Select Field Definition for SCK Frequency

Scale Select [12:9]	SCK Frequency
1001	500 KHz
1010	375 KHz
1011	250 KHz
1100	375 KHz
1101	250 KHz
1110	375 KHz
1111	250 KHz

Master Active Enable (Bit 7)

The Master Active Enable bit is a read only bit that indicates if the master state machine is active or idle. This field only applies to master mode.

- 1: Master state machine is active
- 0: Master state machine is idle

Master Enable (Bit 6)

The Master Enable bit sets the SPI interface to master or slave. This bit is only writable when the Master Active Enable bit reads '0', otherwise the value does not change.

- 1: Master SPI interface
- 0: Slave SPI interface

SS Enable (Bit 5)

The SS Enable bit enables or disables the master SS output.

- 1: Enable master SS output
- 0: Disable master SS output (three state master SS output, for single SS line in slave mode)

SS Delay Select (Bits [4:0])

When the SS Delay Select field is set to '00000' this indicates manual mode. In manual mode SS is controlled by the SS Manual bit of the SPI Control register. When the SS Delay Select field is set between '00001' to '11111', this value indicates the count in half bit times of auto transfer delay for: SS low to SCK active, SCK inactive to SS high, SS high time. This field only applies to master mode.

SPI Control Register [0xC0CA] [R/W]

Table 107. SPI Control Register

Bit #	15	14	13	12	11	10	9	8
Field	SCK Strobe	FIFO Init	Byte Mode	Full Duplex	SS Manual	Read Enable	Transmit Ready	Receive Data Ready
Read/Write	W	W	R/W	R/W	R/W	R/W	R	R
Default	0	0	0	0	0	0	0	1

Bit #	7	6	5	4	3	2	1	0
Field	Transmit Empty	Receive Full	Transmit Bit Length			Receive Bit Length		
Read/Write	R	R	R/W	R/W	R/W	R/W	R/W	R/W
Default	1	0	0	0	0	0	0	0

Register Description

The SPI Control register controls the SPI port. Fields apply to both master and slave mode unless otherwise noted.

SCK Strobe (Bit 15)

The SCK Strobe bit starts the SCK strobe at the selected frequency and polarity (set in the SPI Configuration register), but not phase. This bit feature can only be enabled when in master mode and must be during a period of inactivity. This bit is self clearing.

1: SCK Strobe Enable

0: No Function

FIFO Init (Bit 14)

The FIFO Init bit initializes the FIFO and clears the FIFO Error Status bit. This bit is self clearing.

1: FIFO Init Enable

0: No Function

Byte Mode (Bit 13)

The Byte Mode bit selects between PIO (byte mode) and DMA (block mode) operation.

1: Set PIO (byte mode) operation

0: Set DMA (block mode) operation

Full Duplex (Bit 12)

The Full Duplex bit selects between full duplex and half duplex operation.

1: Enable full duplex. Full duplex is not allowed and does not set if the 3Wire Enable bit of the SPI Configuration register is set to '1'

0: Enable half duplex operation

SS Manual (Bit 11)

The SS Manual bit activates or deactivates SS if the SS Delay Select field of the SPI Control register is all zeros and is configured as master interface. This field only applies to master mode.

1: Activate SS, master drives SS line asserted LOW

0: Deactivate SS, master drives SS line deasserted HIGH

Read Enable (Bit 10)

The Read Enable bit initiates a read phase for a master mode transfer or sets the slave to receive (in slave mode).

1: Initiates a read phase for a master transfer or sets a slave to receive. In master mode this bit is sticky and remains set until the read transfer begins.

0: Initiates the write phase for slave operation

Transmit Ready (Bit 9)

The Transmit Ready bit is a read only bit that indicates if the transmit port is ready to empty and ready to be written.

1: Ready for data to be written to the port. The transmit FIFO is not full.

0: Not ready for data to be written to the port

Receive Data Ready (Bit 8)

The Receive Data Ready bit is a read only bit that indicates if the receive port has data ready.

1: Receive port has data ready to read

0: Receive port does not have data ready

Transmit Empty (Bit 7)

The Transmit Empty bit is a read only bit that indicates if the transmit FIFO is empty.

1: Transmit FIFO is empty

0: Transmit FIFO is not empty

Receive Full (Bit 6)

The Receive Full bit is a read only bit that indicates if the receive FIFO is full.

1: Receive FIFO is full

0: Receive FIFO is not full

Transmit Bit Length (Bits [5:3])

The Transmit Bit Length field controls whether a full byte or partial byte is to be transmitted. If Transmit Bit Length is '000' then a full byte is transmitted. If Transmit Bit Length is '001' to '111', then the value indicates the number of bits that are being transmitted.

Receive Bit Length (Bits [2:0])

The Receive Bit Length field controls whether a full byte or partial byte is received. If Receive Bit Length is '000' then a full byte is received. If Receive Bit Length is '001' to '111', then the value indicates the number of bits that are received.

SPI Interrupt Enable Register [0xC0CC] [R/W]

Table 108. SPI Interrupt Enable Register

Bit #	15	14	13	12	11	10	9	8
Field	Reserved...							
Read/Write	-	-	-	-	-	-	-	-
Default	0	0	0	0	0	0	0	0

Bit #	7	6	5	4	3	2	1	0
Field	...Reserved					Receive Interrupt Enable	Transmit Interrupt Enable	Transfer Interrupt Enable
Read/Write	-	-	-	-	-	R/W	R/W	R/W
Default	0	0	0	0	0	0	0	0

Register Description

The SPI Interrupt Enable register controls the SPI port.

Receive Interrupt Enable (Bit 2)

The Receive Interrupt Enable bit enables or disables the byte mode receive interrupt (RxIntVal).

- 1: Enable byte mode receive interrupt
- 0: Disable byte mode receive interrupt

Transmit Interrupt Enable (Bit 1)

The Transmit Interrupt Enable bit enables or disables the byte mode transmit interrupt (TxIntVal).

- 1: Enables byte mode transmit interrupt
- 0: Disables byte mode transmit interrupt

Transfer Interrupt Enable (Bit 0)

The Transfer Interrupt Enable bit enables or disables the block mode interrupt (XfrBkIntVal).

- 1: Enables block mode interrupt
- 0: Disables block mode interrupt

Reserved

Write all reserved bits with '0'.

SPI Status Register [0xC0CE] [R]

Table 109. SPI Status Register

Bit #	15	14	13	12	11	10	9	8
Field	Reserved							
Read/Write	-	-	-	-	-	-	-	-
Default	0	0	0	0	0	0	0	0

Bit #	7	6	5	4	3	2	1	0
Field	FIFO Error Flag	Reserved				Receive Interrupt Flag	Transmit Interrupt Flag	Transfer Interrupt Flag
Read/Write	R	-	-	-	-	R	R	R
Default	0	0	0	0	0	0	0	0

Register Description

The SPI Status register is a read only register that provides status for the SPI port.

FIFO Error Flag (Bit 7)

The FIFO Error Flag bit is a read only bit that indicates if a FIFO error occurred. When this bit is set to '1' and the Transmit Empty

bit of the SPI Control register is set to '1', then a Tx FIFO underflow occurred. Similarly, when set with the Receive Full bit of the SPI Control register, an Rx FIFO overflow occurred. This bit automatically clears when the SPI FIFO Init Enable bit of the SPI Control register is set.

- 1: Indicates FIFO error
- 0: Indicates no FIFO error

Receive Interrupt Flag (Bit 2)

The Receive Interrupt Flag is a read only bit that indicates if a byte mode receive interrupt triggered.

- 1: Indicates a byte mode receive interrupt triggered
- 0: Indicates a byte mode receive interrupt did not trigger

Transmit Interrupt Flag (Bit 1)

The Transmit Interrupt Flag is a read only bit that indicates a byte mode transmit interrupt triggered.

- 1: Indicates a byte mode transmit interrupt triggered
- 0: Indicates a byte mode transmit interrupt did not trigger

Transfer Interrupt Flag (Bit 0)

The Transfer Interrupt Flag is a read only bit that indicates a block mode interrupt triggered.

- 1: Indicates a block mode interrupt triggered
- 0: Indicates a block mode interrupt did not trigger

SPI Interrupt Clear Register [0xC0D0] [W]

Table 110. SPI Interrupt Clear Register

Bit #	15	14	13	12	11	10	9	8
Field	Reserved							
Read/Write	-	-	-	-	-	-	-	-
Default	0	0	0	0	0	0	0	0

Bit #	7	6	5	4	3	2	1	0
Field	Reserved						Transmit Interrupt Clear	Transfer Interrupt Clear
Read/Write	-	-	-	-	-	-	W	W
Default	0	0	0	0	0	0	0	0

Register Description

The SPI Interrupt Clear register is a write only register that allows the SPI Transmit and SPI Transfer Interrupts to be cleared.

Transmit Interrupt Clear (Bit 1)

The Transmit Interrupt Clear bit is a write only bit that clears the byte mode transmit interrupt. This bit is self clearing.

- 1: Clear the byte mode transmit interrupt
- 0: No function

Transfer Interrupt Clear (Bit 0)

The Transfer Interrupt Clear bit is a write only bit that clears the block mode interrupt. This bit is self clearing.

- 1: Clear the block mode interrupt
- 0: No function

Reserved

Write all reserved bits with '0'.

SPI CRC Control Register [0xC0D2] [R/W]

Table 111. SPI CRC Control Register

Bit #	15	14	13	12	11	10	9	8
Field	CRC Mode		CRC Enable	CRC Clear	Receive CRC	One in CRC	Zero in CRC	Reserved...
Read/Write	R/W	R/W	R/W	R/W	R/W	R	R	-
Default	0	0	0	0	0	0	0	0

Bit #	7	6	5	4	3	2	1	0
Field	...Reserved							
Read/Write	-	-	-	-	-	-	-	-
Default	0	0	0	0	0	0	0	0

Register Description

The SPI CRC Control register provides control over the CRC source and polynomial value.

CRC Mode (Bits [15:14])

The CRCMode field selects the CRC polynomial as defined in [Table 112 on page 77](#).

Table 112. CRC Mode Definition

CRCMode [15:14]	CRC Polynomial
00	MMC 16 bit: $X^{16} + X^{12} + X^5 + 1$ (CCITT Standard)
01	CRC7 7 bit: $X^7 + X^3 + 1$
10	MST 16 bit: $X^{16} + X^{15} + X^2 + 1$
11	Reserved, 16 bit polynomial 1

CRC Enable (Bit 13)

The CRC Enable bit enables or disables the CRC operation.

1: Enables CRC operation

0: Disables CRC operation

CRC Clear (Bit 12)

The CRC Clear bit clears the CRC with a load of all ones. This bit is self clearing and always reads '0'.

1: Clear CRC with all ones

0: No Function

SPI CRC Value Register [0xC0D4] [R/W]

Table 113. SPI CRC Value Register

Bit #	15	14	13	12	11	10	9	8
Field	CRC...							
Read/Write	R/W	R/W	R/W	R/W	R/W	R/W	R/W	R/W
Default	1	1	1	1	1	1	1	1

Bit #	7	6	5	4	3	2	1	0
Field	...CRC							
Read/Write	R/W	R/W	R/W	R/W	R/W	R/W	R/W	R/W
Default	1	1	1	1	1	1	1	1

Register Description

The SPI CRC Value register contains the CRC value.

Receive CRC (Bit 11)

The Receive CRC bit determines whether the receive bit stream or the transmit bit stream is used for the CRC data input in full duplex mode. This bit is a don't care in half duplex mode.

1: Assigns the receive bit stream

0: Assigns the transmit bit stream

One in CRC (Bit 10)

The One in CRC bit is a read only bit that indicates if the CRC value is all zeros or not

1: CRC value is not all zeros

0: CRC value is all zeros

Zero in CRC (Bit 9)

The Zero in CRC bit is a read only bit that indicates if the CRC value is all ones or not.

1: CRC value is not all ones

0: CRC value is all ones

Reserved

Write all reserved bits with '0'.

CRC (Bits [15:0])

The CRC field contains the SPI CRC. In CRC Mode CRC7, the CRC value is a seven bit value [6:0]. Therefore, bits [15:7] are invalid in CRC7 mode.

SPI Data Register [0xC0D6] [R/W]
Table 114. SPI Data Register

Bit #	15	14	13	12	11	10	9	8
Field	Reserved							
Read/Write	-	-	-	-	-	-	-	-
Default	X	X	X	X	X	X	X	X

Bit #	7	6	5	4	3	2	1	0
Field	Data							
Read/Write	R/W	R/W	R/W	R/W	R/W	R/W	R/W	R/W
Default	X	X	X	X	X	X	X	X

Register Description

The SPI Data register contains data received on the SPI port when read. Reading it empties the eight byte receive FIFO in PIO byte mode. This receive data is valid when the Receive Interrupt Bit of the SPI Status register is set to '1' (RxIntVal triggers) or the Receive Data Ready bit of the SPI Control register is set to '1'. Writing to this register in PIO byte mode initiates a transfer of data, the number of bits defined by Transmit Bit Length field in the SPI Control register.

Data (Bits [7:0])

The Data field contains data received or to be transmitted on the SPI port.

Reserved

Write all reserved bits with '0'.

SPI Transmit Address Register [0xC0D8] [R/W]
Table 115. SPI Transmit Address Register

Bit #	15	14	13	12	11	10	9	8
Field	Address...							
Read/Write	R/W	R/W	R/W	R/W	R/W	R/W	R/W	R/W
Default	0	0	0	0	0	0	0	0

Bit #	7	6	5	4	3	2	1	0
Field	...Address							
Read/Write	R/W	R/W	R/W	R/W	R/W	R/W	R/W	R/W
Default	0	0	0	0	0	0	0	0

Register Description

The SPI Transmit Address register is used as the base address for the SPI transmit DMA.

Address (Bits [15:0])

The Address field sets the base address for the SPI transmit DMA.

SPI Transmit Count Register [0xC0DA] [R/W]
Table 116. SPI Transmit Count Register

Bit #	15	14	13	12	11	10	9	8	
Field	Reserved					Count...			
Read/Write	-	-	-	-	-	R/W	R/W	R/W	
Default	0	0	0	0	0	0	0	0	

Bit #	7	6	5	4	3	2	1	0
Field	...Count							
Read/Write	R/W	R/W	R/W	R/W	R/W	R/W	R/W	R/W
Default	0	0	0	0	0	0	0	0

Register Description

The SPI Transmit Count register designates the block byte length for the SPI transmit DMA transfer.

Reserved

Write all reserved bits with '0'.

Count (Bits [10:0])

The Count field sets the count for the SPI transmit DMA transfer.

SPI Receive Address Register [0xC0DC] [R/W]
Table 117. SPI Receive Address Register

Bit #	15	14	13	12	11	10	9	8
Field	Address...							
Read/Write	R/W	R/W	R/W	R/W	R/W	R/W	R/W	R/W
Default	0	0	0	0	0	0	0	0

Bit #	7	6	5	4	3	2	1	0
Field	...Address							
Read/Write	R/W	R/W	R/W	R/W	R/W	R/W	R/W	R/W
Default	0	0	0	0	0	0	0	0

Register Description

The SPI Receive Address register is issued as the base address for the SPI Receive DMA.

Address (Bits [15:0])

The Address field sets the base address for the SPI receive DMA.

SPI Receive Count Register [0xC0DE] [R/W]
Table 118. SPI Receive Count Register

Bit #	15	14	13	12	11	10	9	8	
Field	Reserved					Count...			
Read/Write	-	-	-	-	-	R/W	R/W	R/W	
Default	0	0	0	0	0	0	0	0	

Bit #	7	6	5	4	3	2	1	0
Field	...Count							
Read/Write	R/W	R/W	R/W	R/W	R/W	R/W	R/W	R/W
Default	0	0	0	0	0	0	0	0

Register Description

The SPI Receive Count register designates the block byte length for the SPI receive DMA transfer.

Count (Bits [10:0])

The Count field sets the count for the SPI receive DMA transfer.

Reserved

Write all reserved bits with '0'.

UART Registers

There are three registers dedicated to UART operation. Each of these registers is covered in this section and summarized in [Table 119](#).

Table 119. UART Registers

Register Name	Address	R/W
UART Control Register	0xC0E0	R/W
UART Status Register	0xC0E2	R
UART Data Register	0xC0E4	R/W

UART Control Register [0xC0E0] [R/W]

Table 120. UART Control Register

Bit #	15	14	13	12	11	10	9	8
Field	Reserved...							
Read/Write	-	-	-	-	-	-	-	-
Default	0	0	0	0	0	0	0	0

Bit #	7	6	5	4	3	2	1	0
Field	...Reserved			Scale Select	Baud Select			UART Enable
Read/Write	-	-	-	R/W	R/W	R/W	R/W	R/W
Default	0	0	0	0	0	1	1	1

Register Description

The UART Control register enables or disables the UART, allowing GPIO28 (UART_TXD) and GPIO27 (UART_RXD) to be freed up for general use. This register must also be written to set the baud rate, which is based on a 48 MHz clock.

Scale Select (Bit 4)

The Scale Select bit acts as a prescaler that divide the baud rate by eight.

1: Enable prescaler

0: Disable prescaler

Baud Select (Bits [3:1])

Refer to [Table 121](#) for a definition of this field.

Table 121. UART Baud Select Definition

Baud Select [3:1]	Baud Rate w/ DIV8 = 0	Baud Rate w/ DIV8 = 1
000	115.2 KBaud	14.4 KBaud
001	57.6 KBaud	7.2 KBaud
010	38.4 KBaud	4.8 KBaud
011	28.8 KBaud	3.6 KBaud
100	19.2 KBaud	2.4 KBaud
101	14.4 KBaud	1.8 KBaud
110	9.6 KBaud	1.2 KBaud
111	7.2 KBaud	0.9 KBaud

UART Enable (Bit 0)

The UART Enable bit enables or disables the UART.

1: Enable UART

0: Disable UART. This allows GPIO28 and GPIO27 to be used for general use.

Reserved

Write all reserved bits with '0'.

UART Status Register [0xC0E2] [R]

Table 122. UART Status Register

Bit #	15	14	13	12	11	10	9	8
Field	Reserved...							
Read/Write	-	-	-	-	-	-	-	-
Default	0	0	0	0	0	0	0	0

Bit #	7	6	5	4	3	2	1	0
Field	...Reserved						Receive Full	Transmit Full
Read/Write	-	-	-	-	-	-	R	R
Default	0	0	0	0	0	0	0	0

Register Description

The UART Status register is a read only register that indicates the status of the UART buffer.

Receive Full (Bit 1)

The Receive Full bit indicates whether the receive buffer is full. It can be programmed to interrupt the CPU as interrupt #5 when the buffer is full. This can be done through the UART bit of the Interrupt Enable register (0xC00E). This bit is automatically cleared when data is read from the UART Data register.

1: Receive buffer full

0: Receive buffer empty

Transmit Full (Bit 0)

The Transmit Full bit indicates whether the transmit buffer is full. It can be programmed to interrupt the CPU as interrupt #4 when the buffer is empty. This can be done through the UART bit of the Interrupt Enable register (0xC00E). This bit is automatically set to '1' after data is written by EZ-Host to the UART Data register (to be transmitted). This bit is automatically cleared to '0' after the data is transmitted.

1: Transmit buffer full (transmit busy)

0: Transmit buffer is empty and ready for a new byte of data

UART Data Register [0xC0E4] [R/W]

Table 123. UART Data Register

Bit #	15	14	13	12	11	10	9	8
Field	Reserved							
Read/Write	-	-	-	-	-	-	-	-
Default	0	0	0	0	0	0	0	0

Bit #	7	6	5	4	3	2	1	0
Field	Data							
Read/Write	R/W	R/W	R/W	R/W	R/W	R/W	R/W	R/W
Default	0	0	0	0	0	0	0	0

Register Description

The UART Data register contains data to be transmitted or received from the UART port. Data written to this register starts a data transmission and also causes the UART Transmit Full Flag of the UART Status register to set. When data received on the UART port is read from this register, the UART Receive Full Flag of the UART Status register is cleared.

Data (Bits [7:0])

The Data field is where the UART data to be transmitted or received is located.

Reserved

Write all reserved bits with '0'.

PWM Registers

There are eleven registers dedicated to PWM operation. Each of these registers are covered in this section and summarized in [Table 124](#).

Table 124. PWM Registers

Register Name	Address	R/W
PWM Control Register	0xC0E6	R/W
PWM Maximum Count Register	0xC0E8	R/W
PWM0 Start Register	0xC0EA	R/W
PWM0 Stop Register	0xC0EC	R/W
PWM1 Start Register	0xC0EE	R/W
PWM1 Stop Register	0xC0F0	R/W
PWM2 Start Register	0xC0F2	R/W
PWM2 Stop Register	0xC0F4	R/W
PWM3 Start Register	0xC0F6	R/W
PWM3 Stop Register	0xC0F8	R/W
PWM Cycle Count Register	0xC0FA	R/W

PWM Control Register [0xC0E6] [R/W]

Table 125. PWM Control Register

Bit #	15	14	13	12	11	10	9	8
Field	PWM Enable	Reserved			Prescale Select			Mode Select
Read/Write	R/W	-	-	-	R/W	R/W	R/W	R/W
Default	0	0	0	0	0	0	0	0

Bit #	7	6	5	4	3	2	1	0
Field	PWM 3 Polarity Select	PWM 2 Polarity Select	PWM 1 Polarity Select	PWM 0 Polarity Select	PWM 3 Enable	PWM 2 Enable	PWM 1 Enable	PWM 0 Enable
Read/Write	R/W	R/W	R/W	R/W	R/W	R/W	R/W	R/W
Default	0	0	0	0	0	0	0	0

Register Description

The PWM Control register provides high level control over all four of the PWM channels.

PWM Enable (Bit 15)

The PWM Enable bit starts and stops PWM operation.

1: Start operation

0: Stop operation

Prescale Select (Bits [11:9])

The Prescale Select field sets the frequency of all the PWM channels as defined in [Table 126](#).

Table 126. Prescaler Select Definition

Prescale Select [11:9]	Frequency
000	48.00 MHz
001	24.00 MHz
010	06.00 MHz
011	01.50 MHz
100	375 kHz
101	93.80 kHz
110	23.40 kHz
111	05.90 kHz

Mode Select (Bit 8)

The Mode Select bit selects between continuous PWM cycling and one shot mode. The default is continuous repeat.

1: Enable One Shot mode. The mode runs the number of counter cycles set in the PWM Cycle Count register and then stops.

0: Enable Continuous mode. Runs in continuous mode and starts over after the PWM cycle count is reached.

PWM 3 Polarity Select (Bit 7)

The PWM 3 Polarity Select bit selects the polarity for PWM 3.

1: Sets the polarity to active HIGH or rising edge pulse

0: Sets the polarity to active LOW

PWM 2 Polarity Select (Bit 6)

The PWM 2 Polarity Select bit selects the polarity for PWM 2.

1: Sets the polarity to active HIGH or rising edge pulse

0: Sets the polarity to active LOW

PWM 1 Polarity Select (Bit 5)

The PWM 1 Polarity Select bit selects the polarity for PWM 1.

1: Sets the polarity to active HIGH or rising edge pulse

0: Sets the polarity to active LOW

PWM 0 Polarity Select (Bit 4)

The PWM 0 Polarity Select bit selects the polarity for PWM 0.

1: Sets the polarity to active HIGH or rising edge pulse

0: Sets the polarity to active LOW

PWM 3 Enable (Bit 3)

The PWM 3 Enable bit enables or disables PWM 3.

1: Enable PWM 3

0: Disable PWM 3

PWM 2 Enable (Bit 2)

The PWM 2 Enable bit enables or disables PWM 2.

1: Enable PWM 2

0: Disable PWM 2

PWM 1 Enable (Bit 1)

The PWM 1 Enable bit enables or disables PWM 1.

1: Enable PWM 1

0: Disable PWM 1

PWM 0 Enable (Bit 0)

The PWM 0 Enable bit enables or disables PWM 0.

1: Enable PWM 0

0: Disable PWM 0

PWM Maximum Count Register [0xC0E8] [R/W]

Table 127. PWM Maximum Count Register

Bit #	15	14	13	12	11	10	9	8
Field	Reserved						Count...	
Read/Write	-	-	-	-	-	-	R/W	R/W
Default	0	0	0	0	0	0	0	0

Bit #	7	6	5	4	3	2	1	0
Field	...Count							
Read/Write	R/W	R/W	R/W	R/W	R/W	R/W	R/W	R/W
Default	0	0	0	0	0	0	0	0

Register Description

The PWM Maximum Count register designates the maximum window for each pulse cycle. Each count tick is based on the clock frequency set in the PWM Control register.

Count (Bits [9:0])

The Count field sets the maximum cycle time.

Reserved

Write all reserved bits with '0'.

PWM n Start Register [R/W]

- PWM 0 Start Register 0xC0EA
- PWM 1 Start Register 0xC0EE
- PWM 2 Start Register 0xC0F2
- PWM 3 Start Register 0xC0F6

Table 128. PWM n Start Register

Bit #	15	14	13	12	11	10	9	8
Field	Reserved						Address...	
Read/Write	-	-	-	-	-	-	R/W	R/W
Default	0	0	0	0	0	0	0	0

Bit #	7	6	5	4	3	2	1	0
Field	...Address							
Read/Write	R/W	R/W	R/W	R/W	R/W	R/W	R/W	R/W
Default	0	0	0	0	0	0	0	0

Register Description

The PWM n Start register designates where in the window defined by the PWM Maximum Count register to start the PWM pulse for a supplied channel.

Address (Bits [9:0])

The Address field designates when to start the PWM pulse. If this start value is equal to the Stop Count Value then the output stays at false.

Reserved

Write all reserved bits with '0'.

PWM n Stop Register [R/W]

- PWM 0 Stop Register 0xC0EC
- PWM 1 Stop Register 0xC0F0
- PWM 2 Stop Register 0xC0F4
- PWM 3 Stop Register 0xC0F8

Table 129. PWM n Stop Register

Bit #	15	14	13	12	11	10	9	8
Field	Reserved						Address...	
Read/Write	-	-	-	-	-	-	R/W	R/W
Default	0	0	0	0	0	0	0	0

Bit #	7	6	5	4	3	2	1	0
Field	...Address							
Read/Write	R/W	R/W	R/W	R/W	R/W	R/W	R/W	R/W
Default	0	0	0	0	0	0	0	0

Register Description

The PWM n Stop register designates where in the window defined by the PWM Maximum Count register to stop the PWM pulse for a supplied channel.

stays at '0'. If the PWM Stop value is greater than the PWM Maximum Count value then the output stays at true.

Reserved

Write all reserved bits with '0'.

Address (Bits [9:0])

The Address field designates when to stop the PWM pulse. If the PWM Start value is equal to the PWM Stop value then the output

PWM Cycle Count Register [0xC0FA] [R/W]
Table 130. PWM Cycle Count Register

Bit #	15	14	13	12	11	10	9	8
Field	Count...							
Read/Write	R/W	R/W	R/W	R/W	R/W	R/W	R/W	R/W
Default	0	0	0	0	0	0	0	0

Bit #	7	6	5	4	3	2	1	0
Field	...Count							
Read/Write	R/W	R/W	R/W	R/W	R/W	R/W	R/W	R/W
Default	0	0	0	0	0	0	0	0

Register Description

The PWM Cycle Count register designates the number of cycles to run when in one shot mode. One shot mode is enabled by setting the Mode Select bit of the PWM Control register to '1'.

Count (Bits [9:0])

The Count field designates the number of cycles (plus one) to run when in one shot mode. For example, Cycles = PWM Cycle Count + 1, therefore for two cycles set PWM Cycle Count = 1.

Pin Diagram

Figure 11. EZ-Host Pin Diagram

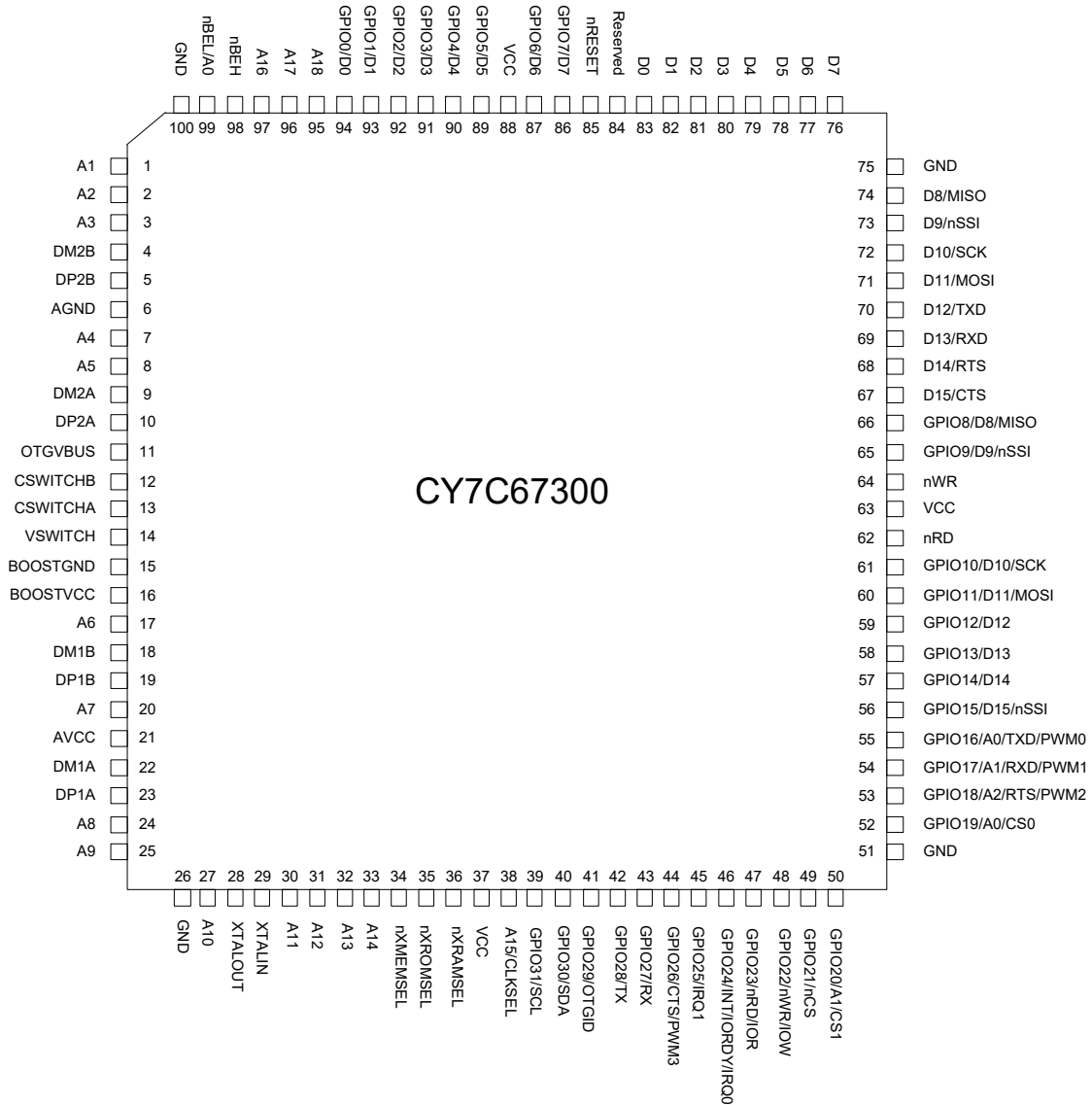

Pin Descriptions

Table 131. Pin Descriptions

Pin	Name	Type	Description
67	D15/CTS	IO	D15: External Memory Data Bus CTS: HSS CTS
68	D14/RTS	IO	D14: External Memory Data Bus RTS: HSS RTS
69	D13/RXD	IO	D13: External Memory Data Bus RXD: HSS RXD (Data is received on this pin)
70	D12/TXD	IO	D12: External Memory Data Bus TXD: HSS TXD (Data is transmitted from this pin)

Table 131. Pin Descriptions (Continued)

Pin	Name	Type	Description
71	D11/MOSI	IO	D11: External Memory Data Bus MOSI: SPI MOSI
72	D10/SCK	IO	D10: External Memory Data Bus SCK: SPI SCK
73	D9/nSSI	IO	D9: External Memory Data Bus nSSI: SPI nSSI
74	D8/MISO	IO	D8: External Memory Data Bus MISO: SPI MISO
76	D7	IO	External Memory Data Bus
77	D6	IO	
78	D5	IO	
79	D4	IO	
80	D3	IO	
81	D2	IO	
82	D1	IO	
83	D0	IO	
33	A14	Output	External Memory Address Bus
32	A13	Output	
31	A12	Output	
30	A11	Output	
27	A10	Output	
25	A9	Output	
24	A8	Output	
20	A7	Output	
17	A6	Output	
8	A5	Output	
7	A4	Output	
3	A3	Output	
2	A2	Output	
1	A1	Output	
99	nBEL/A0	Output	nBEL: Low Byte Enable for 16-bit memories A0: External Memory Address bit A0 for 0-8 bit memories
98	nBEH	Output	High Byte Enable for 16-bit memories
64	nWR	Output	External Memory Write pulse
62	nRD	Output	External Memory Read pulse
97	A16	Output	A16: External SRAM A16
96	A17	Output	A17: External SRAM A17
95	A18	Output	A18: External SRAM A18
34	nXMEMSEL	Output	External Memory Select 0
35	nXROMSEL	Output	External Memory Select 1
36	nXRAMSEL	Output	External Memory Select 2
38	A15/CLKSEL	IO	A15: External SRAM A15 CLKSEL: Sampled directly after reset to determine what crystal or clock source frequency is being used. 12 MHz is required for normal operation so the CLKSEL pin must have a 47K ohm pull up to V _{CC} . After reset this pin functions as A15.
39	GPIO31/SCK	IO	GPIO31: General Purpose IO SCK: I2C EEPROM SCK
40	GPIO30/SDA	IO	GPIO30: General Purpose IO SDA: I2C EEPROM SDA

Table 131. Pin Descriptions (Continued)

Pin	Name	Type	Description
41	GPIO29/OTGID	IO	GPIO29: General Purpose IO OTGID: Input for OTG ID pin. When used as OTGID, tie this pin high through an external pull up resistor. Assuming $V_{CC} = 3.0V$, a 10K to 40K resistor must be used.
42	GPIO28/TX	IO	GPIO28: General Purpose IO TX: UART TX (Data is transmitted from this pin)
43	GPIO27/RX	IO	GPIO27: General Purpose IO RX: UART RX (Data is received on this pin)
44	GPIO26/CTS/PWM3	IO	GPIO26: General Purpose IO CTS: HSS CTS PWM3: PWM channel 3
45	GPIO25/IRQ1	IO	GPIO25: General Purpose IO IRQ1: Interrupt Request 1. See Register 0xC006. This pin is also one of two possible GPIO wakeup sources.
46	GPIO24/INT/ IORDY/IRQ0	IO	GPIO24: General Purpose IO INT: HPI INT IORDY: IDE IORDY IRQ0: Interrupt Request 0. See Register 0xC006. This pin is also one of two possible GPIO wakeup sources.
47	GPIO23/nRD/IOR	IO	GPIO23: General Purpose IO nRD: HPI nRD IOR: IDE IOR
48	GPIO22/nWR/IOW	IO	GPIO22: General Purpose IO nWR: HPI nWR IOW: IDE IOW
49	GPIO21/nCS	IO	GPIO21: General Purpose IO nCS: HPI nCS
50	GPIO20/A1/CS1	IO	GPIO20: General Purpose IO A1: HPI A1 CS1: IDE CS1
52	GPIO19/A0/CS0	IO	GPIO19: General Purpose IO A0: HPI A0 CS0: IDE CS0
53	GPIO18/A2/RTS/ PWM2	IO	GPIO18: General Purpose IO A2: IDE A2 RTS: HSS RTS PWM2: PWM channel 2
54	GPIO17/A1/RXD/ PWM1	IO	GPIO17: General Purpose IO A1: IDE A1 RXD: HSS RXD (Data is received on this pin) PWM1: PWM channel 1
55	GPIO16/A0/TXD/ PWM0	IO	GPIO16: General Purpose IO A0: IDE A0 TXD: HSS TXD (Data is transmitted from this pin) PWM0: PWM channel 0
56	GPIO15/D15/nSSI	IO	GPIO15: General Purpose IO D15: D15 for HPI or IDE nSSI: SPI nSSI
57	GPIO14/D14	IO	GPIO14: General Purpose IO D14: D14 for HPI or IDE
58	GPIO13/D13	IO	GPIO13: General Purpose IO D13: D13 for HPI or IDE
59	GPIO12/D12	IO	GPIO12: General Purpose IO D12: D12 for HPI or IDE

Table 131. Pin Descriptions (Continued)

Pin	Name	Type	Description
60	GPIO11/D11/MOSI	IO	GPIO11: General Purpose IO D11: D11 for HPI or IDE MOSI: SPI MOSI
61	GPIO10/D10/SCK	IO	GPIO10: General Purpose IO D10: D10 for HPI or IDE SCK: SPI SCK
65	GPIO9/D9/nSSI	IO	GPIO9: General Purpose IO D9: D9 for HPI or IDE nSSI: SPI nSSI
66	GPIO8/D8/MISO	IO	GPIO8: General Purpose IO D8: D8 for HPI or IDE MISO: SPI MISO
86	GPIO7/D7	IO	GPIO7: General Purpose IO D7: D7 for HPI or IDE
87	GPIO6/D6	IO	GPIO6: General Purpose IO D6: D6 for HPI or IDE
89	GPIO5/D5	IO	GPIO5: General Purpose IO D5: D5 for HPI or IDE
90	GPIO4/D4	IO	GPIO4: General Purpose IO D4: D4 for HPI or IDE
91	GPIO3/D3	IO	GPIO3: General Purpose IO D3: D3 for HPI or IDE
92	GPIO2/D2	IO	GPIO2: General Purpose IO D2: D2 for HPI or IDE
93	GPIO1/D1	IO	GPIO1: General Purpose IO D1: D1 for HPI or IDE
94	GPIO0/D0	IO	GPIO0: General Purpose IO D0: D0 for HPI or IDE
22	DM1A	IO	USB Port 1A D-
23	DP1A	IO	USB Port 1A D+
18	DM1B	IO	USB Port 1B D-
19	DP1B	IO	USB Port 1B D+
9	DM2A	IO	USB Port 2A D-
10	DP2A	IO	USB Port 2A D+
4	DM2B	IO	USB Port 2B D-
5	DP2B	IO	USB Port 2B D+
29	XTALIN	Input	Crystal input or Direct Clock input
28	XTALOUT	Output	Crystal output. Leave floating if direct clock source is used.
85	nRESET	Input	Reset
84	Reserved	-	Tie to Gnd for normal operation.
16	BOOSTV _{CC}	Power	Booster Power input: 2.7V to 3.6V
14	VSWITCH	Analog Output	Booster switching output
15	BOOSTGND	Ground	Booster Ground
11	OTGVBUS	Analog IO	USB OTG Vbus
13	CSWITCHA	Analog	Charge Pump Capacitor
12	CSWITCHB	Analog	Charge Pump Capacitor
21	AV _{CC}	Power	USB Power
6	AGND	Ground	USB Ground
37, 63, 88	V _{CC}	Power	Main V _{CC}
26, 51, 75, 100	GND	Ground	Main Ground

Absolute Maximum Ratings

This section lists the absolute maximum ratings. Stresses above those listed can cause permanent damage to the device.

Exposure to maximum rated conditions for extended periods can affect device operation and reliability.

Storage Temperature	-40°C to +125°C
Ambient Temperature with Power Supplied..	-40°C to +85°C
Supply Voltage to Ground Potential.....	0.0V to +3.6V
DC Input Voltage to Any General Purpose Input Pin	5.5V
DC Voltage Applied to XTALIN	-0.5V to $V_{CC} + 0.5V$
Static Discharge Voltage	> 2000V
Max Output Current, per IO	4 mA

Operating Conditions

T_A (Ambient Temperature Under Bias)	-40°C to +85°C
Supply Voltage (V_{CC} , AV_{CC})	+3.0V to +3.6V
Supply Voltage (Boost V_{CC}) ^[16]	+2.7V to +3.6V
Ground Voltage.....	0V
F_{OSC} (Oscillator or Crystal Frequency)....	12 MHz \pm 500 ppm
.....	Parallel Resonant

Crystal Requirements (XTALIN, XTALOUT)

Table 132. Crystal Requirements

Crystal Requirements (XTALIN, XTALOUT)	Min	Typical	Max	Unit
Parallel Resonant Frequency		12		MHz
Frequency Stability	-500		+500	PPM
Load Capacitance	20		33	pF
Driver Level			500	μ W
Startup Time			5	ms
Mode of Vibration: Fundamental				

DC Characteristics

Table 133. DC Characteristics ^[17]

Parameter	Description	Conditions	Min	Typ.	Max	Unit
V_{CC} , AV_{CC}	Supply Voltage		3.0	3.3	3.6	V
Boos V_{CC}	Supply Voltage		2.7		3.6	V
V_{IH}	Input HIGH Voltage		2.0		5.5	V
V_{IL}	Input LOW Voltage				0.8	V
I_I	Input Leakage Current	$0 < V_{IN} < V_{CC}$	-10.0		+10.0	μ A
V_{OH}	Output Voltage HIGH	$I_{OUT} = 4$ mA	2.4			V
V_{OL}	Output LOW Voltage	$I_{OUT} = -4$ mA			0.4	V
I_{OH}	Output Current HIGH			10	20	mA
I_{OL}	Output Current LOW			10	20	mA
C_{IN}	Input Pin Capacitance	Except D+/D-			10	pF
		D+/D-			15	pF
V_{HYS}	Hysteresis on nReset Pin		250			mV
I_{CC} ^[18, 19]	Supply Current	4 transceivers powered		80	100	mA
I_{CCB} ^[18, 19]	Supply Current with Booster Enabled	4 transceivers powered		135	180	mA

Notes

16. The on-chip voltage booster circuit boosts Boost V_{CC} to provide a nominal 3.3V V_{CC} supply.
 17. All tests were conducted with Charge pump off.

Table 133. DC Characteristics (Continued)^[17]

Parameter	Description	Conditions	Min	Typ.	Max	Unit
I _{SLEEP}	Sleep Current	USB Peripheral: includes 1.5K internal pull up		210	500	μA
		Without 1.5K internal pull up		5	30	μA
I _{SLEEPB}	Sleep Current with Booster Enabled	USB Peripheral: includes 1.5K internal pull up		190	500	μA
		Without 1.5K internal pull up		5	30	μA

Table 134. DC Characteristics: Charge Pump

Parameter	Description	Conditions	Min	Typ.	Max	Unit
V _{A_VBUS_OUT}	Regulated OTGVBUS Voltage	8 mA < I _{LOAD} < 10 mA	4.4		5.25	V
T _{A_VBUS_RISE}	V _{BUS} Rise Time	I _{LOAD} = 10 mA			100	ms
I _{A_VBUS_OUT}	Maximum Load Current		8		10	mA
C _{DRD_VBUS}	OUTVBUS Bypass Capacitance	4.4V < V _{BUS} < 5.25V	1.0		6.5	pF
V _{A_VBUS_LKG}	OTGVBUS Leakage Voltage	OTGVBUS not driven			200	mV
V _{DRD_DATA_LKG}	Dataline Leakage Voltage				342	mV
I _{CHARGE}	Charge Pump Current Draw	I _{LOAD} = 8 mA		20	20	mA
		I _{LOAD} = 0 mA		0	1	mA
I _{CHARGE B}	Charge Pump Current Draw with Booster Active	I _{LOAD} = 8 mA		30	45	mA
		I _{LOAD} = 0 mA		0	5	mA
I _{B_DSCHG_IN}	B-Device (SRP Capable) Discharge Current	0V < V _{BUS} < 5.25V			8	mA
V _{A_VBUS_VALID}	A-Device VBUS Valid		4.4			V
V _{A_SESS_VALID}	A-Device Session Valid		0.8		2.0	V
V _{B_SESS_VALID}	B-Device Session Valid		0.8		4.0	V
V _{A_SESS_END}	B-Device Session End		0.2		0.8	V
E	Efficiency When Loaded	I _{LOAD} = 8 mA, V _{CC} = 3.3V		75		%
R _{PD}	Data Line Pull Down		14.25		24.8	Ω
R _{A_BUS_IN}	A-device V _{BUS} Input Impedance to GND	V _{BUS} is not being driven	40		100	kΩ
R _{B_SRP_UP}	B-device V _{BUS} SRP Pull Up	Pull up voltage = 3.0V	281			Ω
R _{B_SRP_DWN}	B-device V _{BUS} SRP Pull Down		656			Ω

USB Transceiver

USB 2.0 certified in full- and low-speed modes.

Notes

18. I_{CC} and I_{CCB} values are the same regardless of USB host or peripheral configuration.

19. There is no appreciable difference in I_{CC} and I_{CCB} values when only two transceivers are powered.

AC Timing Characteristics

Reset Timing

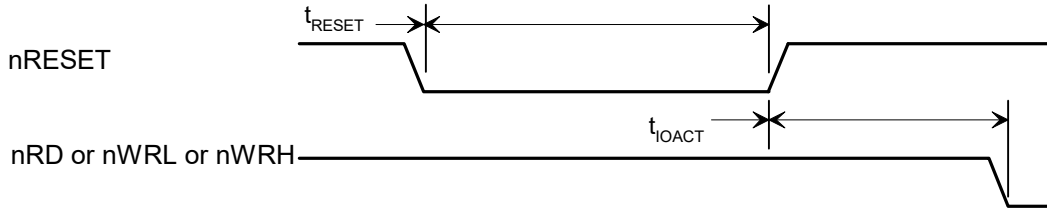

Reset Timing

Table 135. Reset Timing Parameters

Parameter	Description	Min	Typical	Max	Unit
t_{RESET}	nRESET Pulse Width	16			clocks ^[20]
t_{IOACT}	nRESET HIGH to nRD or nWRx active	200			μs

Clock Timing

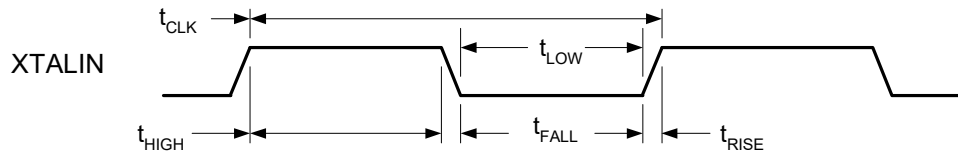

Clock Timing

Table 136. Clock Timing Parameters

Parameter	Description	Min	Typical	Max	Unit
f_{CLK}	Clock Frequency		12.0		MHz
$V_{\text{XINH}}^{[21]}$	Clock Input High (XTALOUT left floating)	1.5	3.0	3.6	V
t_{CLK}	Clock Period	83.17	83.33	83.5	ns
t_{HIGH}	Clock High Time	36		44	ns
t_{LOW}	Clock Low Time	36		44	ns
t_{RISE}	Clock Rise Time			5.0	ns
t_{FALL}	Clock Fall Time			5.0	ns
Duty Cycle		45		55	%

Notes

20. Clock is 12 MHz nominal.

21. V_{XINH} is required to be 3.0 V to obtain an internal 50/50 duty cycle clock.

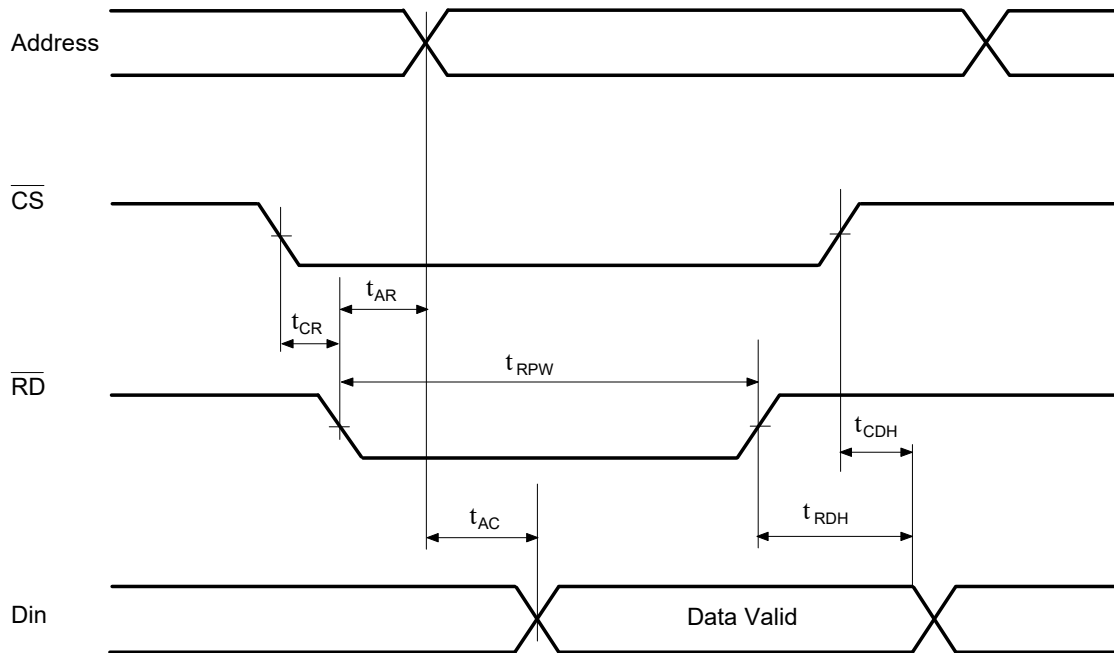
SRAM Read Cycle^[24]

Table 137. SRAM Read Cycle Parameters

Parameter	Description	Min	Typical	Max	Unit
t_{CR}	CS LOW to RD LOW	1			ns
t_{RDH}	RD HIGH to Data Hold	0			ns
t_{CDH}	CS HIGH to Data Hold	0			ns
$t_{RPW}^{[22]}$	RD LOW Time	38		45	ns
t_{AR}	RD LOW to Address Valid			0	ns
$t_{AC}^{[23]}$	RAM Access to Data Valid			12	ns

Notes

22. 0 wait state cycle.

23. t_{AC} External SRAM access time = 12 ns for zero and one wait states. The External SRAM access time = 12 ns + (n - 1)*T for wait states = n, n > 1, T = 48 MHz clock period.

24. Read timing is applicable for nXMEMSEL, nXRAMSEL, and nXROMSEL.

SRAM Write Cycle ^[26]

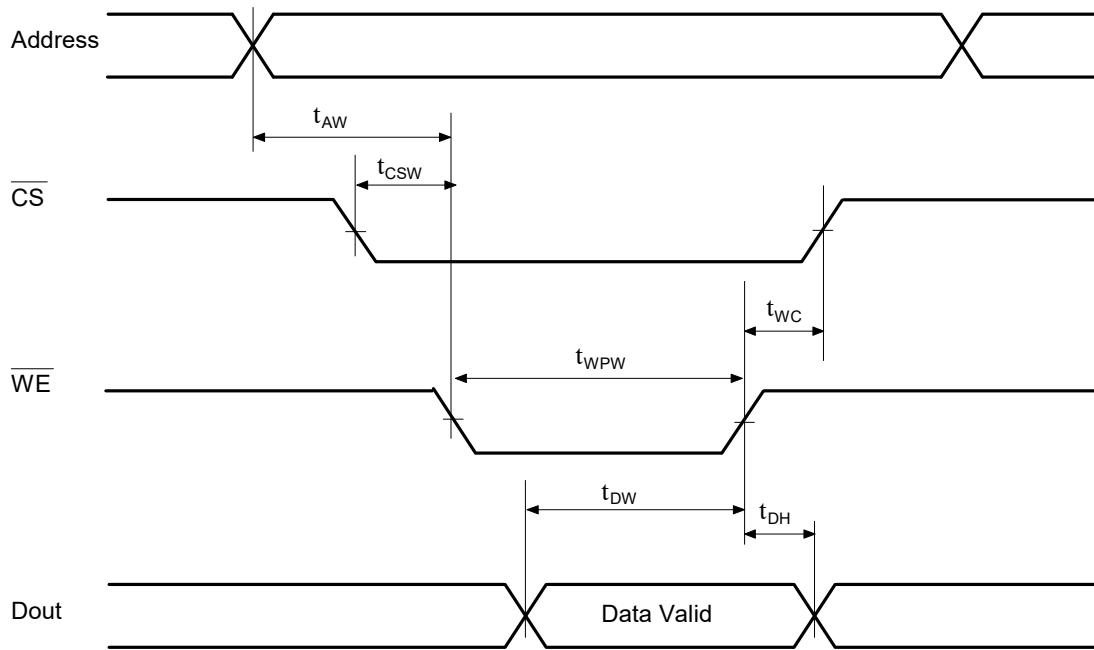

Table 138. SRAM Write Cycle Parameters

Parameter	Description	Min	Typical	Max	Unit
t_{AW}	Write Address Valid to \overline{WE} LOW	7			ns
t_{CSW}	\overline{CS} LOW to \overline{WE} LOW	7			ns
t_{DW}	Data Valid to \overline{WE} HIGH	15			ns
$t_{WPW}^{[25]}$	\overline{WE} Pulse Width	15			ns
t_{DH}	Data Hold from \overline{WE} HIGH	4.5			ns
t_{WC}	\overline{WE} HIGH to \overline{CS} HIGH	13			ns

Notes

25. t_{WPW} The write pulse width = 18.8 ns min. for zero and one wait states. The write pulse = 18.8 ns + (n - 1)*T for wait states = n, n > 1, T = 48 MHz clock period.
 26. Write timing is applicable for nXMEMSEL, nXRAMSEL and nXROMSEL.

I2C EEPROM Timing-Serial IO

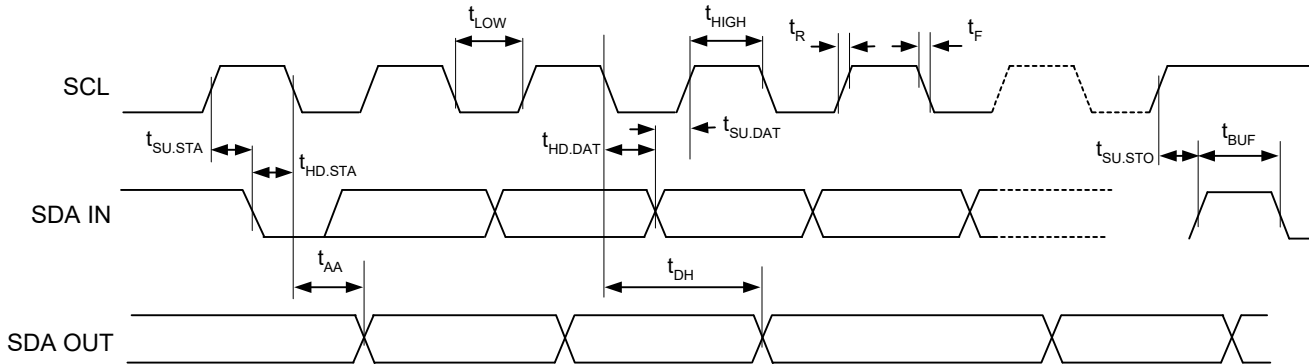

Table 139. I2C EEPROM Timing Parameters

Parameter	Description	Min	Typical	Max	Unit
f_{SCL}	Clock Frequency			400	kHz
t_{LOW}	Clock Pulse Width Low	1300			ns
t_{HIGH}	Clock Pulse Width High	600			ns
t_{AA}	Clock Low to Data Out Valid	900			ns
t_{BUF}	Bus Idle Before New Transmission	1300			ns
$t_{HD.STA}$	Start Hold Time	600			ns
$t_{SU.STA}$	Start Setup Time	600			ns
$t_{HD.DAT}$	Data In Hold Time	0			ns
$t_{SU.DAT}$	Data In Setup Time	100			ns
t_R	Input Rise Time			300	ns
t_F	Input Fall Time			300	ns
$t_{SU.STO}$	Stop Setup Time	600			ns
t_{DH}	Data Out Hold Time	0			ns

HPI (Host Port Interface) Write Cycle Timing

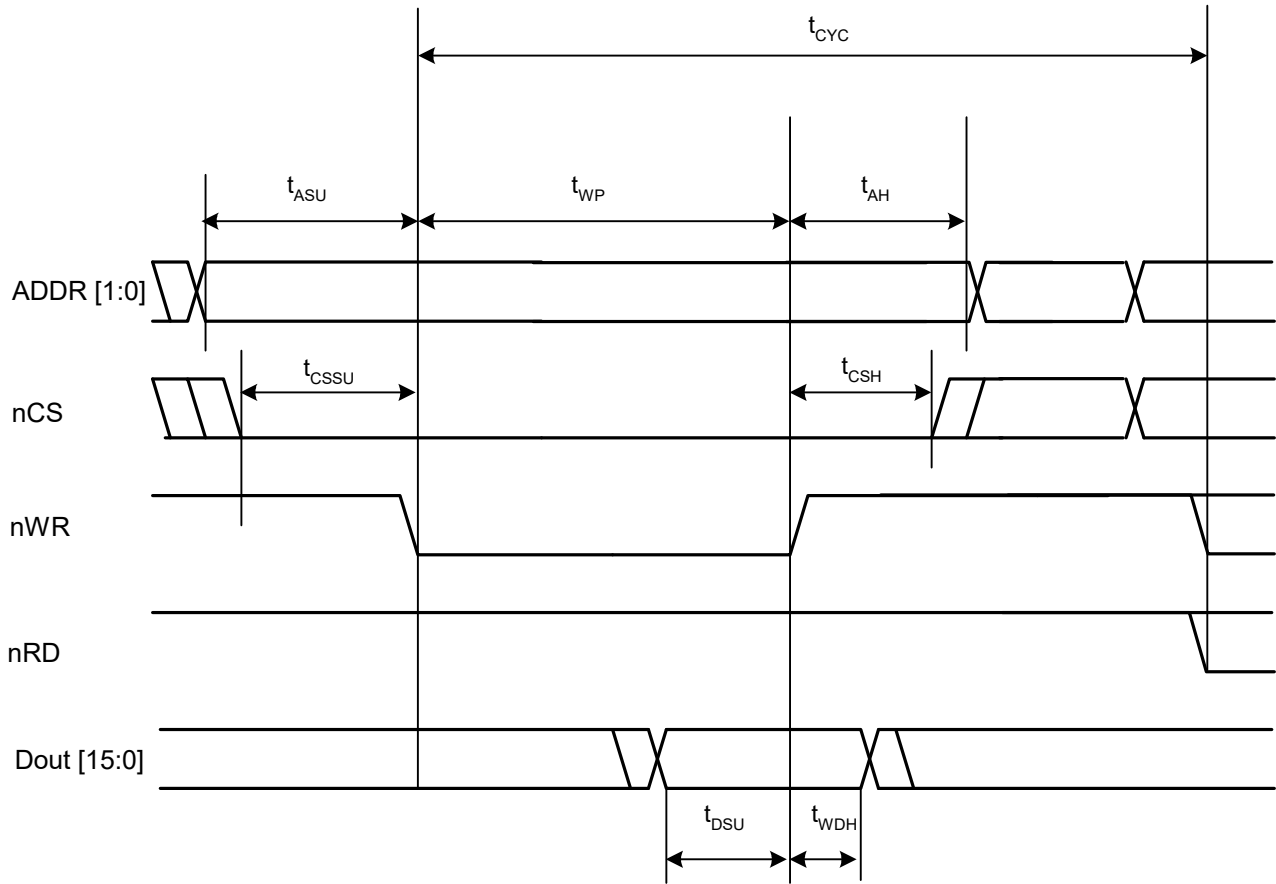

Table 140. HPI Write Cycle Timing Parameters

Parameter	Description	Min	Typical	Max	Unit
t_{ASU}	Address Setup	-1			ns
t_{AH}	Address Hold	-1			ns
t_{CSSU}	Chip Select Setup	-1			ns
t_{CSH}	Chip Select Hold	-1			ns
t_{DSU}	Data Setup	6			ns
t_{WDH}	Write Data Hold	2			ns
t_{WP}	Write Pulse Width	2			$T^{[27]}$
t_{CYC}	Write Cycle Time	6			$T^{[27]}$

Notes

27. T = system clock period = 1/48 MHz.

HPI (Host Port Interface) Read Cycle Timing

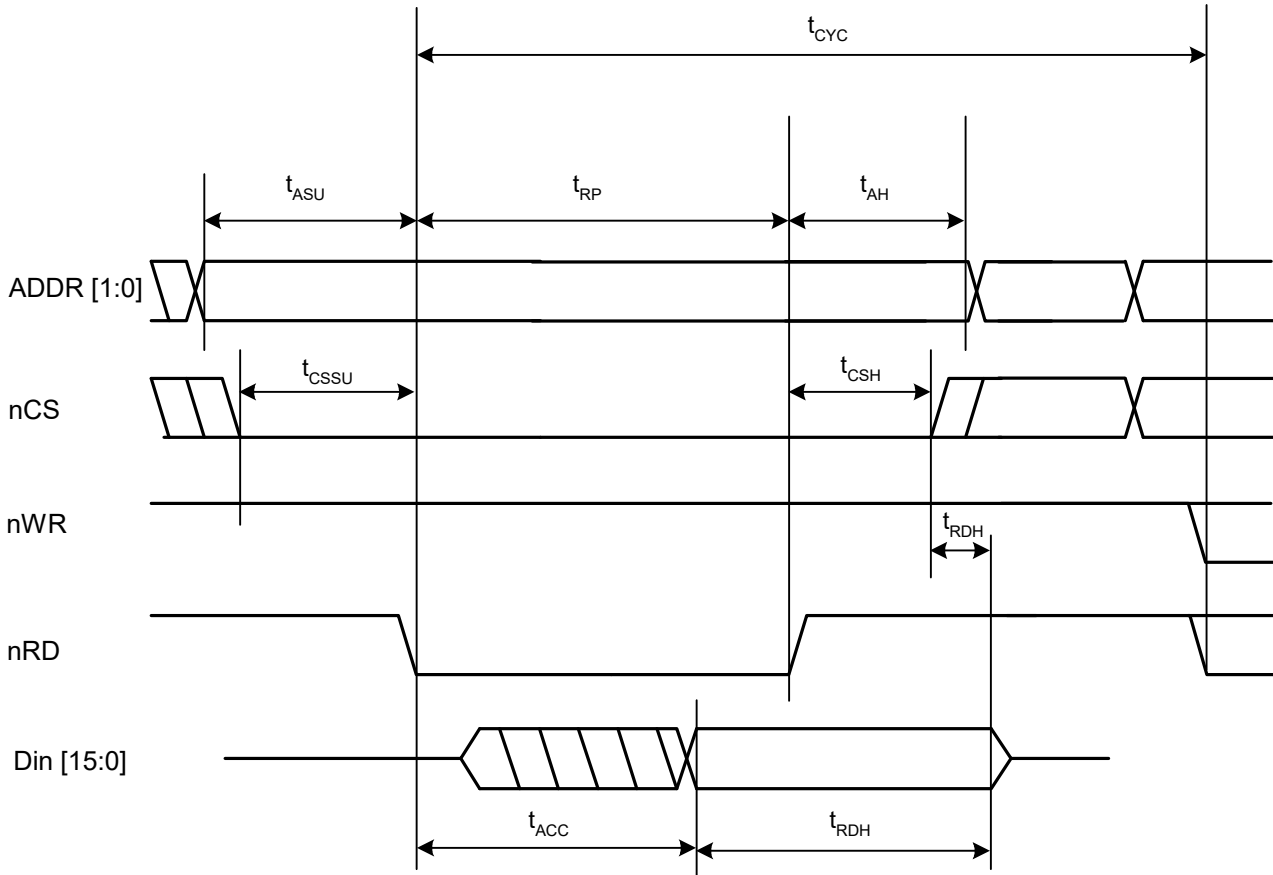

Table 141. HPI Read Cycle Timing Parameters

Parameter	Description	Min	Typical	Max	Unit
t_{ASU}	Address Setup	-1			ns
t_{AH}	Address Hold	-1			ns
t_{CSSU}	Chip Select Setup	-1			ns
t_{CSH}	Chip Select Hold	-1			ns
t_{ACC}	Data Access Time, from HPI_nRD falling			1	$\tau^{[27]}$
t_{RDH}	Read Data Hold, relative to the earlier of HPI_nRD rising or HPI_nCS rising	1.5		7	ns
t_{RP}	Read Pulse Width	2			$\tau^{[27]}$
t_{CYC}	Read Cycle Time	6			$\tau^{[27]}$

IDE Timing

The IDE interface supports PIO mode 0-4 as specified in the Information Technology-AT Attachment-4 with Packet Interface Extension (ATA/ATAPI-4) Specification, T13/1153D Rev 18.

HSS BYTE Mode Transmit

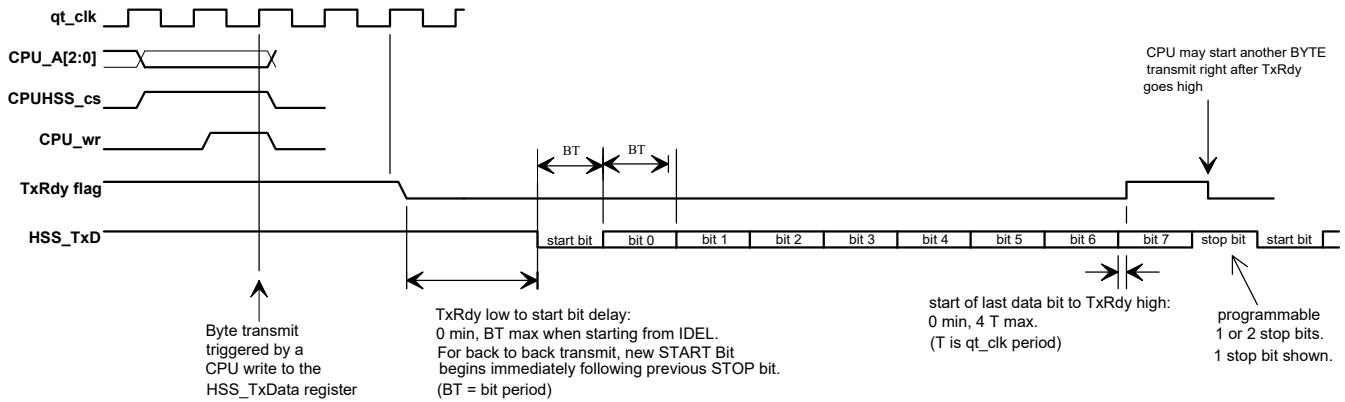

qt_clk, CPU_A, CPUHSS_cs, CPU_wr are internal signals, included in the diagram to illustrate the relationship between CPU operations and HSS port operations.

Bit 0 is LSB of data byte. Data bits are HIGH true: HSS_TxD HIGH = data bit value '1'.

BT = bit time = 1/baud rate.

HSS Block Mode Transmit

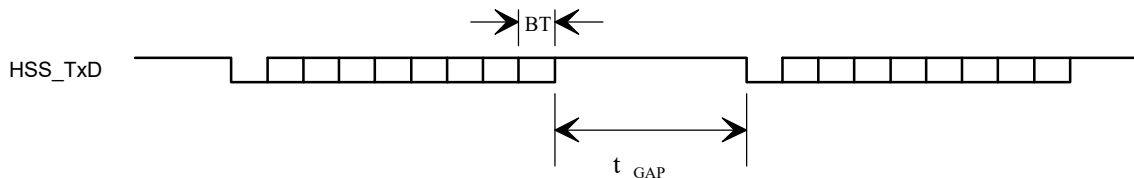

BLOCK mode transmit timing is similar to BYTE mode, except the STOP bit time is controlled by the HSS_GAP value.

The BLOCK mode STOP bit time, $t_{GAP} = (HSS_GAP - 9) BT$, where BT is the bit time, and HSS_GAP is the content of the HSS Transmit Gap register [0xC074].

The default t_{GAP} is 2 BT.

BT = bit time = 1/baud rate.

HSS BYTE and BLOCK Mode Receive

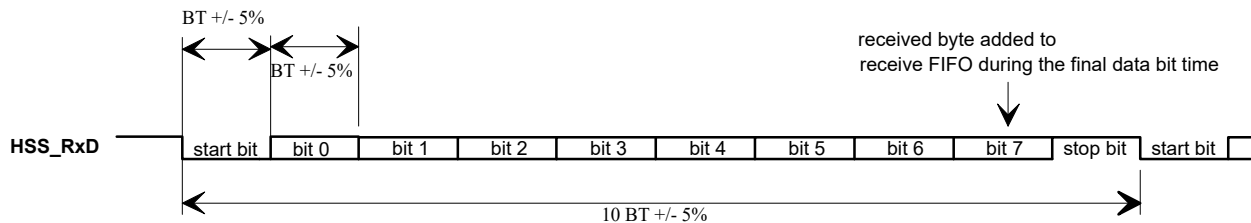

Receive data arrives asynchronously relative to the internal clock. Incoming data bit rate may deviate from the programmed baud rate clock by as much as $\pm 5\%$ (with HSS_RATE value of 23 or higher).

BYTE mode received bytes are buffered in a FIFO. The FIFO not empty condition becomes the RxRdy flag.

BLOCK mode received bytes are written directly to the memory system.

Bit 0 is LSB of data byte. Data bits are HIGH true: HSS_RxD HIGH = data bit value '1'.

BT = bit time = 1/baud rate.

Hardware CTS/RTS Handshake

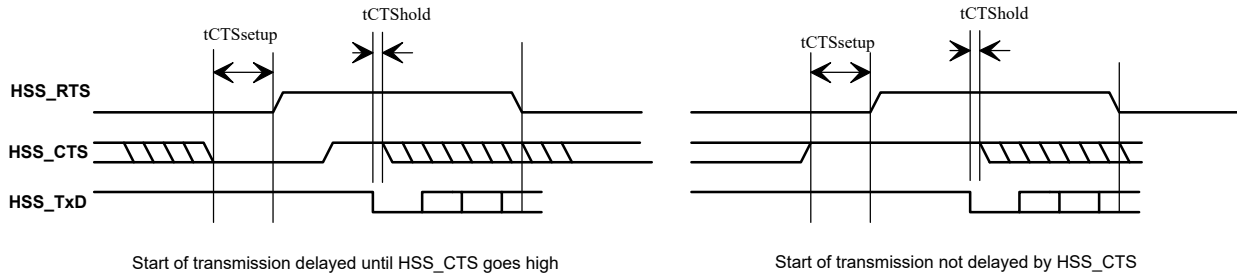

$t_{CTSsetup}$: HSS_CTS setup time before HSS_RTS = 1.5T min.

$t_{CTShold}$: HSS_CTS hold time after START bit = 0 ns min.

T = 1/48 MHz.

When RTS/CTS hardware handshake is enabled, transmission can be help off by deasserting HSS_CTS at least 1.5T before HSS_RTS. Transmission resumes when HSS_CTS returns HIGH. HSS_CTS must remain HIGH until START bit.

HSS_RTS is deasserted in the third data bit time.

An application may choose to hold HSS_CTS until HSS_RTS is deasserted, which always occurs after the START bit.

Register Summary

Table 142. Register Summary

R/W	Address	Register	Bit 15	Bit 14	Bit 13	Bit 12	Bit 11	Bit 10	Bit 9	Bit 8	Default High	
			Bit 7	Bit 6	Bit 5	Bit 4	Bit 3	Bit 2	Bit 1	Bit 0	Default Low	
R	0x0140	HPI Breakpoint	Address...								0000 0000	
			...Address								0000 0000	
R	0x0142	Interrupt Routing	VBUS to HPI Enable	ID to HPI Enable	SOF/EOP2 to HPI Enable	SOF/EOP2 to CPU Enable	SOF/EOP1 to HPI Enable	SOF/EOP1 to CPU Enable	Reset2 to HPI Enable	HPI Swap 1 Enable	0001 0100	
			Resume2 to HPI Enable	Resume1 to HPI Enable	Reserved		Done2 to HPI Enable	Done1 to HPI Enable	Reset1 to HPI Enable	HPI Swap 0 Enable	0000 0000	
W	1: 0x0144 2: 0x0148	SIEXmsg	Data...								xxxx xxxx	
			...Data								xxxx xxxx	
R/W	0x02n0	Device n Endpoint n Control	Reserved							xxxx xxxx		
			IN/OUT Ignore Enable	Sequence Select	Stall Enable	ISO Enable	NAK Interrupt Enable	Direction Select	Enable	ARM Enable	xxxx xxxx	
R/W	0x02n2	Device n Endpoint n Address	Address...								xxxx xxxx	
			...Address								xxxx xxxx	
R/W	0x02n4	Device n Endpoint n Count	Reserved						Count...		xxxx xxxx	
			...Count								xxxx xxxx	
R/W	0x02n6	Device n Endpoint n Status	Reserved				Overflow Flag	Underflow Flag	OUT Exception Flag	IN Exception Flag	xxxx xxxx	
			Stall Flag	NAK Flag	Length Exception Flag	Setup Flag	Sequence Status	Timeout Flag	Error Flag	ACK Flag	xxxx xxxx	
R/W	0x02n8	Device n Endpoint n Count Result	Result...								xxxx xxxx	
			...Result								xxxx xxxx	
R	0xC000	CPU Flags	Reserved...				Global Interrupt Enable	Negative Flag	Overflow Flag	Carry Flag	Zero Flag	0000 0000
			...Reserved									000x xxxx
R/W	0xC002	Bank	Address...						Reserved		0000 0001	
			...Address								000x xxxx	
R	0xC004	Hardware Revision	Revision...								xxxx xxxx	
			...Revision								xxxx xxxx	
R/W	0xC006	GPIO Control	Write Protect Enable	UD	Reserved		SAS Enable	Mode Select		0000 0000		
			HSS Enable	HSS XD Enable	SPI Enable	SPI XD Enable	Interrupt 1 Polarity Select	Interrupt 1 Enable	Interrupt 0 Polarity Select	Interrupt 0 Enable	0000 0000	
R/W	0xC008	CPU Speed	Reserved...						CPU Speed		0000 0000	
			.Reserved								0000 1111	
R/W	0xC00A	Power Control	Host/Device 2B Wake Enable	Host/Device 2A Wake Enable	Host/Device 1B Wake Enable	Host/Device 1A Wake Enable	OTG Wake Enable	Reserved	HSS Wake Enable	SPI Wake Enable	0000 0000	
			HPI Wake Enable	Reserved		GPI Wake Enable	Reserved	Boost 3V OK	Sleep Enable	Halt Enable	0000 0000	

Table 142. Register Summary (Continued)

R/W	Address	Register	Bit 15		Bit 14		Bit 13		Bit 12		Bit 11		Bit 10		Bit 9		Bit 8		Default High	
			Bit 7	Bit 6	Bit 5	Bit 4	Bit 3	Bit 2	Bit 1	Bit 0	Default Low									
R/W	0xC00C	Watchdog Timer	Reserved...																0000 0000	
			...Reserved				Timeout Flag	Period Select			Lock Enable	WDT Enable	Reset Strobe			0000 0000				
R/W	0xC00E	Interrupt Enable	Reserved				OTG Interrupt Enable	SPI Interrupt Enable		Reserved		Host/Device 2 Interrupt Enable	Host/Device 1 Interrupt Enable			0000 0000				
			HSS Interrupt Enable	In Mailbox Interrupt Enable	Out Mailbox Interrupt Enable	Reserved		UART Interrupt Enable	GPIO Interrupt Enable		Timer 1 Interrupt Enable	Timer 0 Interrupt Enable			0001 0000					
R/W	0xC098	OTG Control	Reserved				VBUS Pull-up Enable	Receive Disable	Charge Pump Enable		VBUS Discharge Enable	D+ Pull-up Enable	D- Pull-up Enable			0000 0000				
			D+ Pulldown Enable	D- Pull-down Enable		Reserved				OTG Data Status	ID Status	VBUS Valid Flag			0000 0xxx					
R/W	0: 0xC010 1: 0xC012	Timer n	Count...																1111 1111	
			...Count																1111 1111	
R/W	0xC014	Breakpoint	Address...																0000 0000	
			...Address																0000 0000	
R/W	1: 0xC018 2: 0xC01A	Extended Page n Map	Address...																0000 0000	
			...Address																0000 0000	
R/W	0: 0xC01E 1: 0xC024	GPIO n Output Data	Data...																0000 0000	
			...Data																0000 0000	
R	0: 0xC020 1: 0xC026	GPIO n Input Data	Data...																0000 0000	
			...Data																0000 0000	
R/W	0: 0xC022 1: 0xC028	GPIO n Direction	Direction Select...																0000 0000	
			...Direction Select																0000 0000	
R/W	0xC038	Upper Address Enable	Reserved																xxxx xxxx	
			Reserved								Upper Address Enable	Reserved								xxxx 0xxx
R/W	0xC03A	External Memory Control	Reserved				XRAM Merge Enable	XROM Merge Enable	XMEM Width Select		XMEM Wait Select		Reserved						xxxx xxxx	
			XROM Width Select	XROM Wait Select		Reserved		XRAM Width Select	XRAM Wait Select		Reserved						xxxx xxxx			
R/W	0xC03C	USB Diagnostic	Port 2B Diagnostic Enable	Port 2A Diagnostic Enable	Port 1B Diagnostic Enable	Port 1A Diagnostic Enable		Reserved...								0000 0000				
			...Reserved	Pull-down Enable	LS Pull-up Enable	FS Pull-up Enable	Reserved		Force Select		Reserved						0000 0000			
W	0xC03E	Memory Diagnostic	Reserved										Memory Arbitration Select						0000 0000	
			Reserved																Monitor Enable	0000 0000
R/W	0xC048	IDE Mode	Reserved...																0000 0000	
			...Reserved								Reserved	Mode Select								0000 0000
R/W	0xC04A	IDE Start Address	Address...																0000 0000	
			...Address																0000 0000	
R/W	0xC04C	IDE Stop Address	Address...																0000 0000	
			...Address																0000 0000	
R/W	0xC04E	IDE Control	Reserved...																0000 0000	
			...Reserved								Direction Select	IDE Interrupt Enable	Done Flag	IDE Enable			0000 0000			
-	0xC050-0xC06E	IDE PIO Port																		
R/W	0xC070	HSS Control	HSS Enable	RTS Polarity Select	CTS Polarity Select	XOFF	XOFF Enable	CTS Enable	Receive Interrupt Enable	Done Interrupt Enable		Reserved						0000 0000		
			Transmit Done Interrupt Flag	Receive Done Interrupt Flag	One Stop Bit	Transmit Ready	Packet Mode Select	Receive Overflow Flag	Receive Packet Ready Flag	Receive Ready Flag		Reserved						0000 0000		
R/W	0xC072	HSS Baud Rate	Reserved				HSS Baud...				Reserved						0000 0000			
			...Baud																0001 0111	
R/W	0xC074	HSS Transmit Gap	Reserved																0000 0000	
			Transmit Gap Select																0000 1001	
R/W	0xC076	HSS Data	Reserved																xxxx xxxx	
			Data																xxxx xxxx	
R/W	0xC078	HSS Receive Address	Address...																0000 0000	
			...Address																0000 0000	
R/W	0xC07A	HSS Receive Counter	Reserved										Counter...						0000 0000	
			...Counter																0000 0000	
R/W	0xC07C	HSS Transmit Address	Address..																0000 0000	
			...Address																0000 0000	

Table 142. Register Summary (Continued)

R/W	Address	Register	Bit 15	Bit 14	Bit 13	Bit 12	Bit 11	Bit 10	Bit 9	Bit 8	Default High		
			Bit 7	Bit 6	Bit 5	Bit 4	Bit 3	Bit 2	Bit 1	Bit 0		Default Low	
R/W	0xC07E	HSS Transmit Counter	Reserved						Counter...		0000 0000		
			...Counter									0000 0000	
R/W	0xC080 0xC0A0	Host n Control	Reserved			Preamble Enable		Sequence Select	Sync Enable	ISO Enable	Reserved	Arm Enable	0000 0000
R/W	0xC082 0xC0A2	Host n Address	Address...									0000 0000	
			...Address									0000 0000	
R/W	0xC084 0xC0A4	Host n Count	Reserved	Port Select	Reserved			Count...				0000 0000	
			...Count									0000 0000	
R/W	0xC084 0xC0A4	Device n Port Select	Reserved	Port Select	Reserved...							0000 0000	
			...Reserved									0000 0000	
R	0xC086 0xC0A6	Host n PID	Reserved				Overflow Flag	Underflow Flag	Reserved			0000 0000	
			Stall Flag	NAK Flag	Length Exception Flag	Reserved	Sequence Status	Timeout Flag	Error Flag	ACK Flag	0000 0000		
W	0xC086 0xC0A4	Host n EP Status	Reserved						PID Select		Endpoint Select	0000 0000	
R	0xC088 0xC0A8	Host n Count Result	Result...									0000 0000	
			...Result									0000 0000	
W	0xC088 0xC0A8	Host n Device Address	Reserved...									0000 0000	
			...Reserved	Address								0000 0000	
R/W	0xC08A 0xC0AA	USB n Control	Port B D+ Status	Port B D- Status	Port A D+ Status	Port A D- Status	LOB	LOA	Mode Select	Port B Resistors Enable	xxxx 0000		
			Port A Resistors Enable	Port B Force D+/- State	Port A Force D± State		Suspend Enable	Port B SOF/EOP Enable	Port A SOF/EOP Enable	0000 0000			
R/W	0xC08C	Host 1 Interrupt Enable	VBUS Interrupt Enable	ID Interrupt Enable	Reserved			SOF/EOP Interrupt Enable	Reserved	0000 0000			
			Port B Wake Interrupt Enable	Port A Wake Interrupt Enable	Port B Connect Change Interrupt Enable	Port A Connect Change Interrupt Enable	Reserved		Done Interrupt Enable	0000 0000			
R/W	0xC08C	Device 1 Interrupt Enable	VBUS Interrupt Enable	ID Interrupt Enable	Reserved		SOF/EOP Timeout Interrupt Enable	Reserved	SOF/EOP Interrupt Enable	Reset Interrupt Enable	0000 0000		
			EP7 Interrupt Enable	EP6 Interrupt Enable	EP5 Interrupt Enable	EP4 Interrupt Enable	EP3 Interrupt Enable	EP2 Interrupt Enable	EP1 Interrupt Enable	EP0 Interrupt Enable	0000 0000		
R/W	0xC08E 0xC0AE	Device n Address	Reserved...									0000 0000	
			...Reserved	Address								0000 0000	
R/W	0xC090	Host 1 Status	VBUS Interrupt Flag	ID Interrupt Flag	Reserved			SOF/EOP Interrupt Flag	Reserved	xxxx xxxx			
			Port B Wake Interrupt Flag	Port A Wake Interrupt Flag	Port B Connect Change Interrupt Flag	Port A Connect Change Interrupt Flag	Port B SE0 Status	Port A SE0 Status	Reserved	Done Interrupt Flag	xxxx xxxx		
R/W	0xC090	Device 1 Status	VBUS Interrupt Flag	ID Interrupt Flag	Reserved			SOF/EOP Interrupt Flag	Reset Interrupt Flag	xxxx xxxx			
			EP7 Interrupt Flag	EP6 Interrupt Flag	EP5 Interrupt Flag	EP4 Interrupt Flag	EP3 Interrupt Flag	EP2 Interrupt Flag	EP1 Interrupt Flag	EP0 Interrupt Flag	xxxx xxxx		
R/W	0xC092 0xC0B2	Host n SOF/EOP Count	Reserved		Count...							0010 1110	
			...Count									1110 0000	
R	0xC092 0xC0B2	Device n Frame Number	SOF/EOP Timeout Flag	SOF/EOP Timeout Interrupt Count			Reserved	Frame...				0000 0000	
			...Frame									0000 0000	
R	0xC094 0xC0B4	Host n SOF/EOP Counter	Reserved		Counter...							xxxx xxxx	
			...Counter									xxxx xxxx	
W	0xC094 0xC0B4	Device n SOF/EOP Count	Reserved		Count...							0010 1110	
			...Count									1110 0000	
R	0xC096 0xC0B6	Host n Frame	Reserved						Frame...				0000 0000
			...Frame									0000 0000	
R/W	0xC0AC	Host 2 Interrupt Enable	Reserved						SOF/EOP Interrupt Enable	Reserved	0000 0000		
			Port B Wake Interrupt Enable	Port A Wake Interrupt Enable	Port B Connect Change Interrupt Enable	Port A Connect Change Interrupt Enable	Reserved		Done Interrupt Enable	0000 0000			

Table 142. Register Summary (Continued)

R/W	Address	Register	Bit 15		Bit 14		Bit 13		Bit 12		Bit 11		Bit 10		Bit 9		Bit 8		Default High							
			Bit 7		Bit 6		Bit 5		Bit 4		Bit 3		Bit 2		Bit 1		Bit 0		Default Low							
R/W	0xC0AC	Device 2 Interrupt Enable	Reserved						SOF/EOP Timeout Interrupt Enable		Wake Interrupt Enable		SOF/EOP Interrupt Enable		Reset Interrupt Enable		0000 0000		0000 0000							
			EP7 Interrupt Enable		EP6 Interrupt Enable		EP5 Interrupt Enable		EP4 Interrupt Enable		EP3 Interrupt Enable		EP2 Interrupt Enable		EP1 Interrupt Enable		EP0 Interrupt Enable		0000 0000							
R/W	0xC0B0	Host 2 Status	Reserved						SOF/EOP Interrupt Flag		Reserved		Reserved		Reserved		xxxx xxxx		xxxx xxxx							
			Port B Wake Interrupt Flag		Port A Wake Interrupt Flag		Port B Connect Change Interrupt Flag		Port A Connect Change Interrupt Flag		Port B SE0 Status		Port A SE0 Status		Reserved		Done Interrupt Flag		xxxx xxxx							
R/W	0xC0B0	Device 2 Status	Reserved						SOF/EOP Timeout Interrupt Enable		Wake Interrupt Flag		SOF/EOP Interrupt Flag		Reset Interrupt Flag		xxxx xxxx		xxxx xxxx							
			EP7 Interrupt Flag		EP6 Interrupt Flag		EP5 Interrupt Flag		EP4 Interrupt Flag		EP3 Interrupt Flag		EP2 Interrupt Flag		EP1 Interrupt Flag		EP0 Interrupt Flag		xxxx xxxx							
R/W	0xC0C6	HPI Mailbox	Message...																0000 0000							
			...Message																0000 0000							
R/W	0xC0C8	SPI Configuration	3Wire Enable		Phase Select		SCK Polarity Select		Scale Select				Reserved		1000 0000											
			Master Active Enable		Master Enable		SS Enable		SS Delay Select				0001 1111													
R/W	0xC0CA	SPI Control	SCK Strobe		FIFO Init		Byte Mode		FullDuplex		SS Manual		Read Enable		Transmit Ready		receive Data Ready		0000 0001							
			Transmit Empty		Receive Full		Transmit Bit Length				Receive Bit Length				1000 0000											
R/W	0xC0CC	SPI Interrupt Enable	Reserved...																0000 0000							
			...Reserved																Receive Interrupt Enable		Transmit Interrupt Enable		Transfer Interrupt Enable		0000 0000	
R	0xC0CE	SPI Status	Reserved...																0000 0000							
			FIFO Error Flag		Reserved				Receive Interrupt Flag		Transmit Interrupt Flag		Transfer Interrupt Flag		0000 0000											
W	0xC0D0	SPI Interrupt Clear	Reserved...																0000 0000							
			...Reserved																Transmit Interrupt Clear		Transmit Interrupt Clear		0000 0000			
R/W	0xC0D2	SPI CRC Control	CRC Mode				CRC Enable		CRC Clear		Receive CRC		One in CRC		Zero in CRC		Reserved...		0000 0000							
			...Reserved																0000 0000							
R/W	0xC0D4	SPI CRC Value	CRC																1111 1111							
			...CRC																1111 1111							
R/W	0xC0D6	SPI Data Port t	Reserved																xxxx xxxx							
			Data																xxxx xxxx							
R/W	0xC0D8	SPI Transmit Address	Address...																0000 0000							
			...Address																0000 0000							
R/W	0xC0DA	SPI Transmit Count	Reserved																Count...		0000 0000					
			...Count																0000 0000							
R/W	0xC0DC	SPI Receive Address	Address...																0000 0000							
			...Address																0000 0000							
R/W	0xC0DE	SPI Receive Count	Reserved																Count...		0000 0000					
			...Count																0000 0000							
R/W	0xC0E0	UART Control	Reserved...																0000 0000							
			...Reserved						Scale Select		Baud Select				UART Enable		0000 0111									
R	0xC0E2	UART Status	Reserved...																0000 0000							
			...Reserved																Receive Full		Transmit Full		0000 0000			
R/W	0xC0E4	UART Data	Reserved																0000 0000							
			Data																0000 0000							
R/W	0xC0E6	PWM Control	PWM Enable		Reserved				Prescale Select				Mode Select		0000 0000											
			PWM3 Polarity Select		PWM2 Polarity Select		PWM1 Polarity Select		PWM0 Polarity Select		PWM3 Enable		PWM2 Enable		PWM1 Enable		PWM0 Enable		0000 0000							
R/W	0xC0E8	PWM Maximum Count	Reserved																Count...		0000 0000					
			...Count																0000 0000							
R/W	0: 0xC0EA 1: 0xC0EE 2: 0xC0F2 3: 0xC0F6	PWM n Start	Reserved																Address...		0000 0000					
			...Address																0000 0000							

Table 142. Register Summary (Continued)

R/W	Address	Register	Bit 15	Bit 14	Bit 13	Bit 12	Bit 11	Bit 10	Bit 9	Bit 8	Default High	
			Bit 7	Bit 6	Bit 5	Bit 4	Bit 3	Bit 2	Bit 1	Bit 0	Default Low	
R/W	0: 0xC0EC 1: 0xC0F0 2: 0xC0F4 3: 0xC0F8	PWM n Stop	Reserved							Address...		0000 0000
			...Address									0000 0000
R/W	0xC0FA	PWM Cycle Count	Count...								0000 0000	
			...Count								0000 0000	
R		HPI Status Port	VBUS Flag	ID Flag	Reserved	SOF/EOP2 Flag	Reserved	SOF/EOP1 Flag	Reset2 Flag	Mailbox In Flag		
			Resume2 Flag	Resume1 Flag	SIE2msg	SIE1msg	Done2 Flag	Done1 Flag	Reset1 Flag	Mailbox Out Flag		

Ordering Information

Table 143. Ordering Information

Ordering Code	Package Type	AEC	Pb-Free	Temperature Range
CY7C67300-100AXI	100-pin TQFP		X	-40 to 85°C
CY7C67300-100AXA	100-pin TQFP	X	X	-40 to 85°C
CY7C67300-100AXIT	100-pin TQFP, tape and reel		X	-40 to 85°C
CY7C67300-100AXAT	100-pin TQFP, tape and reel	X	X	-40 to 85°C

Ordering Code Definitions

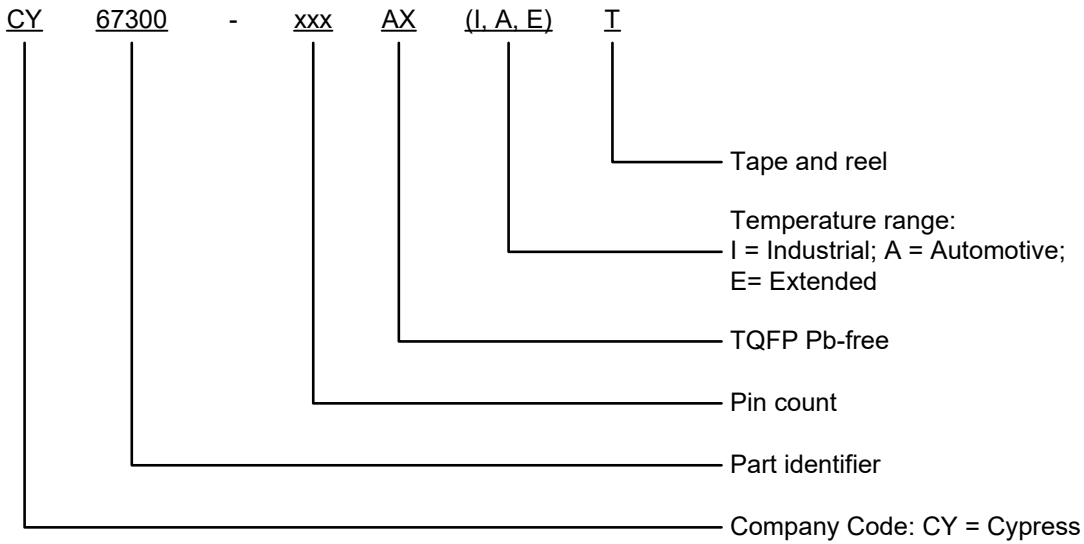

Package Diagram

Figure 12. 100-pin TQFP (14 × 14 × 1.4 mm) A100SA

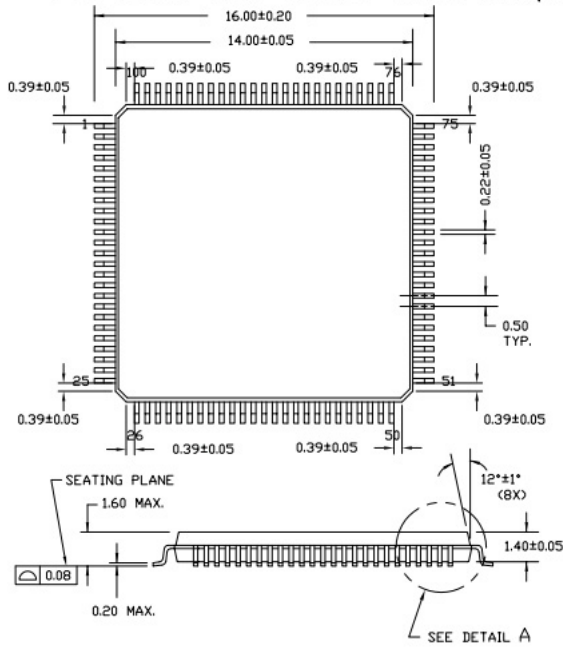

- NOTE:
1. JEDEC STD REF MS-026
 2. BODY LENGTH DIMENSION DOES NOT INCLUDE MOLD PROTRUSION/END FLASH
MOLD PROTRUSION/END FLASH SHALL NOT EXCEED 0.0098 in (0.25 mm) PER SIDE
BODY LENGTH DIMENSIONS ARE MAX PLASTIC BODY SIZE INCLUDING MOLD MISMATCH
 3. DIMENSIONS IN MILLIMETERS

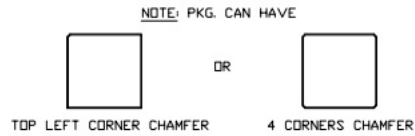
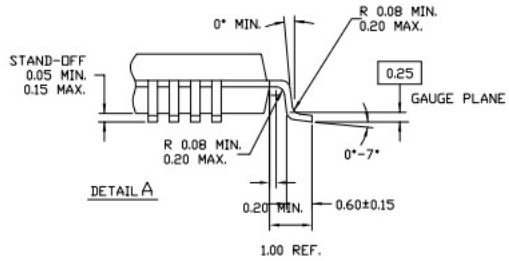

51-85048 *J

Acronyms

Table 144. Acronyms Used in this Document

Acronym	Description
AC	alternating current
AEC	Automotive Electronics Council
CPU	central processing unit
CRC	cyclic redundancy check
DC	direct current
DMA	direct memory access
EEPROM	electronically erasable programmable read only memory
EOP	end of packet
XRAM	external ram memory
FIFO	first in first out
GPIO	general purpose input/output
HSS	high speed serial
HPI	host port interface
IDE	integrated device electronics
I ² C	inter-integrated circuit
KVM	keyboard-video-mouse
OTG	on-the-go protocol
PLL	phase locked loop
POR	power-on reset
PIO	programmed input/output
PWM	pulse width modulation
RAM	random access memory
ROM	read only memory
SPI	serial peripheral interface
SIE	serial-interface-engine
SE0	single ended zero
SOF	start of frame
SRAM	static random access memory
TQFP	thin quad flat pack
TTL	transistor-transistor logic
UART	universal asynchronous receiver/transmitter
USB	universal serial bus
WDT	watchdog timer

Document Conventions

Units of Measure

Table 145. Units of Measure

Symbol	Unit of Measure
ns	nanosecond
V	volt
mV	millivolt
μW	microwatt
μA	microampere
mA	milliampere
μs	microsecond
ms	millisecond
MHz	megahertz
μF	microfarad
pF	picofarad
mW	milliwatt
W	watt
ppm	parts per million
°C	degree Celsius

Errata

This document describes the errata for the EZ-Host™ Programmable Embedded USB Host/Peripheral Controller, CY7C67300 Product Family. Details include errata trigger conditions, available workaround, and silicon revision applicability. Compare this document to the device's datasheet for a complete functional description.

Contact your local Cypress Sales Representative if you have questions.

Part Numbers Affected

Part Number	Device Characteristics
CY7C67300	All Packages

CY7C67300 Qualification Status

Product status: In Production

CY7C67300 Errata Summary

The following table defines the errata applicability to available CY7C67300 family devices. An 'X' indicates that the errata pertains to the selected device.

Note Click on the errata table items to view their descriptions.

Items	CY7C67300	Silicon Revision	Fix Status
1. HPI write to SIE registers	X	A	No silicon revision planned, use workaround.
2. Hub and low-speed device attached to a root hub of the EZ-Host chip	X	A	No silicon revision planned, use workaround.
3. IDE register read when GPIO24 pin is low	X	A	No silicon revision planned, use workaround.
4. UART Does Not Recognize Framing Errors	X	A	No silicon revision planned, use workaround.
5. UART does not override GPIO Control Register	X	A	No silicon revision planned, use workaround.
6. VBUS Interrupt (VBUS Valid) Requires Debouncing	X	A	No silicon revision planned, use workaround.
7. Coupled SIE Interrupt Enable Bits	X	A	No silicon revision planned, use workaround.
8. Un-Initialized SIExmsg Registers	X	A	No silicon revision planned, use workaround.
9. BIOS USB Peripheral Mode: Descriptor Length	X	A	No silicon revision planned, use workaround.
10. Peripheral short packet issue	X	A	No silicon revision planned, use workaround.
11. Data toggle corruption issue	X	A	No silicon revision planned, use workaround.
12. Code fails to load from EEPROM	X	A	No silicon revision planned, use workaround.
13. ISOCH Endpoint Descriptor error	X	A	No silicon revision planned, use workaround.
14. Missing Endpoint Interrupts in USB Peripheral Mode	X	A	No silicon revision planned, use workaround.

1. HPI write to SIE registers

■ Problem Definition

Writing to the SIE2 Control register via HPI can corrupt the SIE1 Control register.

Writing to the SIE1 Control register via HPI can corrupt the SIE2 Control register.

■ Parameters Affected

SIE Control registers.

■ Trigger Condition(S)

When an external processor accesses the SIE1 or SIE2 register at the same time the internal CY16 CPU is also accessing the opposite SIE, the SIE accessed by the CY16 CPU will be corrupted. For example, the external processor writes a value of 0x80 to the SIE2 register 0xC0B0 while the internal CY16 is doing a read/write to the SIE1 register 0xC08C, the SIE1 register 0xC08C, will be corrupted with the value 0x80.

■ Scope of Impact

If the internal CPU and the external CPU access the SIEs at the same time, contention will occur resulting in incorrect data in one of the SIE registers.

■ Workaround

1. Use the LCP COMM_WRITE_CTRL_REG to handle the writing to SIE registers.
2. Use download code to handle SIE WRITE commands.
3. Avoid accessing SIE register from the external CPU. For example, route all the SIE interrupts to the software mailbox interrupt registers 0x144 and 0x148. This requires user to create download code.

■ Fix Status

No silicon revision planned, use workaround. An implementation example is included in the Cypress Windows CE driver.

2. Hub and low-speed device attached to a root hub of the EZ-Host chip

■ Problem Definition

When a hub and a low-speed device are connected to the same SIE, the hub does not pass the USB packets from the downstream to the upstream.

■ Parameters Affected

SOF timing.

■ Trigger Condition(S)

Connecting a hub and a low-speed device to the same root hub (SIE) of the EZ-Host chip.

■ Scope of Impact

The EZ-Host does not generate an accurate 1 ms SOF time frame to the hub.

■ Workaround

1. Code can detect the condition and report a message to the user.
2. The low-speed device could be attached to one of the hub downstream ports.

■ Fix Status

No silicon revision planned, use workaround.

3. IDE register read when GPIO24 pin is low

■ Problem Definition

The part does not service USB ISRs when the GPIO24 pin (also labeled as HPI_INT and IORDY) is low and any IDE register is read.

■ Parameters Affected

USB ISRs do not get serviced.

■ Trigger Condition(S)

The IDE registers (0xC050 through 0xC06E) should not be read unless IDE is being used. Debuggers that read all memory locations while single stepping can cause this situation to manifest itself.

■ Scope of Impact

If you are debugging and using this pin, your application will appear to hang.

■ Workaround

When running in standalone mode, avoid using the GPIO24 pin if possible.

■ Fix Status

No silicon revision planned, use workaround.

4. UART Does Not Recognize Framing Errors

■ Problem Definition

The UART is not designed to recognize framing errors.

■ Parameters Affected

UART serial communications.

■ Trigger Condition(S)

Some platforms can cause EZ-Host to see a string of NULL characters and cause the UART to get out of sync.

■ Scope of Impact

This can cause the UART to lose connection with the host during serial communications. One example of this is if the UART is used as the debug port to the PC. This problem has occurred on, but is not limited to, Dell™ machines running Windows® XP or Windows® 2000.

■ Workaround

For general use, there is no workaround. If this problem is experienced while debugging, try running the debugger on a different host (PC/OS). Otherwise the USB port can be used for the debugging interface.

■ Fix Status

No silicon revision planned, use workaround.

5. UART does not override GPIO Control Register

■ Problem Definition

When the UART is enabled, the GPIO Control Register still has control over GPIO 27 (UART RX pin). When enabled, the UART should override the GPIO Control Register, which defaults to setting the pin as an input.

■ Parameters Affected

UART serial communications.

■ Trigger Condition(S)

Enabling UART.

■ Scope of Impact

GPIO 27 UART RX pin is controlled by GPIO Control Register and defaults to an input. The UART mode does not override the GPIO Control Register for this pin and can be inadvertently configured as an output.

■ Workaround

Ensure the GPIO Control Register is written appropriately to set GPIO27 as an input when the UART is enabled.

■ Fix Status

No silicon revision planned, use workaround.

6. VBUS Interrupt (VBUS Valid) Requires Debouncing

■ Problem Definition

The VBUS interrupt in the Host/Device Status Registers [0xC090 and 0xC0B0] and OTG Control Register [0xC098] triggers multiple times whenever VBUS is turned on. It should only trigger once when VBUS rises above 4.4V and once when VBUS falls from above 4.4V to 0V.

■ Parameters Affected

Electrical.

■ Trigger Condition(S)

VBUS turned on.

■ Scope of Impact

Host/Device Registers and OTG Control Register trigger multiple times.

■ Workaround

When reading the status of this interrupt, a software debounce should be implemented.

■ Fix Status

No silicon revision planned, use workaround. Examples are provided in the Development Kit Software.

7. Coupled SIE Interrupt Enable Bits

■ Problem Definition

Host/Device 1 SIE events will still trigger an interrupt when only the Host/Device 2 SIE Interrupt Enable is set and vice versa.

■ Parameters Affected

Host/Device SIE Interrupts.

■ Trigger Condition(S)

Setting only 1 Host/Device SIE Interrupt Enable.

■ Scope of Impact

The Host/Device global Interrupt Enable bits cannot be used to disable each Host/Device SIE independently. These bits are found in the Interrupt Enable Register (0xC00E).

■ Workaround

If an SIE Interrupt is desired, both Host/Device 1 and Host/Device 2 Interrupt Enable bits should be set in the Global Interrupt Enable Register (0xC00E). To properly mask an SIE Interrupt to a single SIE, the lower level Host/Device Interrupt Enable Registers (0xC08C and 0xC0AC) must be used. For example, setting the Host/Device 2 IE Register to 0x0000 will prevent any Host/Device 2 events from generating a Host/Device Interrupt. To disable all SIE interrupts, both Host/Device Interrupt Enable bits in the Interrupt Enable Register should be cleared.

■ Fix Status

No silicon revision planned, use workaround.

8. Un-Initialized SIExmsg Registers

■ Problem Definition

The SIE1msg and SIE2msg Registers [0x0144 and 0x0148] are not initialized at power up.

■ Parameters Affected

HPI interrupts.

■ Trigger Condition(S)

Power up initialization.

■ Scope of Impact

If you are using the HPI interface in co-processor mode, random data will be written to the SIE1msg and SIE2msg Registers [0x0144 and 0x0148] at power up. This will cause two improper HPI interrupts (HPI_INTR) to occur, one for each of the two SIExmsg Registers.

■ Workaround

The external processor should clear the SIExmsg Registers [0x0144 and 0x0148] shortly after nRESET is de-asserted and prior to the expected processing of proper HPI interrupts (generally 10 ms after nRESET is de-asserted).

■ Fix Status

No silicon revision planned, use workaround.

9. BIOS USB Peripheral Mode: Descriptor Length

■ Problem Definition

The BIOS will not properly return a descriptor or set of descriptors, if the length is a multiple of the control endpoint's maximum packet size.

■ Parameters Affected

Control Endpoint maximum packet size.

■ Trigger Condition(S)

Get Descriptor requests.

■ Scope of Impact

If the descriptor length is a multiple of the maximum packet size, the BIOS will respond with a STALL instead of a zero-length data packet for the final IN request.

■ Workaround

If the requested descriptor length is a multiple of the maximum packet size, then either the maximum packet size or the descriptor length needs to change. A descriptor length can be increased by simply adding a padded byte to the end of a descriptor and increasing the descriptor Length byte by one. Section 9.5 (Descriptor) of the USB 2.0 specification allows a descriptor length to be larger than the value defined in the specification.

■ Fix Status

No silicon revision planned, use workaround.

10. Peripheral short packet issue

■ Problem Definition

When an SIE is configured as a peripheral, the SUSBx_RECEIVE function does not invoke the callback function when it receives a short packet.

■ Parameters Affected

SIEx Endpoint x Interrupt (Interrupt 32-47).

■ Trigger Condition(S)

This issue is seen when an SIE is configured as a peripheral during an OUT data transfer when the host sends a zero length or short packet. If this occurs, the BIOS will behave as if a full packet was received and will continue to accept data until the Device n Endpoint n Count Register value is satisfied.

■ Scope of Impact

All peripheral functions are susceptible to this, as it is a normal occurrence with USB traffic.

■ Workaround

To fix this problem, the SIEx Endpoint x Interrupt must be replaced for any peripheral endpoint that is configured as an OUT endpoint.

1. Acquire the file called *susb1.s* from Cypress Support or download a newer version of the frameworks that has this fix applied and includes *susb1.s*.
2. Modify *fwxcfg.h* in your project to have the following flags and define/undef the fix for the endpoints you are using:

```
#define FIX_USB1_EP1
#define FIX_USB1_EP2
#undef  FIX_USB1_EP3
#undef  FIX_USB1_EP4
#undef  FIX_USB1_EP5
#undef  FIX_USB1_EP6
#undef  FIX_USB1_EP7

#undef  FIX_USB2_EP1
#undef  FIX_USB2_EP2
#undef  FIX_USB2_EP3
#undef  FIX_USB2_EP4
#undef  FIX_USB2_EP5
#undef  FIX_USB2_EP6
#undef  FIX_USB2_EP7
```

3. Add the new *susb1.s* to the included assembly source files in the make file.
For example : `ASM_SRC := startup.s isrs.s susb1.s`
4. Add `usb_init` somewhere in the startup code. This will likely be in *fwxmain.c* as demonstrated below:

```
void fwx_program_init(void)
{
    void usb_init(); /* define the prototype */
    usb_init();
    fwx_init(); /* Initialize everything in the base framework. */
}
```

5. Build the project using the modified make file.

■ Fix Status

No silicon revision planned, use workaround.

11.Data toggle corruption issue

■ Problem Definition

When an SIE is configured as a peripheral, data toggle corruption as specified in the USB 2.0 specification, section 8.6.4, does not work as specified.

■ Parameters Affected

SIEx Endpoint x Interrupt (Interrupt 32-47).

■ Trigger Condition(S)

This issue is seen when an SIE is configured as a peripheral and the host sends an incorrect data toggle. According to the USB specification, when an incorrect data toggle is seen from the host, the peripheral should throw away the data but increment the data toggle bit to re-synchronize the data toggle bits. In the current ROM BIOS, the SIEx Endpoint x Interrupt will ignore the data toggle error and accept the data.

■ Scope of Impact

All peripheral functions are susceptible to this as it is a normal occurrence with USB traffic.

■ Workaround

To fix this problem, the SIEx Endpoint x Interrupt must be replaced for any endpoint that is configured as an OUT endpoint.

1. Acquire the file called *susb1.s* from Cypress Support or download a newer version of the frameworks that has this included.
2. Modify *fwxcfg.h* in your project to have the following flags and define/undef the fix for the endpoints you are using:

```
#define FIX_USB1_EP1
#define FIX_USB1_EP2
#undef  FIX_USB1_EP3
#undef  FIX_USB1_EP4
#undef  FIX_USB1_EP5
#undef  FIX_USB1_EP6
#undef  FIX_USB1_EP7
```

```
#undef FIX_USB2_EP1
#undef FIX_USB2_EP2
#undef FIX_USB2_EP3
#undef FIX_USB2_EP4
#undef FIX_USB2_EP5
#undef FIX_USB2_EP6
#undef FIX_USB2_EP7
```

3. Add the new *susb1.s* to the included assembly source files in the make file.
For example :ASM_SRC := startup.s isrs.s susb1.s
4. Add *usb_init* somewhere in the startup code. This will likely be in *fwxmain.c* as demonstrated below:

```
void fwx_program_init(void)
{
void usb_init(); /* define the prototype */

usb_init();

fwx_init(); /* Initialize everything in the base framework. */
}
```

5. Build the project using the modified make file.

■ Fix Status

No silicon revision planned, use workaround.

12.Code fails to load from EEPROM

■ Problem Definition

If, while the BIOS is loading firmware, the part is reset and at that time the EEPROM is driving the SDA line low, the BIOS will configure the part for co-processor mode instead of standalone mode.

■ Parameters Affected

Initialization.

■ Trigger Condition(S)

Reset the part while firmware is being loaded from the EEPROM.

■ Scope of Impact

The firmware download process will not finish, leaving the part configured in co-processor mode.

■ Workaround

There is no workaround. Cycle power to the EEPROM to download firmware.

■ Fix Status

No silicon revision planned, use workaround.

13.ISOCH Endpoint Descriptor error

■ Problem Definition

Setting any bit other than 1:0 in the bmAttributes field will cause the ISOCH Endpoint Descriptors to be reported incorrectly.

■ Parameters Affected

Isochronous transfers.

■ Trigger Condition(S)

Setting any bit other than 1:0 in the bmAttributes field.

■ Scope of Impact

If the bmAttributes field in the Endpoint Descriptor is using bits 5...2, the BIOS will not correctly parse the endpoint and set up the part correctly for ISO transfers.

■ Workaround

There are two methods that can be used.

A.Mask these bits before the BIOS parses the descriptors using the SET_INTERFACE handler. An example of this is given in the "Using Multiple Interfaces to Implement a USB Isochronous Composite Peripheral with EZ-Host™ and EZ-OTG™."

B.Replace the BIOS delta config interrupt and modify the USB-parse code to mask off all but the lower two bits of the bmAttribute. A possible solution might look like this.

```
@@test b[r8+bEPAttribute], 0x01 ; check ISO
rz
test b[r8+bEPAttribute], 0x02
rnz
;if we get here, then the lower two bits
;of bEPAttribute = 01 meaning it is ISO or r2,EP_ISO
ret
```

■ Fix Status

No silicon revision planned, use workaround.

14. Missing Endpoint Interrupts in USB Peripheral Mode

■ Problem Definition

USB peripheral designs may miss endpoint interrupts when receiving Endpoint 0 (EP0) Control transfer requests mixed with other endpoint transfer type transactions.

■ Parameters Affected

All USB peripheral mode endpoint communication may potentially be affected.

■ Trigger Condition(S)

An endpoint interrupt may be missed when a non-EP0 transaction completes (with ACK) during an EP0 Control transfer or within ~200 μ s before or after the EP0 Control transfer. Other processor activity and interrupts may influence the likelihood of this failure occurring.

■ Scope of Impact

This errata item applies to USB peripheral mode only. All USB peripheral designs that mix Standard, Vendor, or Class EP0 requests with other transfer types are potential candidates for this issue. If this problem occurs and an endpoint interrupt is missed, the endpoint will likely not be rearmed and therefore endpoint communication will be halted and the host system may reset the device.

■ Workaround

A. The PC Application and/or driver must be developed to ensure at least ~200 μ s of idle time is given before and after any EP0 transfers. The driver must ensure that no other transfer type transactions occur during the EP0 transfer or during this idle time before and after the EP0 transfer. Therefore, the driver cannot submit asynchronous Control transfers. The driver must submit Control transfer requests synchronously with other transfer requests. In addition, the driver must be aware of any interrupt endpoint scheduling (which is under control of the host controller driver) when submitting Control transfers. This generally means that a vendor-specific driver is required.

B. USB endpoint communication stress testing of any USB peripheral designs that mix EP0 Control transfers with other transfer types is recommended.

■ Fix Status

No silicon revision planned, use workaround.

Document History Page

Document Title: CY7C67300, EZ-Host™ Programmable Embedded USB Host and Peripheral Controller with Automotive AEC Grade Support Document Number: 38-08015				
Revision	ECN	Orig. of Change	Submission Date	Description of Change
**	111872	MUL	03/22/02	New Data Sheet
*A	116989	MUL	08/23/02	Preliminary Data Sheet
*B	125262	MUL	04/10/03	Added Memory Map Section and Ordering Information Section Moved Functional Register Map Tables into Register section General Clean-up
*C	126210	MUL	05/23/03	Added Interface Description Section and Power Savings and Reset Section Added Char Data General Clean-up
*D	127335	KKV	05/29/03	Corrected font to enable correct symbol display
*E	129395	MUL	10/01/03	Final Data Sheet Changed Memory Map Section and added CLKSEL to Pin Description Added USB OTG Logo General Clean-up
*F	443992	VCS	See ECN	Title changed indicating AEC Grade Added information for AEC qualified including part number Fixed misc. errors including: Table 4-1: UART does not have alternate location Section 4.3.4 had incorrect register address Table 4-10 had incorrect pin definitions Section 4.16.2 changed GPIO[31:20] to GPIO[31:30] Corrected Table 7-6 and 7-14
*G	566465	KKVTMP	See ECN	Added the lead free information on the Ordering Information Section. Implemented the new template with no numbers on the headings.
*H	1063560	ARI	See ECN	Changed Ordering Information table to reflect Automotive Qualification and to meet the MPN Part Number changes reflected in ECN 884880. Changed the EZ-Host Pin Diagram figure to reflect the pin changes. Edited.
*I	2514867	PYRS	See ECN	To publish in Web
*J	2544823	BHA/AESA	07/28/08	Updated template. Corrected A18 and A17 pin assignments in Tables 6 and 131.
*K	3302644	NMMA	07/05/11	Added CY4640 Reference Design entry in Ordering Information Table. Included table of contents. Added ordering code definitions, acronyms, and units of measure. Updated package diagram from *C to *E
*L	3997633	PRJI	05/11/2013	Updated Package Diagram : spec 51-85048 – Changed revision from *E to *G. Added Errata .

Document History Page (Continued)

Document Title: CY7C67300, EZ-Host™ Programmable Embedded USB Host and Peripheral Controller with Automotive AEC Grade Support Document Number: 38-08015				
Revision	ECN	Orig. of Change	Submission Date	Description of Change
*M	4080334	PRJI	07/29/2013	<p>Added Errata footnotes (Note 3, 4, 9, 10, 11, 12, 13, 14, 15).</p> <p>Updated Interface Descriptions: Updated UART Interface [3]: Added Note 3 and referred the same note in the heading. Updated I2C EEPROM Interface [4]: Added Note 4 and referred the same note in the heading.</p> <p>Updated Registers: Updated Processor Control Registers: Updated Interrupt Enable Register [0xC00E] [R/W] [9]: Added Note 9 and referred the same note in the heading. Updated General USB Registers [10]: Added Note 10 and referred the same note in the heading. Updated USB Host Only Registers [11]: Added Note 11 and referred the same note in the heading. Updated USB Device Only Registers: Updated Device n Interrupt Enable Register [R/W]: Added Note 12 and referred the same note in "Register Description". Updated OTG Control Registers [13]: Added Note 13 and referred the same note in the heading. Updated IDE Registers: Added Note 14 and referred the same note in Table 82. Updated HPI Registers: Updated SIE1msg Register [W]: Added Note 15 and referred the same note in "SIE1msg Register 0x0144" and "SIE2msg Register 0x0148". Updated in new template.</p>
*N	5391844	RAJV	08/05/2016	<p>Document migrated to new template. Updated package diagram. Removed obsolete Development kit CY3663 from the ordering information.</p>
*O	5708844	AESATMP7	04/27/2017	Updated Logo and Copyright.
*P	6037062	RAJV	01/18/2018	Removed "CY4640" from the Ordering Information .

Sales, Solutions, and Legal Information

Worldwide Sales and Design Support

Cypress maintains a worldwide network of offices, solution centers, manufacturer's representatives, and distributors. To find the office closest to you, visit us at [Cypress Locations](#).

Products

Arm® Cortex® Microcontrollers	cypress.com/arm
Automotive	cypress.com/automotive
Clocks & Buffers	cypress.com/clocks
Interface	cypress.com/interface
Internet of Things	cypress.com/iot
Memory	cypress.com/memory
Microcontrollers	cypress.com/mcu
PSoC	cypress.com/psoc
Power Management ICs	cypress.com/pmic
Touch Sensing	cypress.com/touch
USB Controllers	cypress.com/usb
Wireless Connectivity	cypress.com/wireless

PSoC® Solutions

[PSoC 1](#) | [PSoC 3](#) | [PSoC 4](#) | [PSoC 5LP](#) | [PSoC 6](#)

Cypress Developer Community

[Forums](#) | [WICED IOT Forums](#) | [Projects](#) | [Video](#) | [Blogs](#) | [Training](#) | [Components](#)

Technical Support

cypress.com/support

© Cypress Semiconductor Corporation, 2002-2018. This document is the property of Cypress Semiconductor Corporation and its subsidiaries, including Spansion LLC ("Cypress"). This document, including any software or firmware included or referenced in this document ("Software"), is owned by Cypress under the intellectual property laws and treaties of the United States and other countries worldwide. Cypress reserves all rights under such laws and treaties and does not, except as specifically stated in this paragraph, grant any license under its patents, copyrights, trademarks, or other intellectual property rights. If the Software is not accompanied by a license agreement and you do not otherwise have a written agreement with Cypress governing the use of the Software, then Cypress hereby grants you a personal, non-exclusive, nontransferable license (without the right to sublicense) (1) under its copyright rights in the Software (a) for Software provided in source code form, to modify and reproduce the Software solely for use with Cypress hardware products, only internally within your organization, and (b) to distribute the Software in binary code form externally to end users (either directly or indirectly through resellers and distributors), solely for use on Cypress hardware product units, and (2) under those claims of Cypress's patents that are infringed by the Software (as provided by Cypress, unmodified) to make, use, distribute, and import the Software solely for use with Cypress hardware products. Any other use, reproduction, modification, translation, or compilation of the Software is prohibited.

TO THE EXTENT PERMITTED BY APPLICABLE LAW, CYPRESS MAKES NO WARRANTY OF ANY KIND, EXPRESS OR IMPLIED, WITH REGARD TO THIS DOCUMENT OR ANY SOFTWARE OR ACCOMPANYING HARDWARE, INCLUDING, BUT NOT LIMITED TO, THE IMPLIED WARRANTIES OF MERCHANTABILITY AND FITNESS FOR A PARTICULAR PURPOSE. No computing device can be absolutely secure. Therefore, despite security measures implemented in Cypress hardware or software products, Cypress does not assume any liability arising out of any security breach, such as unauthorized access to or use of a Cypress product. In addition, the products described in these materials may contain design defects or errors known as errata which may cause the product to deviate from published specifications. To the extent permitted by applicable law, Cypress reserves the right to make changes to this document without further notice. Cypress does not assume any liability arising out of the application or use of any product or circuit described in this document. Any information provided in this document, including any sample design information or programming code, is provided only for reference purposes. It is the responsibility of the user of this document to properly design, program, and test the functionality and safety of any application made of this information and any resulting product. Cypress products are not designed, intended, or authorized for use as critical components in systems designed or intended for the operation of weapons, weapons systems, nuclear installations, life-support devices or systems, other medical devices or systems (including resuscitation equipment and surgical implants), pollution control or hazardous substances management, or other uses where the failure of the device or system could cause personal injury, death, or property damage ("Unintended Uses"). A critical component is any component of a device or system whose failure to perform can be reasonably expected to cause the failure of the device or system, or to affect its safety or effectiveness. Cypress is not liable, in whole or in part, and you shall and hereby do release Cypress from any claim, damage, or other liability arising from or related to all Unintended Uses of Cypress products. You shall indemnify and hold Cypress harmless from and against all claims, costs, damages, and other liabilities, including claims for personal injury or death, arising from or related to any Unintended Uses of Cypress products.

Cypress, the Cypress logo, Spansion, the Spansion logo, and combinations thereof, WICED, PSoC, CapSense, EZ-USB, F-RAM, and Traveo are trademarks or registered trademarks of Cypress in the United States and other countries. For a more complete list of Cypress trademarks, visit cypress.com. Other names and brands may be claimed as property of their respective owners.

Данный компонент на территории Российской Федерации

Вы можете приобрести в компании MosChip.

Для оперативного оформления запроса Вам необходимо перейти по данной ссылке:

<http://moschip.ru/get-element>

Вы можете разместить у нас заказ для любого Вашего проекта, будь то серийное производство или разработка единичного прибора.

В нашем ассортименте представлены ведущие мировые производители активных и пассивных электронных компонентов.

Нашей специализацией является поставка электронной компонентной базы двойного назначения, продукции таких производителей как XILINX, Intel (ex.ALTERA), Vicor, Microchip, Texas Instruments, Analog Devices, Mini-Circuits, Amphenol, Glenair.

Сотрудничество с глобальными дистрибьюторами электронных компонентов, предоставляет возможность заказывать и получать с международных складов практически любой перечень компонентов в оптимальные для Вас сроки.

На всех этапах разработки и производства наши партнеры могут получить квалифицированную поддержку опытных инженеров.

Система менеджмента качества компании отвечает требованиям в соответствии с ГОСТ Р ИСО 9001, ГОСТ РВ 0015-002 и ЭС РД 009

Офис по работе с юридическими лицами:

105318, г.Москва, ул.Щербаковская д.3, офис 1107, 1118, ДЦ «Щербаковский»

Телефон: +7 495 668-12-70 (многоканальный)

Факс: +7 495 668-12-70 (доб.304)

E-mail: info@moschip.ru

Skype отдела продаж:

moschip.ru

moschip.ru_4

moschip.ru_6

moschip.ru_9