

General Description

Micrel's MIC4827 is a high output voltage, DC to AC converter, designed for driving EL (Electroluminescent) lamps. The device operates from an input voltage range of 1.8V to 5.5V, making it suitable for 1-cell Li-Ion and 2- or 3-cell alkaline/NiCad/NiMH battery applications. The MIC4827 converts a low voltage DC input to a 180V_{PP} AC output signal that drives the EL lamp.

The MIC4827 is comprised of two stages: a boost stage, and an H-bridge, lamp driver, stage. The boost stage steps the input voltage up to +90V. The H-bridge stage then alternately switches the +90V output to each terminal of the EL lamp, thus creating a 180V_{PP} AC signal to drive the EL lamp and generate light.

The MIC4827 features separate oscillators for the boost and H-bridge stages. External resistors independently set the operating frequency of each stage. This flexibility allows the EL lamp circuit to be optimized for maximum efficiency and brightness.

The MIC4827 uses a single inductor and a minimum number of external components, making it ideal for portable, space-sensitive applications.

The MIC4827 is available in an 8-pin MSOP package with an ambient temperature range of -40°C to +85°C.

Features

- 1.8V to 5.5V DC input voltage
- 180V_{PP} regulated AC output waveform
- Independently adjustable EL lamp frequency
- Independently adjustable boost converter frequency
- 0.1µA shutdown current

Applications

- LCD panel backlight
- Cellular phones
- PDAs
- Pager
- Calculators
- Remote controls
- Portable phones

Typical Application

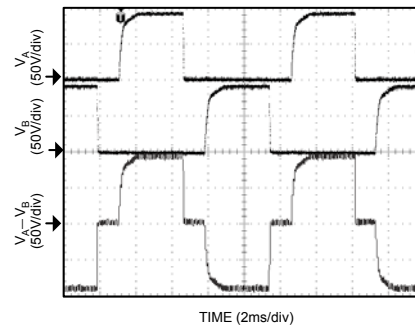
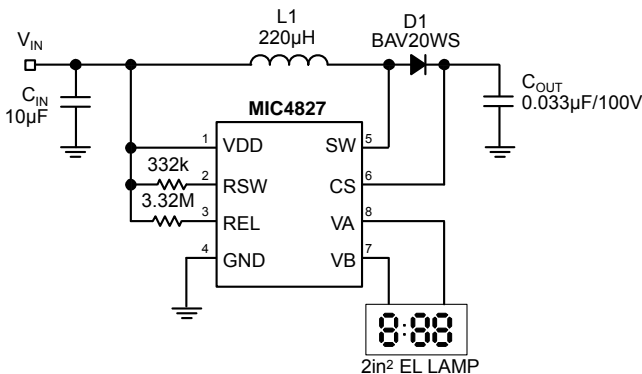

High Voltage EL Driver

Ordering Information

| Part Number | | Ambient Temp. Range | Package |
|-------------|------------|---------------------|------------|
| Standard | Pb-Free | | |
| MIC4827BMM | MIC4827YMM | -40° to +85°C | 8-Pin MSOP |

Pin Configuration

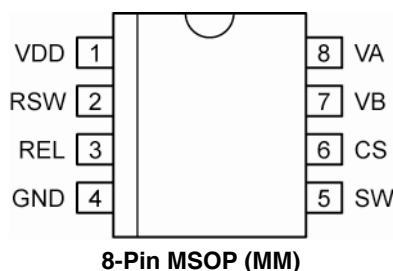

Pin Description

| Pin Number | Pin Name | Pin Function |
|------------|----------|--|
| 1 | VDD | Supply (Input): 1.8V to 5.5V. |
| 2 | RSW | Switcher Resistor (External Component): Set switch frequency of the internal power MOSFET by connecting an external resistor to VDD. Connecting the external resistor to GND disables the switch oscillator and shuts down the device. |
| 3 | REL | EL Resistor (External Component): Set EL frequency of the internal H-bridge driver by connecting an external resistor to VDD. Connecting the external resistor to GND disables the EL oscillator. |
| 4 | GND | Ground Return. |
| 5 | SW | Switch Node (Input): Internal high-voltage power MOSFET drain. |
| 6 | CS | Regulated Boost Output (External Component): Connect the output capacitor of the boost regulator and connect to the cathode of the diode. |
| 7 | VB | EL Output: Connect to one end of the EL lamp. Polarity is not important. |
| 8 | VA | EL Output: Connect to the other end of the EL lamp. Polarity is not important. |

Absolute Maximum Ratings⁽¹⁾

| | |
|---|-----------------------------------|
| Supply Voltage (V_{DD}) |-0.5 to 6V |
| Output Voltage (V_{CS}) |-0.5 to 100V |
| Freq. Control Voltage (V_{RSW} , V_{REL}) | -0.5 to ($V_{DD} + 0.3V$) |
| Power Dissipation @ $T_A = 85^\circ C$ |200mW |
| Storage Temperature (T_s) |-65°C to +150°C |
| EDS Rating ⁽³⁾ | |

Operating Ratings⁽²⁾

| | |
|---|----------------------|
| Supply Voltage (V_{DD}) | +1.8V to +5.5V |
| Lamp Drive Frequency (f_{EL}) | 60Hz to 1000Hz |
| Switching Transistor Frequency (f_{SW}) |8KHz to 200KHz |
| Ambient Temperature (T_A) | -40°C to +85°C |
| Junction Thermal Resistance | |
| PDIP (θ_{JA}) |206°C/W |

Electrical Characteristics⁽⁴⁾

$V_{IN} = V_{DD} = 3.0V$; $R_{SW} = 560K\Omega$; $R_{EL} = 1.0M\Omega$; $T_A = 25^\circ C$, **bold** values indicate $-40^\circ C \leq T_A \leq +85^\circ C$, unless noted.

| Symbol | Parameter | Condition | Min | Typ | Max | Units |
|--------------|--|---|----------------|------|-------------------|--------------------|
| $R_{DS(ON)}$ | On-resistance of switching transistor | $I_{SW} = 100mA$, $V_{CS} = 85V$ | | 3.8 | 7.0 | Ω |
| V_{CS} | Output voltage regulation | $V_{DD} = 1.8V$ to $5.5V$ | 85 | 90 | 95 | V |
| | | | 83 | | 97 | V |
| $V_A - V_B$ | Output peak-to-peak voltage | $V_{DD} = 1.8V$ to $5.5V$ | 170 | 180 | 190 | V |
| | | | 166 | | 194 | V |
| V_{EN-L} | Input low voltage (turn-off) | $V_{DD} = 1.8V$ to $5.5V$ | | | 0.5 | V |
| V_{EN-H} | Input high voltage (turn-on) | $V_{DD} = 1.8V$ to $5.5V$ | $V_{DD} - 0.5$ | | | V |
| I_{SD} | Shutdown current, Note 5 | $R_{SW} = LOW$; $R_{EL} = LOW$; $V_{DD} = 5.5V$ | | 0.01 | 0.1 0.5 | μA μA |
| I_{VDD} | Input supply current | $R_{SW} = HIGH$; $R_{EL} = HIGH$; $V_{CS} = 85V$; V_A, V_B OPEN | | 21 | 75 | μA |
| I_{CS} | Boosted supply current | $R_{SW} = HIGH$; $R_{EL} = HIGH$; $V_{CS} = 85V$; V_A, V_B OPEN | | 200 | 400 | μA |
| I_{IN} | Input current including inductor current | $V_{IN} = V_{DD} = 1.8V$ (See Test Circuit) | | 28 | | mA |
| f_{EL} | $V_A - V_B$ output drive frequency | | 285 | 360 | 435 | Hz |
| f_{SW} | Switching transistor frequency | | 53 | 66 | 79 | kHz |
| D | Switching transistor duty cycle | | | 90 | | % |

Notes:

1. Exceeding the absolute maximum rating may damage the device.
2. The device is not guaranteed to function outside its operating rating.
3. Devices are ESD sensitive. Handling precautions recommended.
4. Specification for packaged product only.
5. Shutdown current is defined as the sum of current going into pin 1, 5, and 6 when the device is disabled.

Test Circuit

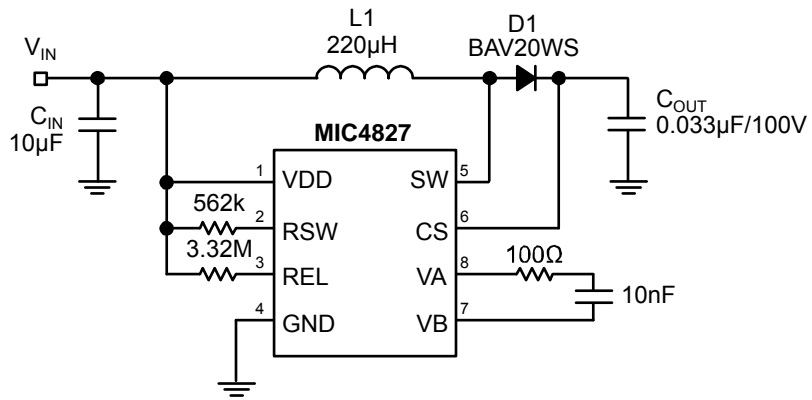

Typical Characteristics

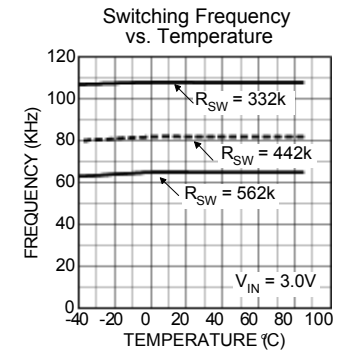
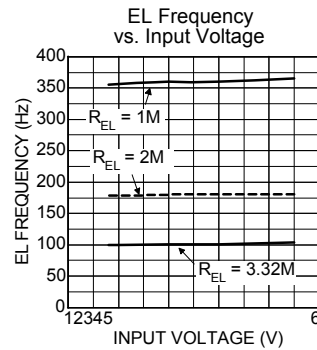
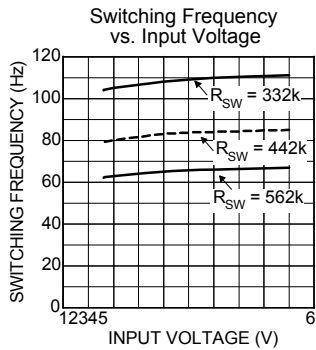
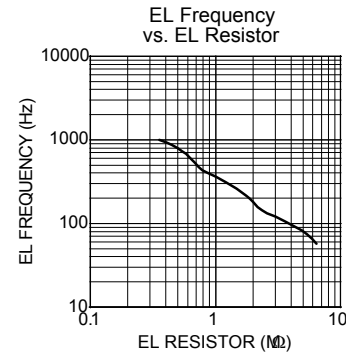
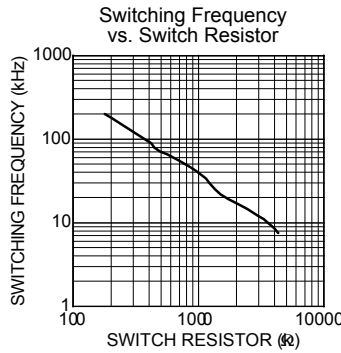
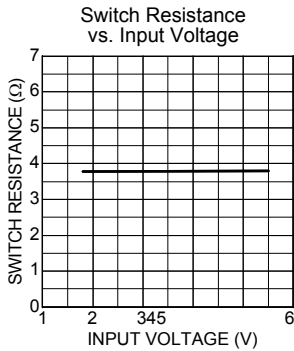
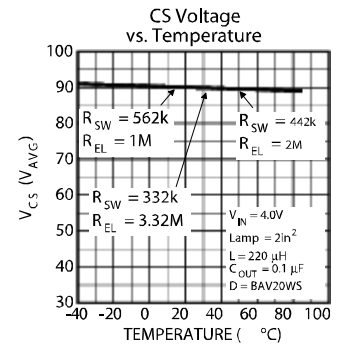
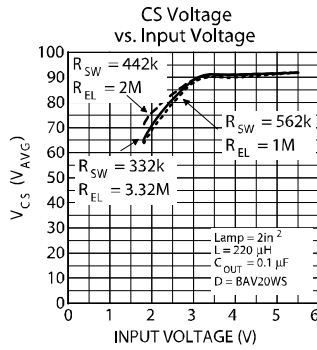
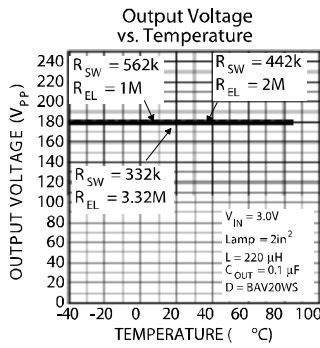
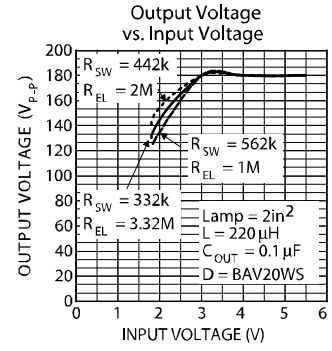
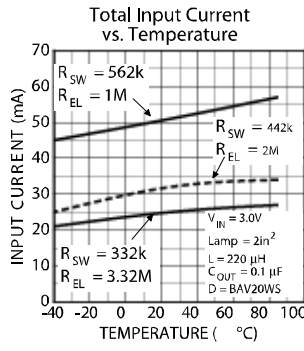
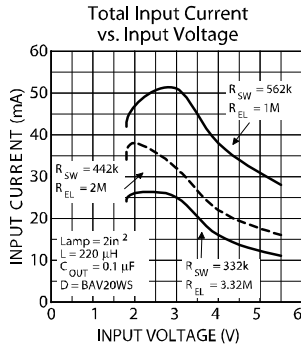

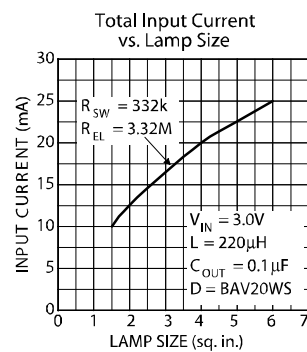
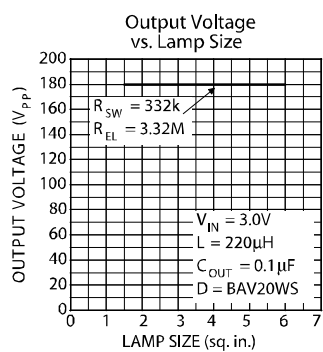
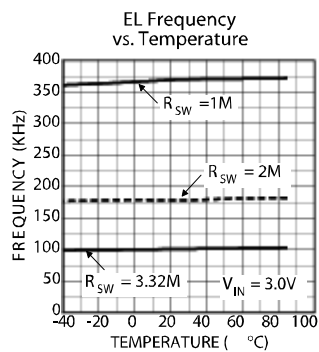

Block Diagram

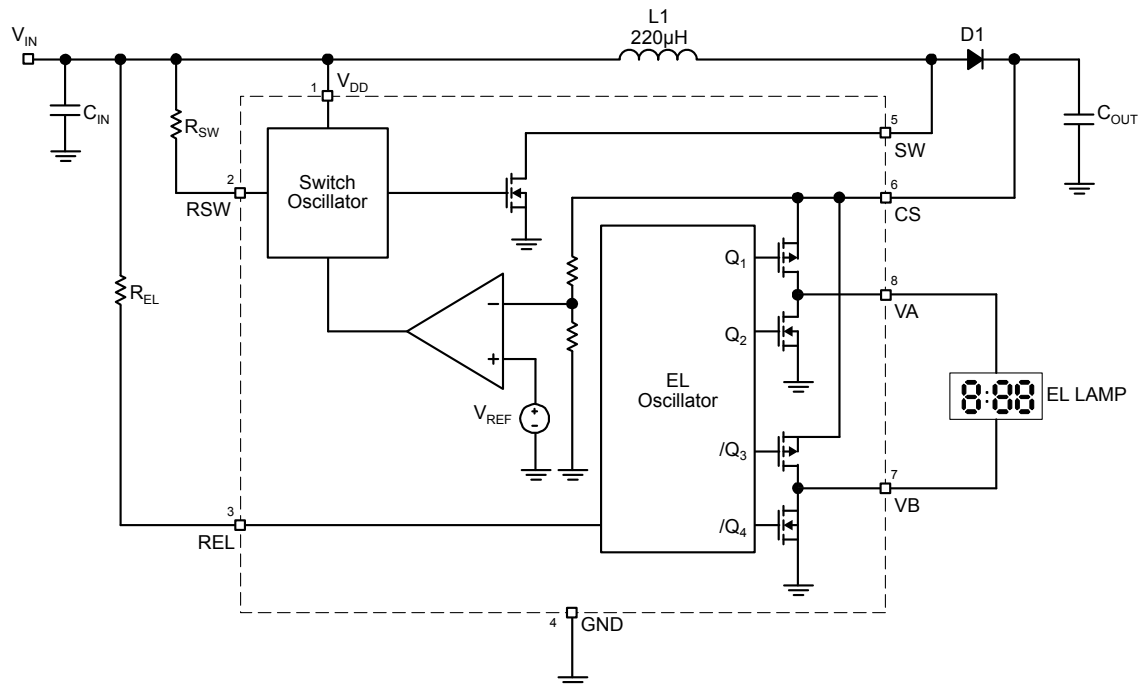

Figure 1. MIC4827 Block Diagram

Functional Description

Overview

The MIC4827 is a high-voltage EL driver with an AC output voltage of 180V peak-to-peak capable of driving EL lamps up to 6in². Input supply current for the MIC4827 is typically 21µA with a typical shutdown current of 10nA. The high voltage EL driver has two internal oscillators to control the switching MOSFET and the H-bridge driver. Both of the internal oscillators' frequencies can be individually programmed through the external resistors to maximize the efficiency and the brightness of the lamps.

Regulation

Referring to Figure 1, initially power is applied to V_{DD}. The internal feedback voltage is less than the reference voltage causing the internal comparator to go low which enables the switching MOSFET's oscillator. When the switching MOSFET turns on, current flows through the

inductor and into the switch. The switching MOSFET will typically turn on for 90% of the switching frequency. During the on-time, energy is stored in the inductor. When the switching MOSFET turns off, current flowing into the inductor forces the voltage across the inductor to reverse polarity. The voltage across the inductor rises until the external diode conducts and clamps the voltage at $V_{OUT} + V_{D1}$. The energy in the inductor is then discharged into the C_{OUT} capacitor. The internal comparator continues to turn the switching MOSFET on and off until the internal feedback voltage is above the reference voltage. Once the internal feedback voltage is above the reference voltage, the internal comparator turns off the switching MOSFET's oscillator.

When the EL oscillator is enabled, V_A and V_B switch in opposite states to achieve a 180V peak-to-peak AC output signal. The external resistor that connects to the REL pin determines the EL frequency.

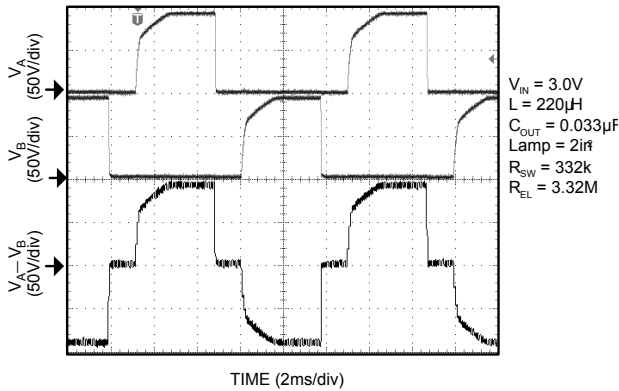

Figure 2. 108Hz Typical Output Waveform

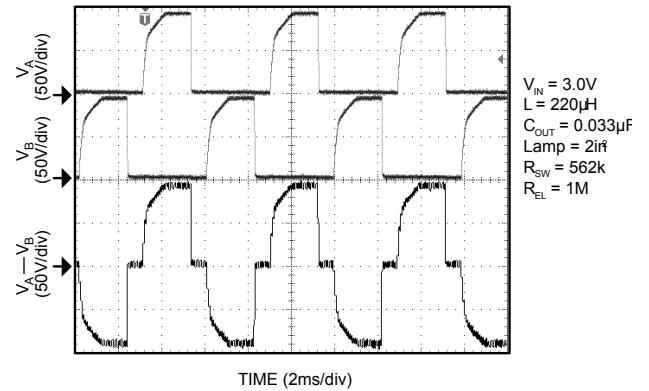

Figure 3. 180Hz Output Waveform

Switching Frequency

The switching frequency of the converter is controlled via an external resistor between R_{SW} pin and V_{DD} pin of the device. The switching frequency increases as the resistor value decreases. For resistor value selections, see the “Typical Characteristics: Switching Frequency vs. Switch Resistor” or use the equation below. The switching frequency range is 8kHz to 200kHz, with an accuracy of ±20%.

$$f_{SW} \text{ (kHz)} = \frac{36}{R_{SW} \text{ (M}\Omega)}$$

EL Frequency

The EL lamp frequency is controlled via an external resistor connected between R_{EL} pin and V_{DD} pin of the device. The lamp frequency increases the resistor value decreases. For resistor value selections, see the “Typical Characteristics: EL Frequency vs. EL Resistor” or use the equation below. The switching frequency range is 60Hz to 1000Hz, with an accuracy of ±20%.

$$f_{EL} \text{ (Hz)} = \frac{360}{R_{EL} \text{ (M}\Omega)}$$

In general, as the EL lamp frequency increases, the amount of current drawn from the battery will increase. The color of the EL lamp and the intensity are dependent upon its frequency.

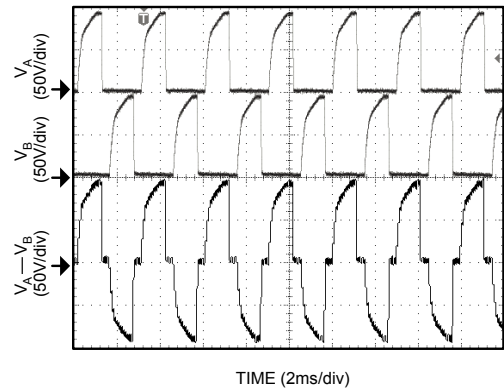

Figure 4. 360Hz Output Waveform

Enable Function

The enable function of the MIC4827 is implemented by switching the R_{SW} and R_{EL} resistor between ground and V_{DD}. When R_{SW} and R_{EL} are connected to ground, the switch and the EL oscillators are disabled; therefore the EL driver becomes disabled. When these resistors connect to V_{DD}, both the oscillators will function and the EL driver is enabled.

Application Information

Inductor

In general, smaller value inductors, which can handle more current, are more suitable to drive larger size lamps. As the inductor value decreases, the switching frequency (controlled by Rsw) should be increased to avoid saturation or the input voltage should be increased. Typically, inductor values ranging from 220µH to 560µH can be used. Murata offers the LQH3C series up to 560µH and LQH4C series up to 470µH, with low DC resistance. A 220µH Murata (LQH4C221K04) inductor is recommended for driving a lamp size of 3 square inches. It has a maximum DC resistance of 4.0Ω

Diode

The diode must have a high reverse voltage (150V), since the output voltage at the CS pin can reach up to 110V. A fast switching diode with lower forward voltage and higher reverse voltage (150V), such as BAV20WS, can be used to enhance efficiency.

Output Capacitor

Low ESR capacitors should be used at the regulated boost output (CS pin) of the MIC4827 to minimize the switching output ripple voltage. Selection of the capacitor value will depend upon the peak inductor current, inductor size, and the load. MuRata offers the GRM42-6 series with up to 0.047µF at 100V, with a X7R temperature coefficient in 1206 surface-mount package. Typically, values ranging from 0.01µF to 0.1µF at 100V can be used for the regulated boost output capacitor

Pre-designed Application Circuit

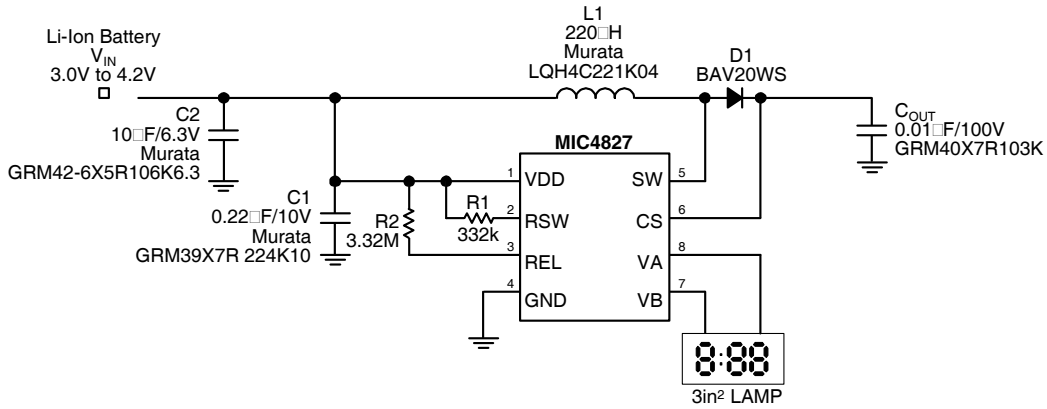

| V _{IN} | I _{IN} | V _A - V _B | F _{EL} | Lamp Size |
|-----------------|-----------------|---------------------------------|-----------------|------------------|
| 3.3V | 28mA | 180V _{PP} | 106Hz | 3in ² |

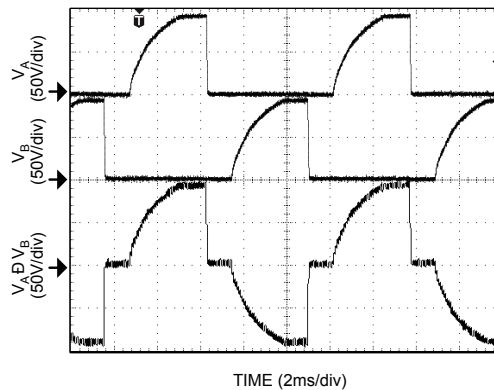
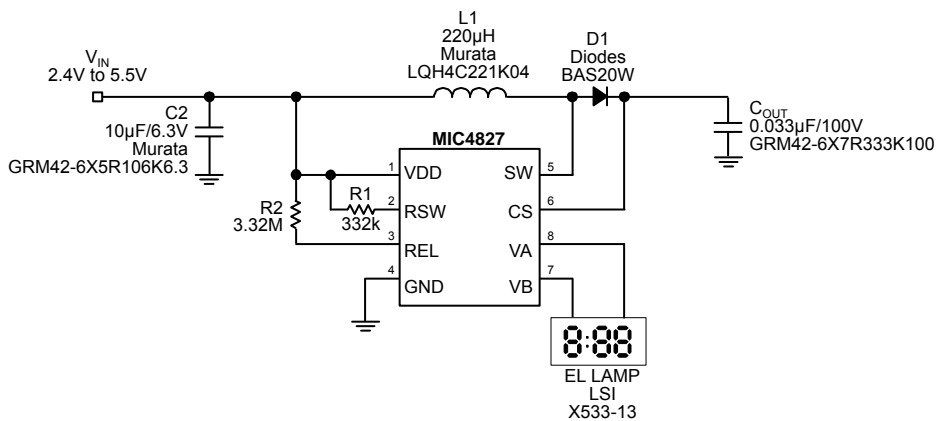

Figure 5. Typical 100Hz EL Driver for 3in² Lamp



| V_{IN} | I_{IN} | $V_A - V_B$ | F_{EL} | Lamp Size |
|----------|----------|--------------------|----------|------------------|
| 3.3V | 18mA | 180V _{PP} | 104Hz | 2in ² |

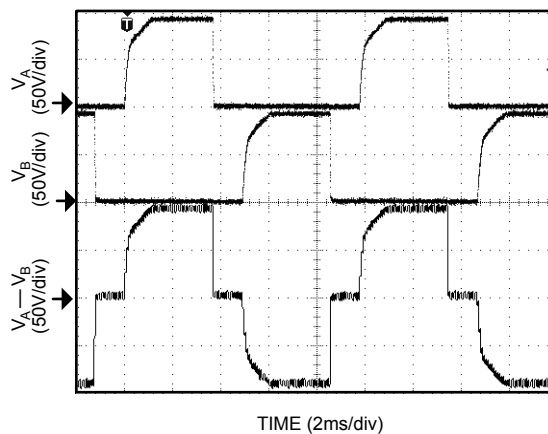
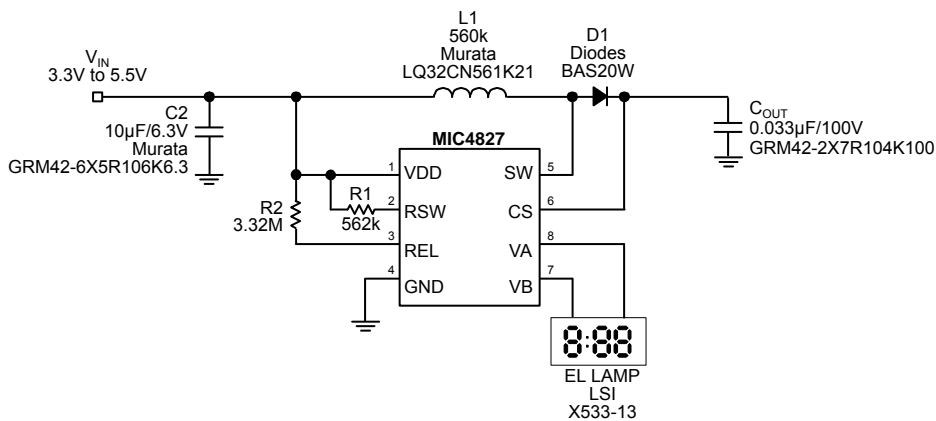

Figure 6. Typical EL Driver for 2in² Lamp with C_S = 0.033µF



| V_{IN} | I_{IN} | $V_A - V_B$ | F_{EL} | Lamp Size |
|----------|----------|--------------------|----------|------------------|
| 3.3V | 21mA | 180V _{PP} | 102Hz | 2in ² |

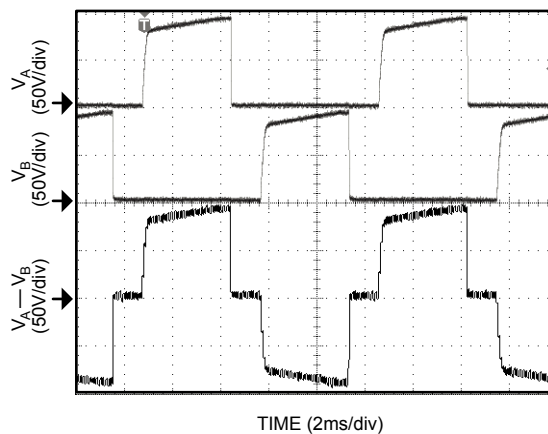
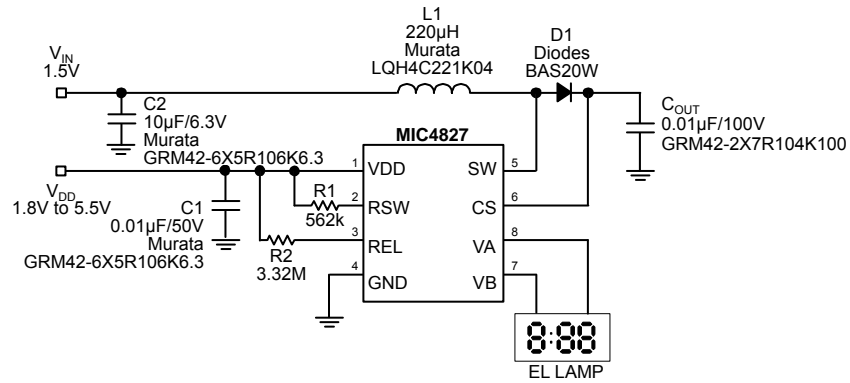

Figure 7. Typical EL Driver for 2in² Lamp with 560µH inductor



| V_{IN} | I_{IN} | V_{DD} | I_{DD} | $V_A - V_B$ | F_{EL} | Lamp Size |
|----------|----------|----------|----------|--------------------|----------|--------------------|
| 1.5V | 26mA | 3.0V | 32µA | 180V _{PP} | 104Hz | 1.6in ² |

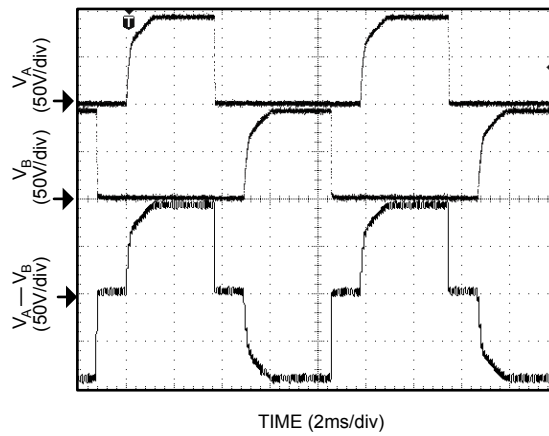
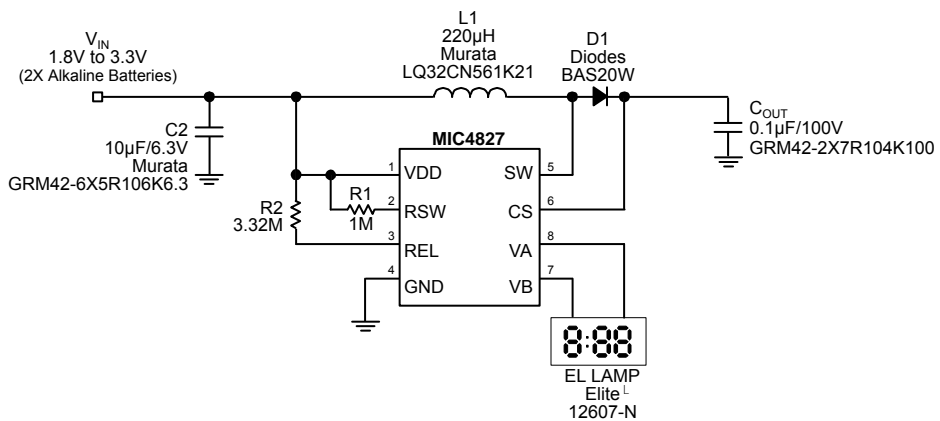

Figure 8. Typical Split Power Supplies Applications



| V_{IN} | I_{IN} | $V_A - V_B$ | F_{EL} | Lamp Size |
|----------|----------|--------------------|----------|--------------------|
| 3.0V | 31mA | 180V _{PP} | 104Hz | 5.3in ² |

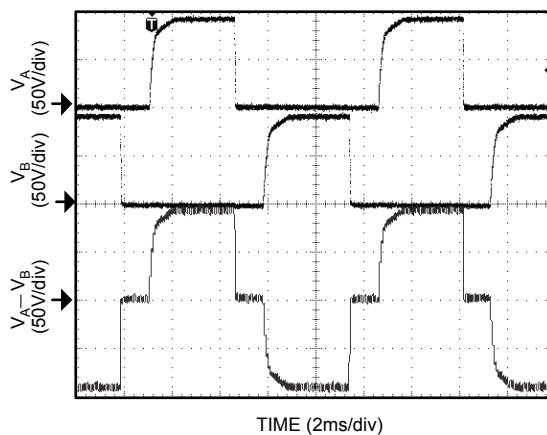
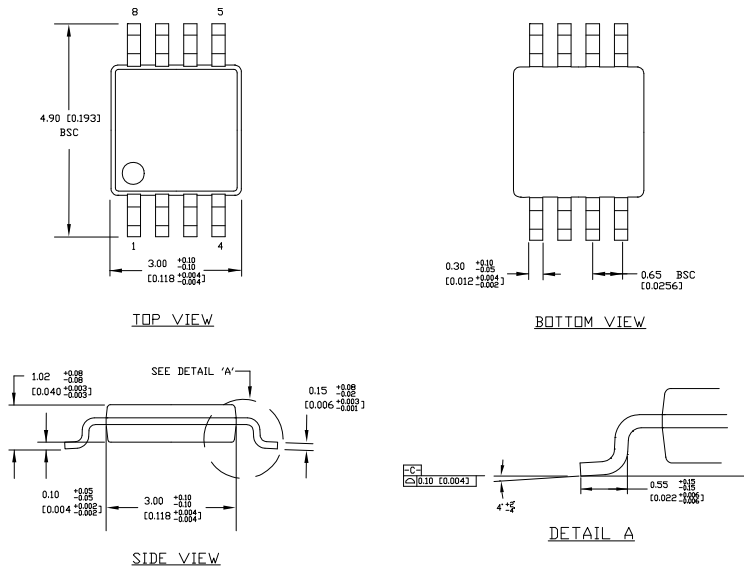

Figure 9. Typical EL Driver Remote Control Lamp (Blue Phosphor) Applications

Package Information



- NOTES:
1. DIMENSIONS ARE IN MM (INCHES).
 2. CONTROLLING DIMENSION: MM
 3. DIMENSION DOES NOT INCLUDE MOLD FLASH OR PROTRUSIONS, EITHER OF WHICH SHALL NOT EXCEED 0.20 [0.008] PER SIDE.

8-Pin MSOP (MM)

MICREL, INC. 2180 FORTUNE DRIVE SAN JOSE, CA 95131 USA
TEL +1 (408) 944-0800 FAX +1 (408) 474-1000 WEB <http://www.micrel.com>

The information furnished by Micrel in this data sheet is believed to be accurate and reliable. However, no responsibility is assumed by Micrel for its use. Micrel reserves the right to change circuitry and specifications at any time without notification to the customer.

Micrel Products are not designed or authorized for use as components in life support appliances, devices or systems where malfunction of a product can reasonably be expected to result in personal injury. Life support devices or systems are devices or systems that (a) are intended for surgical implant into the body or (b) support or sustain life, and whose failure to perform can be reasonably expected to result in a significant injury to the user. A Purchaser's use or sale of Micrel Products for use in life support appliances, devices or systems is a Purchaser's own risk and Purchaser agrees to fully indemnify Micrel for any damages resulting from such use or sale.

© 2001 Micrel, Incorporated.

Данный компонент на территории Российской Федерации

Вы можете приобрести в компании MosChip.

Для оперативного оформления запроса Вам необходимо перейти по данной ссылке:

<http://moschip.ru/get-element>

Вы можете разместить у нас заказ для любого Вашего проекта, будь то серийное производство или разработка единичного прибора.

В нашем ассортименте представлены ведущие мировые производители активных и пассивных электронных компонентов.

Нашей специализацией является поставка электронной компонентной базы двойного назначения, продукции таких производителей как XILINX, Intel (ex.ALTERA), Vicor, Microchip, Texas Instruments, Analog Devices, Mini-Circuits, Amphenol, Glenair.

Сотрудничество с глобальными дистрибьюторами электронных компонентов, предоставляет возможность заказывать и получать с международных складов практически любой перечень компонентов в оптимальные для Вас сроки.

На всех этапах разработки и производства наши партнеры могут получить квалифицированную поддержку опытных инженеров.

Система менеджмента качества компании отвечает требованиям в соответствии с ГОСТ Р ИСО 9001, ГОСТ РВ 0015-002 и ЭС РД 009

Офис по работе с юридическими лицами:

105318, г.Москва, ул.Щербаковская д.3, офис 1107, 1118, ДЦ «Щербаковский»

Телефон: +7 495 668-12-70 (многоканальный)

Факс: +7 495 668-12-70 (доб.304)

E-mail: info@moschip.ru

Skype отдела продаж:

moschip.ru

moschip.ru_4

moschip.ru_6

moschip.ru_9