

LONG RANGE RFID TAG IDEAL FOR METAL SURFACES



25.0 x 9.0 x 3.7 mm

 RoHS/RoHS II Compliant

 ESD Sensitive

MSL= 1

ART915X2509EP60-IC

FEATURES

- 1.8 meters read range on metal surfaces
- Wide -30°C to 85°C operating temperature range
- UHF band operation 902 to 928MHz
- Matched for lowest return loss at 915MHz
- Tag incorporates matched Alien H3 RFIC
- 25.0 x 9.0 x 3.7mm height ceramic tag
- ISO 18000-6C/EPC Class1 Gen2 compliant
- Peel & Stick easy installation
- Suitable for non-metal surfaces
- Robust, long life over wide temperature range

APPLICATIONS

- Asset tracking: vehicles, machinery, tools, steel containers, servers, etc.
- Product inventory management: metallic assemblies, chassis, doors, equipment, etc.
- Industrial Internet of Things (IIoT)
- Automatic Vehicle Identification (AVI)
- Wildlife Identification and Waste Management
- Long distance RFID /Non-Stop Access Control

STANDARD SPECIFICATIONS

PARAMETERS	MINIMUM	TYPICAL	MAXIMUM	UNITS	NOTE
Range of Receiving Frequency		902-928		MHz	
Frequency of Lowest Return Loss		915±5		MHz	(Based on 200 x 200 mm GND Plane)
IC Protocol	ISO 18000-6C/EPC Class1 Gen2				
Memory		96 EPC		Bits	
		512 User		Bits	
IC Type	Alien H3				
Reading Range		1.8		m	
Working Temperature	-30		+85	°C	
Storage Temperature	-40		+110	°C	
Frequency Temperature Coefficient		0±10		ppm/°C	
ESD (HBM)			2	KV	2KV Class 2 HBM

REVISED: 07/19/2018



5101 Hidden Creek Lane Spicewood TX 78669
 Phone: 512-371-6159 | Fax: 512-351-8858
 For terms and conditions of sale please visit:
www.abracon.com

ABRACON IS
 ISO9001-2015
 CERTIFIED

LONG RANGE RFID TAG IDEAL FOR METAL SURFACES



25.0 x 9.0 x 3.7 mm

RoHS/RoHS II Compliant

ESD Sensitive

MSL= 1

ART915X2509EP60-IC

MECHANICAL DIMENSIONS (ALL DIMENSIONS ARE IN mm)

Tolerances are ± 0.2 mm, unless otherwise specified*

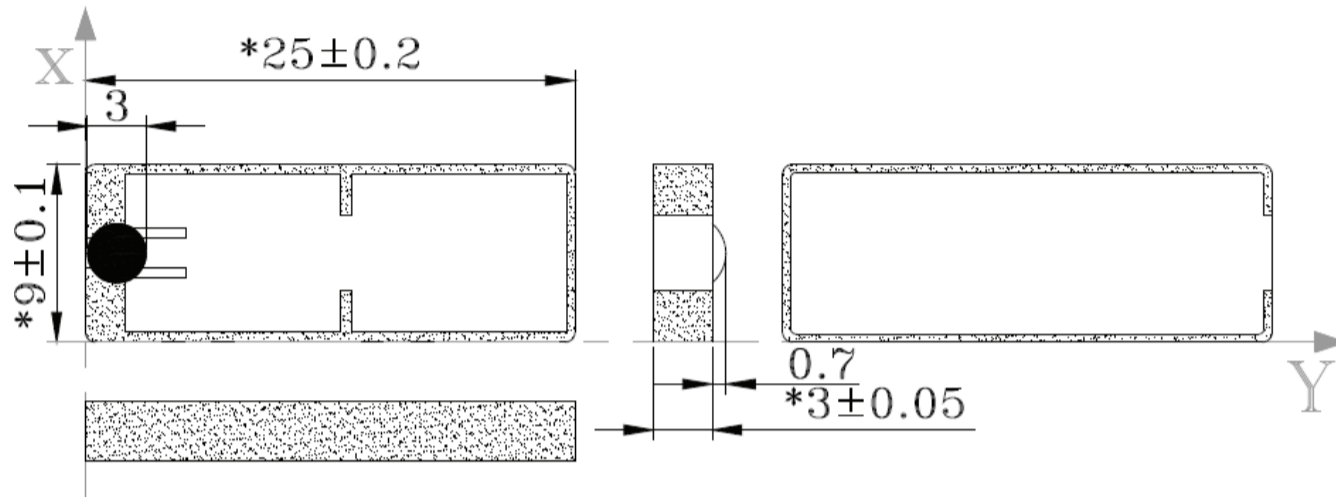

Mounting: Mounted with adhesive/tape (not included).

PACKAGING

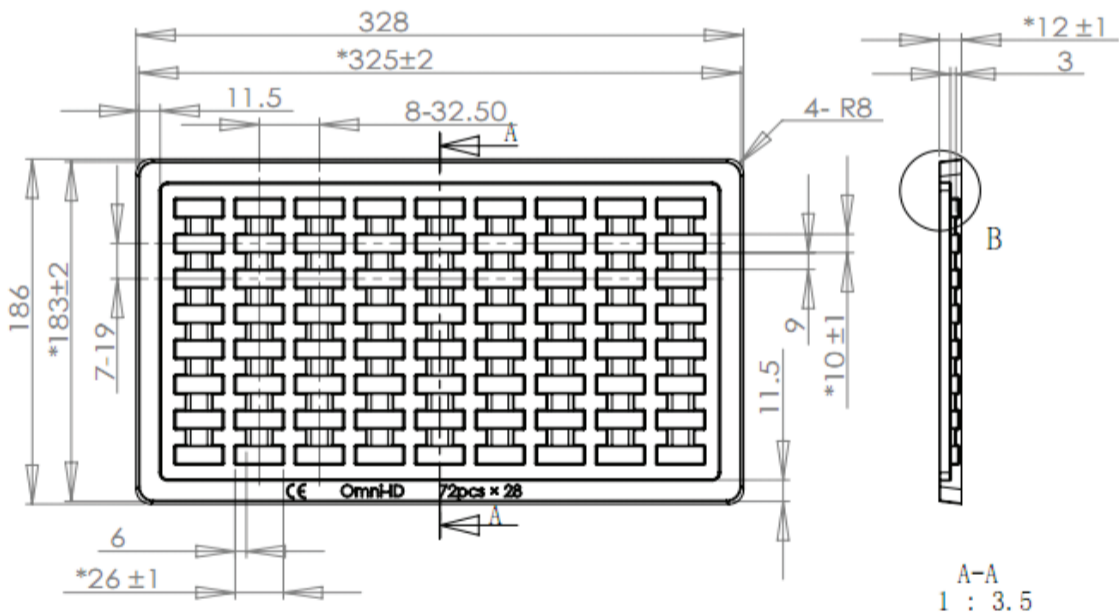

PACKAGE TYPE	QUANTITY
Tray	72 pcs/tray
Vacuum Bag	504pcs/ Vacuum Bag
MOQ	504pcs

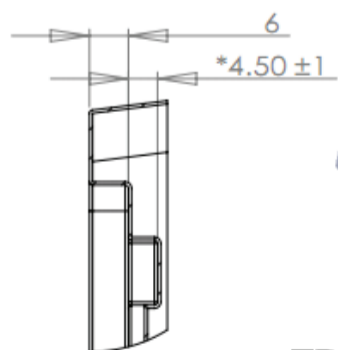

TRAY

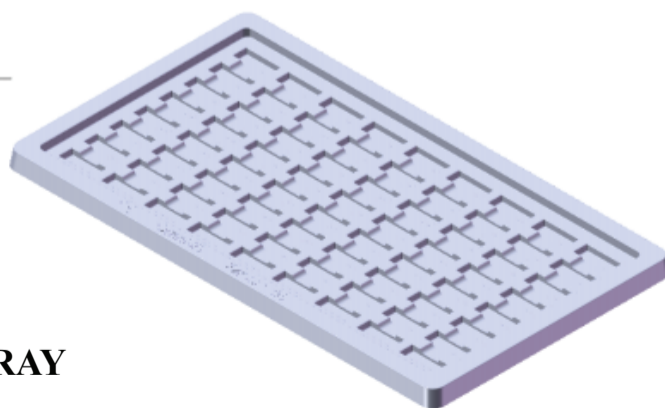

REVISED: 07/19/2018



5101 Hidden Creek Lane Spicewood TX 78669
 Phone: 512-371-6159 | Fax: 512-351-8858
 For terms and conditions of sale please visit:
www.abracon.com

ABRACON IS
 ISO9001-2015
 CERTIFIED

LONG RANGE RFID TAG IDEAL FOR METAL SURFACES



25.0 x 9.0 x 3.7 mm



RoHS/RoHS II Compliant



ESD Sensitive

MSL= 1

CAUTION

1. Do not apply excess mechanical stress to the component body or terminations. Do not attempt to re-form or bend the components as this will cause damage to the component.
2. Do not expose the component to open flame.
3. This specification applies to the functionality of the component as a single unit. For optimal performance, in-circuit validation is recommended.
4. Electrostatic sensitive device; observe standard precautions for handling.

NOTES

1. The parts are manufactured in accordance with this specification. If other conditions and specifications which are required for this specification, please contact ABRACON for more information.
2. ABRACON will supply the parts in accordance with this specification unless we receive a written request to modify prior to an order placement.
3. In no case shall ABRACON be liable for any product failure from in appropriate handling or operation of the item beyond the scope of this specification.
4. When changing your production process post-validation, please notify ABRACON immediately.
5. ABRACON's products are COTS – Commercial-Off-The-Shelf products; suitable for Commercial, Industrial and, where designated, Automotive Applications. ABRACON's products are not specifically designed for Military, Aviation, Aerospace, Life-dependant Medical applications or any application requiring high reliability where component failure could result in loss of life and/or property damage.
6. All specifications and Marking will be subject to change without notice.

REVISED: 07/19/2018



5101 Hidden Creek Lane Spicewood TX 78669
Phone: 512-371-6159 | Fax: 512-351-8858
For terms and conditions of sale please visit:
www.abracon.com

ABRACON IS
ISO9001-2015
CERTIFIED

Данный компонент на территории Российской Федерации

Вы можете приобрести в компании MosChip.

Для оперативного оформления запроса Вам необходимо перейти по данной ссылке:

<http://moschip.ru/get-element>

Вы можете разместить у нас заказ для любого Вашего проекта, будь то серийное производство или разработка единичного прибора.

В нашем ассортименте представлены ведущие мировые производители активных и пассивных электронных компонентов.

Нашей специализацией является поставка электронной компонентной базы двойного назначения, продукции таких производителей как XILINX, Intel (ex.ALTERA), Vicor, Microchip, Texas Instruments, Analog Devices, Mini-Circuits, Amphenol, Glenair.

Сотрудничество с глобальными дистрибьюторами электронных компонентов, предоставляет возможность заказывать и получать с международных складов практически любой перечень компонентов в оптимальные для Вас сроки.

На всех этапах разработки и производства наши партнеры могут получить квалифицированную поддержку опытных инженеров.

Система менеджмента качества компании отвечает требованиям в соответствии с ГОСТ Р ИСО 9001, ГОСТ РВ 0015-002 и ЭС РД 009

Офис по работе с юридическими лицами:

105318, г.Москва, ул.Щербаковская д.3, офис 1107, 1118, ДЦ «Щербаковский»

Телефон: +7 495 668-12-70 (многоканальный)

Факс: +7 495 668-12-70 (доб.304)

E-mail: info@moschip.ru

Skype отдела продаж:

moschip.ru

moschip.ru_4

moschip.ru_6

moschip.ru_9